

DECELERATION VALVES - IN-LINE MOUNTING

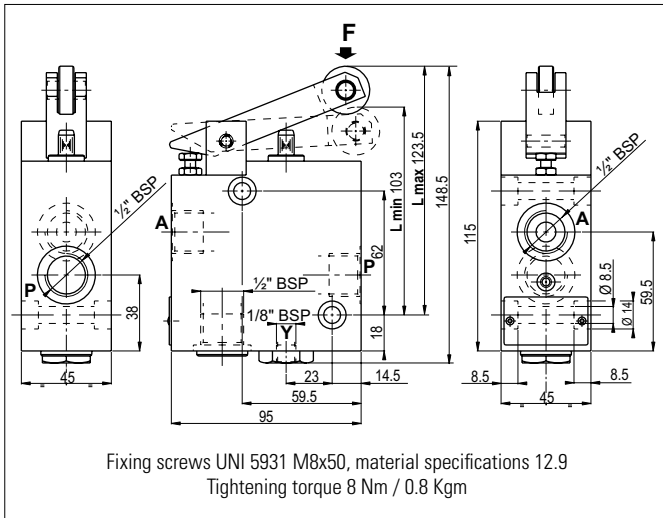

These valves are used as cam controlled unidirectional flow regulators. Normally mounted in line between actuator and directional valve for the displacement of carriages or slides, they enable cam controlled acceleration or deceleration of the moving mass.

A special internal check valve allows free flow the opposite direction. To ensure correct functioning, connect "Y" to draining line.

HYDRAULIC FEATURES

Max. working pressure	180 bar
Max. Flow	40 l/min
Max. Leakage	0.06 l/min
Cam travel	See diagram
Max. mechanical push force (F)	100 N
Hydraulic fluid	DIN 51524 Mineral oils
Fluid viscosity	10 ÷ 500 mm ² /s
Fluid temperature	-25°C ÷ 75°C
Ambient temperature	-25°C ÷ 60°C
Max. contamin. level class with filter	ISO 4406:1999 - class 19/17/14
Weight	2.8 kg

HYDRAULIC SYMBOL

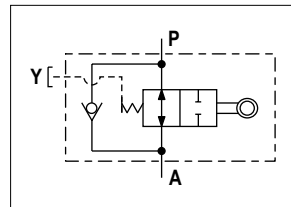

FLOW RATE / Lmin-Lmax

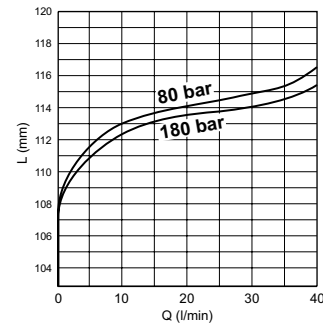

ORDERING CODE

