

LEVER OPERATED VALVES

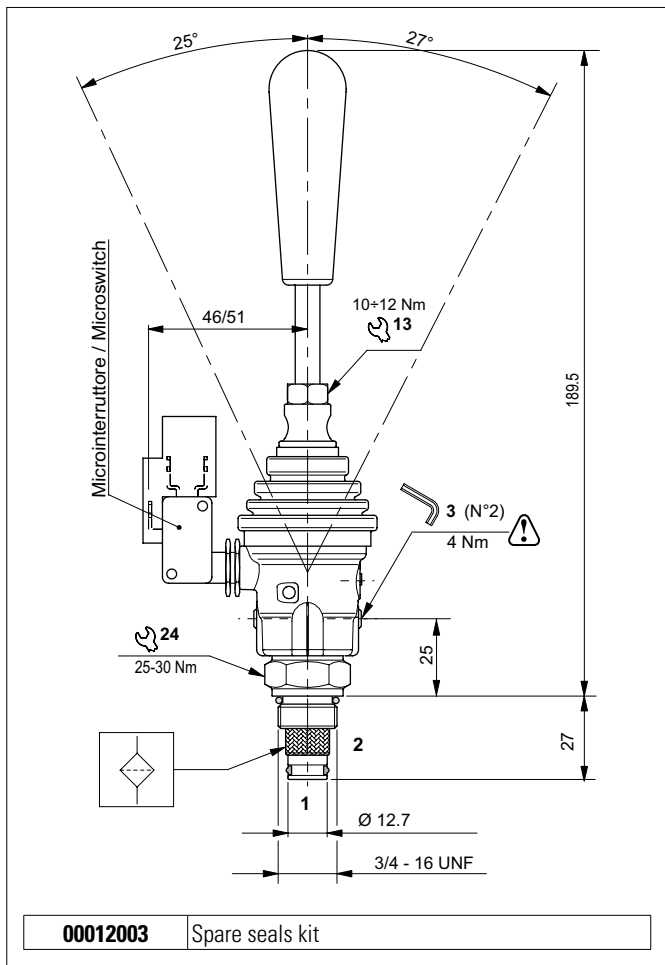

The direct acting, normally closed 2-way 2 position directional valve with manual control releases (load sensitive) pressure enabling fluid to flow through the valve from 2 to 1.

Tapered poppet is in tempered and ground steel.

Micro switch controlling a motor-driven pump relay supplied on request.

The lever body is in die-cast aluminium and the valve body in galvanised steel.

HYDRAULIC FEATURES

Max. working pressure	300 bar
Max. Flow	25 l/min
Max. Leakage (0 ÷ 5 drops/min)	0 ÷ 0.25 cm ³ /min
Working Temperature	-25°C ÷ 60°C
Hydraulic fluid	DIN 51524 Mineral oils
Fluid viscosity	10 ÷ 500 mm ² /s
Fluid temperature	-25°C ÷ 75°C
Max. contamin. level class with filter	ISO 4406:1999 - class 19/17/14
Tightening torque	25 ÷ 30 Nm
Weight	0.25 kg
Cavity (3/4 - 16 UNF)	CD018014 (See section 17)

Microswitch version

Mechanical life endurance at 250 Vac	10A (1E4) - 5A (5E4)
Protection degree with connector	IP40

PRESSURE DROPS (With valve completely open)

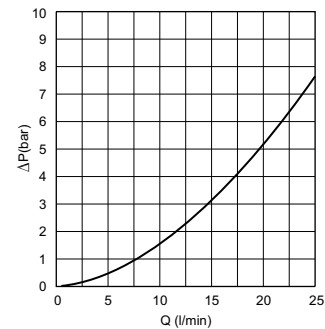

Fluid used: mineral based oil with viscosity 32 mm²/s at 40°C.

HYDRAULIC SYMBOLS

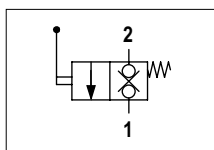

CMF04L
Without microswitch

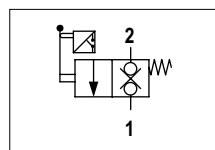

CMF04M
With microswitch

ORDERING CODE

