

SHUTTLE VALVES

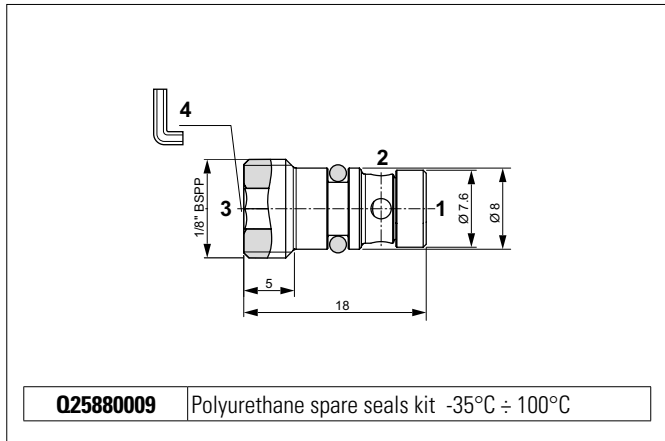

The shuttle type cartridge valves allow taking of the highest pressure signal to the external port via displacement of tempered and ground steel ball. There are usually employed to signal the actuator load to a load sensing pump pressure compensator. External steel body.

HYDRAULIC FEATURES

Max. working pressure	400 bar
Max. Flow	8 l/min
Hydraulic fluid	DIN 51524 Mineral oils
Fluid viscosity	10 ÷ 500 mm ² /s
Fluid temperature	-25°C ÷ 75°C
Ambient temperature	-25°C ÷ 60°C
Max. contamin. level class with filter	ISO 4406:1999 - class 19/17/14
Weight	0.006 kg
Tightening torque	16 ÷ 18 Nm
Cavity (G 1/8)	CG001002 (See section 17)

4

HYDRAULIC SYMBOL

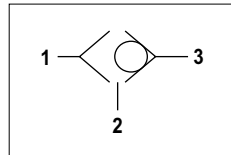

PRESSURE DROPS

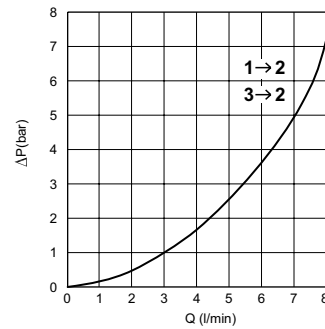

Fluid used: mineral based oil with viscosity 46 mm²/s at 40°C.

ORDERING CODE

