

UNIDIRECTIONAL AND BIDIRECTIONAL FLOW CONTROL VALVES - IN-LINE MOUNTING

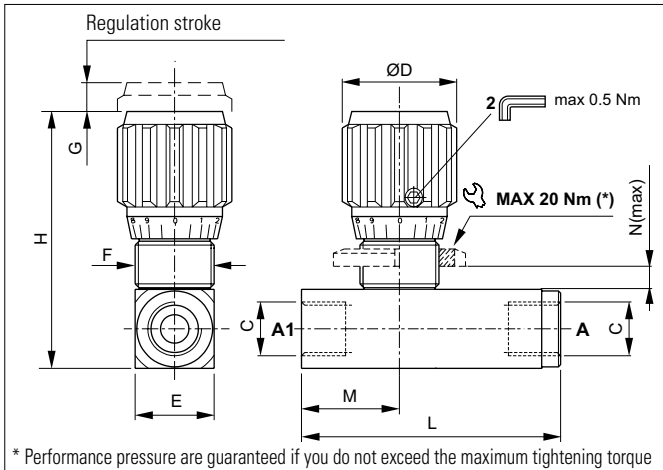

Flow control valve using non compensated throttling. The flow is reduced in only one direction (A to A1) for STU valves and in both directions for STB valves, turning the wheel with locking screw right or left. Guarantees excellent mechanical seal with negligible leakage. It has a galvanised steel body. The check valve tapered poppet is in tempered and ground steel.

HYDRAULIC FEATURES

Hydraulic fluid	DIN 51524 Mineral oils
Fluid viscosity	10 ÷ 500 mm ² /s
Fluid temperature	-25°C ÷ 75°C
Ambient temperature	-25°C ÷ 60°C
Max. contamin. level class with filter	ISO 4406:1999 - class 19/17/14

Code	C	Flow max (l/min)	Pressure max (bar)	L - STU (mm)	L - STB (mm)	H (mm)	D (mm)	E (mm)	F (mm)	G (mm)	M (mm)	N max (mm)	Weight - STU (kg)	Weight - STB (kg)	Weight screw (kg)
STU-STB 0400	1/4 BSP	20	400	73	54	68.5	31.5	20	M20x1	6	27	7	0.26	0.21	0.020
STU-STB 0600	3/8 BSP	30	400	82	62	80.5	35.5	25	M25x1.5	9.5	31	7	0.44	0.37	0.031
STU-STB 0800	1/2 BSP	50	350	98	73	93	41	30	M30x1.5	8	36.5	9	0.73	0.59	0.043
STU-STB 1200	3/4 BSP	85	320	112	84	110	47	40	M35x1.5	13	42	11	1.36	1.10	0.067
STU-STB 1600	1 BSP	150	300	142	100	121.5	47	45	M40x1.5	11.5	50	15	2	1.52	0.090

HYDRAULIC SYMBOLS

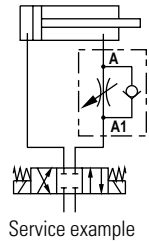
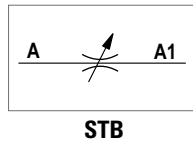
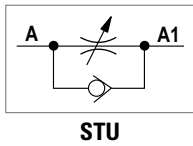

PRESSURE DROPS

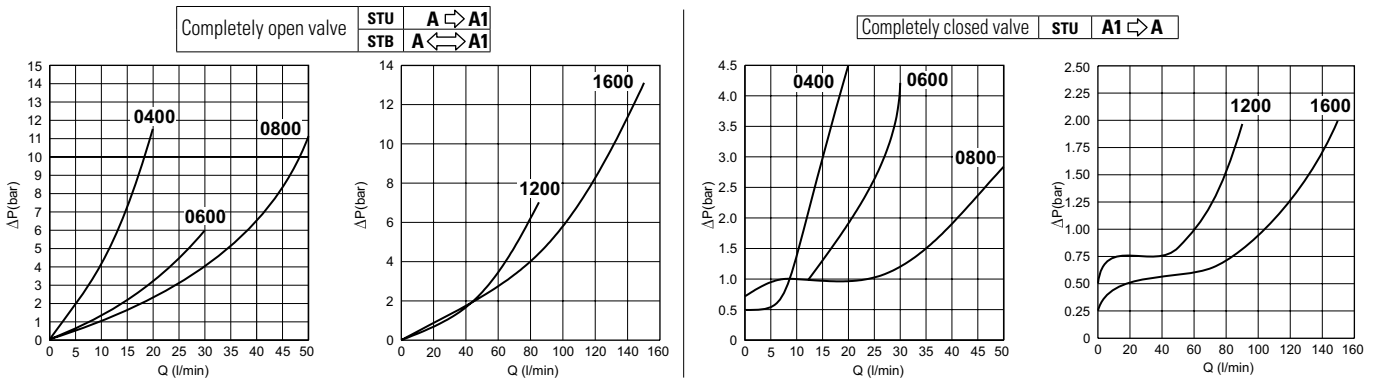

ORDERING CODE

