

DIRECTIONAL CONTROL BANKABLE VALVE WITH A09 COILS



Directional control bankable valve CDC3 with single or double solenoid.

- Centring achieved by means of calibrated length springs which immediately reposition the spool in the neutral position when the electrical signal is shut off.
- Different springs used for each spool to improve the valve performance.
- Emergency control.
- Body for parallel or series connections
- Threaded ports sizes G3/8" or 9/16"-18UNF (SAE 6), with or without LS line.
- Coils protection IP65
- Power supply DC or AC (with rectifier).
- Standard connectors DIN 43650 ISO 4400, AMP Junior, flying leads and Deutsch
- Maximum flow until 30 l/min.
- Cast iron zinc plated body.

1

Connector to be ordered separately, see page 103.

ORDERING CODE

CDC	Directional control bankable valve (with A09 coil)
3	Size
*	Body type (tab. 1)
E	Electrical operator
**	Spool (tab.2)
*	Mounting (tab.3)
*	Voltage (tab.4)
**	Variants (tab.5)
2	Serial No.

FEATURES

Max. pressure ports P/A/B/T	250 bar
Max. Flow	30 l/min
Max excitation frequency	3 Hz
Duty cycle	100% ED
Hydraulic fluid	DIN 51524 Mineral oils
Fluid viscosity	10 ÷ 500 mm ² /s
Fluid temperature	-25°C ÷ 75°C
Ambient temperature	-25°C ÷ 60°C
Max. contamination level (filter $\beta_{25} \geq 75$)	ISO 4406:1999: class 21/19/16 NAS 1638: class 10
Weight with one DC solenoid	1.25 kg
Weight with two DC solenoids	1.50 kg

Calibrated diaphragms on P line, see page 102.

ORDERING CODE

Tab.1 - Body type

Code	Body
A	Ports G3/8" parallel
B	Ports 9/16" - 18UNF parallel
D (1)	Ports G3/8" series
E (1)	Ports 9/16" - 18UNF series
G	Attachment style Parallel presetting for modular valves
H (1)	Attachment style Series presetting for modular valves
I	Ports 9/16" - 18UNF parallel - LS vers.
L	Ports G3/8" parallel - LS vers.
M	Attachment style, parallel-LS vers. Presetting for modular valves
S	Special connection B-P-A (see outlet module unit FUS3 pag .55)
U	Ports G3/8" parallel - P-T closed (not require the outlet module units)

Tab.2 - Standard spools

Two solenoids, spring centred "C" Mounting

Code		Covering	Transient position
01		+	
02		-	
03		+	
04 (2)		-	

One solenoid, side A "E" Mounting

Code		Covering	Transient position
01		+	
02		-	
03		+	
04 (2)		-	
15		-	
16		+	

One solenoid, side B "F" Mounting

Code		Covering	Transient position
01		+	
02		-	
03		+	
04 (2)		-	
15		-	
16		+	

Tab.3 - Mounting

Code	Symbol
C	
E	
F	
G (2)	
H (2)	

Tab.4 - Coils A09 voltage (7)

Code	Voltage	Max. winding temperature (Ambient temperature 25°C)	Rated power W	Resistance @ 20°C (Ohm) ±7%
L	12 Vdc	123 °C	27	5.3
M	24 Vdc	123 °C	27	21.3
N (3)	48 Vdc	123 °C	27	85.3
Z (4)	102 Vdc	123 °C	27	392
P (3)	110 Vdc	123 °C	27	448
X (5)	205 Vdc	123 °C	27	1577
W (6)	Without coils			

Tab.5 - Variants (7-9)

Code	Variant
S1	No variant
SV	Viton
LF (11)	Emergency control lever (see page 34)
LR	Emergency control lever 180° rotated (see page 34)
ES	Emergency button (see page 34)
P2 (9)	Rotary emergency button (see page 34)
R5 (9)	Rotary emergency b. 180° (see page 34)
3T	First elem. for series connec.
AJ (10)	AMP Junior connection (see page 105)
FL (10)	Coil with flying leads 250 mm (see page 105)
LD (10)	Coil with flying leads 130 mm and integrated diode (see page 105)
CX (10)	Deutsch connection with bidirectional diode (see page 105)

- (1) For series connection configuration, a special individual bankable valve CDC3*E04**3T2 (A B or G parallel body type only, with spool 04 type, 3T variant) must always be used as first element. For other individual bankable valve must use body D E or H connector series type with spool 04 only.
- (2) Specials with price increasing
- (3) Special voltage
- (4) Require connector with rectifier: 115 VAC/50Hz - 120 VAC/60Hz
- (5) Require connector with rectifier: 230 VAC/50Hz - 240 VAC/60Hz
- (6) Performance are guaranteed only using valves completed with coil
- (7) Connector to be ordered separately, see page 103;
Coils technical data, see page 105;
Voltage codes are not stamped on the plate, their are readable on the coils
- (8) Other variants available on request
- (9) Tightening torque max. 6÷9 Nm (CH n. 22)
- (10) Available in 12V or 24V DC voltage only
- (11) For the body type G - H - M order LR variant (Emergency control lever 180° rotated)

HYDRAULIC SYMBOLS

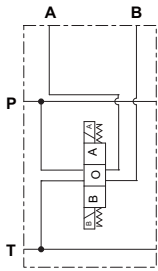

CDC3 A ... CDC3 B ...

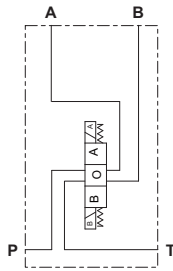

CDC3 D ... CDC3 E ...

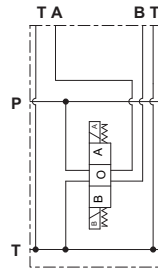

CDC3 G ...

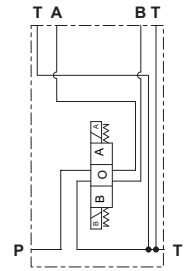

CDC3 H ...

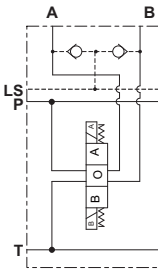

CDC3 I ...
CDC3 L ...

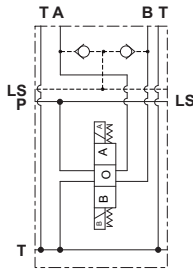

CDC3 M ...

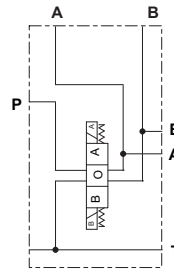

CDC3 S ...

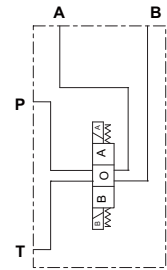

CDC3 U ...

HYDRAULIC SYMBOLS AND INSTRUCTION OF CONNECTION

PARALLEL CONNECTION

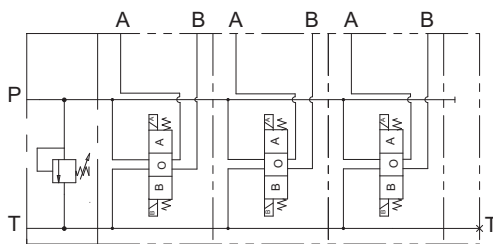
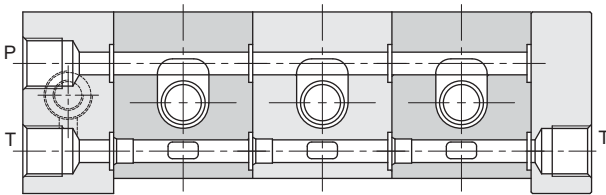

SERIES CONNECTION

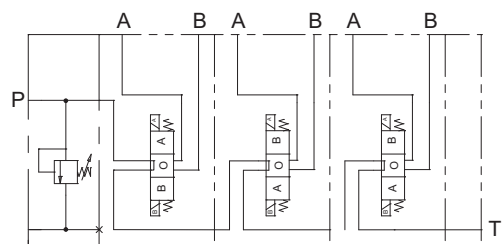
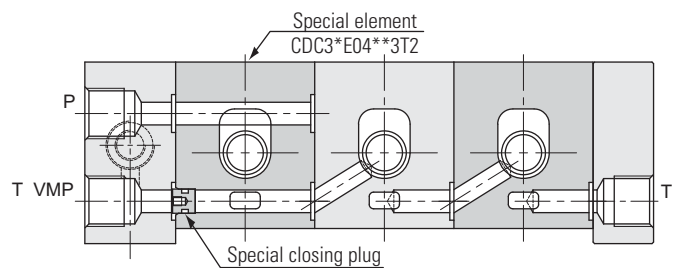

For series connection configuration, a special individual valve bank section (CDC3*E04**3T2) must always be used as first element (see ordering code page 25).

PRESSURE DROPS - DIRECTIONAL CONTROL BANKABLE VALVE

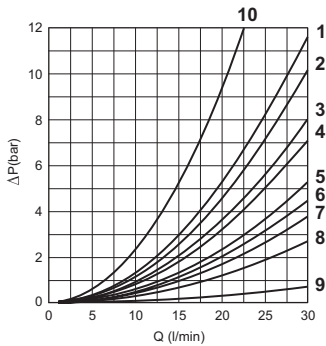

Spool type	Connections					
	P → A	P → B	A → T	B → T	P → T	P/T passing
01	4	4	4	4	—	9
02 (p)	7	7	6	6	7	9
02 (s)	7	7	6	6	8	—
03	4	4	6	6	—	9
04 (p)	2	2	1	1	5	9
04 (s)	2	2	1	1	3	—
15-16 (E)	6	6	10	10	—	9
15-16 (F)	6	6	5	5	—	9

Curve No.

The diagram at the side shows the pressure drop curves for spools during normal usage.

The fluid used is a mineral oil with a viscosity of 46 mm²/s at 40 C°; the tests have been carried out at a fluid temperature of 40 C°.

(p) Parallel connections

(s) Series connections

(E) Mounting E

(F) Mounting F

LIMITS OF USE (MOUNTING C-E-F)

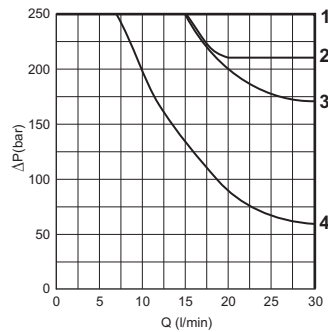

Spool type	Curve No.
01	1
02	1
03	3
04	2
15-16	1 (4)

(4) = 15 and 16 spools used as 2 or 3 way, follow the curve No. 4

The tests have been carried out with solenoids at operating temperature and a voltage 10% less than rated voltage with a fluid temperature of 50 C°. The fluid used was a mineral oil with a viscosity of 46 mm²/s at 40 degrees C. The values in the diagram refer to tests carried out with the oil flow in two directions simultaneously (e.g. from P to A and at the same time B to T).

In the cases where valves 4/2 and 4/3 are used with the flow in one direction only, the limits of use could have variations which may even be negative (See curve No 4 and Spool No 16 used as 2 or 3 ways). The tests were carried out with a counter-pressure of 2 bar at T port.

NOTE: The limits of use are valid for the C, E, F mounting.

OVERALL DIMENSIONS

Parallel body

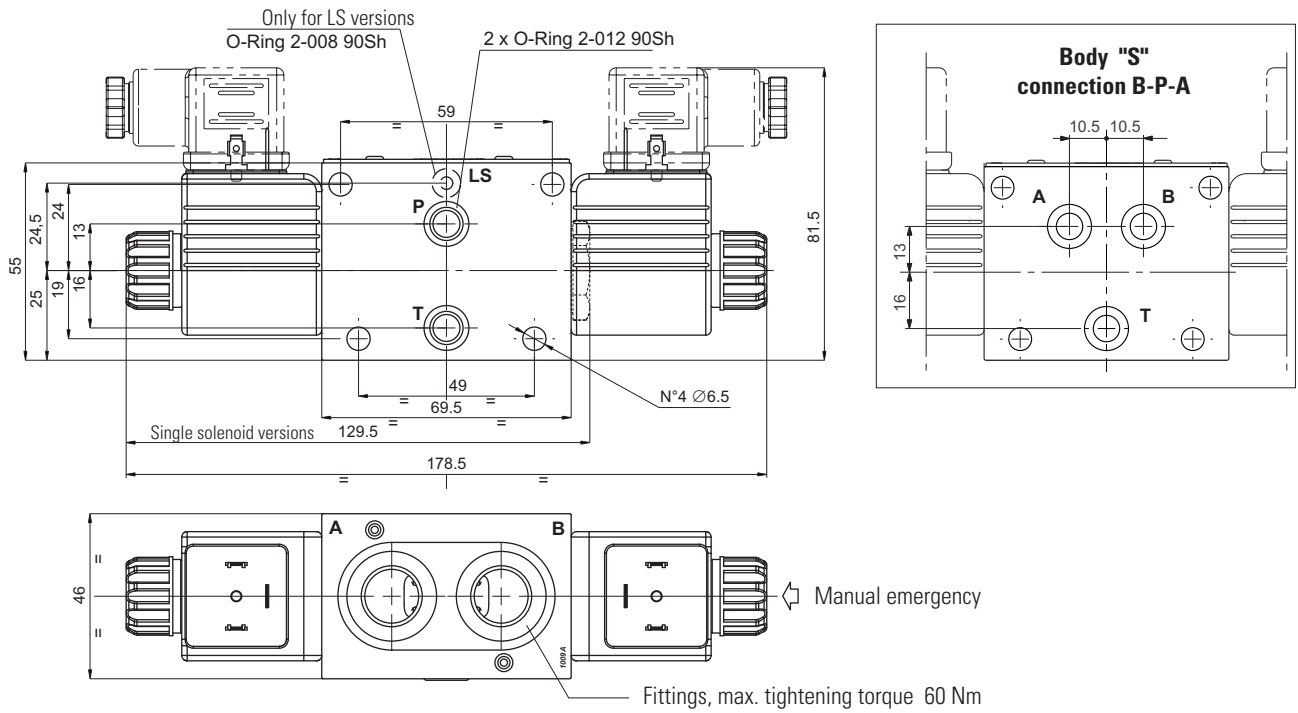

1

Parallel body Presetting for modular valves

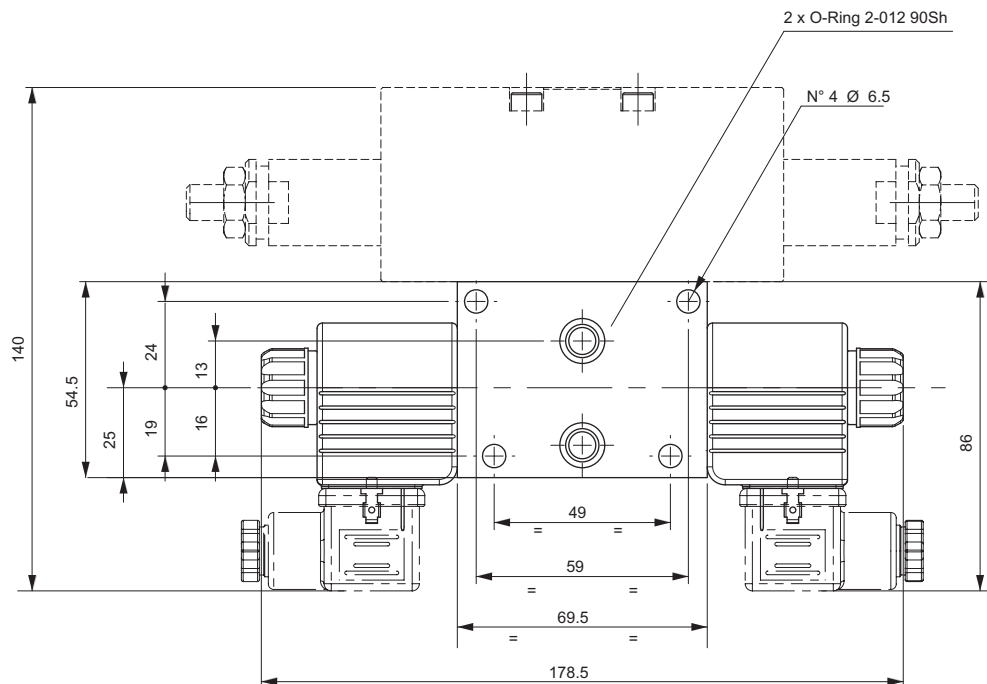

"LF" AND "LR" VARIANTS - EMERGENCY CONTROL LEVER

1



Thanks to his flexibility, the component is designed to be inserted between the valve body and the spool, providing total interchangeability between the different types of solenoid body valves manufactured by Dana Brevini. The control can be used as an emergency device in the event of power cuts.

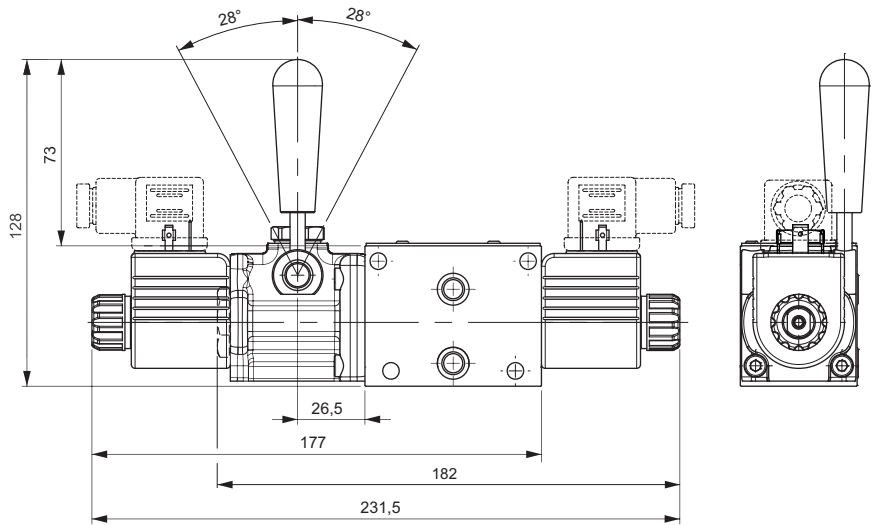

LF variant

HYDRAULIC SYMBOL



Max operating pressure port T	dynamic	160 bar
	static	210 bar
Max operating pressure port P for series connection configuration		160 bar
Mounting type		C - F - H
Spools type		01 - 02 04 - 16
Weight with single solenoid	CDC3	2.21 kg
	CDCM3	2.36 kg
Weight with double solenoid	CDC3	2.46 kg
	CDCM3	2.61 kg

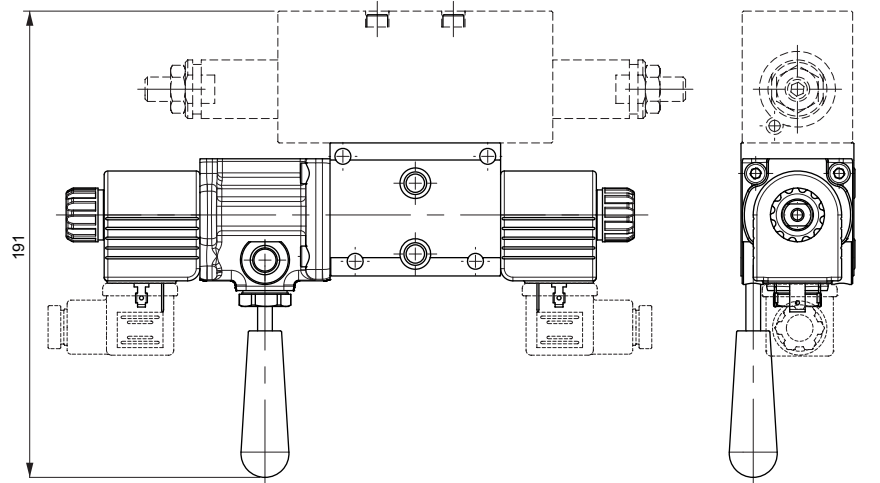

LR variant

OTHER VARIANTS

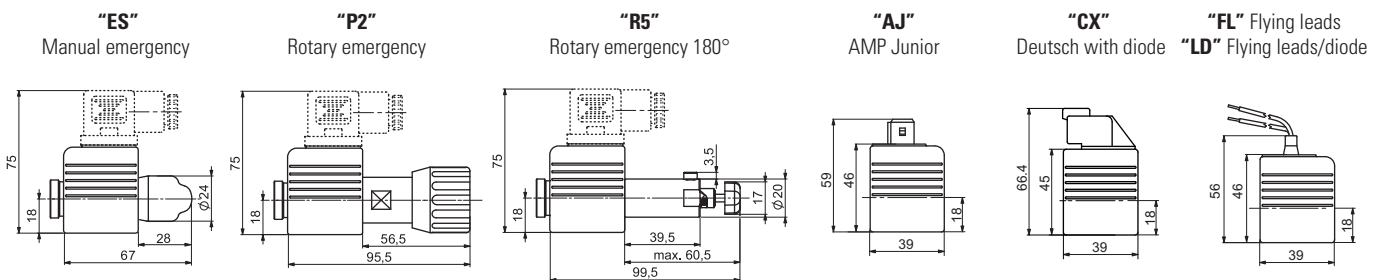

Emergency P2 and P5, tightening torque max. 6÷9 Nm (CH n. 22)