

CETOP 2/NG04

AD.2.E...	CH. I PAGE 4
"A09" DC COILS	CH. I PAGE 4
STANDARD CONNECTORS	CH. I PAGE 20

DIRECTIONAL CONTROL VALVES CETOP 2/NG4

The ARON directional control valves NG4 are designed for subplate mounting with an interface in accordance with UNI ISO 4401 - 02 - 01 - 0 - 94 standard (ex CETOP R 35 H 4.2-4-02), and are the smallest on the market in their category whilst still featuring excellent performance.

The use of solenoids with wet armatures ensures quiet operation, means that dynamic seals are no longer required and important levels of counter-pressure are accepted on the return line. The solenoid's tube is screwed at valve body directly, while a locking ring nut seal the coil in right position.

The cast body with a great care in the design and production of the ducts of the 5 chambers have made it possible to improve the spools allowing relatively high flow rate with low pressure drops (Δp).

The spool rest positions are obtained by means of springs which centre it when there is no electrical impulse. The solenoids are constructed to DIN 40050 standards and are supplied by means of DIN 43650 ISO 4400 standard connectors which, suitably assembled, ensure a protection class of IP 65.

The solenoid coils are normally arranged for DIN 43650 ISO 4400 type connectors (standard version). On request, could be available the following coil connection variants: AMP Junior connections; flying leads connections, with or without integrated diode; Deutsch connections with bidirectional integrated diode.

The supply may be in either DC or AC form (with the use of a connector and rectifier) in most common voltage.

The valves are designed for use with DIN 51524 standard hydraulic mineral oils and it is recommended that filters should be fitted to ensure a maximum contamination level of class 10 in accordance with NAS 1638, $\beta_{25} \geq 75$..

PRESSURE DROPS

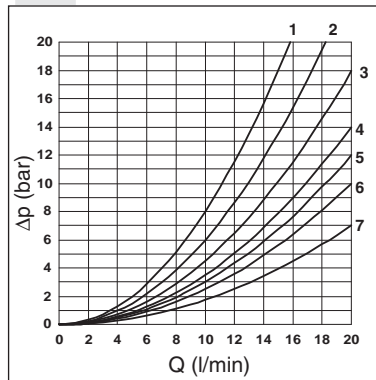

Spool type	Connections				
	P→A	P→B	A→T	B→T	P→T
01	4	4	6	6	
02	6	6	7	7	5
03	4	4	7	7	
04	1	1	2	2	3
05	6	6	4	4	
66	5	5	5	7	
06	5	5	7	5	
15	4	4	4	4	
16	5	5	6	6	
20*	5	5	6	6	

Curve No.

* = with energized spool

The diagram at the side shows the pressure drop curves for spools during normal usage. The fluid used is a mineral based oil with a viscosity of 46 mm²/s at 40°C; the tests have been carried out at a fluid temperature of 40°C. For higher flow rates than those in the diagram the losses will be those expressed by the following formula:

$$\Delta p_1 = \Delta p \times (Q_1/Q)^2$$

where Δp will be the value for the losses for a specific flow rate Q which can be obtained from the diagram, Δp_1 will be the value of the losses for the flow rate Q₁ that is used.

ORDERING CODE

AD	Directional valve
2	CETOP 2/NG4
E	Electrical operator
**	Spool (tables next page)
*	Mounting (table 1 next page)
*	Voltage (table 2 next page)
**	Variants (table 3 next page)
3	Serial No.

TAB. 1 MOUNTING

STANDARD	
C	
D	
E	
F	
SPECIALS (WITH PRICE INCREASING)	
G	
H	
I	
L	
M	

TAB.3 - VARIANTS

VARIANT	CODE
No variant (without connectors)	S1(*)
Viton	SV(*)
Emergency button	ES(*)
Rotary emergency button	P2(*)(**)
AMP Junior connection	AJ(*)
Solenoid with flying leads (250 mm)	FL
Solenoid with flying leads (130 mm) and integrated diode	LD
Deutsch connection with bidir. diode	CX
Coil 8W (only 24V)	8W
Other variants available on request.	

(*) Coils with Hirschmann and AMP Junior connection supplied without connectors. The connectors can be ordered separately, ch. I page 20.

(**) P2 Emergency tightening torque max. 6÷9 Nm / 0.6 ÷ 0.9 Kgm with CH n. 22

- Mounting type D is only for solenoid valves with detent
- In case of mounting D with detent, the supply to solenoid must be longer than 100 ms.

- The AMP Junior coil, the Deutsch coil with bidirectional diode and the coil with flying leads (with or without diode) coils are available in 12V or 24V DC voltage only.

* Special voltage
** Technical data see page I • 4

TAB.2 - A09 (27 W) COIL

DC VOLTAGE **	
L	12V
M	24V
N	48V*
P	110V*
Z	102V*
X	205V*
W	Without DC coils

115Vac/50Hz
120Vac/60Hz
with rectifier

230Vac/50Hz
240Vac/60Hz
with rectifier

Voltage codes are not stamped on the plate, they are readable on the coils.

LIMITS OF USE (MOUNTING C-E-F)

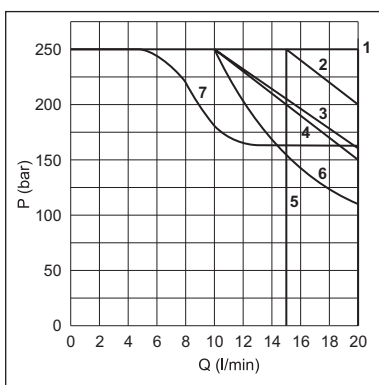

Spool Type	Curves No
01	1
02	3
03	1
04	4
05	1
66	1
06	1
15	1(7*)
16	2(6*)
20	5

(6*) = 16 spool used as 2 or 3 way, follow the curve n°4
(7*) = with 8W coil

The tests have been carried out with solenoids at operating temperature and a voltage 10% less than rated voltage with a fluid temperature of 40°C. The fluid used was a mineral oil with a viscosity of 46 mm²/s at 40°C. The values in the diagram refers to tests carried out with the oil flow in two directions simultaneously (e.g. from P to A and at the same time B to T). In case of valve 4/2 or 4/3 used with flow in one direction only, the limits of use could have variations which may even be negative.

Medium switching times Energizing: 20 ms
De-energizing: 40 ms

Tests have been carried out by spool normally closed with flow of 10 l/min at 125 bar and a 100% supply, warm standard coil and without any electronic components. These values are indicative and depend on the following parameters: the hydraulic circuit, the fluid used and the variation of pressure, flow and temperature.

NOTE: Limits of use are available for C, E, F mounting.

STANDARD SPOOLS

TWO SOLENOIDS, SPRING CENTRED "C" MOUNTING			
Spool Type		Covering	Transient position
01		+	
02		-	
03		+	
04*		-	
05		+	
66		+	
06		+	

ONE SOLENOID, SIDE A "E" MOUNTING			
Spool Type		Covering	Transient position
01		+	
02		-	
03		+	
04*		-	
05		+	
66		+	
06		+	
15		-	
16		+	

ONE SOLENOID, SIDE B "F" MOUNTING			
Spool Type		Covering	Transient position
01		+	
02		-	
03		+	
04*		-	
05		+	
66		+	
06		+	
15		-	
16		+	

TWO SOLENOIDS "D" MOUNTING			
Spool Type		Covering	Transient position
20*		+	

* SPOOLS WITH PRICE INCREASING

1

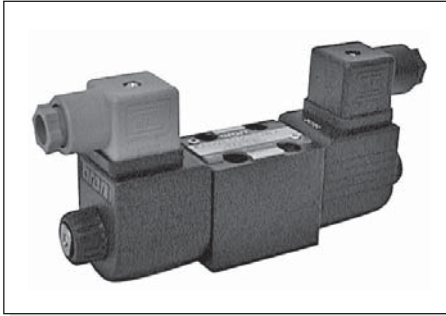

Max. pressure ports P/A/B	250 bar
Max pressure port T (dynamic)	250 bar
Max flow	20 l/min
Max excitation frequency	3 Hz
Duty cycle	100% ED
Fluid viscosity	10 ÷ 500 mm ² /s
Fluid temperature	-25°C ÷ 75°C
Ambient temperature	-25°C ÷ 60°C
Max contamination level	class 10 in accordance with NAS 1638 with filter β ₂₅ ≥ 75
Weight with one DC solenoid	0,88 Kg
Weight with two DC solenoids	1,1 Kg

E = Manual override

Screws with material specifications min. 8.8 recommended - UNI 5931
Tightening torque of screws M5x35 = 5 Nm / 0.5 Kgm.

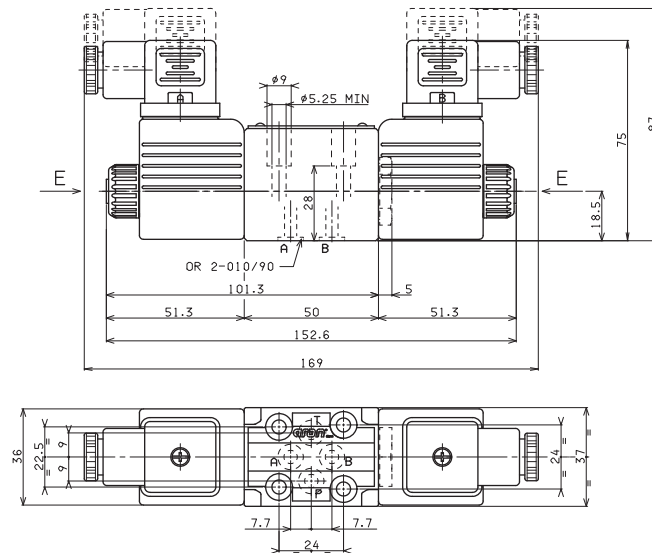

Support plane specifications

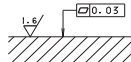

DC COILS A09

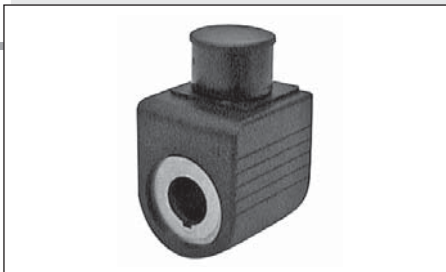

Type of protection (in relation to connector used)	IP 65
Number of cycle	18.000/h
Supply tolerance	±10%
Ambient temperature	-30°C ÷ 50°C
Duty cycle	100% ED
Insulation class wire	H
Weight	0,215 Kg

• The AMP Junior coil, the Deutsch coil with bidirectional diode and the coil with flying leads (with or without diode) coils are available in 12V or 24V DC voltage only.

AMP JUNIOR (AJ)

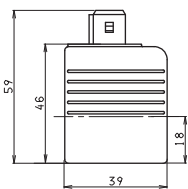

VOLTAGE (V)	MAX WINDING TEMPERATURE (AMBIENT TEMPERATURE 25°C)	RATED POWER (W)	RESISTANCE AT 20°C (OHM) ±7%
12V	123°C	27	5.3
24V	123°C	27	21.3
48V*	123°C	27	85.3
102V(*)(**)	123°C	27	392
110V(*)(**)	123°C	27	448
205V(*)(**)	123°C	27	1577

* Special voltages

** The european low voltage directive is applied to electrical equipments used at a nominal voltages between 50 and 1000 VAC or 75 and 1500 VDC. In conformity with the low directive each part of the manifold or the subplate on which the valve is mounted should be connected to a protective earth with a resistance less than 0.1 ohms.

DEUTSCH COIL WITH BIDIR. DIODE (CX) DT04 - 2P

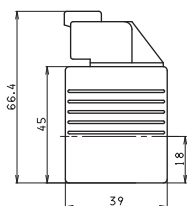

FLYING LEADS (FL) LEADS WITH DIODE (LD)

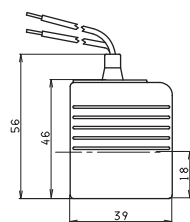

EMERGENCY (COILS WITH HIRSCHMANN CONNECTION)

MANUAL WITHOUT CONNECTOR (ES)
MANUAL WITH CONNECTOR (E1)

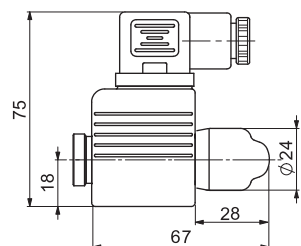

ROTARY WITHOUT CONNECTOR (P2*)
ROTAN ROTARY WITH CONNECTOR (P1*)

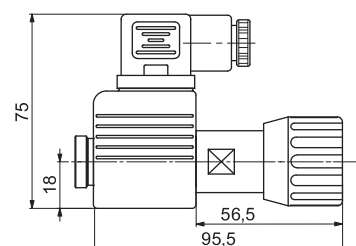

(*) Emergency tightening torque max. 6±9 Nm / 0.6 ÷ 0.9 Kgm with CH n. 22