



BREVINI[®]

Motion Systems

FP HYDRAULIC POWER PACK

Technical Catalogue

January
2018

web edition

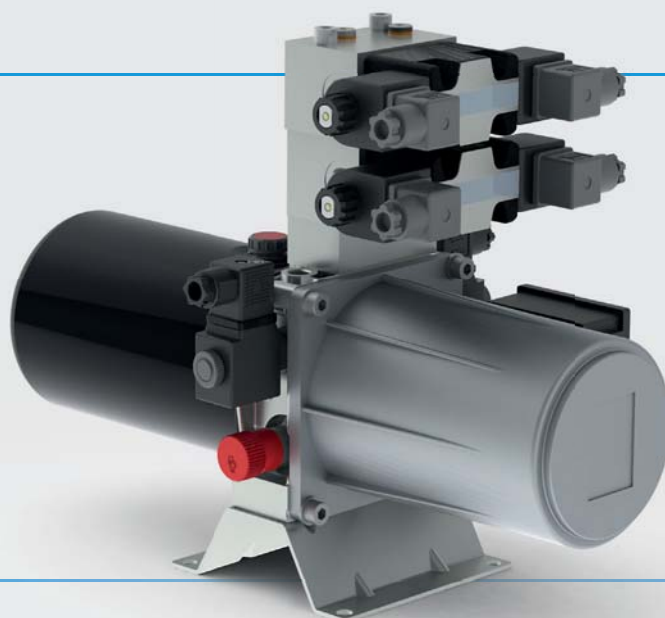



| | |
|---|---------------|
| Introduction | 2 |
| Endhead configuration | 3 |
| Power pack sections | 7 |
| Selection code | 8 |
| Endhead overall dimensions | 11 |
| Cavities dimensions | 12 |
| SELECTIONS FOR "FPA" POWER PACK ENDHEAD | |
| Sect. I - FPA Cavity 1 | 14 |
| Sect. II - FPA Cavity 2 | 15 |
| Sect. II - FPA Cavity 5 | 18 |
| Sect. II - FPA Cavities 6-7 | 19 |
| Sect. II - FPA Ports A-B | 20 |
| SELECTIONS FOR "FPC" POWER PACK ENDHEAD | |
| Sect. I - FPC Cavity 1 | 21 |
| Sect. II - FPC Cavity 2 | 22 |
| Sect. II - FPC Cavity 3 | 25 |
| Sect. II - FPC Cavity 4 | 28 |
| Sect. II - FPA Cavity 5 | 18 |
| Sect. II - FPC Cavity 6-7-8-9 | 32 |
| Sect. II - FPC Ports A-B-C | 33 |
| SELECTIONS FOR "FPL" POWER PACK ENDHEAD | |
| Sect. I - FPL Cavity 1 | 34 |
| Sect. II - FPL Cavity 2 | 35 |
| Sect. II - FPL Cavity 3 | 38 |
| Sect. II - FPL Cavity 4 | 41 |
| Sect. II - FPL Cavity 7-8 | 44 |
| Sect. II - FPC Ports A-B-C | 33 |
| SELECTIONS FOR "FPE" POWER PACK ENDHEAD | |
| Sect. I - FPE Cavity 1 | 46 |
| Sect. II - FPE Cavity 2 | 47 |
| Sect. II - FPE Cavity 3 | 49 |
| Sect. II - FPE Cavity 9 | 51 |
| Sect. II - FPL Ports A-B-C-D | 45 |
| SELECTIONS FOR ALL POWER PACK ENDHEADS | |
| Sect. III - Pumps | 53 |
| Sect. IV - Tanks / Sect. V - Tubes kit | 55 |
| Sect. VI - DC Motors | 71 |
| Sect. VI - AC Motors | 77 |
| Sect. VII - Transmission kit | 83 |
| Sect. VIII - Blocks and CETOP valves | 85 |
| Sect. IX - Accessories | 89 |
| Examples | 90 |

© 2018 Dana Brevini S.p.A. all rights reserved. Hydr-App, SAM Hydraulik, Aron, Brevini Hydraulics, BPE Electronics, VPS Brevini, OT Oiltechnology, logos are trademarks or are registered trademarks of Dana Brevini S.p.A. or other companies Dana in Italy and other countries.

The technical features supplied in this catalogue are non binding and no legal action can be taken against such material. Dana Brevini will not be held responsible for information and specifications which may lead to error or incorrect interpretations. Given the continuous technical research aimed at improved technical features of our products, Dana Brevini reserves the right to make change that are considered appropriate without any prior notice. This catalogue cannot be reproduced (in whole or in part) without the prior written consent of Dana Brevini. This catalogue supersedes all previous ones.

Use of the products in this catalogue must comply with the operating limits given in the technical specifications. The type of application and operating conditions must be assessed as normal or in malfunction in order to avoid endangering the safety of people and/or items..



The FP series power pack is an easy-to-assemble, compact, electro-hydraulic unit. With its versatility and modularity, it offers many combinations of hydraulic circuits to suit various requirements of plant design. This catalogue has been written to help the user choose the components for the power pack required for the specific application. However, the catalogue cannot foresee all the combinations that may be executed, so in some cases it may be necessary to consult our commercial engineering department.

For applications with very complex circuits, standard modular blocks for Cetop valves and other special blocks can be installed on the power pack, or blocks built to order can be included.

A few applications:

- Fork lifts
- Lifting platforms and beds
- Automotive lifts
- Cranes for small trucks
- Snowplows
- Industrial automation (machine tools, food industry, textile industry)

You can choose from a wide variety of components with the following specifications:

- Gear pumps - Group 05 / 1 - from 0.25 to 9.8 cc.
- DC motors, 12/24 V, light-duty service, from 0.35 to 3 Kw
- Single and triple-phase motors with power ratings of up to 4 Kw - in a standard version or built to the customer's specifications (with minimum overall dimensions)
- Tanks in sheet steel with capacities of up to 25 litres
- Tanks in plastic with capacities of up to 10 litres

A fundamental part of the power pack is the endhead, which is made of die-cast aluminum alloy. The parts and dimensions of this component are shown below.

Operating limits

- Intermittent peak pressure: 290 bar (depending on pump type)
- Maximum flow rate: 20 l/min
- Maximum operating temperature:
 - 80°C (with sheet steel tank)
 - 70°C (with polyethylene tank)
 - 60°C (with polypropylene tank)
- Mineral-based hydraulic fluid: ISO 6743-4 (DIN 51524)
 - Minimum viscosity: 12 mm²/s
 - Maximum viscosity: 80 mm²/s
 - Maximum viscosity at start-up: 500 mm²/s
- Minimum ambient temperature – 15°C
- Maximum ambient temperature 40°C (with peaks of 50°C)

The validation of the endhead follows a life-test with 250 bar pulsed pressure repeated for 100.000 cycles



Operating pressure is controlled by the maximum pressure valve and the type of pump used (in terms of performance) may be determined by the maximum pressure valve. Therefore, it is essential not to change the maximum pressure valve. If necessary, contact our technical service department

Installation

- 1) The power pack must be mounted using the M10 holes on the endhead.
- 2) The power pack must not come into contact with sheet metal, protective guards or any parts that may vibrate and transmit noise.
- 3) The ports on the endhead have been identified by the letters A-B-C. The hydraulic connection must be made with fittings with cylindrical thread and with copper or rubber sealing gaskets (O-rings).
- 4) After the electrical connections have been made, check the direction of motor rotation by executing short pulses of 1 second each (max.): the motor must turn anti-clockwise, as shown in the figure.

The tank must be filled with new mineral-based, ISO 6743/4 fluid: it is important to filter the fluid while filling the tank.

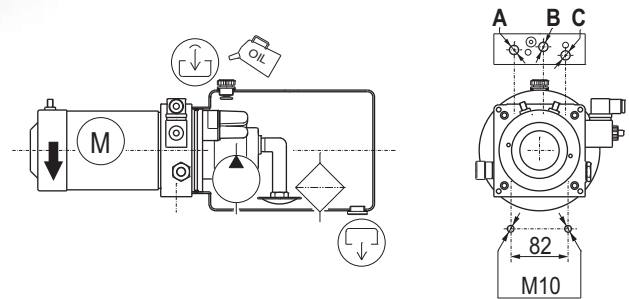

Symbols used in this catalog:

| | |
|---|---|
| | Important data/information |
| | Mounting endhead side |
| | Ground floor |
| | Electrical connection boxes on AC motors |
| | Poles and/or starting relays on DC motors |
| | Fill plug with breather and level stick |
| | Fill plug with breather |
| | Standard plug (closed) |
| | Standard oil fill plug |
| | Fill plug with breather |
| | Fill plug |
| | Fill plug with check valve |
| | Fill plug with back check |
| | Drain plug with magnet |
| | Plug (or level stick) with visual indicator |
| | Drain plug |
| * | Fields to be completed |

Power pack configuration

endhead **FPA**

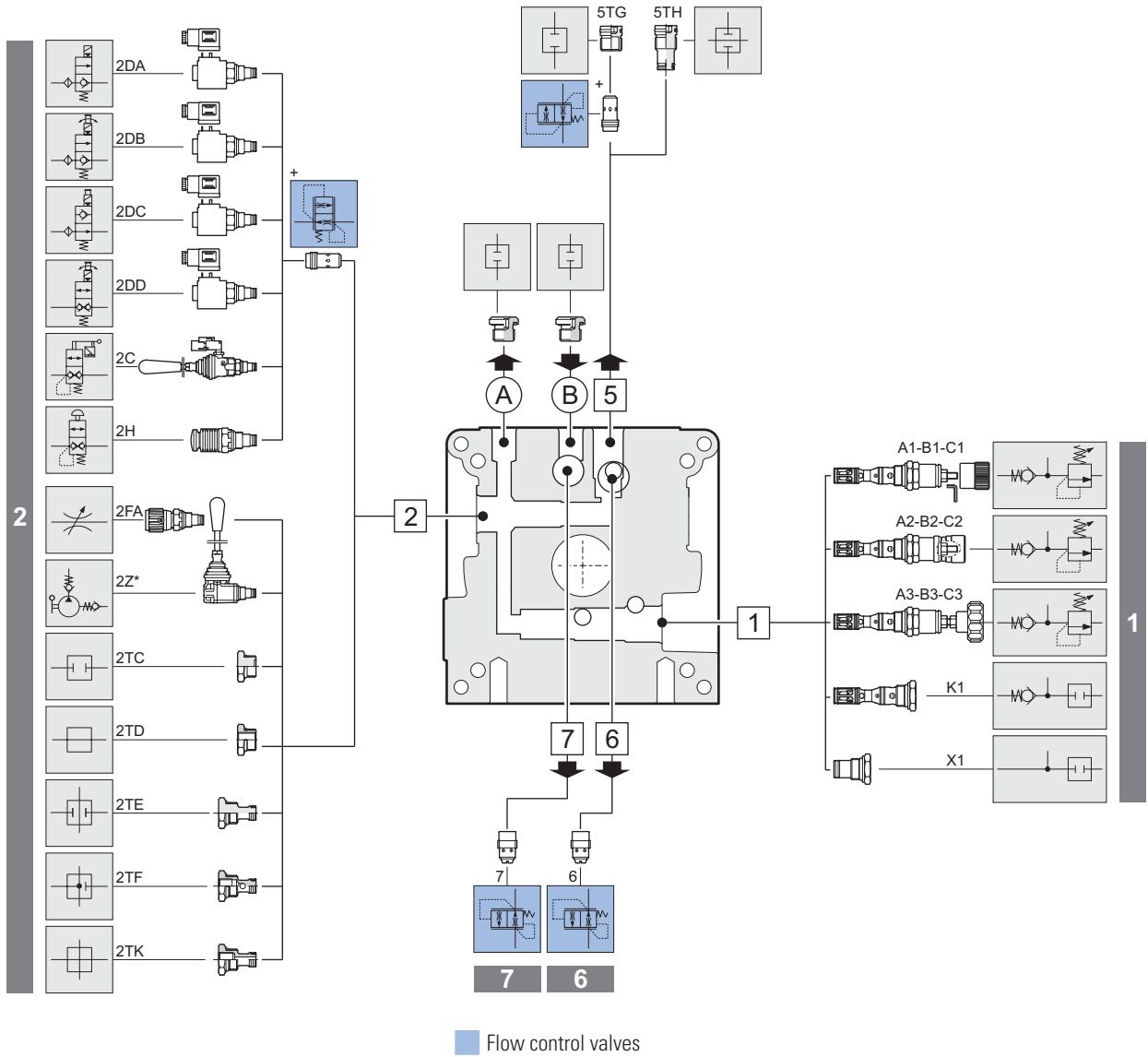

i

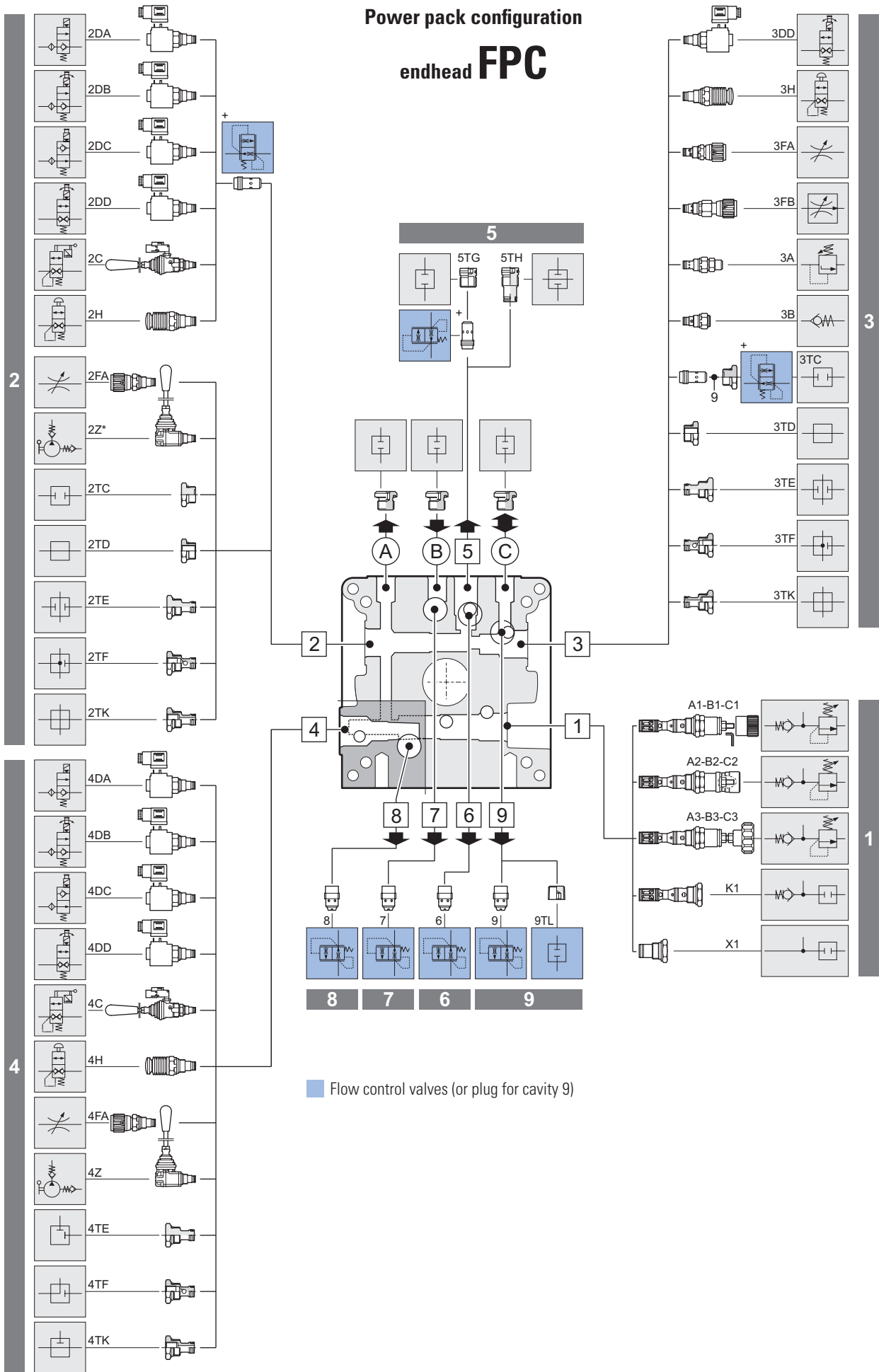

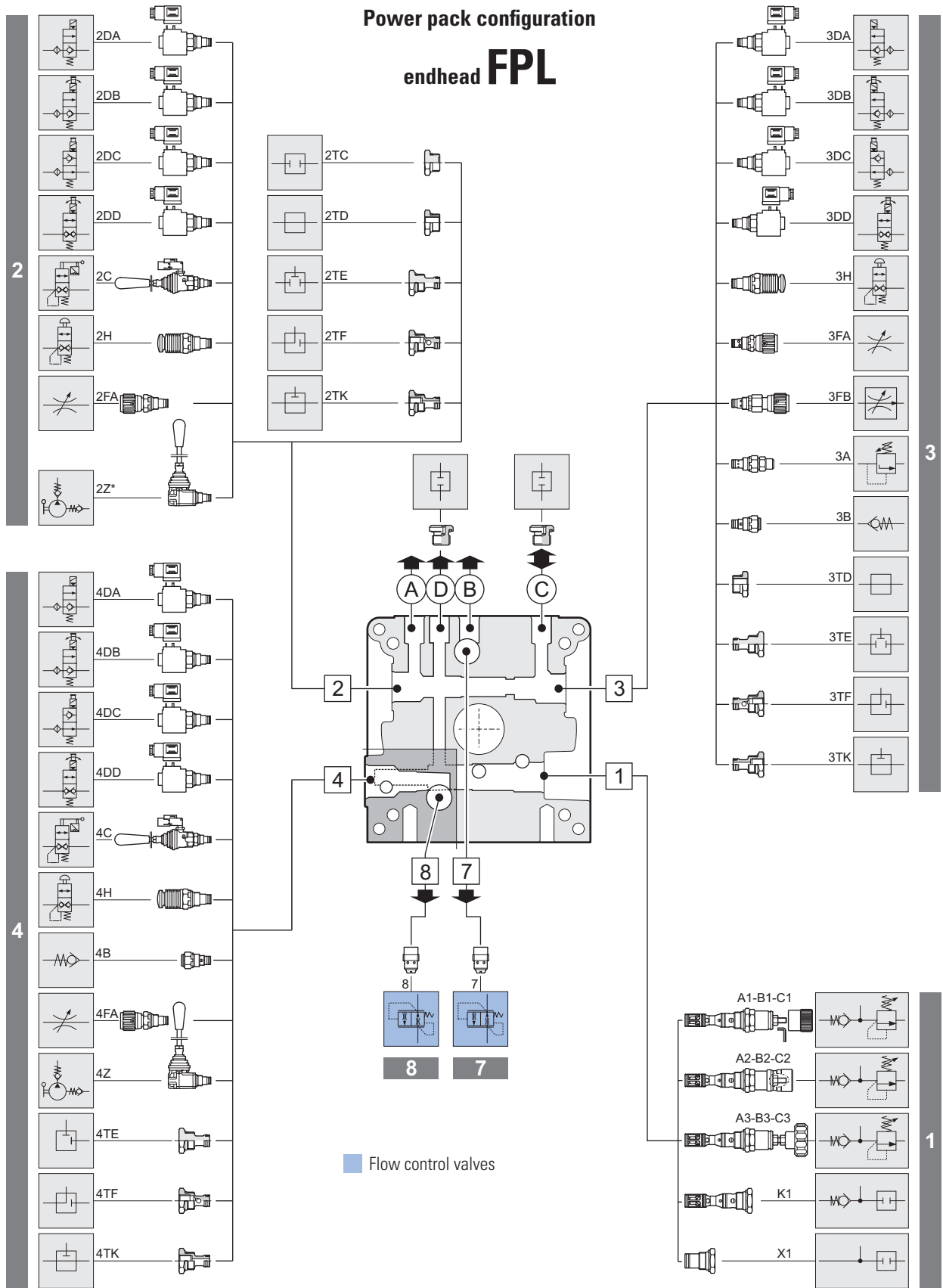



Power pack configuration endhead **FPE** (for directional control valves)

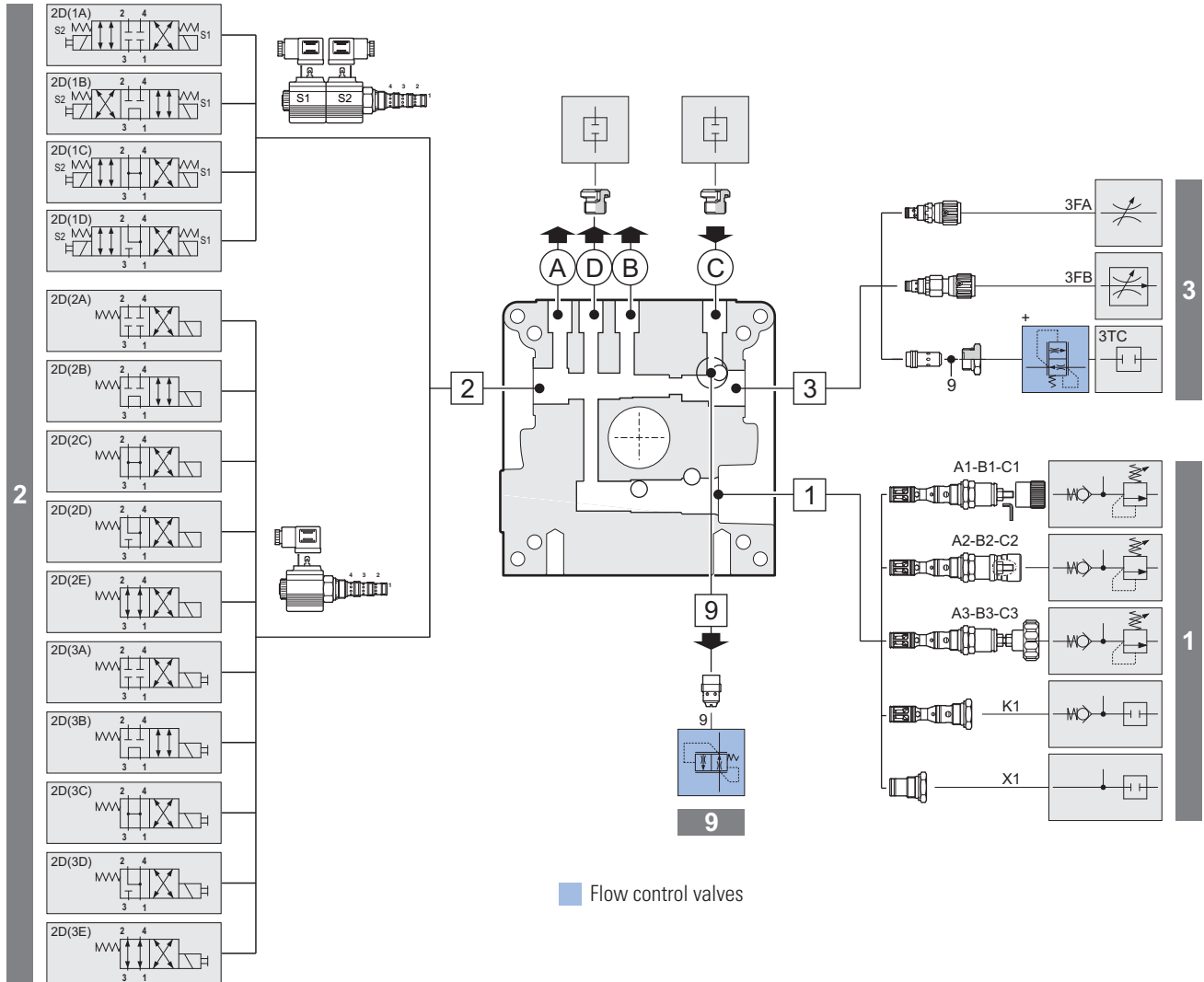

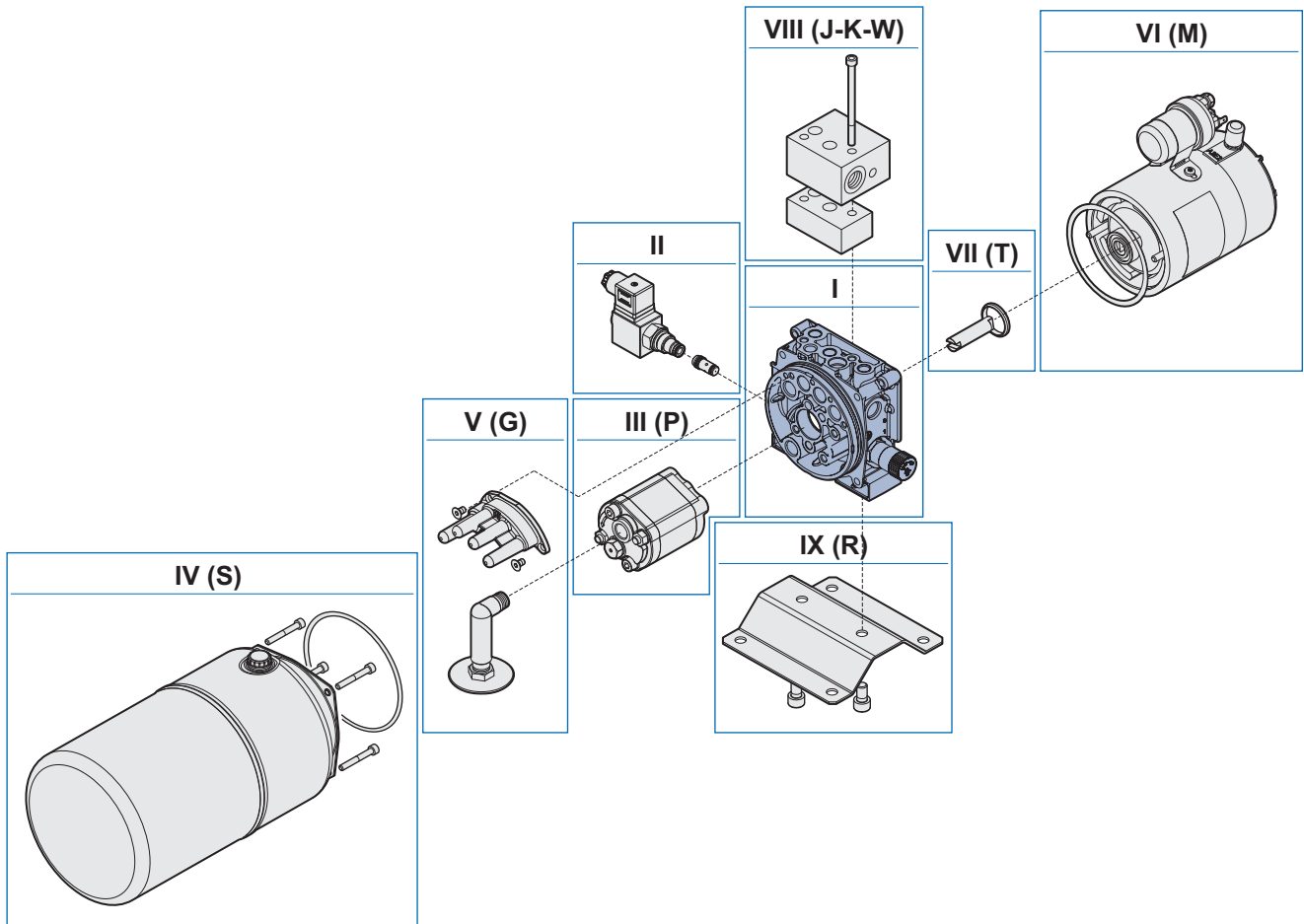

With its great modularity, the FP series of power packs can create multiple configurations which satisfy requirements in a wide range of applications. To make it easier to choose components, the power pack is subdivided into sections.

SECTION I - SERIE, FLANGE TYPE, VALVES ON CAVITY 1

FP Series Powerpacks are based on the Flange features. The Flange is the core of the unit, on the flange are mounted all the valves, the pump, the motor and the reservoir. The FP Flange is available in several Versions (with different tooling options). The Flange Version must be chosen depending on the type of Hydraulic Circuit Layout required. Together with the Flange Version, it is required to select the Valves to be mounted in the Various Cavities. 1 (Main Pressure Relief Valve).

SECTION II - VALVES

Depending on the Type of Hydraulic Circuit Layout to be realized, it is required to Select the Valves for each of the available Cavities. In order to correctly build up the Ordering Code, it is required to use the following procedure. Peripheral Cavities (it is mandatory to mention all the Cavities in Numeral Order): starting from Cavity 2, mention all the Cavities and the Valves, Plugs or Fittings to be mounted in said Cavity. Internal Cavities: normally connected to Tank (It is not mandatory to mention, but if required it should be done in Numeral Order): starting from Cavity 6, mention all the Internal Cavities where a Valve (usually a Return Line Valve) is mounted, Selecting the Valve Type to be mounted in said Cavity. Outputs, see description in the Table.

SECTION III - PUMPS

It is mandatory to mention this section, defined by the letter P. Depending on the required features, select the pump from the table provided.

SECTION IV - TANKS

This section is defined by the letter S. Depending on the required features, select the reservoir from the list provided. If no Reservoir is required, and also no Suction / Return Kit is required, please omit this section. If no Reservoir is required, but a Suction / Return Kit is required, please jump to Section V (defined by letter G).

SECTION V - TUBES KIT (suction and return, only for tanks on the catalog)

This section is defined by the letter G. In order to define this Section, please select the Reservoir Type anyways.

SECTION VI - MOTORS

This section is defined by the letter M. Depending on the Type of Hydraulic Circuit Layout to be realized, it is required to Select the Motor Type. If no Motor is required, and no Transmission Kit is required, please omit this section. If no Motor is required, but a Transmission Kit is required, please jump to Section VII (defined by letter T).

SECTION VII - TRANSMISSION KIT (only for motors on the catalog)

This section is defined by the letter T. Select the kit as per Table provided.

SECTION VIII - BLOCKS

This section it is not mandatory, depending on the Type of auxiliary Block required, definition Letter changes:
J, Blocks with CETOP type of interface for Solenoid Valves;
K, Bankable Valves Interface – Horizontal (Parallel to Unit Axis);
W, Bankable Valves Interface – Vertical (Perpendicular to Unit Axis);

SECTION IX - ACCESSORIES

his section it is not mandatory, is defined by the letter R. Check the available options in the list provided. Accessories must be listed in Alphabetical Order.

SECTION I - SERIE, ENDHEAD, VALVES ON CAVITY 1

i

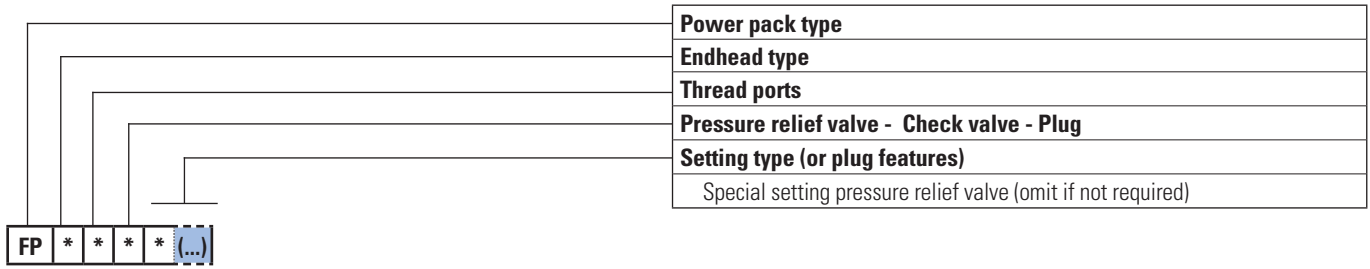

SECTION II - VALVES

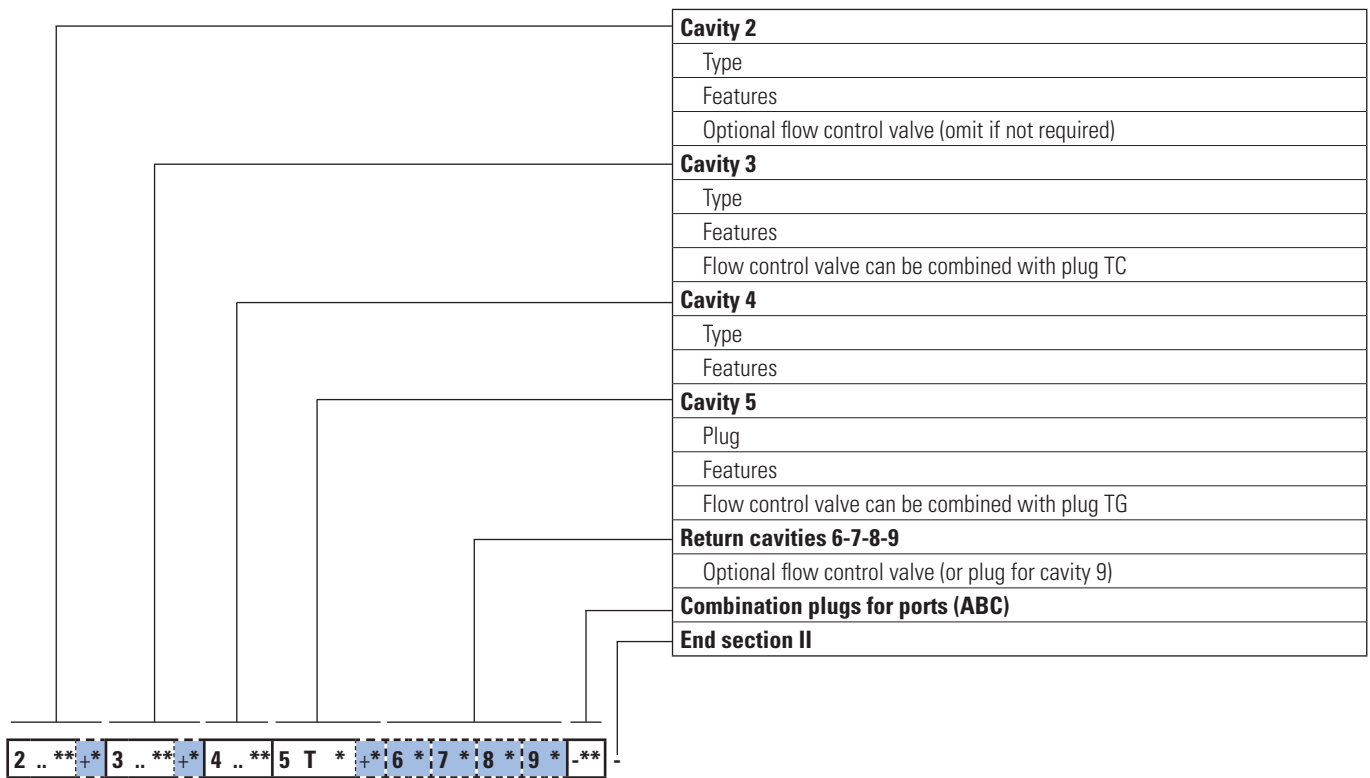

SECTION III - PUMPS

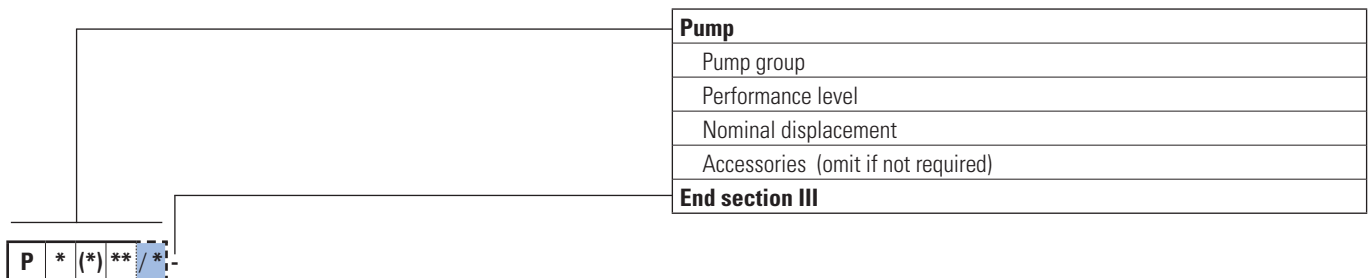

SECTION IV - TANKS / SECTION V - TUBES KIT

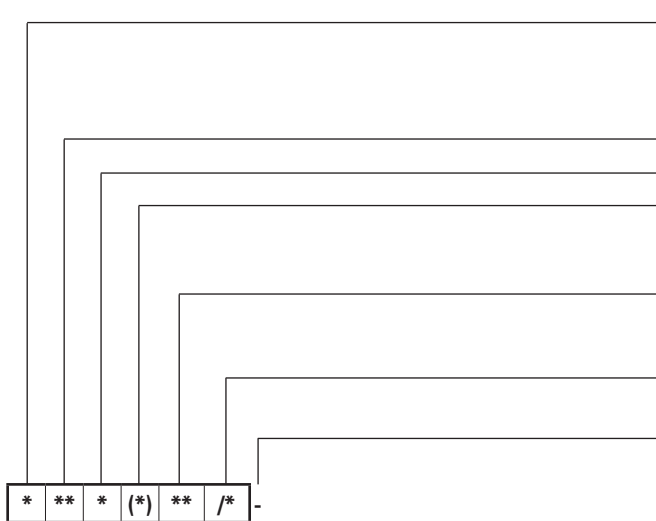
| | |
|---|--|
|  | Section: S = tank (with tubes kit); G = only with tubes kit, without tank; OMIT if without tank and without tubes kit |
| | Capacity liters |
| | Features (material and construction) |
| | Mounting position: H = horizontal; V = vertical |
| | Variants 00 = standard, no variant; OMIT if with tubes kit (section "G") |
| | Orientation OMIT if with tubes kit in vertical mounting position (section "G") |
| | End section IV and V |

SECTION VI - MOTORS

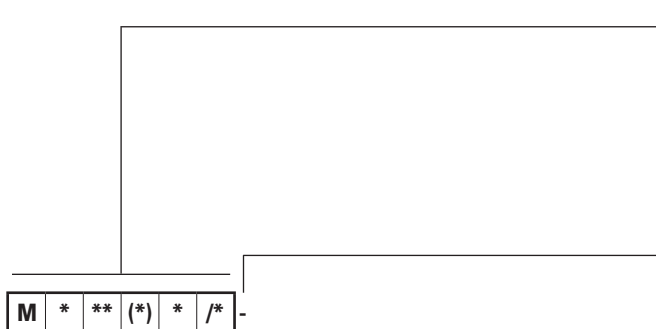
| | |
|--|--|
|  | DC motor |
| | Voltage |
| | Power / Size |
| | Version |
| | Accessories 0 = whitout accessories; |
| | Orientation |
| End section VI | |

OR ..

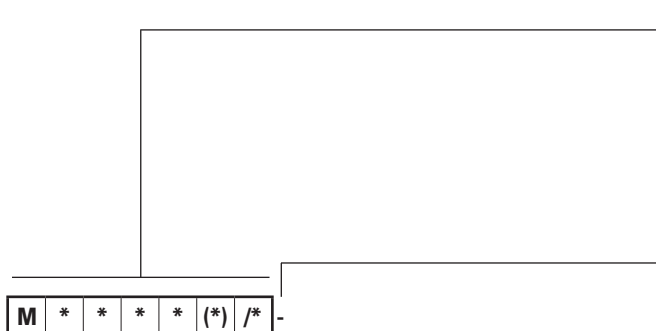
| | |
|---|-----------------|
|  | AC motor |
| | Phases |
| | Poles |
| | Size |
| | Power range |
| | Version |
| | Orientation |
| End section VI | |

SECTION VII - TRANSMISSION KIT (only for motors on the catalog)

i

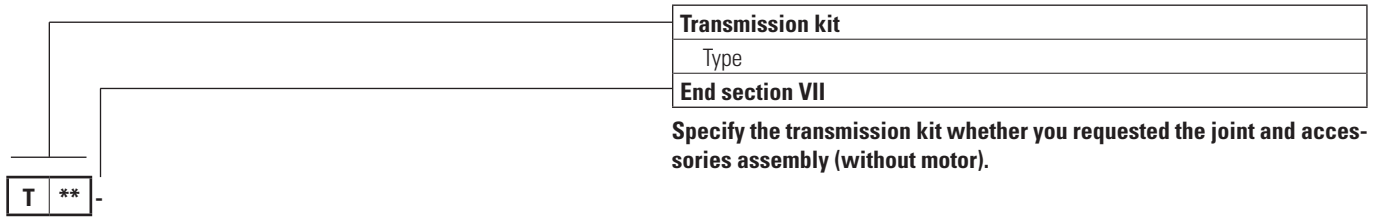

SECTION VIII - BLOCKS

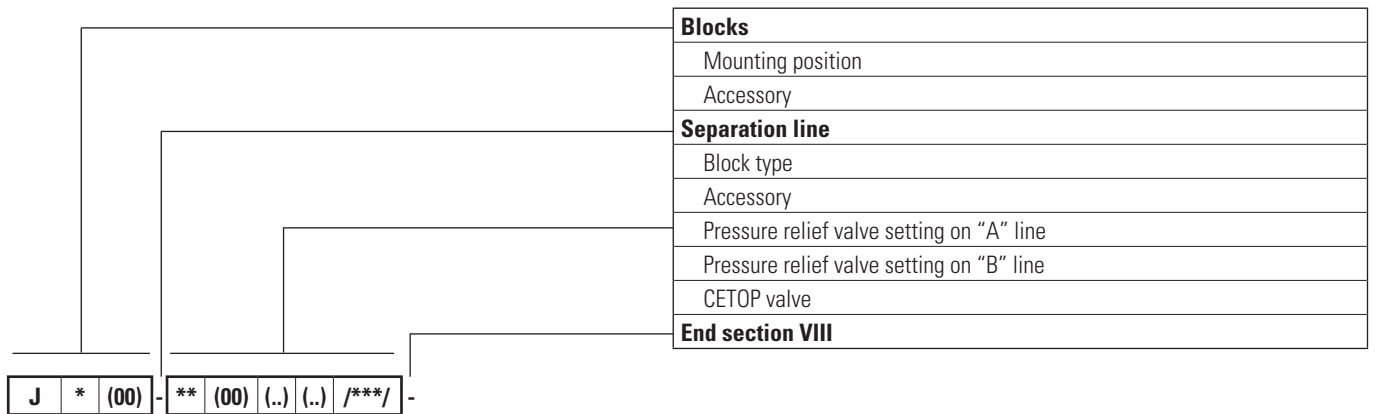

SECTION IX - ACCESSORIES

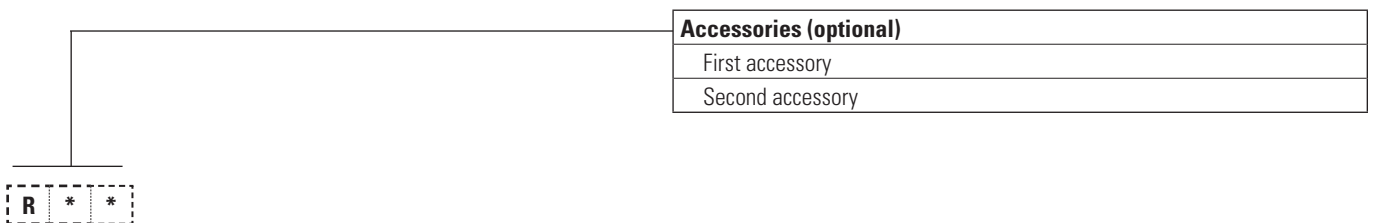

Endhead overall dimensions

Cavities on endhead:

| Cavity | Thread | Endhead type | | | |
|-------------------------|------------------------|--------------|-----|-----|-----|
| | | FPA | FPC | FPL | FPE |
| A Ports | G1/4" (1) G3/8" (2) | • | • | • | • |
| B Ports | G1/4" (1) G3/8" (2) | • | • | • | • |
| C Ports | G1/4" (1) G3/8" (2) | — | • | • | • |
| D Ports | G1/4" (1) | — | — | • | • |
| 1 Peripheral | 3/4" 16 UNF | • | • | • | • |
| 2 Peripheral | 3/4" 16 UNF | • | • | • | • |
| 3 Peripheral | 3/4" 16 UNF | — | • | • | • |
| 4 Peripheral | 3/4" 16 UNF | — | • | • | — |
| 5 Peripheral (2) | M16x1.5 | • | • | — | — |
| 6 Return | G3/8" | • | • | — | — |
| 7 Return | G3/8" | • | • | • | — |
| 8 Return | G3/8" | — | • | • | — |
| 9 Return | G3/8" | — | • | — | • |

1) blocks interface

2) available only for FPA - FPC endhead

3) the cavity 5 is not accessible with blocks mounted (section IX).

The number of cavities tooled identify the endhead type:

There are three types of cavities:

- **Peripheral cavities**, which can be accessed externally
- **Return cavities**, inside of the tank.
- **Ports**

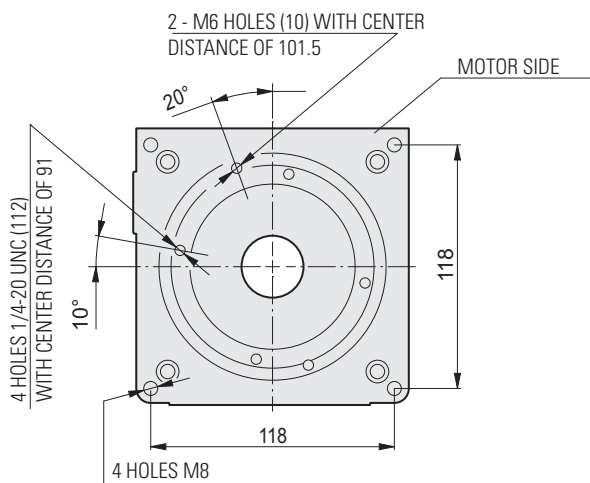
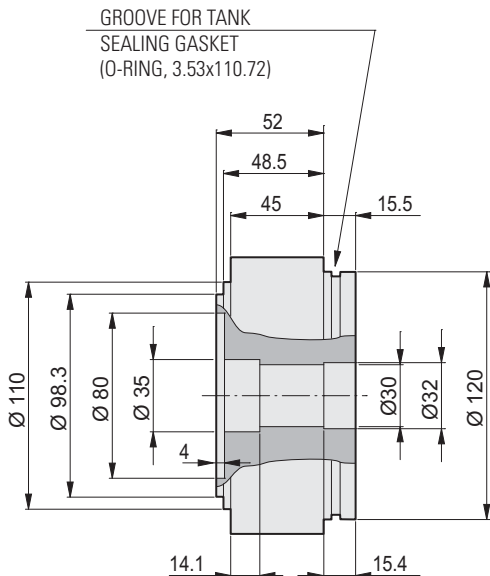
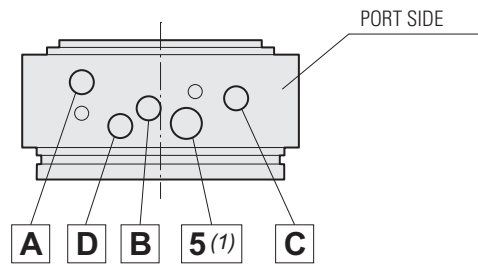
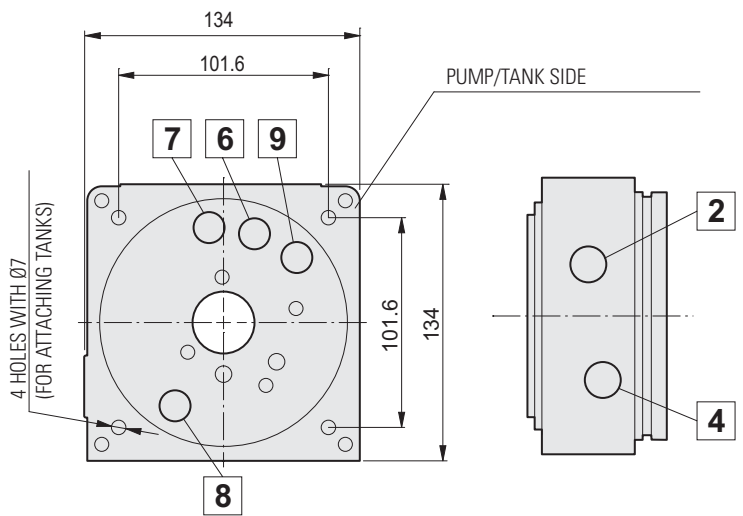
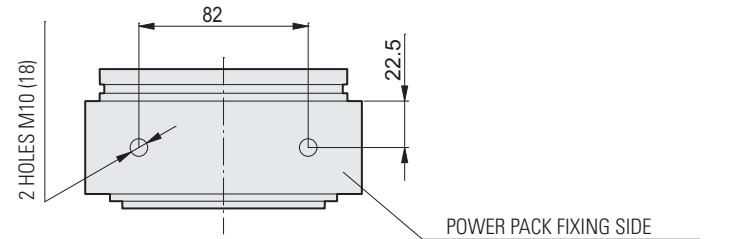
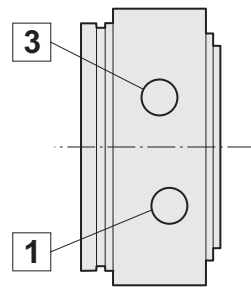

The cavities (1-2-3-4-5) and the ports (A-B-C) are marked on the die-cast endhead. The dimensions on the drawing are the same for all endhead.

Cavities dimensions

i

| Cavity | Thread | Drawing | Cavity | Thread | Drawing |
|------------------------|------------|-----------------|--------------|---------|---------|
| 1 Peripheral | 3/4 16 UNF | <p>CD018013</p> | 5 Peripheral | M16x1.5 | |
| 2 Peripheral (FPA-FPC) | 3/4 16 UNF | <p>CD018009</p> | 6 Return | G3/8 | |
| 2 Peripheral (FPE) | 3/4 16 UNF | <p>CD018001</p> | 7 Return | G3/8 | |
| 3 Peripheral | 3/4 16 UNF | <p>CD018014</p> | 8 Return | G3/8 | |
| 4 Peripheral | 3/4 16 UNF | <p>CD018014</p> | 9 Return | G3/8 | |

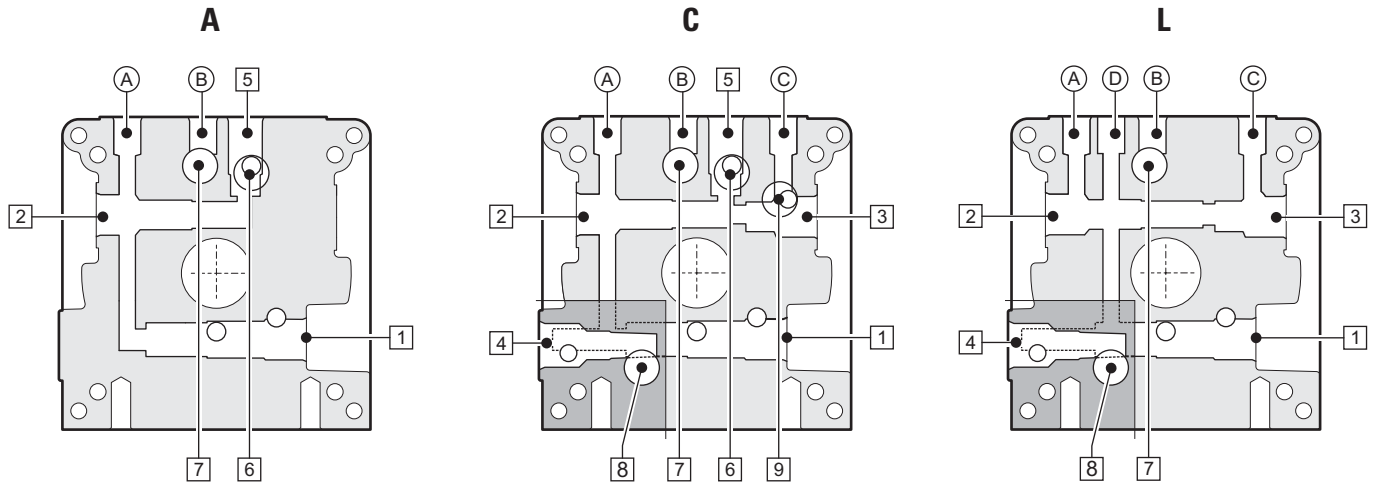
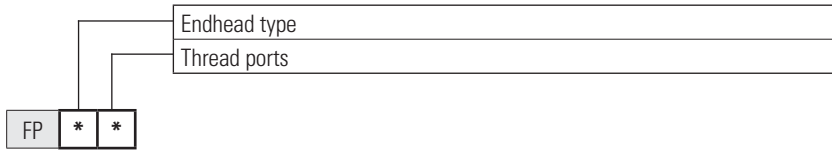

*** Endhead type**

| * | Ports | Peripheral | Return |
|----------|----------------------|--------------------------|----------------------|
| A | n. 2 (A - B) | n. 3 (1 - 2 - 5) | n. 2 (6 - 7) |
| C | n. 3 (A - B - C) | n. 5 (1 - 2 - 3 - 4 - 5) | n. 4 (6 - 7 - 8 - 9) |
| L | n. 4 (A - B - C - D) | n. 4 (1 - 2 - 3 - 4) | n. 2 (7 - 8) |
| E | n. 4 (A - B - C - D) | n. 3 (1 - 2 - 3) | n. 1 (9) |

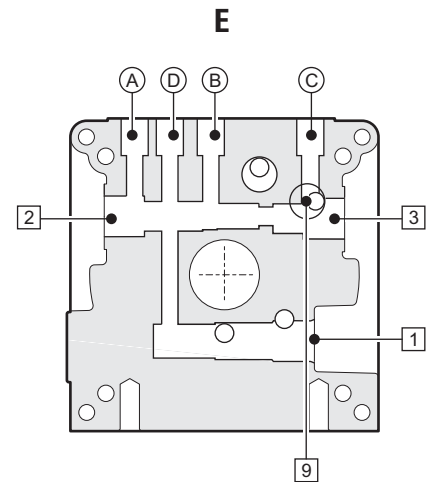

*** Thread ports**

| * | Ports thread | | Blocks interface |
|----------|--------------|-------|------------------|
| | G1/4" | G3/8" | |
| 0 | YES | | YES |
| 1 | | YES | NO |

| | Endhead codes | |
|------------|---------------|--------------|
| | G1/4" | G3/8" |
| FPA | 78013010.000 | 78013011.000 |
| FPC | 78013014.000 | 78013015.000 |
| FPL | 78013022.000 | |
| FPE | 78013016.000 | |

Sect. I - FPA Cavity 1

FPA
I

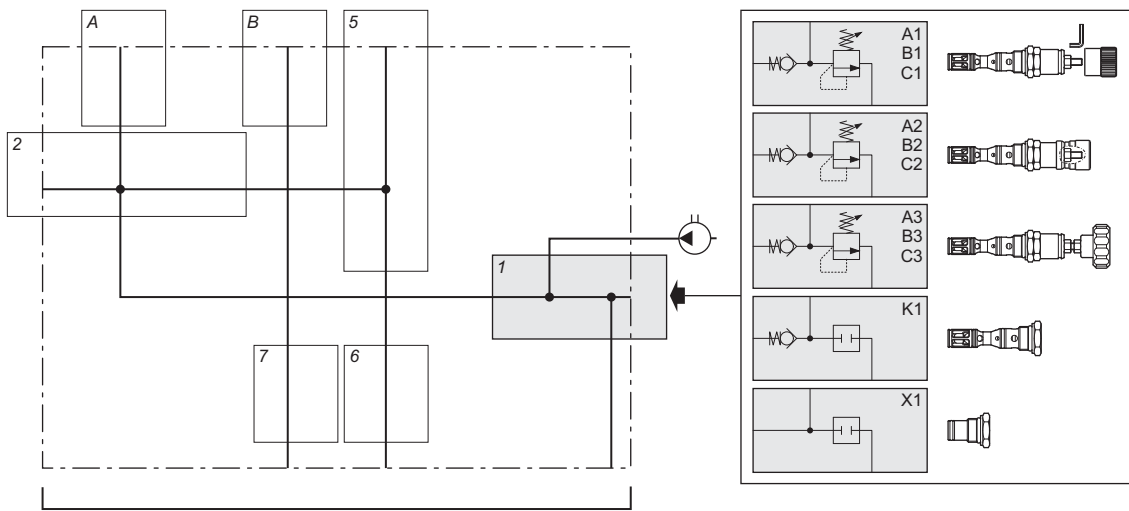
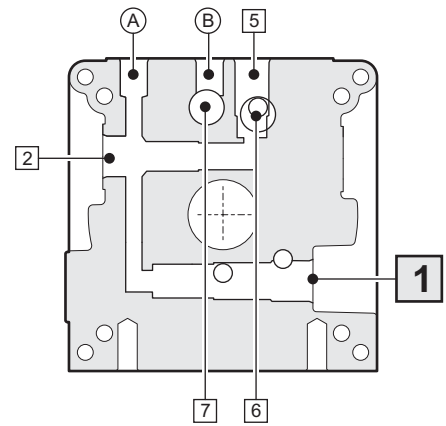
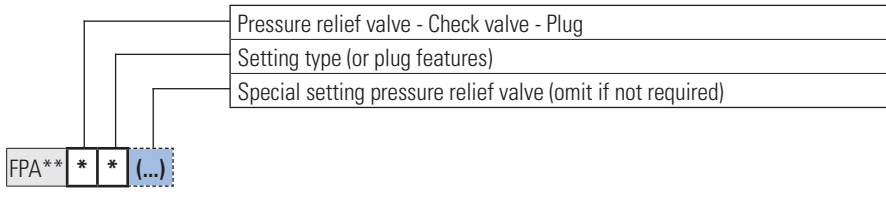

*** * (...)** *Pressure relief valve with check valve*

| * | * | Pressure (bar) | STD setting (bar) | (...) Special setting (bar) | Setting type | Code | Symbol | Drawing |
|----------|----------|----------------|-------------------|-----------------------------|---------------------------|--------------|--------|---------|
| A | 1 | 10 ÷ 60 | 50 | 10 ÷ 60 (5 to 5) | Detachable closing | CMPR04S01001 | | |
| | 2 | | | | Non removable closing (1) | CMPR04P01001 | | |
| | 3 | | | | Handwheel | CMPR04V01001 | | |
| B | 1 | > 60 ÷ 180 | 150 | 65 ÷ 180 (5 to 5) | Detachable closing | CMPR04S02001 | | |
| | 2 | | | | Non removable closing (1) | CMPR04P02001 | | |
| | 3 | | | | Handwheel | CMPR04V02001 | | |
| C | 1 | > 180 ÷ 320 | 210 | 190 ÷ 320 (10 to 10) | Detachable closing | CMPR04S03001 | | |
| | 2 | | | | Non removable closing (1) | CMPR04P03001 | | |
| | 3 | | | | Handwheel | CMPR04V03001 | | |

1 = Supplied assembled. Unassembled, see accessories page 89.

*** *** *Check valve and plug*

| * | * | Description | Code | Symbol | Drawing |
|----------|----------|--|------------|--------|---------|
| K | 1 | Check valve - Opening pressure 0.5 bar | CR10400001 | | |
| X | 1 | Plug | R78150100 | | |

Sect. II - FPA Cavity 2

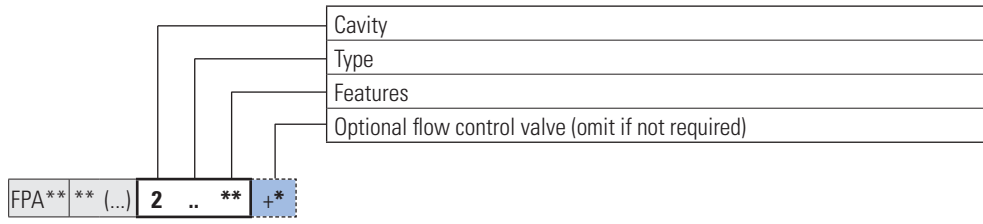

FPA

II

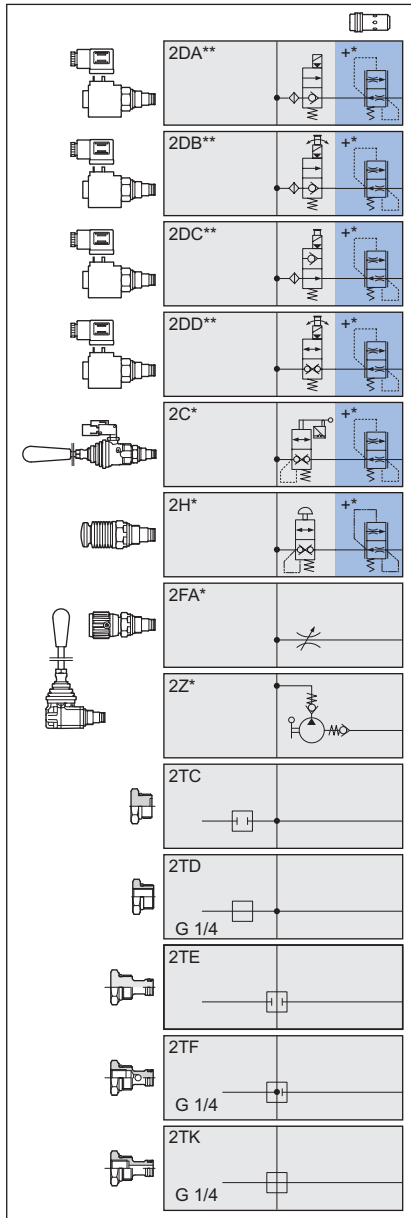

Optional flow control valves

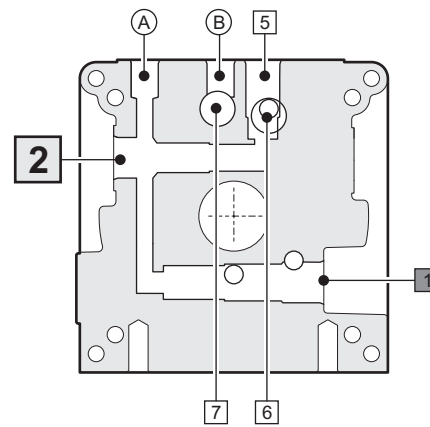
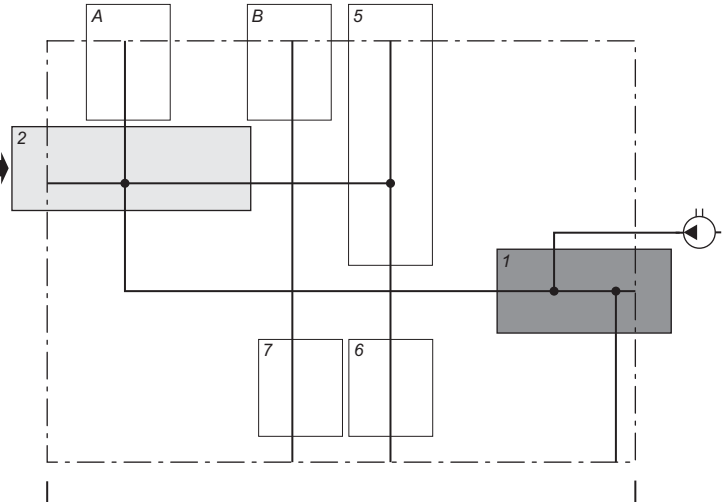

2 DA ** *Piloted solenoid valves normally closed, without emergency*

| ** | Description | Code (valve + connector) | Symbol | Drawing |
|----|-----------------------|-----------------------------|--------|---------|
| AA | Voltage 12 Vdc | CRP0418NCASL003 + V86050002 | | |
| AB | Voltage 24 Vdc | CRP0418NCASM003 + V86050002 | | |
| AC | Voltage 24 Vac 50 Hz | CRP0418NCASA003 + V86050002 | | |
| AD | Voltage 115 Vac 50 Hz | CRP0418NCASJ003 + V86050002 | | |
| AE | Voltage 230 Vac 50 Hz | CRP0418NCASI003 + V86050002 | | |

2 DB ** *Piloted solenoid valves normally closed, with emergency*

| ** | Description | Code (valve + connector) | Symbol | Drawing |
|----|-----------------------|-----------------------------|--------|---------|
| AA | Voltage 12 Vdc | CRP0418NCAEL003 + V86050002 | | |
| AB | Voltage 24 Vdc | CRP0418NCAEL003 + V86050002 | | |
| AC | Voltage 24 Vac 50 Hz | CRP0418NCAEA003 + V86050002 | | |
| AD | Voltage 115 Vac 50 Hz | CRP0418NCAEJ003 + V86050002 | | |
| AE | Voltage 230 Vac 50 Hz | CRP0418NCAEI003 + V86050002 | | |

2 DC ** *Piloted solenoid valves normally open, with emergency*

| ** | Description | Code (valve + connector) | Symbol | Drawing |
|----|--|-----------------------------|--------|---------|
| AA | Voltage 12 Vdc | CRP0418NAAEL003 + V86050002 | | |
| AB | Voltage 24 Vdc | CRP0418NAAEM003 + V86050002 | | |
| AC | Voltage 24 Vac 50/60 Hz (RAC with rectifier) | CRP0418NAAE2003 + V86200002 | | |
| AD | Voltage 115 Vac 50 - 120 Vac 60 Hz (RAC with rectifier) | CRP0418NAAEZ003 + V86200002 | | |
| AE | Voltage 230 Vac 50 - 240 Vac 60 Hz (RAC with rectifier) | CRP0418NAAEX003 + V86200002 | | |
| AF | Voltage 48 Vdc | CRP0418NAAEN003 + V86050002 | | |

2 DD ** *Direct operated solenoid valves normally closed, with emergency*

| ** | Description | Code (valve + connector) | Symbol | Drawing |
|----|----------------|-----------------------------|--------|---------|
| AA | Voltage 12 Vdc | CRD0418NCAEL002 + V86050002 | | |
| AB | Voltage 24 Vdc | CRD0418NCAEM002 + V86050002 | | |

2 C * *Lever operated valve*

| ** | Description | Code | Symbol | Drawing |
|----|---------------------|-----------|--------|---------|
| A | Without microswitch | CMF04L001 | | |
| B | With microswitch | CMF04M001 | | |

2 H * **Button operated valves**

| ** | Description | Code | Symbol | Drawing |
|----|---------------------|------------|--------|---------|
| A | Push-button control | CPE04P0001 | | |

2 .. ** **Flow control valves (1)**

| * | Flow | Code | Symbol | Drawing |
|----|------------|-----------|--------|---------|
| +B | 1.4 l/min | VSC040101 | | |
| +C | 2.3 l/min | VSC040201 | | |
| +E | 2.8 l/min | VSC040301 | | |
| +G | 4.3 l/min | VSC040401 | | |
| +J | 5.2 l/min | VSC040601 | | |
| +L | 6.5 l/min | VSC040801 | | |
| +N | 8.0 l/min | VSC041101 | | |
| +Q | 11.1 l/min | VSC041601 | | |

(1) The flow control valves can be installed with solenoid valves, with manual controls and with push-button valves.

2 FA * **Bidirectional flow control valves not compensated**

| * | Description | Code | Symbol | Drawing |
|---|-------------------------|------------|--------|---------|
| A | Screw adjustment | CSB04C0000 | | |
| B | Plastic knob adjustment | CSB04V0000 | | |

2 Z * **Hand pumps**

| * | Description | Code | Symbol | Drawing |
|---|-------------------|------------|--------|---------|
| A | Displacement 1 cc | CPM0410001 | | |
| B | Displacement 2 cc | CPM0420001 | | |

2 T * **Plugs and fittings**

| * | Description | Code | Symbol | Drawing |
|---|-------------------------------|-----------|--------|---------|
| C | Plug 3/4 16 UNF | R78150099 | | |
| D | Fitting 3/4 16 UNF - G1/4 | 20001700 | | |
| E | Long plug 3/4 16 UNF | 20003800 | | |
| F | Fitting 3/4 16 UNF - G1/4 | 20009400 | | |
| K | Fitting 3/4 16 UNF DIN - G1/4 | 20018000 | | |

FPA

II

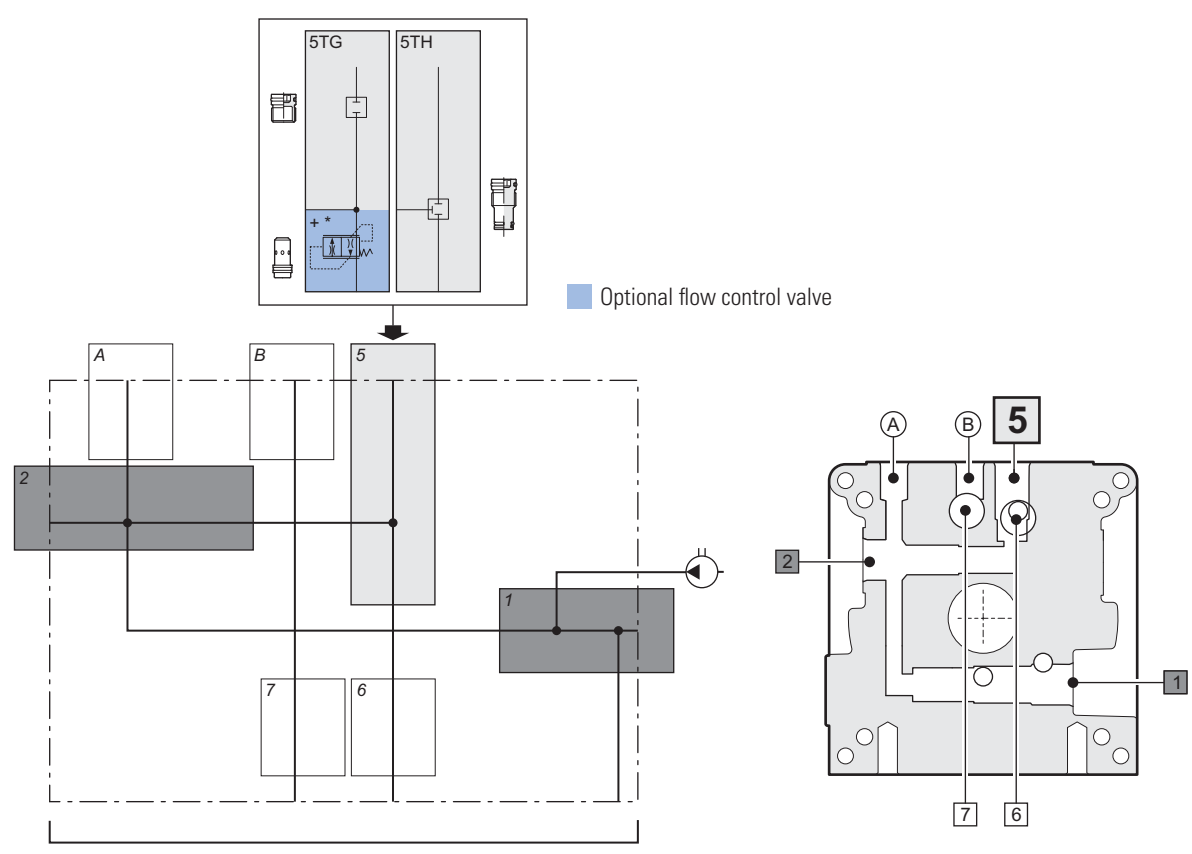
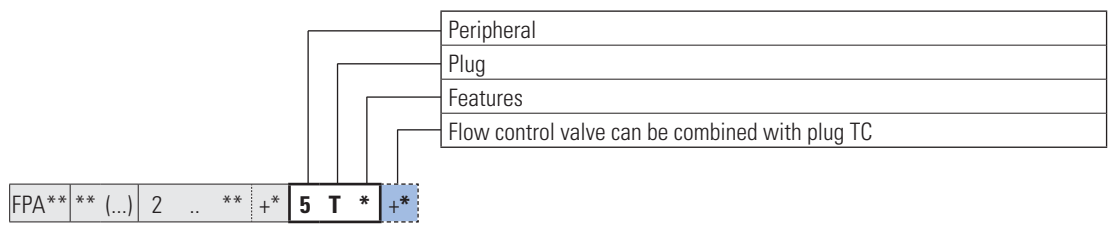

5 T * **Plugs**

| * | Description | Code | Symbol | Drawing |
|---|-------------------|-----------|--------|---------|
| G | Plug M16x1,5 (1) | R78150104 | | |
| H | Long plug M16x1,5 | R78150101 | | |

5 T G +* **Flow control valves (1)**

| * | Flow | Code | Symbol | Drawing |
|----|------------|-----------|--------|---------|
| +B | 1.4 l/min | VSC040101 | | |
| +C | 2.3 l/min | VSC040201 | | |
| +E | 2.8 l/min | VSC040301 | | |
| +G | 4.3 l/min | VSC040401 | | |
| +J | 5.2 l/min | VSC040601 | | |
| +L | 6.5 l/min | VSC040801 | | |
| +N | 8.0 l/min | VSC041101 | | |
| +Q | 11.1 l/min | VSC041601 | | |

(1) Flow control valves can be combined with plug TG.

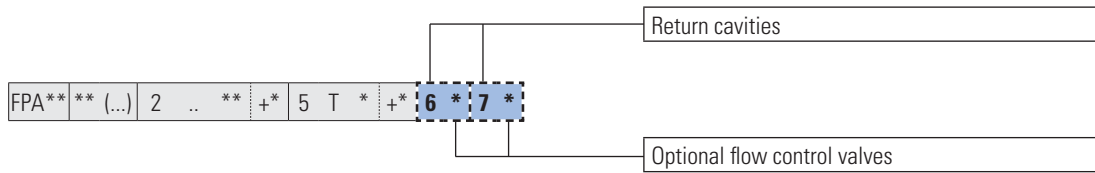

Return cavity, omit if not required flow control valves

FPA
II

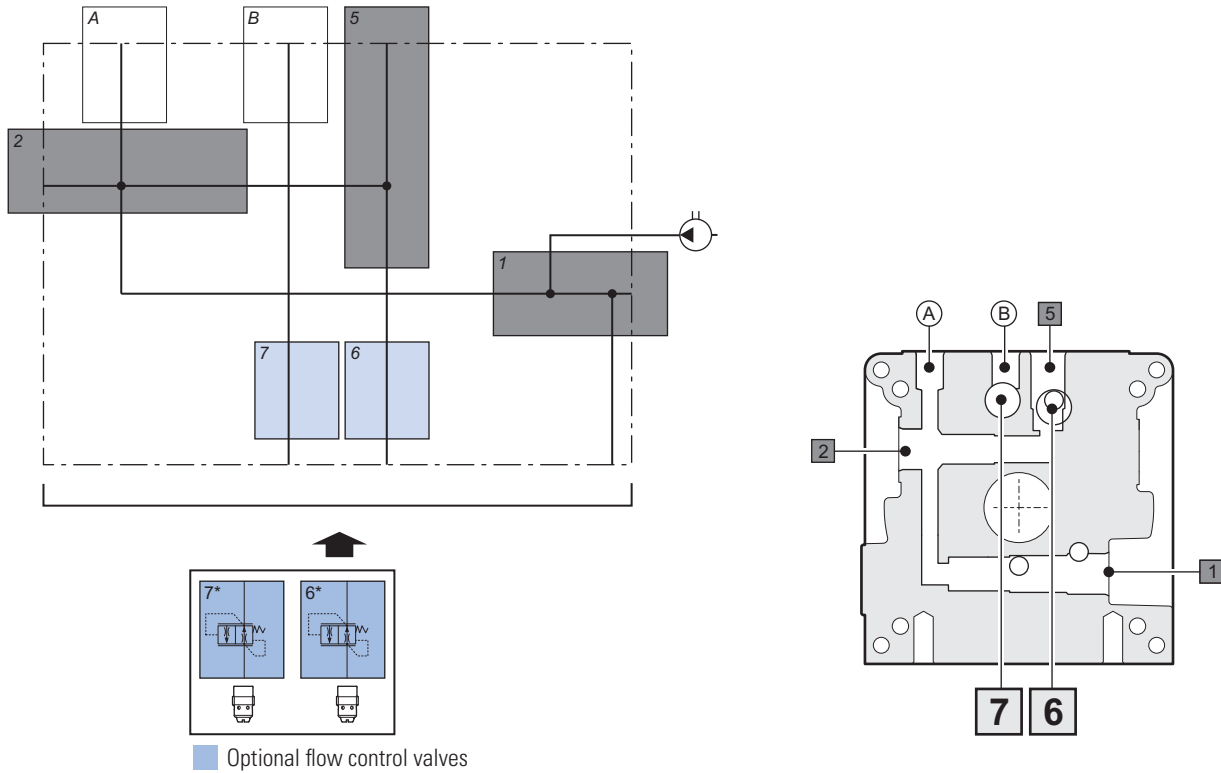

6* **7*** *Flow control valves for return cavities "6-7"*

| * A B C E G K N Q U V | Nominal flow at 120 bar | Code | Symbol | Drawing |
|---|-------------------------|-------------|--------|---------|
| A | 0.7 l/min | VSC06100002 | | |
| B | 1.1 l/min | VSC06120002 | | |
| C | 2.1 l/min | VSC06130002 | | |
| E | 3.2 l/min | VSC06150002 | | |
| G | 4.7 l/min | VSC06190002 | | |
| K | 6.3 l/min | VSC06220002 | | |
| N | 7.5 l/min | VSC06240002 | | |
| Q | 10.0 l/min | VSC06280002 | | |
| U | 13.2 l/min | VSC06330002 | | |
| V | 15.7 l/min | VSC06350002 | | |

Possible combinations plugs on ports
End section II

FPA** ** (...) 2 .. ** +* 5 T * +* 6 * 7 * -** -

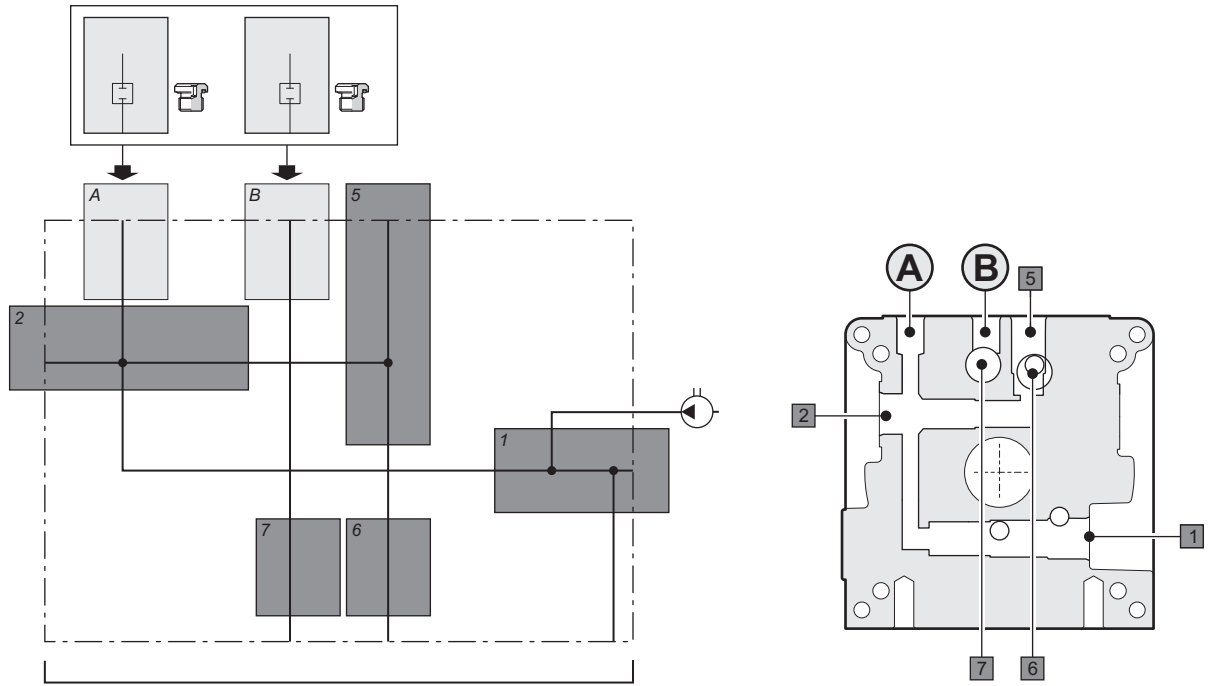

-** Possible combinations plugs on ports A-B

| -** | A | B |
|-----|---|---|
| -00 | ↑ | ↑ |
| -02 | ⊗ | ↑ |
| -03 | ↑ | ⊗ |
| -06 | ⊗ | ⊗ |

Symbols description

| Type | Description | Thread | Code | Symbol | Drawing |
|------|-----------------------|--------|-----------------------------|--------|---------|
| ⊗ | Port closed with plug | G 1/4" | 20024000 | | |
| | | G 3/8" | Q26630006 (plug with OR) | | |
| ↑ | Open port | | — | — | — |

Combination -00 to use with the standard blocks (page 85)

Sect. I - FPC Cavity 1

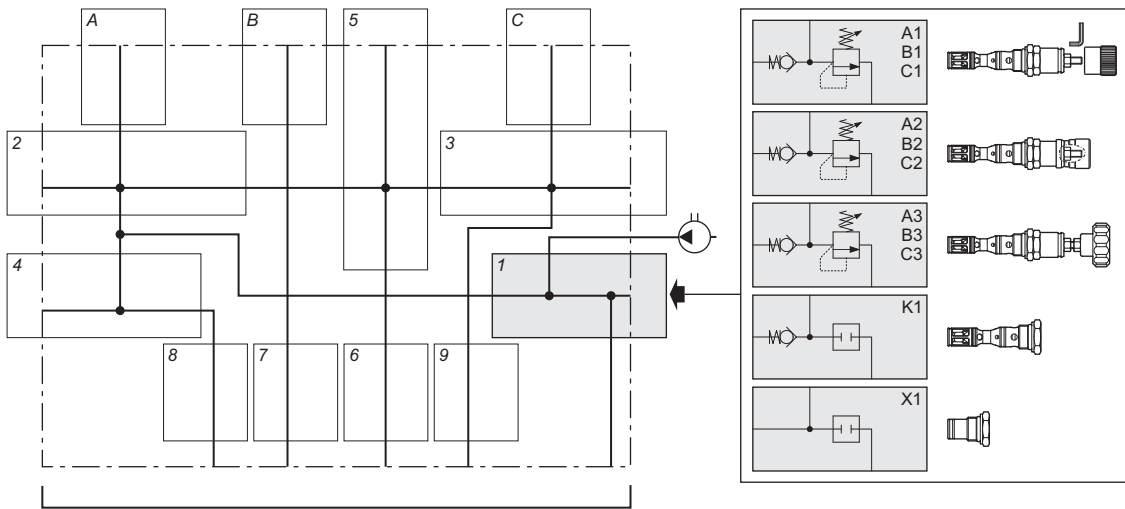
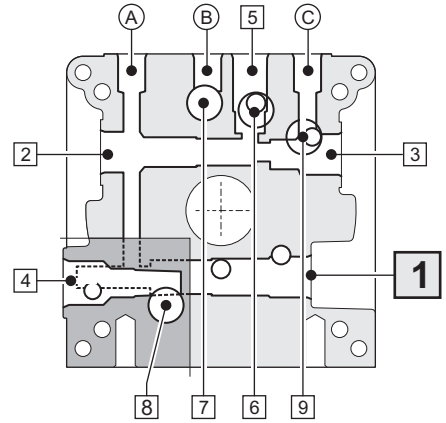
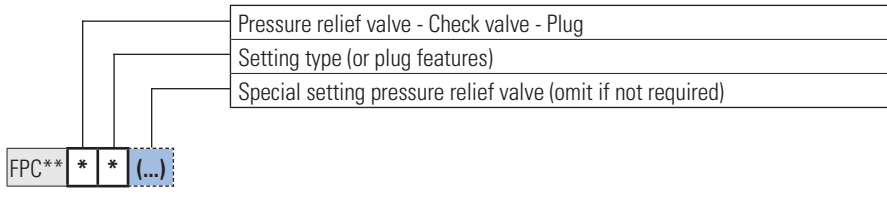

FPC
I

*** * (...)** **Pressure relief valve with check valve**

| * | * | Pressure (bar) | STD setting (bar) | (...) Special setting (bar) | Setting type | Code | Symbol | Drawing |
|----------|----------|----------------|-------------------|-----------------------------|---------------------------|--------------|--------|---------|
| A | 1 | 10 ÷ 60 | 50 | 10 ÷ 60 (5 to 5) | Detachable closing | CMPR04S01001 | | |
| | 2 | | | | Non removable closing (1) | CMPR04P01001 | | |
| | 3 | | | | Handwheel | CMPR04V01001 | | |
| B | 1 | > 60 ÷ 180 | 150 | 65 ÷ 180 (5 to 5) | Detachable closing | CMPR04S02001 | | |
| | 2 | | | | Non removable closing (1) | CMPR04P02001 | | |
| | 3 | | | | Handwheel | CMPR04V02001 | | |
| C | 1 | > 180 ÷ 320 | 210 | 190 ÷ 320 (10 to 10) | Detachable closing | CMPR04S03001 | | |
| | 2 | | | | Non removable closing (1) | CMPR04P03001 | | |
| | 3 | | | | Handwheel | CMPR04V03001 | | |

1 = Supplied assembled. Unassembled, see accessories page 89.

*** * Check valve and plug**

| * | * | Description | Code | Symbol | Drawing |
|----------|----------|--|------------|--------|---------|
| K | 1 | Check valve - Opening pressure 0.5 bar | CR10400001 | | |
| X | 1 | Plug | R78150100 | | |

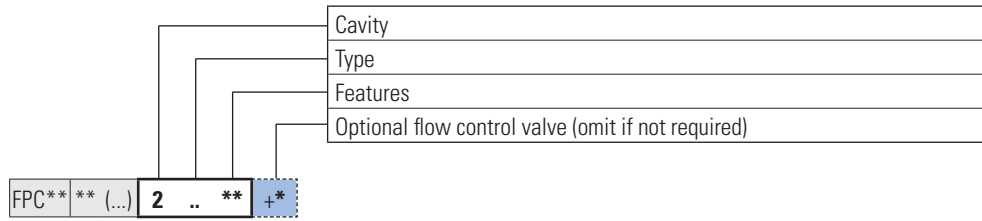

FPC
II

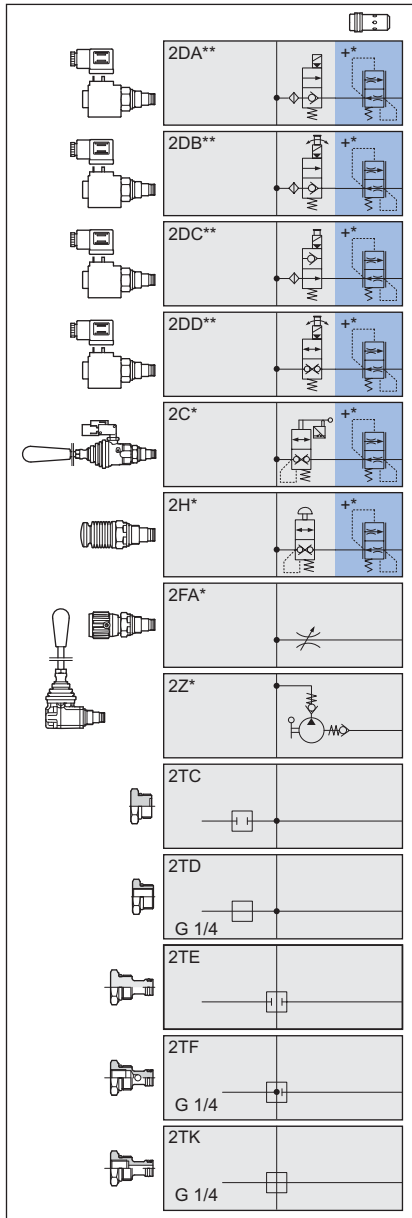

Optional flow control valves

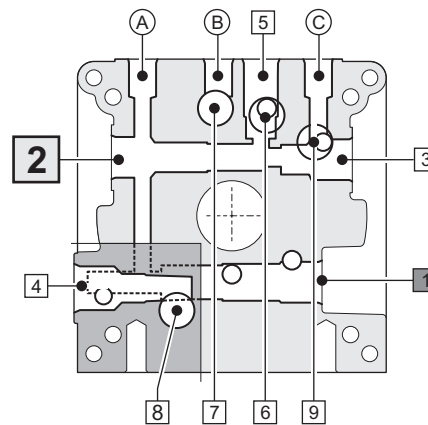
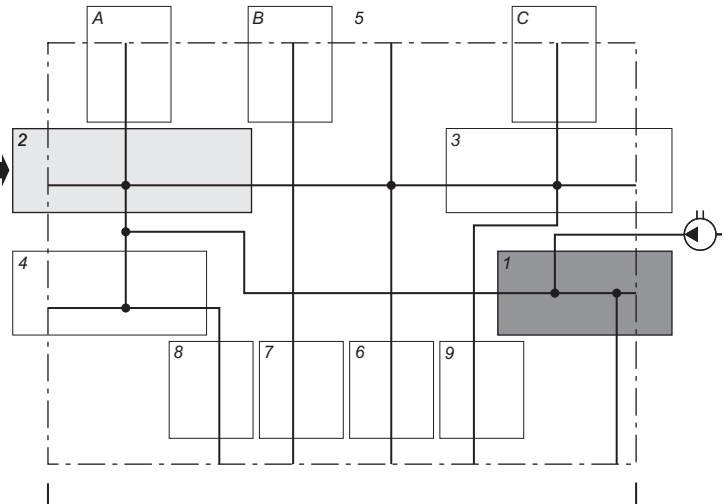

2 DA ** *Piloted solenoid valves normally closed, without emergency*

| ** | Description | Code (valve + connector) | Symbol | Drawing |
|----|-----------------------|-----------------------------|--------|---------|
| AA | Voltage 12 Vdc | CRP0418NCASL003 + V86050002 | | |
| AB | Voltage 24 Vdc | CRP0418NCASM003 + V86050002 | | |
| AC | Voltage 24 Vac 50 Hz | CRP0418NCASA003 + V86050002 | | |
| AD | Voltage 115 Vac 50 Hz | CRP0418NCASJ003 + V86050002 | | |
| AE | Voltage 230 Vac 50 Hz | CRP0418NCASI003 + V86050002 | | |

2 DB ** *Piloted solenoid valves normally closed, with emergency*

| ** | Description | Code (valve + connector) | Symbol | Drawing |
|----|-----------------------|-----------------------------|--------|---------|
| AA | Voltage 12 Vdc | CRP0418NCAEL003 + V86050002 | | |
| AB | Voltage 24 Vdc | CRP0418NCAEL003 + V86050002 | | |
| AC | Voltage 24 Vac 50 Hz | CRP0418NCAEA003 + V86050002 | | |
| AD | Voltage 115 Vac 50 Hz | CRP0418NCAEJ003 + V86050002 | | |
| AE | Voltage 230 Vac 50 Hz | CRP0418NCAEI003 + V86050002 | | |

2 DC ** *Piloted solenoid valves normally open, with emergency*

| ** | Description | Code (valve + connector) | Symbol | Drawing |
|----|--|-----------------------------|--------|---------|
| AA | Voltage 12 Vdc | CRP0418NAAEL003 + V86050002 | | |
| AB | Voltage 24 Vdc | CRP0418NAAEM003 + V86050002 | | |
| AC | Voltage 24 Vac 50/60 Hz (RAC with rectifier) | CRP0418NAAE2003 + V86200002 | | |
| AD | Voltage 115 Vac 50 - 120 Vac 60 Hz (RAC with rectifier) | CRP0418NAAEZ003 + V86200002 | | |
| AE | Voltage 230 Vac 50 - 240 Vac 60 Hz (RAC with rectifier) | CRP0418NAAEX003 + V86200002 | | |
| AF | Voltage 48 Vdc | CRP0418NAAEN003 + V86050002 | | |

2 DD ** *Direct operated solenoid valve normally closed, with emergency*

| ** | Description | Code (valve + connector) | Symbol | Drawing |
|----|----------------|-----------------------------|--------|---------|
| AA | Voltage 12 Vdc | CRD0418NCAEL002 + V86050002 | | |
| AB | Voltage 24 Vdc | CRD0418NCAEM002 + V86050002 | | |

2 C * *Lever operated valve*

| ** | Description | Code | Symbol | Drawing |
|----|---------------------|-----------|--------|---------|
| A | Without microswitch | CMF04L001 | | |
| B | With microswitch | CMF04M001 | | |

FPC
II

2 H * **Button operated valves**

| ** | Description | Code | Symbol | Drawing |
|----|---------------------|-------------|--------|---------|
| A | Push-button control | CPE04P000.1 | | |

2 .. ** **Flow control valves (1)**

| * | Flow | Code | Symbol | Drawing |
|----|------------|-----------|--------|---------|
| +B | 1.4 l/min | VSC040101 | | |
| +C | 2.3 l/min | VSC040201 | | |
| +E | 2.8 l/min | VSC040301 | | |
| +G | 4.3 l/min | VSC040401 | | |
| +J | 5.2 l/min | VSC040601 | | |
| +L | 6.5 l/min | VSC040801 | | |
| +N | 8.0 l/min | VSC041101 | | |
| +Q | 11.1 l/min | VSC041601 | | |

(1) The flow control valves can be installed with solenoid valves, with manual controls and with push-button valves.

2 FA * **Bidirectional flow control valves not compensated**

| * | Description | Code | Symbol | Drawing |
|---|-------------------------|------------|--------|---------|
| A | Screw adjustment | CSB04C0000 | | |
| B | Plastic knob adjustment | CSB04V0000 | | |

2 Z * **Hand pumps**

| * | Description | Code | Symbol | Drawing |
|---|-------------------|------------|--------|---------|
| A | Displacement 1 cc | CPM0410001 | | |
| B | Displacement 2 cc | CPM0420001 | | |

2 T * **Plugs and fittings**

| * | Description | Code | Symbol | Drawing |
|---|-------------------------------|-----------|--------|---------|
| C | Plug 3/4 16 UNF | R78150099 | | |
| D | Fitting 3/4 16 UNF - G1/4 | 20001700 | | |
| E | Long plug 3/4 16 UNF | 20003800 | | |
| F | Fitting 3/4 16 UNF - G1/4 | 20009400 | | |
| K | Fitting 3/4 16 UNF DIN - G1/4 | 20018000 | | |

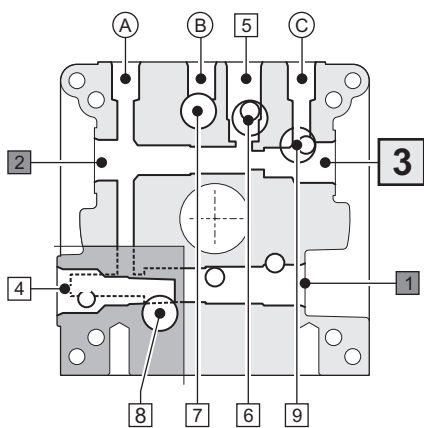
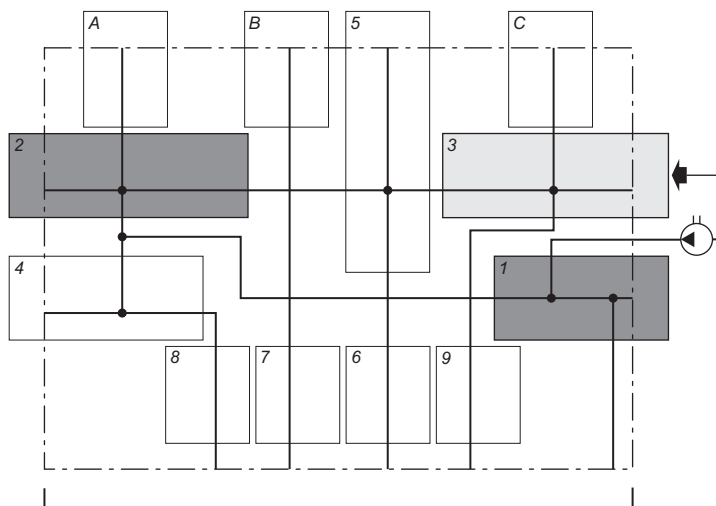
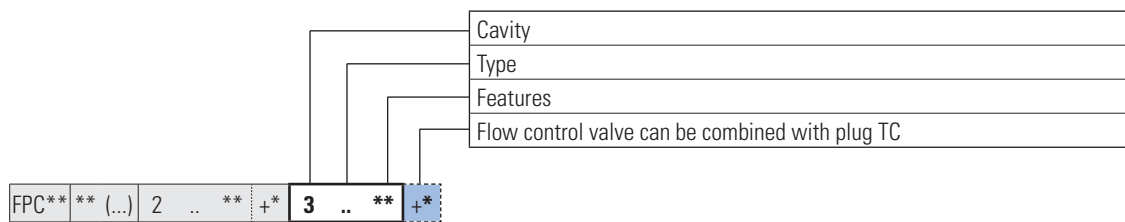

| | | |
|--------|--|--|
| 3DD* | | |
| 3H* | | |
| 3FA* | | |
| 3FB* | | |
| 3A** | | |
| 3B* | | |
| +* 3TC | | |
| 3TD | | |
| 3TE | | |
| 3TF | | |
| 3TK | | |

 Optional flow control valves

FPC

II

3 DD ** *Piloted solenoid valves normally closed, with emergency*

| ** | Description | Code (valve + connector) | Symbol | Drawing |
|----|----------------|-----------------------------|--------|---------|
| AA | Voltage 12 Vdc | CRD0418NCAEL002 + V86050002 | | |
| AB | Voltage 24 Vdc | CRD0418NCAEM002 + V86050002 | | |

3 H * *Button operated valves*

| ** | Description | Code | Symbol | Drawing |
|----|---------------------|-------------|--------|---------|
| A | Push-button control | CPE04P000.1 | | |

3 FA * *Bidirectional flow control valves not compensated*

| * | Description | Code | Symbol | Drawing |
|---|-------------------------|------------|--------|---------|
| A | Screw adjustment | CSB04C0000 | | |
| B | Plastic knob adjustment | CSB04V0000 | | |



3 FB * *Unidirectional flow control valves compensated*

| * | Description | Code | Symbol | Drawing |
|---|-------------------------|------------|--------|---------|
| A | Screw adjustment | CSC04C0000 | | |
| B | Plastic knob adjustment | CSC04V0000 | | |











3 A ** *Pressure relief valves*

| ** | Description | Regolazione (bar) | Code | Symbol | Drawing | |
|----|--------------------------|-------------------|------------|--------|---------|--|
| AA | Short screw adjustment | Min 10 - Max 70 | CMP04E1001 | | | |
| AB | | Min 80 - Max 140 | CMP04E2001 | | | |
| AC | | Min 100 - Max 330 | CMP04E3001 | | | |
| BA | Screw adjustment | Min 10 - Max 70 | CMP04C1001 | | | |
| BB | | Min 80 - Max 140 | CMP04C2001 | | | |
| BC | | Min 100 - Max 330 | CMP04C3001 | | | |
| CA | Plastic knob adjustment | Min 10 - Max 70 | CMP04V1001 | | | |
| CB | | Min 80 - Max 140 | CMP04V2001 | | | |
| CC | | Min 100 - Max 330 | CMP04V3001 | | | |
| DA | Short screw + sealed cap | Min 10 - Max 70 | CMP04P1001 | | | |
| DB | | Min 80 - Max 140 | CMP04P2001 | | | |
| DC | | Min 100 - Max 330 | CMP04P3001 | | | |



3 B * One-way check valves

| * | Opening pressure | Code | Symbol | Drawing |
|---|--------------------|------------|---|---|
| A | 0,7 bar (Standard) | CRU0400002 |  |  |
| B | 4,5 bar | CRU0404002 | | |
| C | 10 bar | CRU0410002 | | |

3 T * Plugs and fittings

| * | Description | Code | Symbol | Drawing |
|---|-------------------------------|-----------|---|---|
| C | Plug 3/4 16 UNF (1) | R78150099 |  |  |
| D | Fitting 3/4 16 UNF - G1/4 | 20001700 |  |  |
| E | Long plug 3/4 16 UNF | 20003800 |  |  |
| F | Fitting 3/4 16 UNF - G1/4 | 20009400 |  |  |
| K | Fitting 3/4 16 UNF - DIN G1/4 | 20018000 |  |  |

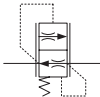
3 T C +* Flow control valves (1)

| * | Flow | Code | Symbol | Drawing |
|----|------------|-----------|---|---|
| +B | 1.4 l/min | VSC040101 |  |  |
| +C | 2.3 l/min | VSC040201 | | |
| +E | 2.8 l/min | VSC040301 | | |
| +G | 4.3 l/min | VSC040401 | | |
| +J | 5.2 l/min | VSC040601 | | |
| +L | 6.5 l/min | VSC040801 | | |
| +N | 8.0 l/min | VSC041101 | | |
| +Q | 11.1 l/min | VSC041601 | | |

(1) | The flow control valves can be installed with the plug TC

| |
|----------|
| Cavity |
| Type |
| Features |

FPC** ** (...)

| | | |
|------------|------------|----------------|
| 2 .. ** +* | 3 .. ** +* | 4 .. ** |
|------------|------------|----------------|

FPC
II

| | | |
|--|-------|-------|
| | 4DA** | |
| | 4DB** | |
| | 4DC** | |
| | 4DD** | |
| | 4C* | |
| | 4H* | |
| | 4FA* | |
| | 4Z* | |
| | 4TE | |
| | 4TF | |
| | G 1/4 | |
| | 4TK | |
| | | G 1/4 |

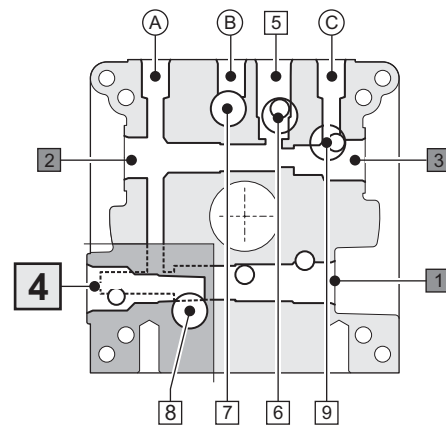
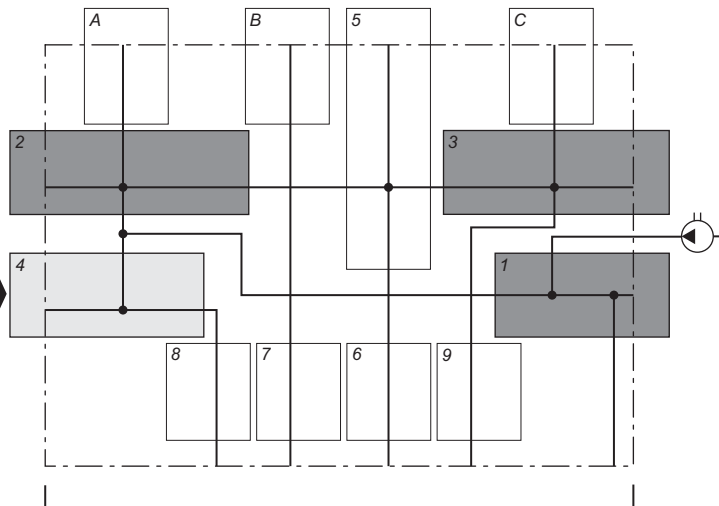

4 DA ** *Piloted solenoid valves normally closed, without emergency*

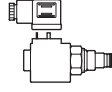
| ** | Description | Code (valve + connector) | Symbol | Drawing |
|----|-----------------------|-----------------------------|---|---|
| AA | Voltage 12 Vdc | CRP0418NCASL003 + V86050002 |  |  |
| AB | Voltage 24 Vdc | CRP0418NCASM003 + V86050002 | | |
| AC | Voltage 24 Vac 50 Hz | CRP0418NCASA003 + V86050002 | | |
| AD | Voltage 115 Vac 50 Hz | CRP0418NCASJ003 + V86050002 | | |
| AE | Voltage 230 Vac 50 Hz | CRP0418NCASI003 + V86050002 | | |

4 DB ** *Piloted solenoid valves normally closed, with emergency*

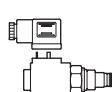
| ** | Description | Code (valve + connector) | Symbol | Drawing |
|----|-----------------------|-----------------------------|---|---|
| AA | Voltage 12 Vdc | CRP0418NCAEL003 + V86050002 |  |  |
| AB | Voltage 24 Vdc | CRP0418NCAEM003 + V86050002 | | |
| AC | Voltage 24 Vac 50 Hz | CRP0418NCAEA003 + V86050002 | | |
| AD | Voltage 115 Vac 50 Hz | CRP0418NCAEJ003 + V86050002 | | |
| AE | Voltage 230 Vac 50 Hz | CRP0418NCAEI003 + V86050002 | | |

4 DC ** *Piloted solenoid valves normally open, with emergency*

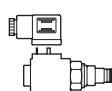
| ** | Description | Code (valve + connector) | Symbol | Drawing |
|----|---|-----------------------------|---|---|
| AA | Voltage 12 Vdc | CRP0418NAAEL003 + V86050002 |  |  |
| AB | Voltage 24 Vdc | CRP0418NAAEM003 + V86050002 | | |
| AC | Tensione 24 Vac 50/60 Hz (RAC with rectifier) | CRP0418NAAE2003 + V86200002 | | |
| AD | Voltage 115 Vac 50 - 120 Vac 60 Hz (RAC with rectifier) | CRP0418NAAEZ003 + V86200002 | | |
| AE | Voltage 230 Vac 50 - 240 Vac 60 Hz (RAC with rectifier) | CRP0418NAAEX003 + V86200002 | | |
| AF | Tensione 48 Vdc | CRP0418NAAEN003 + V86050002 | | |

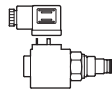

4 DD ** *Direct operated solenoid valve normally closed, with emergency*

| ** | Description | Code (valve + connector) | Symbol | Drawing |
|----|----------------|-----------------------------|---|---|
| AA | Voltage 12 Vdc | CRD0418NCAEL002 + V86050002 |  |  |
| AB | Voltage 24 Vdc | CRD0418NCAEM002 + V86050002 | | |



FPC

II

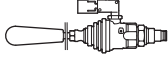

4 C * *Lever operated valve*

| ** | Description | Code | Symbol | Drawing |
|----|---------------------|------------|---|---|
| A | Without microswitch | CMF04L0001 |  |  |
| B | With microswitch | CMF04M0001 |  |  |



4 H * *Button operated valves*

| ** | Description | Code | Symbol | Drawing |
|----|---------------------|-------------|---|---|
| A | Push-button control | CPE04P000.1 |  |  |







4 FA * *Bidirectional flow control valves not compensated*

| * | Description | Code | Symbol | Drawing |
|---|-------------------------|------------|---|---|
| A | Screw adjustment | CSB04C0000 |  |  |
| B | Plastic knob adjustment | CSB04V0000 | |  |

4 Z * *Hand pumps*

| * | Description | Code | Symbol | Drawing |
|---|-------------------|------------|---|---|
| A | Displacement 1 cc | CPM0410001 |  |  |
| B | Displacement 2 cc | CPM0420001 | |  |

4 T * *Plugs and fittings*

| * | Description | Code | Symbol | Drawing |
|---|-------------------------------|----------|---|---|
| E | Long plug 3/4 16 UNF | 20003800 |  |  |
| F | Fitting 3/4 16 UNF - G1/4 | 20009400 |  |  |
| K | Fitting 3/4 16 UNF DIN - G1/4 | 20018000 |  |  |

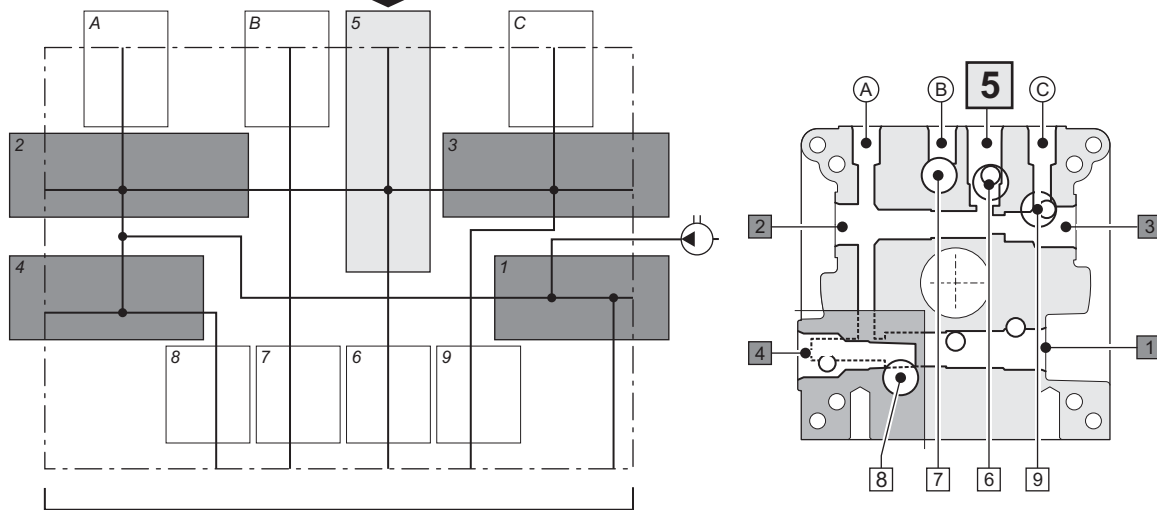
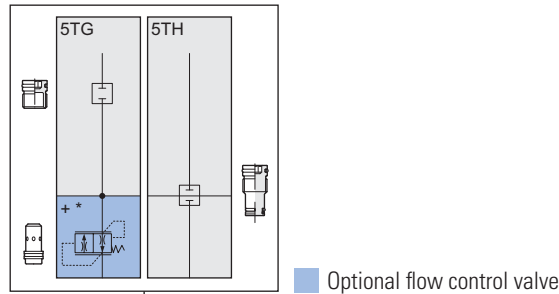
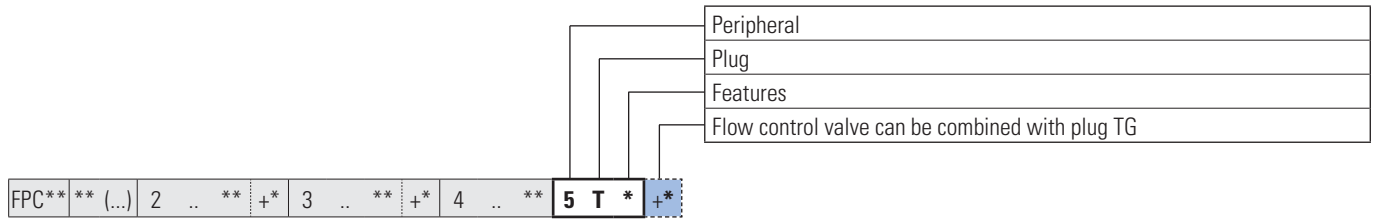

FPC
 II

5 T * **Plugs**

| * Description | Code | Symbol | Drawing |
|----------------------------|-----------|--------|---------|
| G Plug M16x1,5 (1) | R78150104 | | |
| H Long plug M16x1,5 | R78150101 | | |

5 T G **Flow control valves (1)**

| * Flow | Code | Symbol | Drawing |
|----------------------|-----------|--------|---------|
| +B 1.4 l/min | VSC040101 | | |
| +C 2.3 l/min | VSC040201 | | |
| +E 2.8 l/min | VSC040301 | | |
| +G 4.3 l/min | VSC040401 | | |
| +J 5.2 l/min | VSC040601 | | |
| +L 6.5 l/min | VSC040801 | | |
| +N 8.0 l/min | VSC041101 | | |
| +Q 11.1 l/min | VSC041601 | | |

(1) The flow control valves can be installed with the plug TG

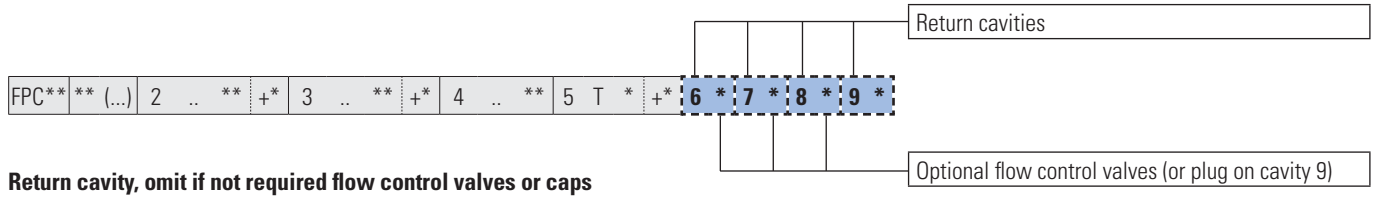

Return cavity, omit if not required flow control valves or caps

Optional flow control valves (or plug on cavity 9)

FPC
II

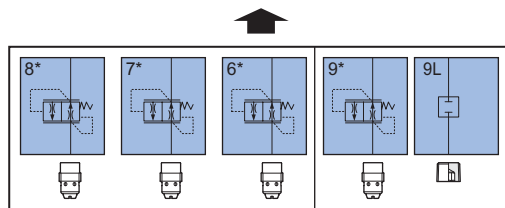
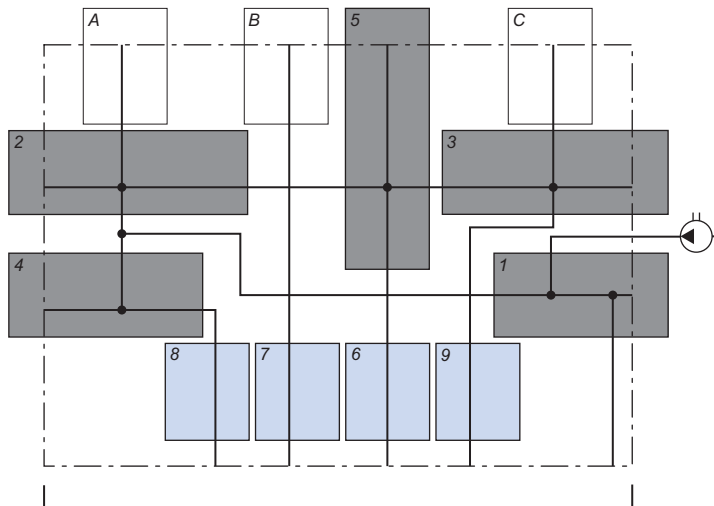

Optional flow control valves or plug on cavity 9

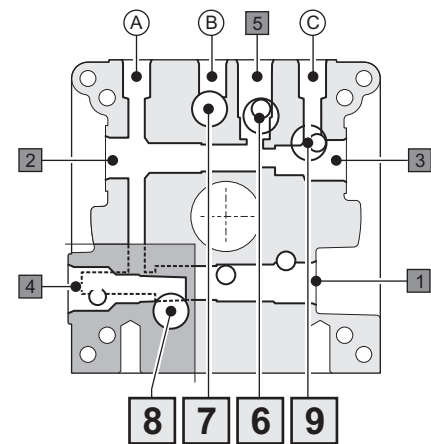

6* Flow control valves for return cavities "6-7-8-9"

| * 6 7 8 9 | | Nominal flow at 120 bar | Code | Symbol | Drawing |
|-----------------------|------------|-------------------------|------|--------|---------|
| A | 0.7 l/min | VSC06100002 | | | |
| B | 1.1 l/min | VSC06120002 | | | |
| C | 2.1 l/min | VSC06130002 | | | |
| E | 3.2 l/min | VSC06150002 | | | |
| G | 4.7 l/min | VSC06190002 | | | |
| K | 6.3 l/min | VSC06220002 | | | |
| N | 7.5 l/min | VSC06240002 | | | |
| Q | 10.0 l/min | VSC06280002 | | | |
| U | 13.2 l/min | VSC06330002 | | | |
| V | 15.7 l/min | VSC06350002 | | | |

9T* Plugs for return cavity "9"

| * 9T | Description | Code | Symbol | Drawing |
|---------|-------------------|-----------|--------|---------|
| M | Conical plug G3/8 | Q26620350 | | |

Possible combinations plugs on ports
End section II

FPC** ** (...) 2 .. ** +* 3 .. ** +* 4 .. ** 5 T * +* 6 * 7 * 8 * 9 * **-**** -

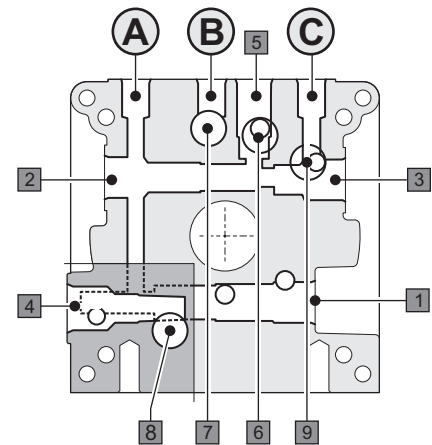
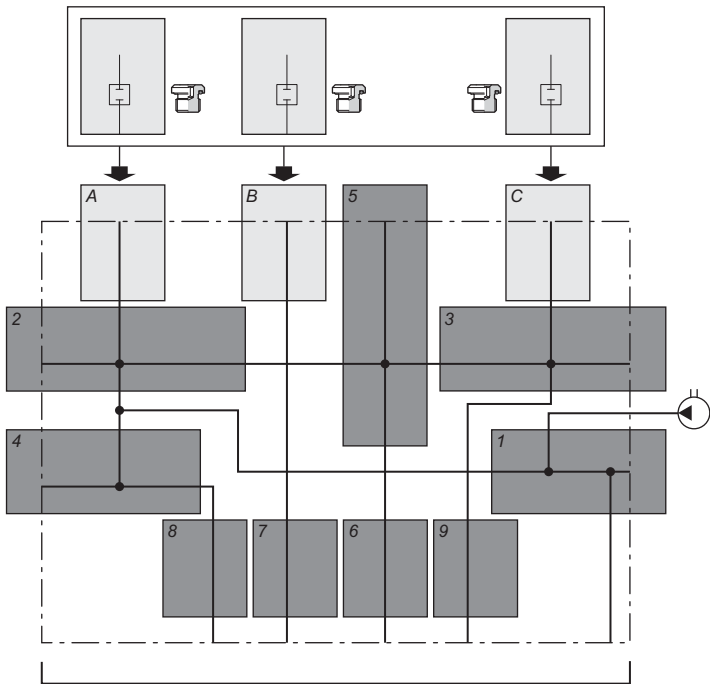

FPC
II

-** Possible combinations plugs on ports A-B-C

| -** | A | B | C |
|-----|---|---|---|
| -00 | ↑ | ↑ | ⊗ |
| -01 | ↑ | ↑ | ↑ |
| -02 | ⊗ | ↑ | ↑ |
| -03 | ↑ | ⊗ | ↑ |
| -05 | ↑ | ⊗ | ⊗ |
| -06 | ⊗ | ⊗ | ↑ |
| -07 | ⊗ | ↑ | ⊗ |
| -08 | ⊗ | ⊗ | ⊗ |

Symbols description

| Type | Description | Thread | Code | Symbol | Drawing |
|------|-----------------------|--------|-----------------------------|--------|---------|
| ⊗ | Port closed with plug | G 1/4" | 20024000 | | |
| | | G 3/8" | Q26630006 (plug with OR) | | |
| ↑ | Open port | | — | — | — |

Combination -00 to use with the standard blocks (page 85)

Sect. I - FPL Cavity 1

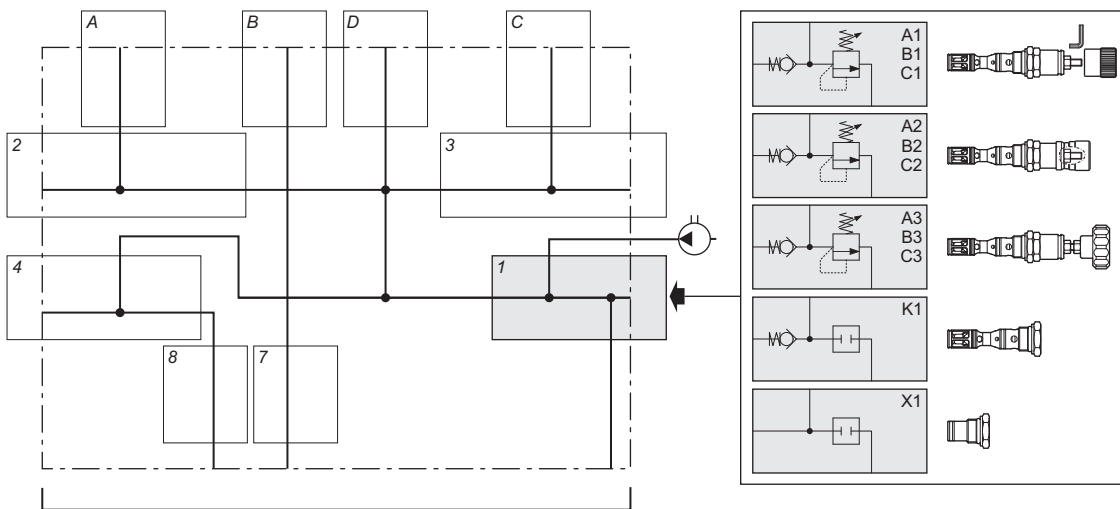
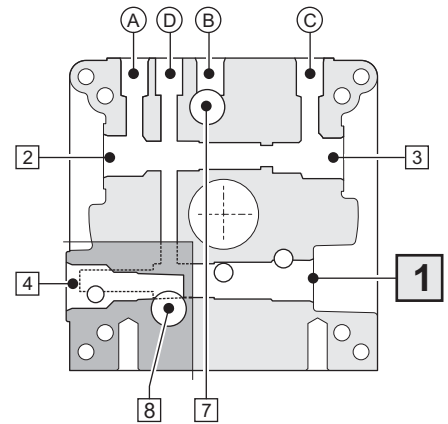
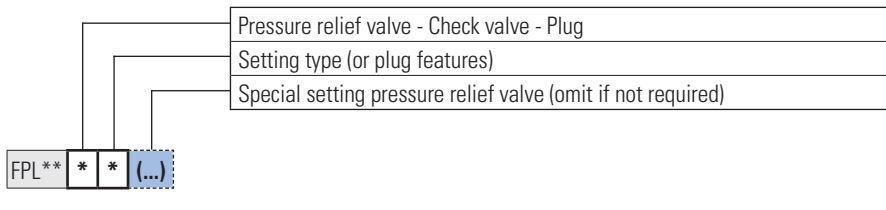

FPL
I

* * (...) Pressure relief valve with check valve

| * | * | Pressure (bar) | STD setting (bar) | (...) Special setting (bar) | Setting type | Code | Symbol | Drawing |
|----------|----------|----------------|-------------------|-----------------------------|---------------------------|--------------|--------|---------|
| A | 1 | 10 ÷ 60 | 50 | 10 ÷ 60 (5 to 5) | Detachable closing | CMPR04S01001 | | |
| | 2 | | | | Non removable closing (1) | CMPR04P01001 | | |
| | 3 | | | | Handwheel | CMPR04V01001 | | |
| B | 1 | > 60 ÷ 180 | 150 | 65 ÷ 180 (5 to 5) | Detachable closing | CMPR04S02001 | | |
| | 2 | | | | Non removable closing (1) | CMPR04P02001 | | |
| | 3 | | | | Handwheel | CMPR04V02001 | | |
| C | 1 | > 180 ÷ 320 | 210 | 190 ÷ 320 (10 to 10) | Detachable closing | CMPR04S03001 | | |
| | 2 | | | | Non removable closing (1) | CMPR04P03001 | | |
| | 3 | | | | Handwheel | CMPR04V03001 | | |

1 = Supplied assembled. Unassembled, see accessories page 89.

* * Check valve and plug

| * | * | Description | Code | Symbol | Drawing |
|----------|----------|--|------------|--------|---------|
| K | 1 | Check valve - Opening pressure 0.5 bar | CR10400001 | | |
| X | 1 | Plug | R78150100 | | |

Sect. II - FPL Cavity 2

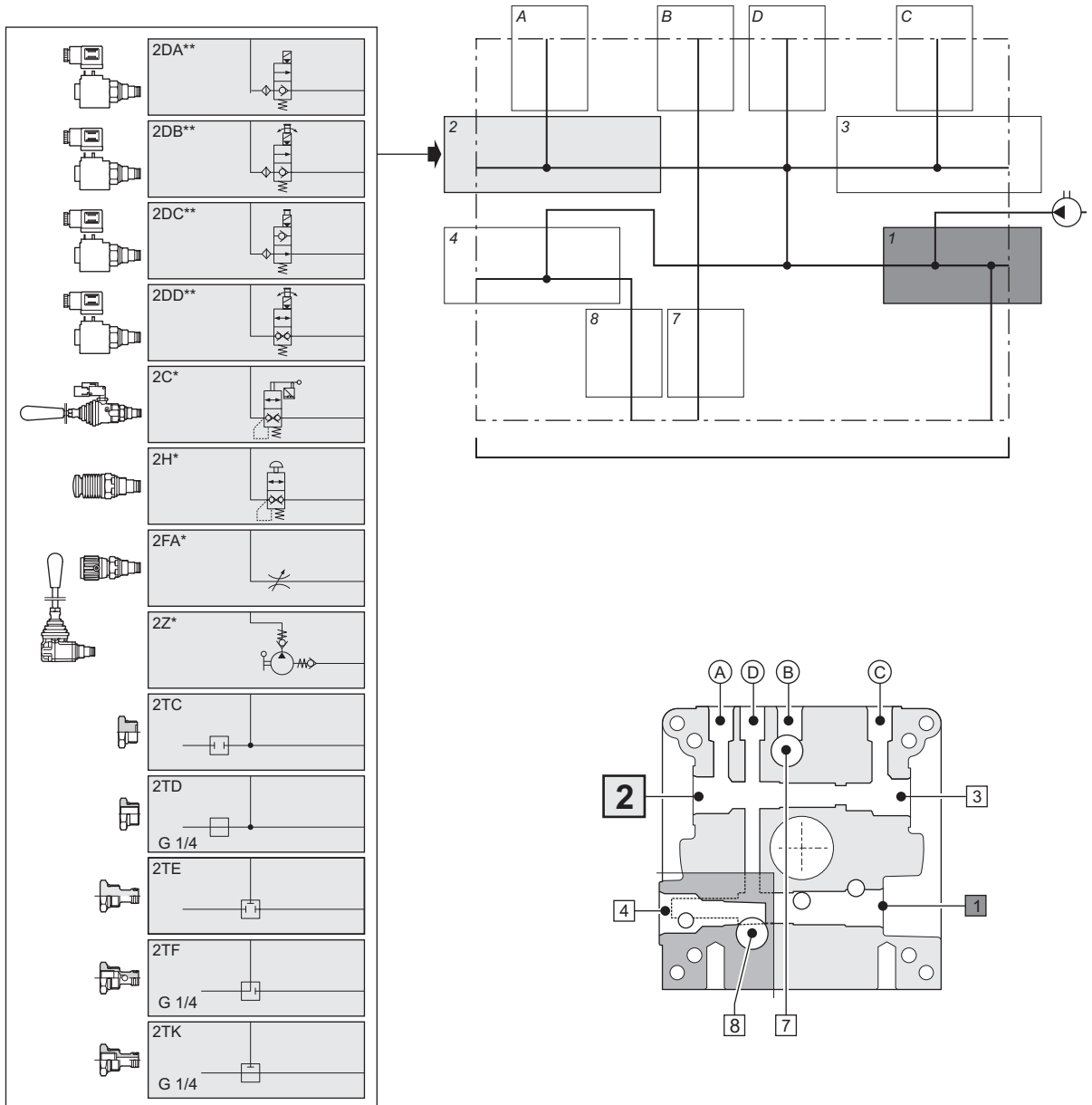
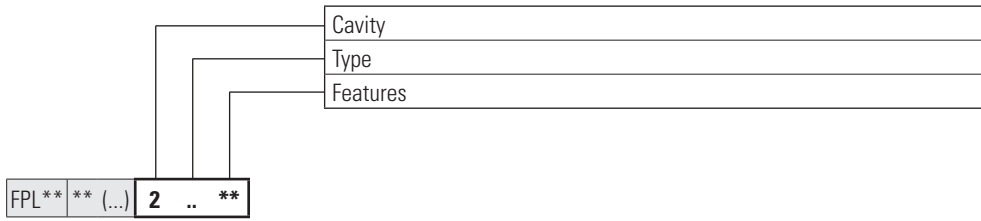

FPL
II

2 DA ** *Piloted solenoid valves normally closed, without emergency*

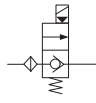
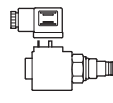
| ** | Description | Code (valve + connector) | Symbol | Drawing |
|----|-----------------------|-----------------------------|---|---|
| AA | Voltage 12 Vdc | CRP0418NCASL003 + V86050002 |  |  |
| AB | Voltage 24 Vdc | CRP0418NCASM003 + V86050002 | | |
| AC | Voltage 24 Vac 50 Hz | CRP0418NCASA003 + V86050002 | | |
| AD | Voltage 115 Vac 50 Hz | CRP0418NCASJ003 + V86050002 | | |
| AE | Voltage 230 Vac 50 Hz | CRP0418NCASI003 + V86050002 | | |

2 DB ** *Piloted solenoid valves normally closed, with emergency*

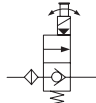
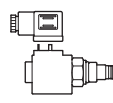
| ** | Description | Code (valve + connector) | Symbol | Drawing |
|----|-----------------------|-----------------------------|---|---|
| AA | Voltage 12 Vdc | CRP0418NCAEL003 + V86050002 |  |  |
| AB | Voltage 24 Vdc | CRP0418NCAEL003 + V86050002 | | |
| AC | Voltage 24 Vac 50 Hz | CRP0418NCAEA003 + V86050002 | | |
| AD | Voltage 115 Vac 50 Hz | CRP0418NCAEJ003 + V86050002 | | |
| AE | Voltage 230 Vac 50 Hz | CRP0418NCAEI003 + V86050002 | | |

2 DC ** *Piloted solenoid valves normally open, with emergency*

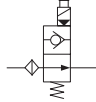
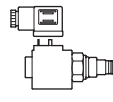
| ** | Description | Code (valve + connector) | Symbol | Drawing |
|----|--|-----------------------------|---|---|
| AA | Voltage 12 Vdc | CRP0418NAAEL003 + V86050002 |  |  |
| AB | Voltage 24 Vdc | CRP0418NAAEM003 + V86050002 | | |
| AC | Voltage 24 Vac 50/60 Hz (RAC with rectifier) | CRP0418NAAE2003 + V86200002 | | |
| AD | Voltage 115 Vac 50 - 120 Vac 60 Hz (RAC with rectifier) | CRP0418NAAEZ003 + V86200002 | | |
| AE | Voltage 230 Vac 50 - 240 Vac 60 Hz (RAC with rectifier) | CRP0418NAAEX003 + V86200002 | | |
| AF | Voltage 48 Vdc | CRP0418NAAEN003 + V86050002 | | |

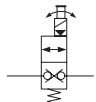
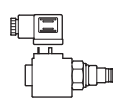

2 DD ** *Direct operated solenoid valve normally closed, with emergency*

| ** | Description | Code (valve + connector) | Symbol | Drawing |
|----|----------------|-----------------------------|---|---|
| AA | Voltage 12 Vdc | CRD0418NCAEL002 + V86050002 |  |  |
| AB | Voltage 24 Vdc | CRD0418NCAEM002 + V86050002 | | |

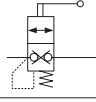
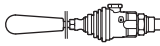
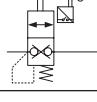
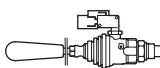

2 C * *Lever operated valve*

| ** | Description | Code | Symbol | Drawing |
|----|---------------------|-----------|---|---|
| A | Without microswitch | CMF04L001 |  |  |
| B | With microswitch | CMF04M001 |  |  |

2 H * *Button operated valves*

| ** | Description | Code | Symbol | Drawing |
|----|---------------------|-------------|---|---|
| A | Push-button control | CPE04P000.1 |  |  |







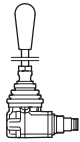



2 FA * *Bidirectional flow control valves not compensated*

| * | Description | Code | Symbol | Drawing |
|---|-------------------------|------------|---|---|
| A | Screw adjustment | CSB04C0000 |  |  |
| B | Plastic knob adjustment | CSB04V0000 | |  |

2 Z * *Hand pumps*

| * | Description | Code | Symbol | Drawing |
|---|-------------------|------------|--|--|
| A | Displacement 1 cc | CPM0410001 |  |  |
| B | Displacement 2 cc | CPM0420001 | | |

2 T * *Plugs and fittings*

| * | Description | Code | Symbol | Drawing |
|---|-------------------------------|-----------|---|---|
| C | Plug 3/4 16 UNF | R78150099 |  |  |
| D | Fitting 3/4 16 UNF - G1/4 | 20001700 |  |  |
| E | Long plug 3/4 16 UNF | 20003800 |  |  |
| F | Fitting 3/4 16 UNF - G1/4 | 20009400 |  |  |
| K | Fitting 3/4 16 UNF DIN - G1/4 | 20018000 |  |  |

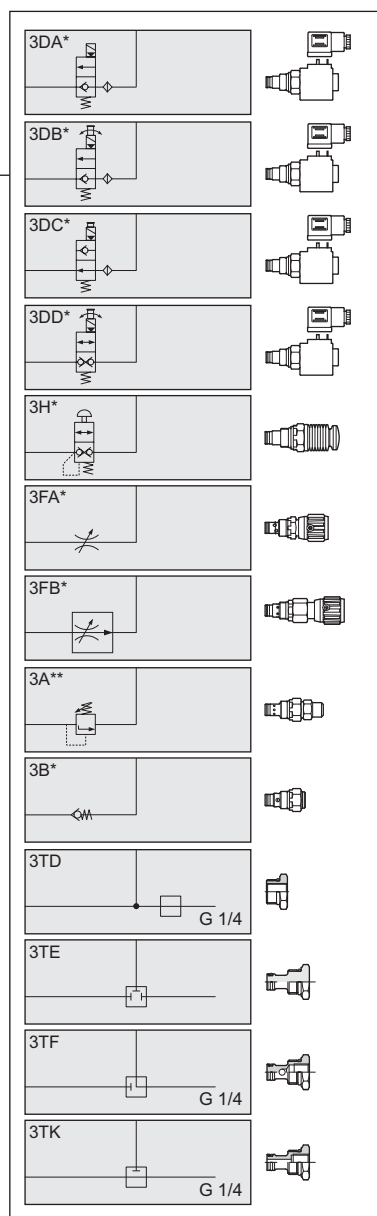
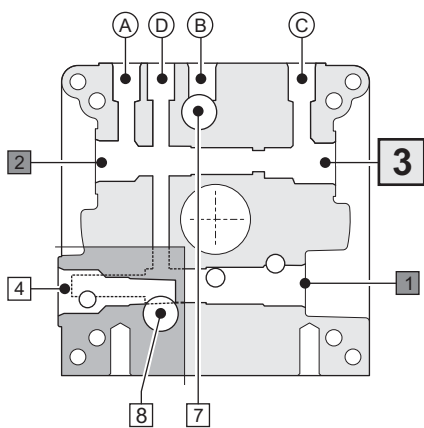
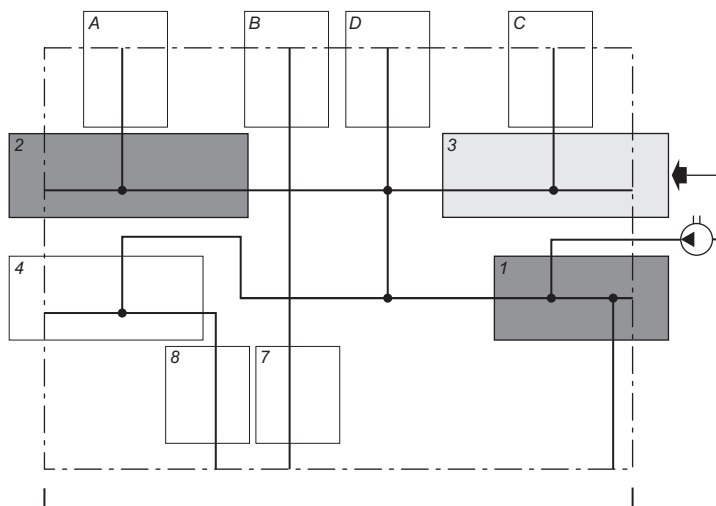
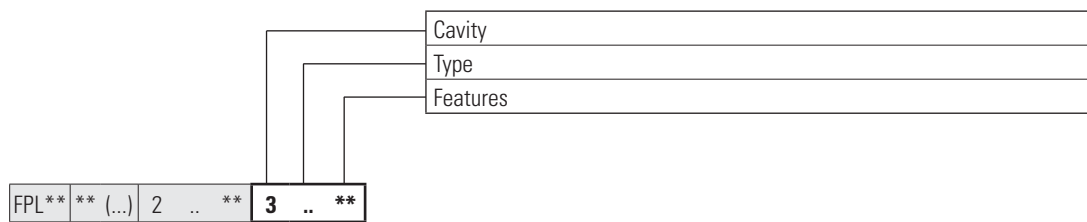

FPL

II

3 DA ** *Piloted solenoid valves normally closed, without emergency*

| ** | Description | Code (valve + connector) | Symbol | Drawing |
|----|-----------------------|-----------------------------|--------|---------|
| AA | Voltage 12 Vdc | CRP0418NCASL003 + V86050002 | | |
| AB | Voltage 24 Vdc | CRP0418NCASM003 + V86050002 | | |
| AC | Voltage 24 Vac 50 Hz | CRP0418NCASA003 + V86050002 | | |
| AD | Voltage 115 Vac 50 Hz | CRP0418NCASJ003 + V86050002 | | |
| AE | Voltage 230 Vac 50 Hz | CRP0418NCASI003 + V86050002 | | |

3 DB ** *Piloted solenoid valves normally closed, with emergency*

| ** | Description | Code (valve + connector) | Symbol | Drawing |
|----|-----------------------|-----------------------------|--------|---------|
| AA | Voltage 12 Vdc | CRP0418NCAEL003 + V86050002 | | |
| AB | Voltage 24 Vdc | CRP0418NCAEL003 + V86050002 | | |
| AC | Voltage 24 Vac 50 Hz | CRP0418NCAEA003 + V86050002 | | |
| AD | Voltage 115 Vac 50 Hz | CRP0418NCAEJ003 + V86050002 | | |
| AE | Voltage 230 Vac 50 Hz | CRP0418NCAEI003 + V86050002 | | |

3 DC ** *Piloted solenoid valves normally open, with emergency*

| ** | Description | Code (valve + connector) | Symbol | Drawing |
|----|--|-----------------------------|--------|---------|
| AA | Voltage 12 Vdc | CRP0418NAAEL003 + V86050002 | | |
| AB | Voltage 24 Vdc | CRP0418NAAEM003 + V86050002 | | |
| AC | Voltage 24 Vac 50/60 Hz (RAC with rectifier) | CRP0418NAAE2003 + V86200002 | | |
| AD | Voltage 115 Vac 50 - 120 Vac 60 Hz (RAC with rectifier) | CRP0418NAAEZ003 + V86200002 | | |
| AE | Voltage 230 Vac 50 - 240 Vac 60 Hz (RAC with rectifier) | CRP0418NAAEX003 + V86200002 | | |
| AF | Voltage 48 Vdc | CRP0418NAAEN003 + V86050002 | | |

3 DD ** *Piloted solenoid valves normally closed, with emergency*

| ** | Description | Code (valve + connector) | Symbol | Drawing |
|----|----------------|-----------------------------|--------|---------|
| AA | Voltage 12 Vdc | CRD0418NCAEL002 + V86050002 | | |
| AB | Voltage 24 Vdc | CRD0418NCAEM002 + V86050002 | | |

3 H * *Button operated valves*



| ** | Description | Code | Symbol | Drawing |
|----|---------------------|-------------|--------|---------|
| A | Push-button control | CPE04P000.1 | | |

3 FA * *Bidirectional flow control valves not compensated*

| * | Description | Code | Symbol | Drawing |
|---|-------------------------|------------|--------|---------|
| A | Screw adjustment | CSB04C0000 | | |
| B | Plastic knob adjustment | CSB04V0000 | | |

FPL
II



3 FB * Unidirectional flow control valves compensated

| * | Description | Code | Symbol | Drawing |
|---|-------------------------|------------|---|---|
| A | Screw adjustment | CSC04C0000 |  |  |
| B | Plastic knob adjustment | CSC04V0000 | |  |









3 A ** Pressure relief valves

| ** | Description | Regolazione (bar) | Code | Symbol | Drawing |
|----|--------------------------|-------------------|------------|---|---|
| AA | Short screw adjustment | Min 10 - Max 70 | CMP04E1001 |  |  |
| AB | | Min 80 - Max 140 | CMP04E2001 | | |
| AC | | Min 100 - Max 330 | CMP04E3001 | | |
| BA | Screw adjustment | Min 10 - Max 70 | CMP04C1001 | | |
| BB | | Min 80 - Max 140 | CMP04C2001 | |  |
| BC | | Min 100 - Max 330 | CMP04C3001 | | |
| CA | Plastic knob adjustment | Min 10 - Max 70 | CMP04V1001 | | |
| CB | | Min 80 - Max 140 | CMP04V2001 | |  |
| CC | | Min 100 - Max 330 | CMP04V3001 | | |
| DA | Short screw + sealed cap | Min 10 - Max 70 | CMP04P1001 | | |
| DB | | Min 80 - Max 140 | CMP04P2001 | | |
| DC | | Min 100 - Max 330 | CMP04P3001 | | |

3 B * One-way check valves

| * | Opening pressure | Code | Symbol | Drawing |
|---|--------------------|------------|---|---|
| A | 0,7 bar (Standard) | CRU0400002 |  |  |
| B | 4,5 bar | CRU0404002 | | |
| C | 10 bar | CRU0410002 | | |

3 T * Plugs and fittings

| * | Description | Code | Symbol | Drawing |
|---|-------------------------------|----------|---|---|
| D | Fitting 3/4 16 UNF - G1/4 | 20001700 |  |  |
| E | Long plug 3/4 16 UNF | 20003800 |  |  |
| F | Fitting 3/4 16 UNF - G1/4 | 20009400 |  |  |
| K | Fitting 3/4 16 UNF - DIN G1/4 | 20018000 |  |  |

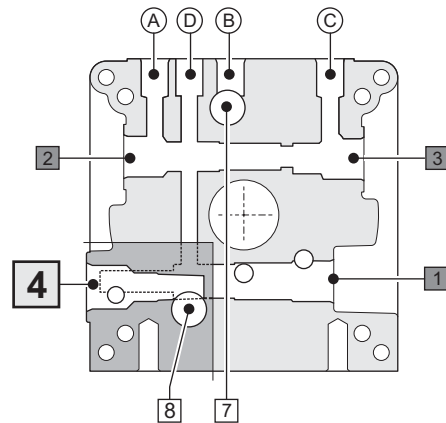
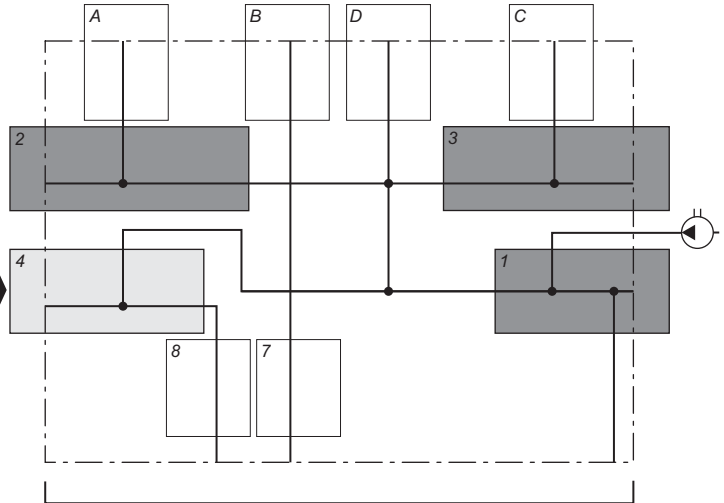
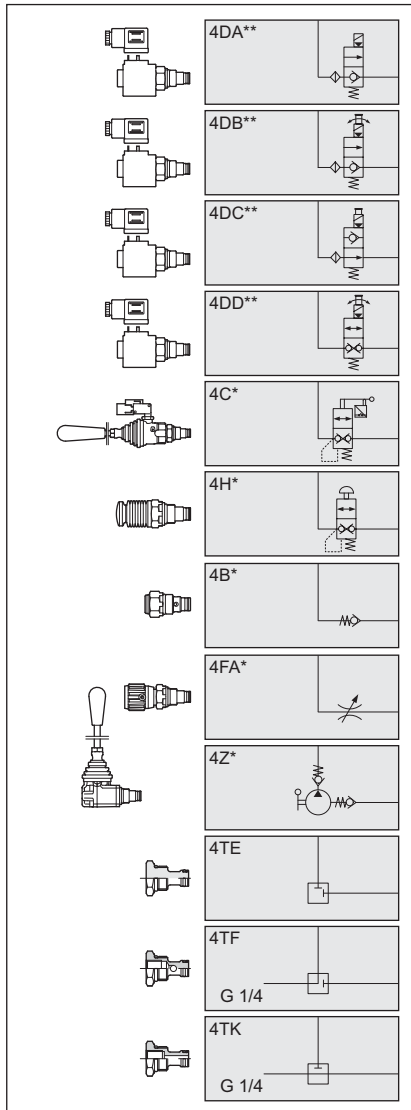
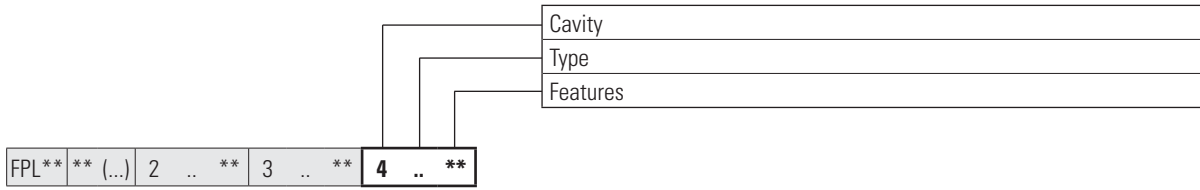

FPL
II

4 DA ** *Piloted solenoid valves normally closed, without emergency*

| ** | Description | Code (valve + connector) | Symbol | Drawing |
|----|-----------------------|-----------------------------|--------|---------|
| AA | Voltage 12 Vdc | CRP0418NCASL003 + V86050002 | | |
| AB | Voltage 24 Vdc | CRP0418NCASM003 + V86050002 | | |
| AC | Voltage 24 Vac 50 Hz | CRP0418NCASA003 + V86050002 | | |
| AD | Voltage 115 Vac 50 Hz | CRP0418NCASJ003 + V86050002 | | |
| AE | Voltage 230 Vac 50 Hz | CRP0418NCASI003 + V86050002 | | |

4 DB ** *Piloted solenoid valves normally closed, with emergency*

| ** | Description | Code (valve + connector) | Symbol | Drawing |
|----|-----------------------|-----------------------------|--------|---------|
| AA | Voltage 12 Vdc | CRP0418NCAEL003 + V86050002 | | |
| AB | Voltage 24 Vdc | CRP0418NCAEM003 + V86050002 | | |
| AC | Voltage 24 Vac 50 Hz | CRP0418NCAEA003 + V86050002 | | |
| AD | Voltage 115 Vac 50 Hz | CRP0418NCAEJ003 + V86050002 | | |
| AE | Voltage 230 Vac 50 Hz | CRP0418NCAEI003 + V86050002 | | |

4 DC ** *Piloted solenoid valves normally open, with emergency*

| ** | Description | Code (valve + connector) | Symbol | Drawing |
|----|--|-----------------------------|--------|---------|
| AA | Voltage 12 Vdc | CRP0418NAAEL003 + V86050002 | | |
| AB | Voltage 24 Vdc | CRP0418NAAEM003 + V86050002 | | |
| AC | Tensione 24 Vac 50/60 Hz (RAC with rectifier) | CRP0418NAAE2003 + V86200002 | | |
| AD | Voltage 115 Vac 50 - 120 Vac 60 Hz (RAC with rectifier) | CRP0418NAAEZ003 + V86200002 | | |
| AE | Voltage 230 Vac 50 - 240 Vac 60 Hz (RAC with rectifier) | CRP0418NAAEX003 + V86200002 | | |
| AF | Tensione 48 Vdc | CRP0418NAAEN003 + V86050002 | | |



4 DD ** *Direct operated solenoid valve normally closed, with emergency*

| ** | Description | Code (valve + connector) | Symbol | Drawing |
|----|----------------|-----------------------------|--------|---------|
| AA | Voltage 12 Vdc | CRD0418NCAEL002 + V86050002 | | |
| AB | Voltage 24 Vdc | CRD0418NCAEM002 + V86050002 | | |



4 C * *Lever operated valve*

| ** | Description | Code | Symbol | Drawing |
|----|---------------------|------------|--------|---------|
| A | Without microswitch | CMF04L0001 | | |
| B | With microswitch | CMF04M0001 | | |

4 B * One-way check valves

| * | Opening pressure | Code | Symbol | Drawing |
|---|--------------------|------------|---|---|
| A | 0,7 bar (Standard) | CRU0400002 |  |  |
| B | 4,5 bar | CRU0404002 | | |
| C | 10 bar | CRU0410002 | | |

4 H * Button operated valves

| ** | Description | Code | Symbol | Drawing |
|----|---------------------|-------------|---|---|
| A | Push-button control | CPE04P000.1 |  |  |



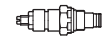
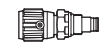

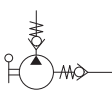
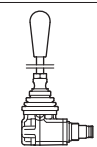

4 FA * Bidirectional flow control valves not compensated

| * | Description | Code | Symbol | Drawing |
|---|-------------------------|------------|---|--|
| A | Screw adjustment | CSB04C0000 |  |  |
| B | Plastic knob adjustment | CSB04V0000 | |  |

4 Z * Hand pumps

| * | Description | Code | Symbol | Drawing |
|---|-------------------|------------|---|---|
| A | Displacement 1 cc | CPM0410001 |  |  |
| B | Displacement 2 cc | CPM0420001 | | |

4 T * Plugs and fittings

| * | Description | Code | Symbol | Drawing |
|---|-------------------------------|----------|---|---|
| E | Long plug 3/4 16 UNF | 20003800 |  |  |
| F | Fitting 3/4 16 UNF - G1/4 | 20009400 |  |  |
| K | Fitting 3/4 16 UNF DIN - G1/4 | 20018000 |  |  |

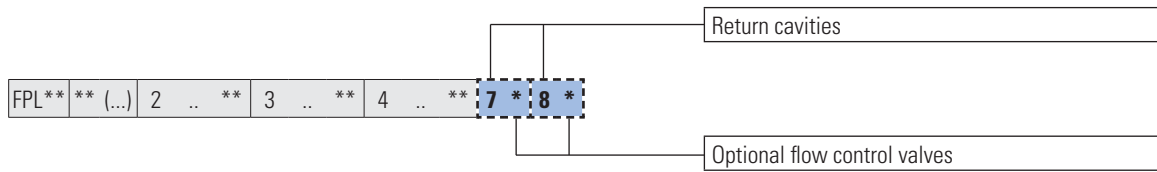

Return cavity, omit if not required flow control valves

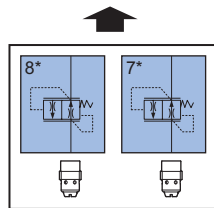
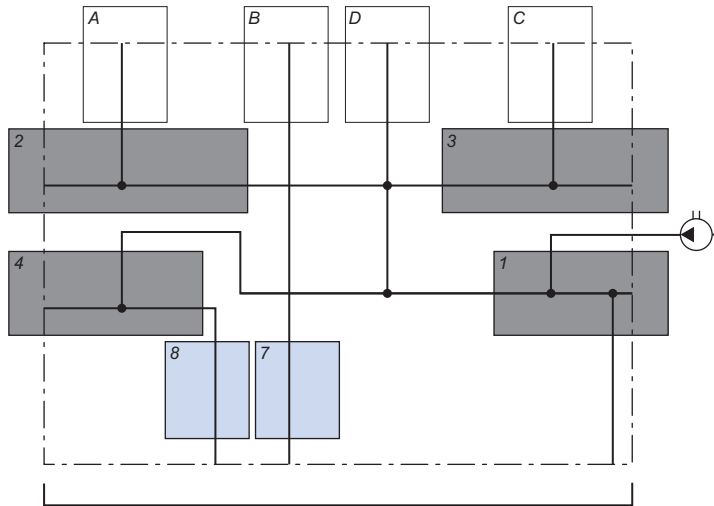

Optional flow control valves

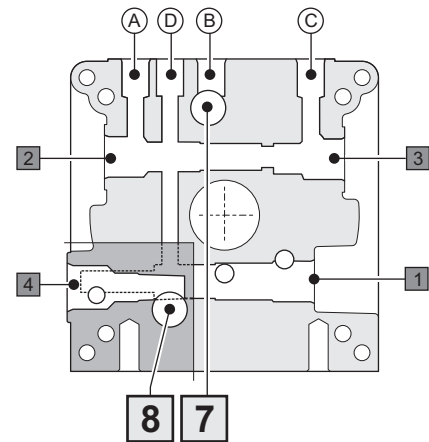

FPL
II

7 *
8 **Flow control valves for return cavities "7-8"**

| * A B C E G K N Q U V | Nominal flow at 120 bar | Code | Symbol | Drawing |
|---|-------------------------|-------------|--------|---------|
| A | 0.7 l/min | VSC06100002 | | |
| B | 1.1 l/min | VSC06120002 | | |
| C | 2.1 l/min | VSC06130002 | | |
| E | 3.2 l/min | VSC06150002 | | |
| G | 4.7 l/min | VSC06190002 | | |
| K | 6.3 l/min | VSC06220002 | | |
| N | 7.5 l/min | VSC06240002 | | |
| Q | 10.0 l/min | VSC06280002 | | |
| U | 13.2 l/min | VSC06330002 | | |
| V | 15.7 l/min | VSC06350002 | | |

Possible combinations plugs on ports
End section II

FPL** ** (...) 2 .. ** 3 .. ** 4 .. ** 7 * 8 * **-****

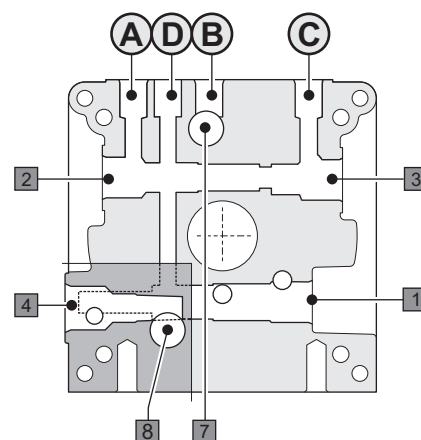
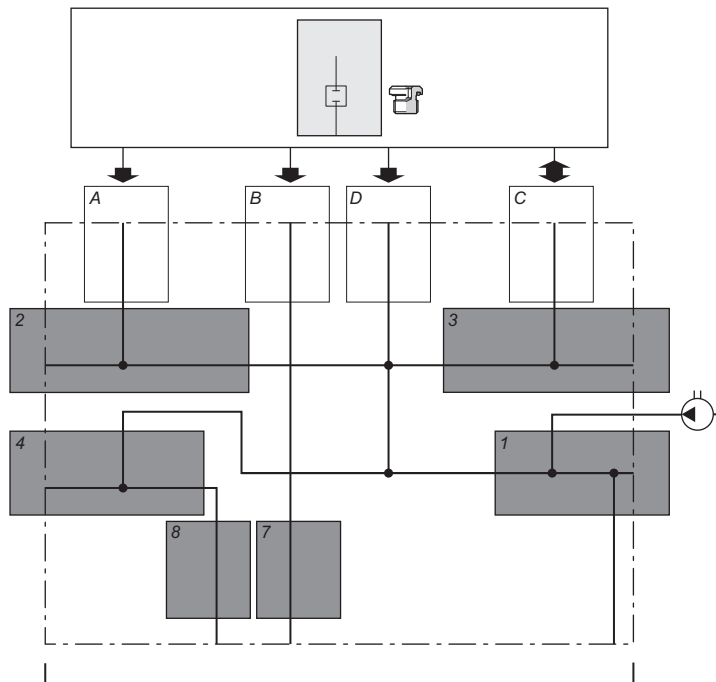

FPL
II

-** Possible combinations plugs on ports **A-B-C-D**

| -** | A | B | C | D |
|-----|---|---|---|---|
| -00 | ↑ | ⊗ | ↑ | ⊗ |
| -01 | ↑ | ↑ | ↑ | ↑ |
| -03 | ↑ | ⊗ | ↑ | ↑ |
| -04 | ↑ | ↑ | ↑ | ⊗ |

Symbols description

| Type | Description | Thread | Code | Symbol | Drawing |
|------|-----------------------|--------|----------|--------|---------|
| ⊗ | Port closed with plug | G 1/4" | 20024000 | | |
| ↑ | Open port | | — | — | — |

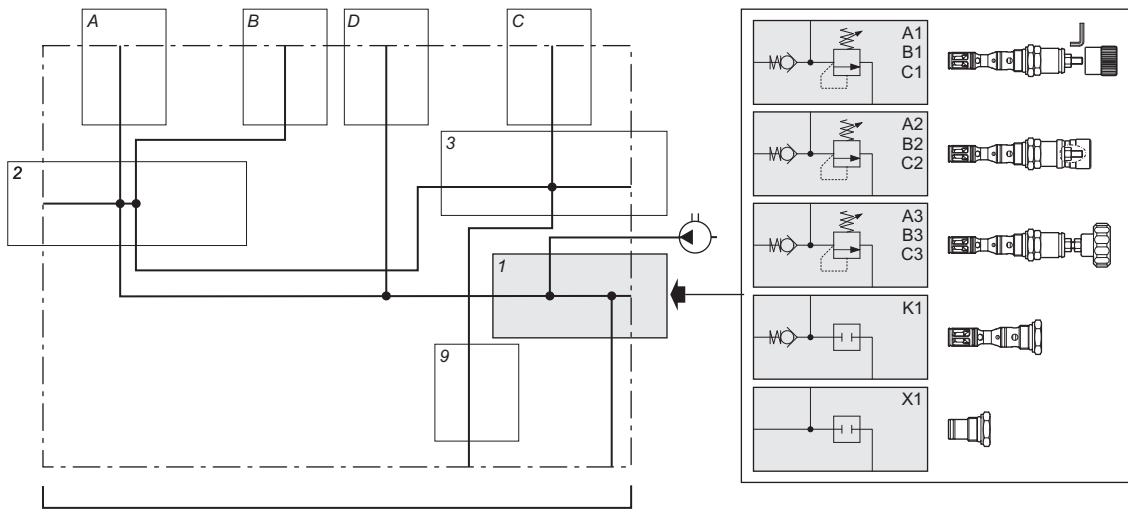
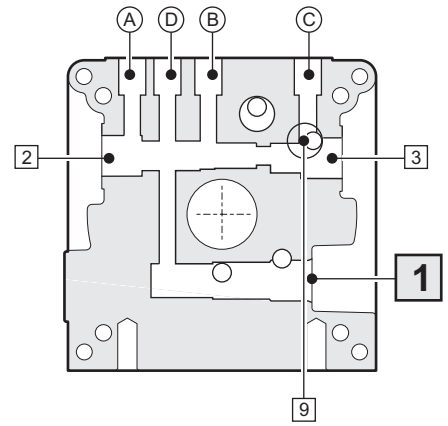
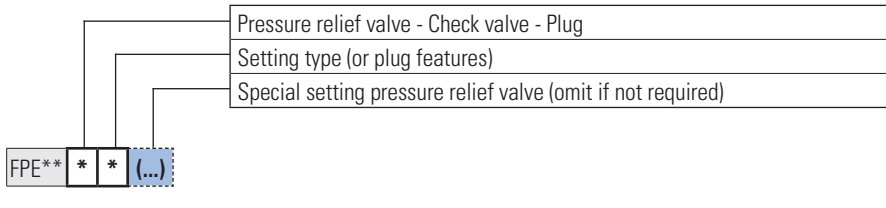

FPE
I

*** * (...)** *Pressure relief valve with check valve*

| * | * | Pressure (bar) | STD setting (bar) | (...) Special setting (bar) | Setting type | Code | Symbol | Drawing |
|---|---|----------------|-------------------|-----------------------------|---------------------------|--------------|--------|---------|
| A | 1 | 10 ÷ 60 | 50 | 10 ÷ 60 (5 to 5) | Detachable closing | CMPR04S01001 | | |
| | 2 | | | | Non removable closing (1) | CMPR04P01001 | | |
| | 3 | | | | Handwheel | CMPR04V01001 | | |
| B | 1 | > 60 ÷ 180 | 150 | 65 ÷ 180 (5 to 5) | Detachable closing | CMPR04S02001 | | |
| | 2 | | | | Non removable closing (1) | CMPR04P02001 | | |
| | 3 | | | | Handwheel | CMPR04V02001 | | |
| C | 1 | > 180 ÷ 320 | 210 | 190 ÷ 320 (10 to 10) | Detachable closing | CMPR04S03001 | | |
| | 2 | | | | Non removable closing (1) | CMPR04P03001 | | |
| | 3 | | | | Handwheel | CMPR04V03001 | | |

1 = Supplied assembled. Unassembled, see accessories page 89.

*** *** *Check valve and plug*

| * | * | Description | Code | Symbol | Drawing |
|---|---|--|------------|--------|---------|
| K | 1 | Check valve - Opening pressure 0.5 bar | CR10400001 | | |
| X | 1 | Plug | R78150100 | | |

Sect. II - FPE Cavity 2

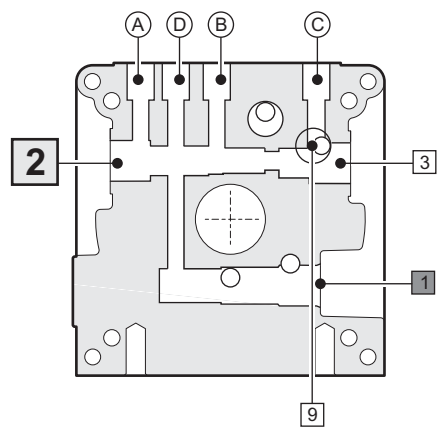
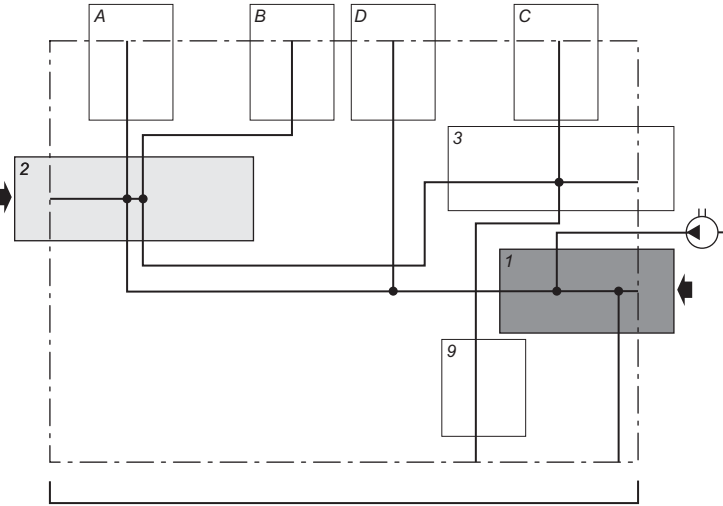
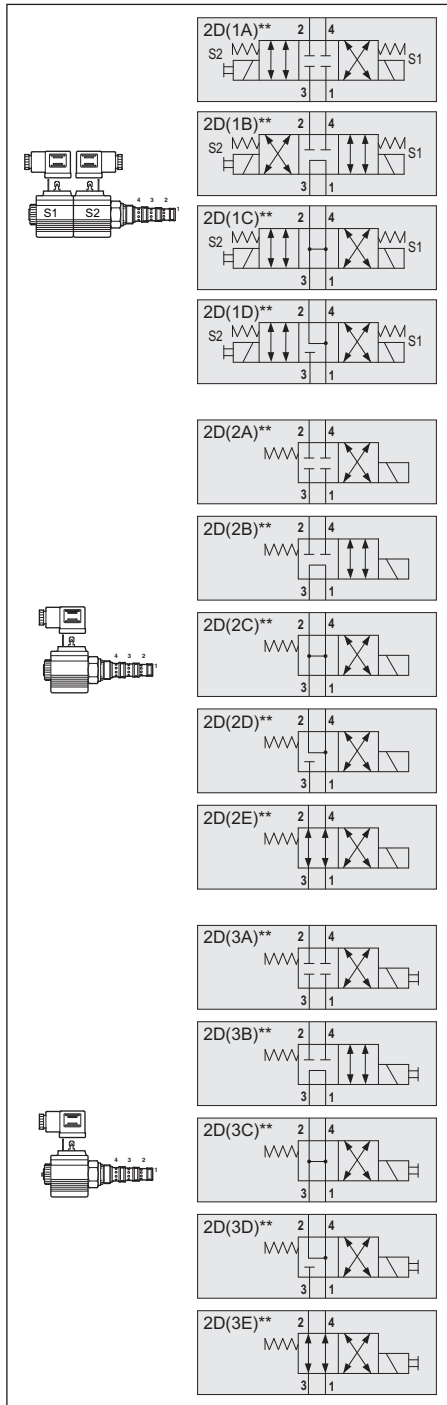
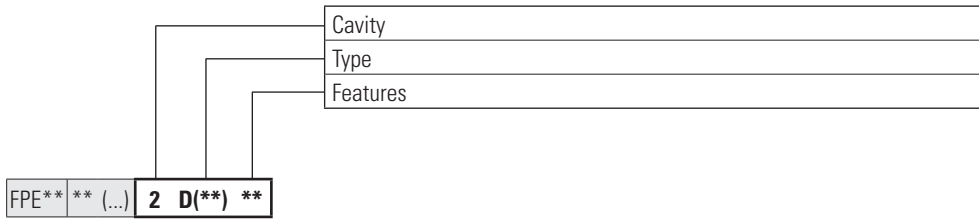

FPE
II

2 D(**) ** Solenoid valves 4 way 3 positions with emergency

| (**)** | Description | Code (valve + connectors) | Symbol | Drawing |
|--------|--|----------------------------------|--------|---------|
| (1A)AA | Voltage 12 Vdc (closed centre "C" spool) | C4V0422C3FEL001 + V86050002 (x2) | | |
| (1A)AB | Voltage 24 Vdc (closed centre "C" spool) | C4V0422C3FEM001 + V86050002 (x2) | | |
| (1B)AA | Voltage 12 Vdc (open centre "A" spool) | C4V0422A3FEL001 + V86050002 (x2) | | |
| (1B)AB | Voltage 24 Vdc (open centre "A" spool) | C4V0422A3FEM001 + V86050002 (x2) | | |
| (1C)AA | Voltage 12 Vdc (centre "H" spool) | C4V0422H3FEL001 + V86050002 (x2) | | |
| (1C)AB | Voltage 24 Vdc (centre "H" spool) | C4V0422H3FEM001 + V86050002 (x2) | | |
| (1D)AA | Voltage 12 Vdc (centre "Y" spool) | C4V0422Y3FEL001 + V86050002 (x2) | | |
| (1D)AB | Voltage 24 Vdc (centre "Y" spool) | C4V0422Y3FEM001 + V86050002 (x2) | | |

2 D(**) ** Solenoid valves 4 way 2 positions without emergency

| (**)** | Description | Code (valve + connectors) | Symbol | Drawing |
|--------|--|-----------------------------|--------|---------|
| (2A)AA | Voltage 12 Vdc (closed centre "C" spool) | C4V0422C2FSL001 + V86050002 | | |
| (2A)AB | Voltage 24 Vdc (closed centre "C" spool) | C4V0422C2FSM001 + V86050002 | | |
| (2B)AA | Voltage 12 Vdc (open centre "A" spool) | C4V0422A2FSL001 + V86050002 | | |
| (2B)AB | Voltage 24 Vdc (open centre "A" spool) | C4V0422A2FSM001 + V86050002 | | |
| (2C)AA | Voltage 12 Vdc (centre "H" spool) | C4V0422H2FSL001 + V86050002 | | |
| (2C)AB | Voltage 24 Vdc (centre "H" spool) | C4V0422H2FSM001 + V86050002 | | |
| (2D)AA | Voltage 12 Vdc (centre "Y" spool) | C4V0422Y2FSL001 + V86050002 | | |
| (2D)AB | Voltage 24 Vdc (centre "Y" spool) | C4V0422Y2FSM001 + V86050002 | | |
| (2E)AA | Voltage 12 Vdc (direct "D" spool) | C4V0422D2FSL001 + V86050002 | | |
| (2E)AB | Voltage 24 Vdc (direct "D" spool) | C4V0422D2FSM001 + V86050002 | | |

2 D(**) ** Solenoid valves 4 way 2 positions with emergency

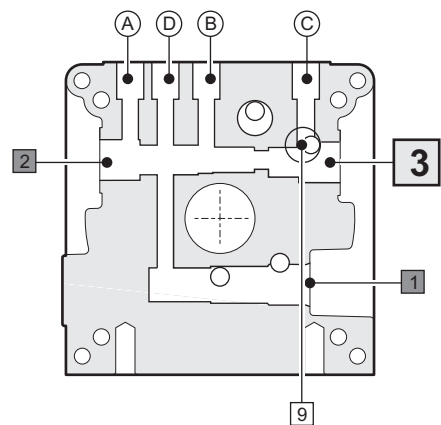
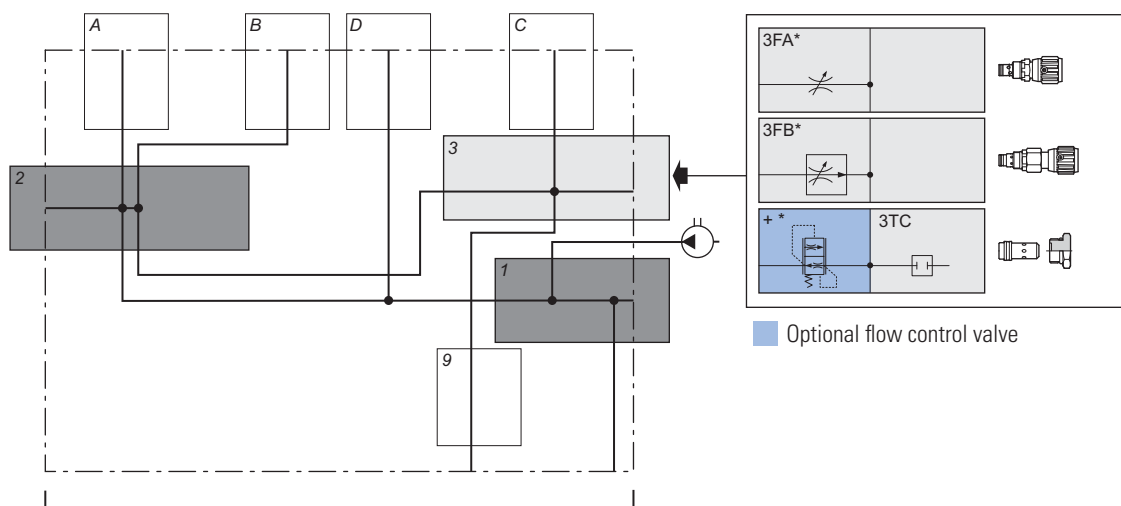
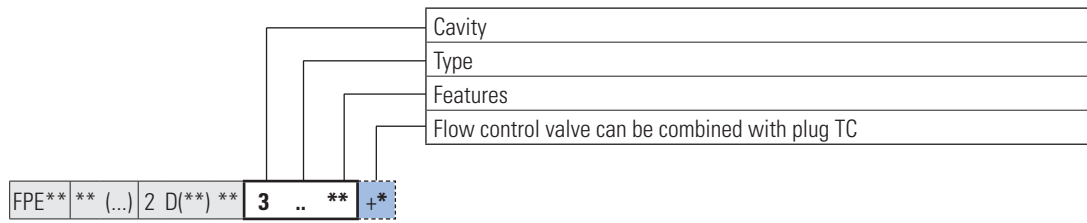

| (**)** | Description | Code (valve + connectors) | Symbol | Drawing |
|--------|--|-----------------------------|--------|---------|
| (3A)AA | Voltage 12 Vdc (closed centre "C" spool) | C4V0422C2FEL001 + V86050002 | | |
| (3A)AB | Voltage 24 Vdc (closed centre "C" spool) | C4V0422C2FEM001 + V86050002 | | |
| (3B)AA | Voltage 12 Vdc (open centre "A" spool) | C4V0422A2FEL001 + V86050002 | | |
| (3B)AB | Voltage 24 Vdc (open centre "A" spool) | C4V0422A2FEM001 + V86050002 | | |
| (3C)AA | Voltage 12 Vdc (centre "H" spool) | C4V0422H2FEL001 + V86050002 | | |
| (3C)AB | Voltage 24 Vdc (centre "H" spool) | C4V0422H2FEM001 + V86050002 | | |
| (3D)AA | Voltage 12 Vdc (centre "Y" spool) | C4V0422Y2FEL001 + V86050002 | | |
| (3D)AB | Voltage 24 Vdc (centre "Y" spool) | C4V0422Y2FEM001 + V86050002 | | |
| (3E)AA | Voltage 12 Vdc (direct "D" spool) | C4V0422D2FEL001 + V86050002 | | |
| (3E)AB | Voltage 24 Vdc (direct "D" spool) | C4V0422D2FEM001 + V86050002 | | |

Sect. II - FPE Cavity 3





FPE
II



3 FA * Bidirectional flow control valves not compensated

| * | Description | Code | Symbol | Drawing |
|---|-------------------------|------------|---|---|
| A | Screw adjustment | CSB04C0000 |  |  |
| B | Plastic knob adjustment | CSB04V0000 | |  |



3 FB * Bidirectional flow control valves compensated

| * | Description | Code | Symbol | Drawing |
|---|-------------------------|-----------|---|---|
| A | Screw adjustment | CSC04C000 |  |  |
| B | Plastic knob adjustment | CSC04V000 | |  |

3 T * Plugs and fittings

| * | Description | Code | Symbol | Drawing |
|---|---------------------|-----------|---|---|
| C | Plug 3/4 16 UNF (1) | R78150099 |  |  |

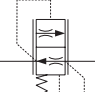
3 T C +* Flow control valves (1)

| * | Flow | Code | Symbol | Drawing |
|----|------------|-----------|---|---|
| +B | 1.4 l/min | VSC040101 |  |  |
| +C | 2.3 l/min | VSC040201 | | |
| +E | 2.8 l/min | VSC040301 | | |
| +G | 4.3 l/min | VSC040401 | | |
| +J | 5.2 l/min | VSC040601 | | |
| +L | 6.5 l/min | VSC040801 | | |
| +N | 8.0 l/min | VSC041101 | | |
| +Q | 11.1 l/min | VSC041601 | | |

(1) | The flow control valve can be installed with the plug TC

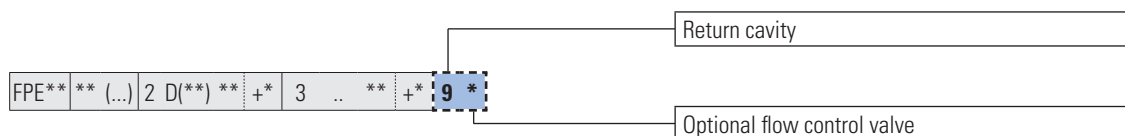

Return cavity, omit if not required flow control valve

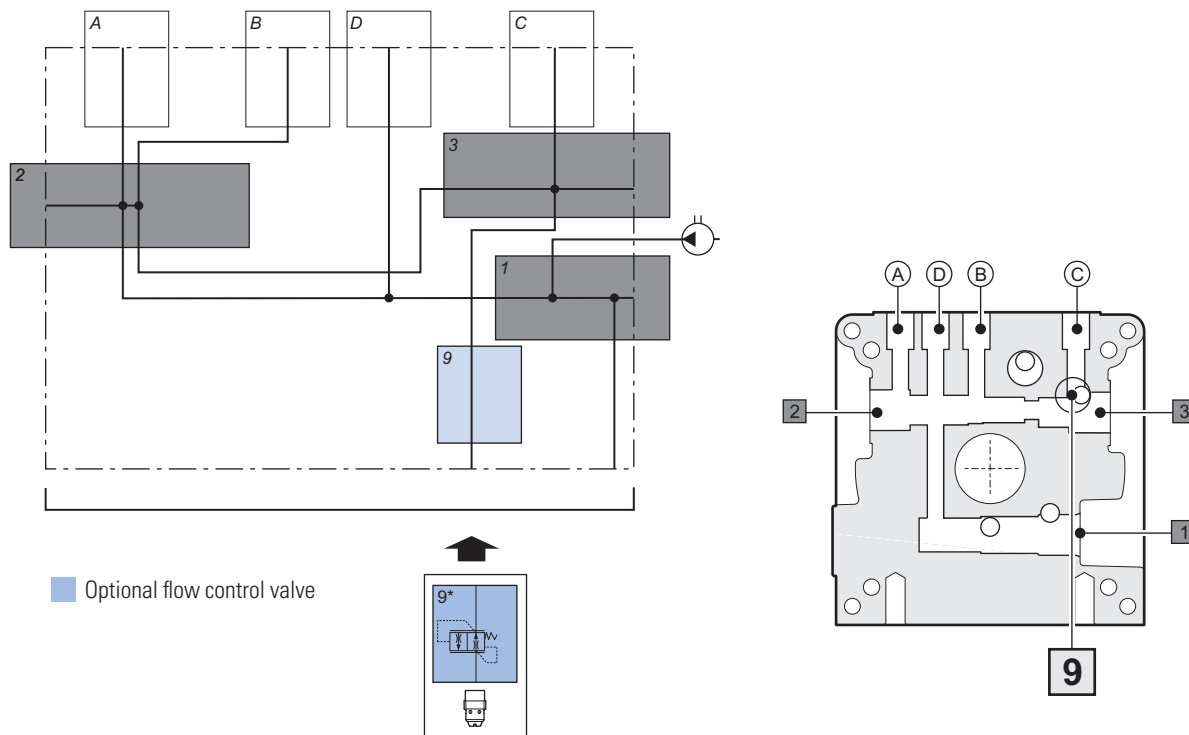

FPE
II

9 * Flow control valves

| * Code | Nominal flow at 120 bar | Code | Symbol | Drawing |
|--------|-------------------------|-------------|--------|---------|
| A | 0.7 l/min | VSC06100002 | | |
| B | 1.1 l/min | VSC06120002 | | |
| C | 2.1 l/min | VSC06130002 | | |
| E | 3.2 l/min | VSC06150002 | | |
| G | 4.7 l/min | VSC06190002 | | |
| K | 6.3 l/min | VSC06220002 | | |
| N | 7.5 l/min | VSC06240002 | | |
| Q | 10.0 l/min | VSC06280002 | | |
| U | 13.2 l/min | VSC06330002 | | |
| V | 15.7 l/min | VSC06350002 | | |

Possible combinations plugs on ports
End section II

FPE** ** (...) 2 D(**) **: +* 3 .. **: +* 9 * **-**** -

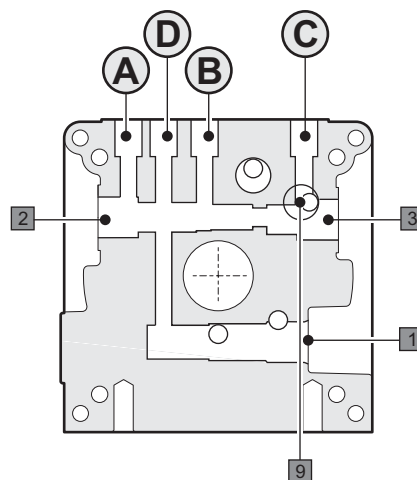
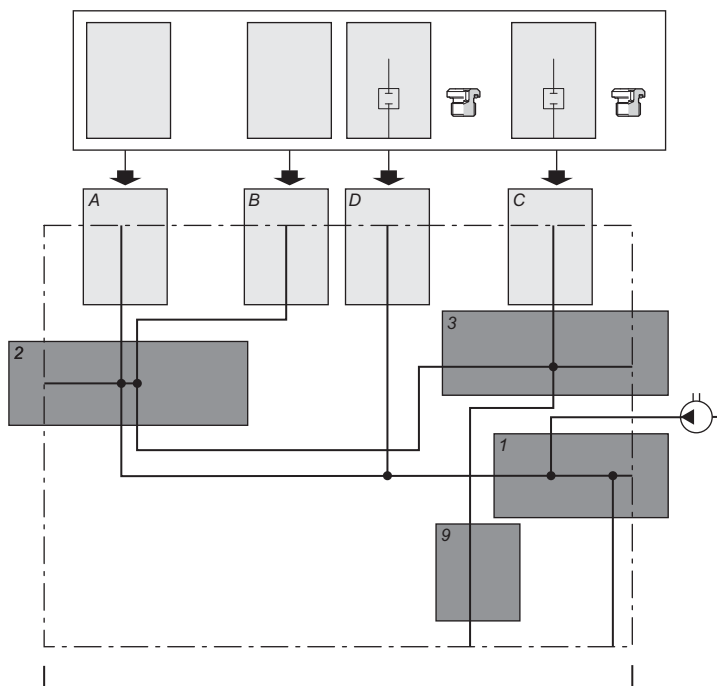

FPE

II

-** Possible combinations plugs on ports A-B-C-D

Symbols description

| -** | A | B | C | D | Type | Description | Code | Symbol | Drawing |
|-----|---|---|---|---|------|-----------------------|----------|--------|---------|
| -00 | ↑ | ↑ | ⊗ | ↑ | ⊗ | Port closed with plug | 20024000 | | |
| -01 | ↑ | ↑ | ↑ | ⊗ | ↑ | Open port | — | — | — |
| -03 | ↑ | ⊗ | ↑ | ⊗ | | | | | |
| -04 | ↑ | ↑ | ⊗ | ⊗ | | | | | |

With the FPE hydraulic power pack, cannot be mounted the standard blocks.

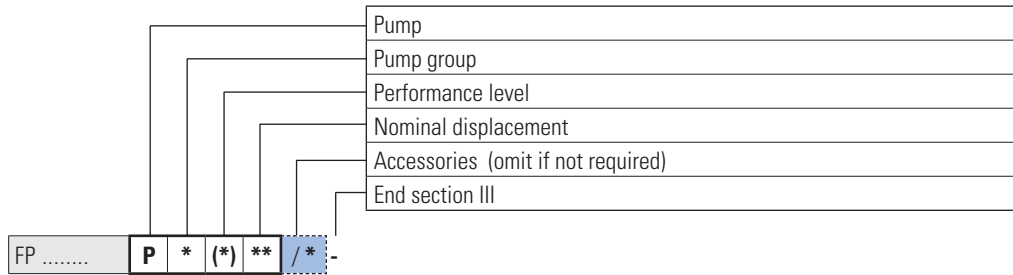

P 0 (1) ** **Pumps group 05 - Performance level 1**

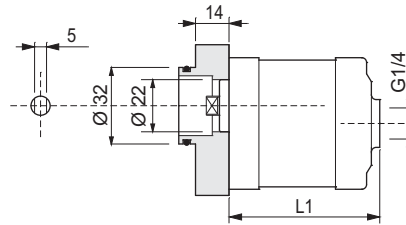

| ** | Nominal displacement | Tolerance on geometric displacement | P2 bar | P3 bar | Code complete kit | L1 mm | Tanks not compatible (•) | | | | Motors not compatible | | | | |
|----|----------------------|-------------------------------------|--------|--------|-------------------|-------|--------------------------|-----|------|-----|-----------------------|---|-----|-----|-----|
| | | | | | | | S01A | | S09E | | | S02G | | All | |
| | | | | | | | (H) | (V) | (H) | (V) | | (H) | (V) | (H) | (V) |
| 02 | 0.25 cc | 0.25 ÷ 0.33 | 230 | 270 | 17050037.035 | 54 | | | | | | M4FB(1) - M4GJ(1) MM*PA(1) M*AA(1)D - M*AA(1)G M*AA(1)H M*AB(1)D - M*AB(1)G M*AB(1)H | | | |
| 04 | 0.45 cc | 0.45 ÷ 0.55 | 230 | 270 | 17050036.035 | 55.7 | | | | | | | | | |
| 05 | 0.56 cc | 0.56 ÷ 0.68 | 230 | 270 | 17050039.035 | 56.7 | | • | | • | | | | | |
| 07 | 0.75 cc | 0.69 ÷ 0.82 | 230 | 270 | 17050038.035 | 58.5 | | • | | • | | | | | |
| 09 | 0.92 cc | 0.83 ÷ 0.95 | 230 | 270 | 17050053.035 | 59.8 | | • | | • | | | | | |

P2 = Intermittent operating pressure
 P3 = Intermittent peak pressure (20 sec. max)

Tanks not compatible (as dimensions, see page 55)
 Motors not compatible (interface and transmission not supplied, see pages 71 - 77)

P 1 (1) ** **Pumps group 1 - Performance level 1**

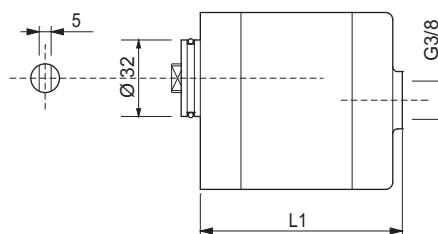

| ** | Nominal displacement | Tolerance on geometric displacement | P2 bar | P3 bar | Code complete kit | L1 mm | Tanks not compatible (•) | | | | | | | |
|----|----------------------|-------------------------------------|--------|--------|-------------------|-------|--------------------------|-----|------|-----|------|-----|-----|-----|
| | | | | | | | S01A | | S09E | | S02G | | All | |
| | | | | | | | (H) | (V) | (H) | (V) | (H) | (V) | (H) | (V) |
| 07 | 0.80 cc | 0.69 ÷ 0.82 | 170 | 210 | 17050107.018 | 72.4 | | • | | | | | | |
| 10 | 1.00 cc | 0.96 ÷ 1.09 | 170 | 210 | 17050088.018 | 73.5 | | • | | | | | | |
| 12 | 1.20 cc | 1.10 ÷ 1.30 | 250 | 290 | 17050005.018 | 74.8 | | • | | | | | | |
| 17 | 1.70 cc | 1.50 ÷ 1.70 | 250 | 290 | 17050006.018 | 76.2 | | • | | | | | | |
| 22 | 2.20 cc | 2.10 ÷ 2.30 | 250 | 290 | 17050007.018 | 78.2 | | • | | | | | | |
| 26 | 2.60 cc | 2.50 ÷ 2.70 | 250 | 290 | 17050008.018 | 79.7 | | • | | • | | | | |
| 32 | 3.20 cc | 3.10 ÷ 3.32 | 250 | 290 | 17050009.018 | 82.0 | | • | | • | | | | |
| 38 | 3.80 cc | 3.60 ÷ 3.99 | 250 | 290 | 17050010.018 | 84.0 | | • | | • | | | | |
| 43 | 4.30 cc | 4.00 ÷ 4.35 | 250 | 290 | 17050011.018 | 86.6 | | • | | • | | | | |
| 48 | 4.80 cc | 4.85 ÷ 4.95 | 225 | 260 | 17050033.018 | 88.1 | | • | | • | | | | |
| 60 | 6.00 cc | 5.62 ÷ 6.02 | 185 | 215 | 17050012.018 | 92.2 | • | | • | • | • | | | |
| 78 | 7.80 cc | 7.48 ÷ 7.90 | 140 | 160 | 17050013.018 | 98.9 | • | • | • | • | • | | | |
| 98 | 9.80 cc | 9.60 ÷ 10.00 | 110 | 125 | 17050054.018 | 107.2 | • | • | • | • | • | | | |

P2 = Intermittent operating pressure
 P3 = Intermittent peak pressure (20 sec. max)

Tanks not compatible (as dimensions, see page 55).

P 1 (1) ** / * **Accessories for pumps group 1**

Displacement

| * | Description | Type | Code | Symbol |
|----|--|---------------------------------|-------------|--------|
| /A | Single-phase motor start valve - on auxiliary outlet | 0.8 ÷ 2.5 l/min | VAM0400L | |
| /B | | > 2.5 ÷ 8.0 l/min | VAM0400M | |
| /C | | > 8.0 ÷ 14 l/min | VAM0400H | |
| /D | Soft start valve - on auxiliary outlet | hole Ø 0.4 mm max 8 l/min | VAMS0404001 | |

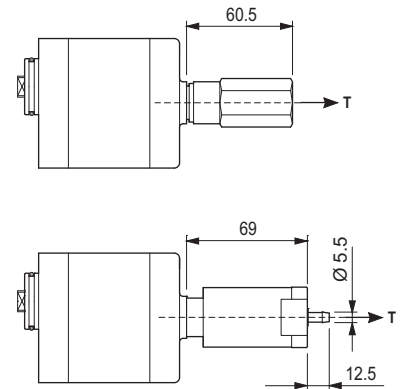

| ** | With accessory | Tanks not compatible (•) | | | |
|----|----------------|--------------------------|------|------|-----|
| | | S01A | S09E | S02G | All |
| 09 | /A /B /C | | | | |
| | /D | • | • | • | |
| 12 | /A /B /C | | | | |
| | /D | • | • | • | |
| 17 | /A /B /C | | | | |
| | /D | • | • | • | |
| 22 | /A /B /C | | | | |
| | /D | • | • | • | |
| 26 | /A /B /C | | | | |
| | /D | • | • | • | |
| 32 | /A /B /C | | • | • | |
| | /D | • | • | • | |
| 38 | /A /B /C | • | • | • | |
| | /D | • | • | • | |
| 43 | /A /B /C | • | • | • | |
| | /D | • | • | • | |

Tanks not compatible (as dimensions, see page 55).

Sect. IV - Tanks / Sect. V - Tubes kit

| |
|--|
| Tank (S = with tank and tubes kit; G = only tubes kit, without tank; OMIT if without tank and without tubes kit) |
| Capacity liters |
| Features (material and construction) |
| Mounting position: (H = horizontal; V = vertical) |
| Variants (00 = standard, no variant) - OMIT if with tubes kit |
| Orientation - OMIT if with tubes kit in vertical mounting position |
| End section IV and V |

FP * ** * (*) ** /* -

| ** | Liters | * Dimensions (mm) | Material | (*) Mounting | ** Variants | Page | * Orientation | Page |
|----|--------|------------------------|----------------------------|---------------|-------------|----------------|---------------------------|------|
| 01 | 1 | A Ø 123 - L 141 | Sheet steel | (H) | 00 | 56 | /1(std) /2 /3 /4 | 69 |
| | 02 | 1,5 | G Ø 130x140 - L 135 | Polyethylene | (V) | | | |
| 03 | | 2 | A Ø 123 - L 200 | Sheet steel | (H) | 00 | | |
| | 04 | 2,5 | G Ø 130x140 - L 235 | Polyethylene | (V) | 00 | | |
| 05 | | 3 | A Ø 123 - L 330 | Sheet steel | (H) | 00 | | |
| | 06 | 4 | G Ø 130x140 - L 295 | Polyethylene | (V) | 00 | | |
| 07 | | 4 | L Ø 180 - L 210 | Polyethylene | (H) | 00 | | |
| | 08 | 5 | B Ø 175 - L 246 | Sheet steel | (V) | 00 | | |
| 09 | | 5 | C Ø 200 - L 210 | Sheet steel | (H) | 00-01-02-03-04 | | |
| | 10 | 5 | F Ø 180 - L 240 | Polypropylene | (V) | 00 | | |
| 11 | | 6 | B Ø 175 - L 308 | Sheet steel | (H) | 00 | | |
| | 12 | 7 | E Ø 154x188 - L 299 | Sheet steel | (V) | 00-04 | | |
| 13 | | 7 | F Ø 180 - L 308 | Polypropylene | (H) | 00 | | |
| | 14 | 7 | L Ø 180 - L 310 | Polyethylene | (V) | 00 | | |
| 15 | | 7 | M Ø 180 - L 335 | Polyethylene | (H) | 00 | | |
| | 16 | 8 | B Ø 175 - L 370 | Sheet steel | (V) | 00 | | |
| 17 | | 8 | C Ø 200 - L 306 | Sheet steel | (H) | 00-04 | | |
| | 18 | 9 | E Ø 230x130 - L 350 | Sheet steel | (V) | 00 | | |
| 19 | | 10 | L Ø 180 - L 370 | Polietilene | (H) | 00 | | |
| | 20 | 10 | C Ø 200 - L 373 | Sheet steel | (V) | 00 | | |
| 21 | | 10 | D Ø 217 - L 273 | Sheet steel | (H) | 00 | | |
| | 22 | 10 | L Ø 180 - L 410 | Polyethylene | (V) | 00 | | |
| 23 | | 12 | D Ø 217 - L 370 | Sheet steel | (H) | 00 | | |
| | 24 | 14 | E Ø 255x193 - L 366 | Sheet steel | (V) | 00 | | |
| 25 | | 25 | E Ø 250x255 - L 436 | Sheet steel | (H) | 00-01 | | |
| | | | | (V) | 00-01 | | | |

IV
V

Sect. IV - Tanks / Sect. V - Tubes kit

* ** * (H) ** * - Tanks Ø 123 - Sheet steel, capacity 1-2-3 liters - Horizontal mounting (black painted)

| Capacity | Features | Mounting | Variant (1) | L (mm) | Capacity (liters) | | | Tank (with plug) | Tank fixing kit (screws and O-Ring) |
|----------|----------|----------|-------------|--------|-------------------|------|--------|------------------|-------------------------------------|
| | | | | | Nominal | Full | Usable | | |
| 01 | | | | 141 | 1 | 1.0 | 0.7 | 90310000 | 17010080 |
| 02 | A | (H) | 00 | 200 | 2 | 1.6 | 1.5 | 90310001 | |
| 03 | | | | 330 | 3 | 3 | 2.8 | 90310002 | |

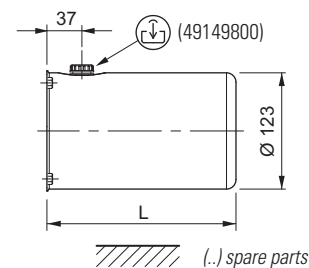

(1) Variant - OMIT if without tank but with tubes kit

Other variants

| Variant | Tank | Variant | Tank | Variant | Tank | Variant | Tank |
|---------|------|---------|------|---------|------|---------|------|
| | | | | | | | |
| | | | | | | | |

* ** * (V) ** * - Tanks Ø 123 - Sheet steel, capacity 1-2-3 liters - Vertical mounting (black painted)

| Capacity | Features | Mounting | Variant (1) | L (mm) | Capacity (liters) | | | Tank (with plug) | Tank fixing kit (screws and O-Ring) |
|----------|----------|----------|-------------|--------|-------------------|------|--------|------------------|-------------------------------------|
| | | | | | Nominal | Full | Usable | | |
| 01 | | | | 141 | 1 | 0.9 | 0.7 | 90310009 | 17010080 |
| 02 | A | (V) | 00 | 200 | 2 | 1.6 | 1.5 | 90310010 | |
| 03 | | | | 330 | 3 | 2.9 | 2.9 | 90310011 | |

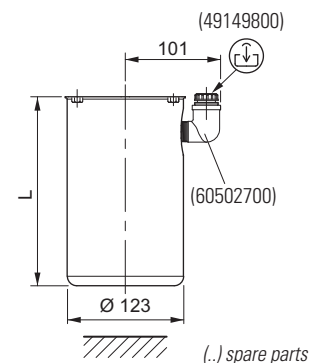

(1) Variant - OMIT if without tank but with tubes kit

Other variants

| Variant | Tank | Variant | Tank | Variant | Tank | Variant | Tank |
|---------|------|---------|------|---------|------|---------|------|
| | | | | | | | |
| | | | | | | | |

Sect. IV - Tanks / Sect. V - Tubes kit

*** ** * (H) ** *** - Tanks Ø 175 - Sheet steel, capacity 5-6-8 liters - Horizontal mounting (black painted)

| Capacity | Features | Mounting | Variant (1) | L (mm) | Capacity (liters) | | | Tank (with plugs) | Tank fixing kit (screws and O-Ring) |
|----------|----------|----------|-------------|--------|-------------------|------|--------|-------------------|-------------------------------------|
| | | | | | Nominal | Full | Usable | | |
| 05 | | | | 246 | 5 | 4.7 | 4.5 | 90310003 | 17010080 |
| 06 | B | (H) | 00 | 308 | 6 | 6 | 5.9 | 90310004 | |
| 08 | | | | 370 | 8 | 8 | 7.3 | 90310005 | |

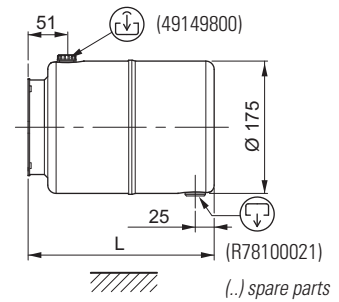

(1) Variant - OMIT if without tank but with tubes kit

Other variants

| Variant | | | | Tank | | | |
|---------|---|-----|----|----------|--|--|--|
| 05 | | | | 90310003 | | | |
| 06 | B | (H) | 01 | | | | |
| 08 | | | | | | | |

| Variant | | | | Tank | | | |
|---------|---|-----|----|----------|--|--|--|
| 05 | | | | 90310149 | | | |
| 06 | B | (H) | 02 | | | | |
| 08 | | | | | | | |

| Variant | | | | Tank | | | |
|---------|---|-----|----|----------|--|--|--|
| 05 | | | | 90310134 | | | |
| 06 | B | (H) | 03 | 90310062 | | | |
| 08 | | | | 90310069 | | | |

| Variant | | | | Tank | | | |
|---------|---|-----|----|----------|--|--|--|
| 05 | | | | 90310176 | | | |
| 06 | B | (H) | 04 | | | | |
| 08 | | | | | | | |

*** ** * (V) ** *** - Tanks Ø 175 - Sheet steel, capacity 5-6-8 liters - Vertical mounting (black painted)

| Capacity | Features | Mounting | Variant (1) | L (mm) | Capacity (liters) | | | Tank (with plugs) | Tank fixing kit (screws and O-Ring) |
|----------|----------|----------|-------------|--------|-------------------|------|--------|-------------------|-------------------------------------|
| | | | | | Nominal | Full | Usable | | |
| 05 | | | | 246 | 5 | 4.3 | 4.1 | 90310012 | 17010080 |
| 06 | B | (V) | 00 | 308 | 6 | 5.8 | 5.5 | 90310013 | |
| 08 | | | | 370 | 8 | 7.5 | 7.2 | 90310015 | |

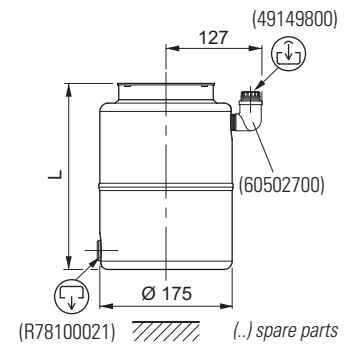

(1) Variant - OMIT if without tank but with tubes kit

Other variants

| Variant | | | | Tank | | | |
|---------|--|--|--|------|--|--|--|
| | | | | | | | |
| | | | | | | | |
| | | | | | | | |

Sect. IV - Tanks / Sect. V - Tubes kit

*** ** * (H) ** *** - Tanks Ø 200 - Sheet steel, capacity 5-8-10 liters - Horizontal mounting (black painted)

| Capacity | Features | Mounting | Variant (1) | L (mm) | Capacity (liters) | | | Tank (with plugs) | Tank fixing kit (screws and O-Ring) |
|----------|----------|----------|-------------|--------|-------------------|------|--------|-------------------|-------------------------------------|
| | | | | | Nominal | Full | Usable | | |
| 05 | | | | 205 | 5 | 5.3 | 5.0 | 90310425 | 17010080 |
| 08 | C | (H) | 00 | 301 | 8 | 8.0 | 7.7 | 90310428 | |
| 10 | | | | 368 | 10 | 10 | 9.3 | 90310431 | |

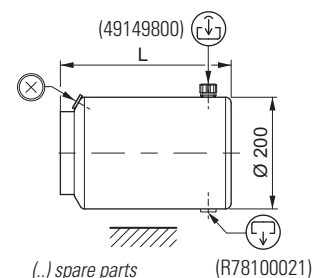

(1) Variant - OMIT if without tank but with tubes kit

Other variants

| Variant | Tank | Variant | Tank | Variant | Tank | Variant | Tank |
|---------|------|---------|------|-------------|----------|---------|------|
| | | | | 05 | 90310453 | | |
| | | | | 08 C (H) 03 | 90310443 | | |
| | | | | 10 | 90310483 | | |

*** ** * (V) ** *** - Tanks Ø 200 - Sheet steel, capacity 5-8-10 liters - Vertical mounting (black painted)

| Capacity | Features | Mounting | Variant (1) | L (mm) | Capacity (liters) | | | Tank (with plugs) | Tank fixing kit (screws and O-Ring) |
|----------|----------|----------|-------------|--------|-------------------|------|--------|-------------------|-------------------------------------|
| | | | | | Nominal | Full | Usable | | |
| 05 | | | | 205 | 5 | 4.6 | 4.3 | 90310444 | 17010080 |
| 08 | C | (V) | 00 | 301 | 8 | 7.5 | 7.1 | 90310437 | |
| 10 | | | | 368 | 10 | 9.5 | 9.1 | 90310439 | |

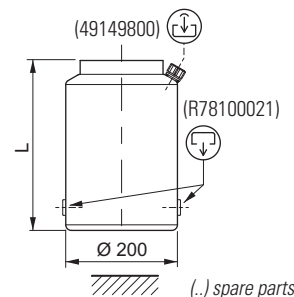

(1) Variant - OMIT if without tank but with tubes kit

Other variants

| Variant | Tank | Variant | Tank | Variant | Tank | Variant | Tank |
|---------|------|---------|------|---------|------|---------|------|
| | | | | | | | |
| | | | | | | | |

Sect. IV - Tanks / Sect. V - Tubes kit

* ** * (H) ** * - Tanks Ø 217 - Sheet steel, capacity 10-12 liters - Horizontal mounting (black painted)

| Capacity | Features | Mounting | Variant (1) | L (mm) | Capacity (liters) | | | Tank (with plugs) | Tank fixing kit (screws and O-Ring) |
|----------|----------|----------|-------------|--------|-------------------|------|--------|-------------------|-------------------------------------|
| | | | | | Nominal | Full | Usable | | |
| 10 | D (H) 00 | | | 273 | 10 | 8 | 7.6 | 90310006 | 17010080 |
| 12 | | | | 370 | 12 | 12 | 11 | 90310058 | |

(1) Variant - OMIT if without tank but with tubes kit

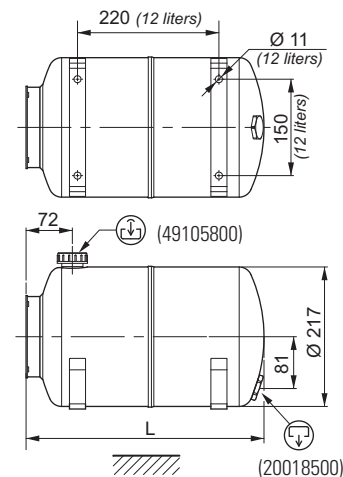

Other variants

(..) spare parts

| Variant | Tank | Variant | Tank | Variant | Tank | Variant | Tank |
|---------|------|---------|------|---------|------|---------|------|
| | | | | | | | |
| | | | | | | | |

* ** * (V) ** * - Tanks Ø 217 - Sheet steel, capacity 10-12 liters - Vertical mounting (black painted)

| Capacity | Features | Mounting | Variant (1) | L (mm) | Capacity (liters) | | | Tank (with plugs) | Tank fixing kit (screws and O-Ring) |
|----------|----------|----------|-------------|--------|-------------------|------|--------|-------------------|-------------------------------------|
| | | | | | Nominal | Full | Usable | | |
| 10 | D (V) 00 | | | 273 | 10 | 7 | 6.8 | 90310029 | 17010080 |
| 12 | | | | 370 | 12 | 10.3 | 10.1 | 90310100 | |

(1) Variant - OMIT if without tank but with tubes kit

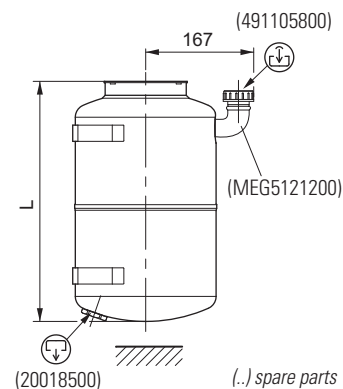

Other variants

| Variant | Tank | Variant | Tank | Variant | Tank | Variant | Tank |
|---------|------|---------|------|---------|------|---------|------|
| | | | | | | | |
| | | | | | | | |

Sect. IV - Tanks / Sect. V - Tubes kit

* ** * (V) ** * - Rectangular tanks - Sheet steel, capacity 7 liters - Vertical mounting (black painted)

| Capacity | Features | Mounting | Variant (1) | L (mm) | Capacity (liters) | | | Tank (with plugs) | Tank fixing kit (screws and O-Ring) |
|----------|----------|----------|-------------|--------|-------------------|------|--------|-------------------|-------------------------------------|
| | | | | | Nominal | Full | Usable | | |
| 07 | E | (V) | 00 | 299 | 7 | 5.5 | 5.1 | 90310014 | 17010080 |

(1) Variant - OMIT if without tank but with tubes kit

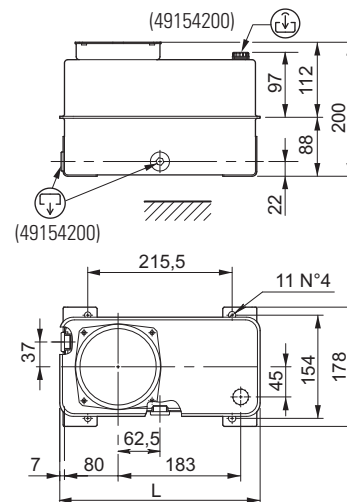

(..) spare parts

Other variants

| Variant | | | | Tank | | | | Variant | | | | Tank | | | | Variant | | | | Tank | | | | | | | | | | |
|---------|---|-----|----|----------|--|--|--|---------|--|--|--|------|--|--|--|---------|--|--|--|------|--|--|--|--|--|--|--|--|--|--|
| 07 | E | (V) | 01 | 90310036 | | | | | | | | | | | | | | | | | | | | | | | | | | |
| | | | | | | | | | | | | | | | | | | | | | | | | | | | | | | |

Sect. IV - Tanks / Sect. V - Tubes kit

* ** * (H) ** * - **Rectangular tanks - Sheet steel, capacity 9 liters - Horizontal mounting (black painted)**

| Capacity | Features | Mounting | Variant (1) | L (mm) | Capacity (liters) | | | Tank (with plugs) | Tank fixing kit (screws and O-Ring) |
|----------|----------|----------|-------------|--------|-------------------|------|--------|-------------------|-------------------------------------|
| | | | | | Nominal | Full | Usable | | |
| 09 | E | (H) | 00 | 350 | 9 | 9 | 8 | 90310142 | 17010080 |

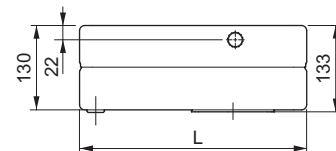
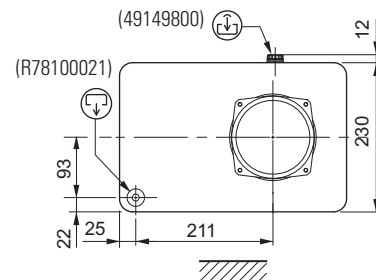

(1) Variant - OMIT if without tank but with tubes kit

(..) spare parts

Other variants

| Variant | Tank | Variant | Tank | Variant | Tank | Variant | Tank |
|---------|------|---------|------|---------|------|---------|------|
| | | | | | | | |
| | | | | | | | |

* ** * (V) ** * - **Rectangular tanks - Sheet steel, capacity 9 liters - Vertical mounting (black painted)**

| Capacity | Features | Mounting | Variant (1) | L (mm) | Capacity (liters) | | | Tank (with plugs) | Tank fixing kit (screws and O-Ring) |
|----------|----------|----------|-------------|--------|-------------------|------|--------|-------------------|-------------------------------------|
| | | | | | Nominal | Full | Usable | | |
| 09 | E | (V) | 00 | 350 | 9 | 8.6 | 7.5 | 90310142 | 17010080 |

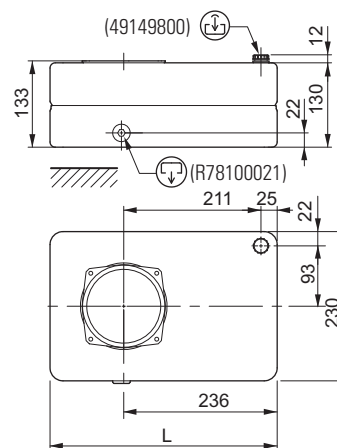

(1) Variant - OMIT if without tank but with tubes kit

(..) spare parts

Other variants

| Variant | Tank | Variant | Tank | Variant | Tank | Variant | Tank |
|---------|------|---------|------|---------|------|---------|------|
| | | | | | | | |
| | | | | | | | |

**IV
V**

Sect. IV - Tanks / Sect. V - Tubes kit

* ** * (*) ** * - Rectangular tanks - Sheet steel, capacity 14 liters - Vertical mounting (black painted)

| Capacity | Features | Mounting | Variant (1) | L (mm) | Capacity (liters) | | | Tank (with plugs) | Tank fixing kit (screws and O-Ring) |
|----------|----------|----------|-------------|--------|-------------------|------|--------|-------------------|-------------------------------------|
| | | | | | Nominal | Full | Usable | | |
| 14 | E | (V) | 00 | 366 | 14 | 14 | 13 | 90310045 | 17010080 |

(1) Variant - OMIT if without tank but with tubes kit

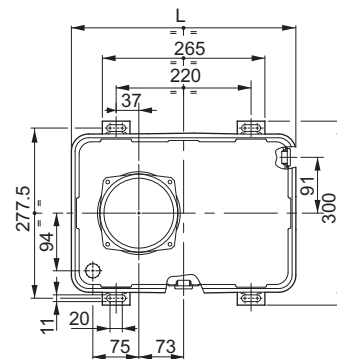
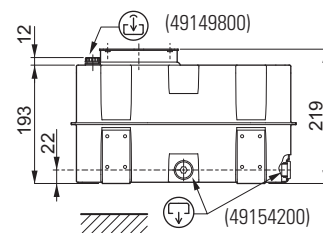

(..) spare parts

Other variants

| Variant | | | | Tank | | | |
|---------|---|-----|----|----------|--|--|--|
| 14 | E | (V) | 01 | 90310046 | | | |
| | | | | | | | |
| | | | | | | | |

Sect. IV - Tanks / Sect. V - Tubes kit

* ** * (*) ** * - **Rectangular tanks - Sheet steel, capacity 25 liters - Horizontal mounting (black painted)**

| Capacity | Features | Mounting | Variant (1) | L (mm) | Capacity (liters) | | | Tank (with plugs) | Tank fixing kit (screws and O-Ring) |
|----------|----------|----------|-------------|--------|-------------------|------|--------|-------------------|-------------------------------------|
| | | | | | Nominal | Full | Usable | | |
| 25 | E | (H) | 00 | 436 | 25 | 22 | 21 | 90310060 | 17010080 |

(1) Variant - OMIT if without tank but with tubes kit

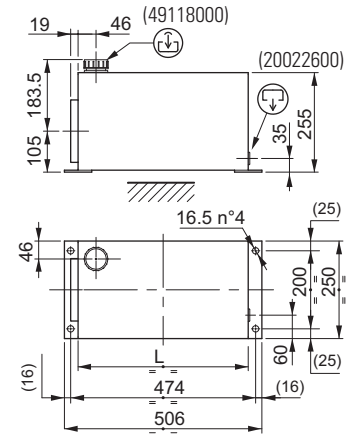

(..) spare parts

Other variants

| Variant | Tank | Variant | Tank | Variant | Tank | Variant | Tank |
|-------------|----------|---------|------|---------|------|---------|------|
| 25 E (H) 01 | 90310083 | | | | | | |

* ** * (*) ** * - **Rectangular tanks - Sheet steel, capacity 25 liters - Vertical mounting (black painted)**

| Capacity | Features | Mounting | Variant (1) | L (mm) | Capacity (liters) | | | Tank (with plugs) | Tank fixing kit (screws and O-Ring) |
|----------|----------|----------|-------------|--------|-------------------|------|--------|-------------------|-------------------------------------|
| | | | | | Nominal | Full | Usable | | |
| 25 | E | (V) | 00 | 436 | 25 | 25 | 22 | 90310071 | 17010080 |

(1) Variant - OMIT if without tank but with tubes kit

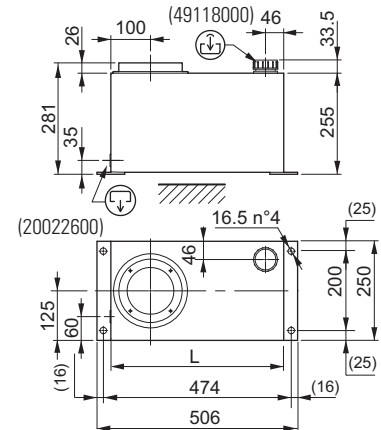

(..) spare parts

Other variants

| Variant | Tank | Variant | Tank | Variant | Tank | Variant | Tank |
|-------------|----------|---------|------|---------|------|---------|------|
| 25 E (V) 01 | 90310124 | | | | | | |

Sect. IV - Tanks / Sect. V - Tubes kit

*** ** * (H) ** *** - **Square polypropylene tanks capacity 5-7 liters - Horizontal mounting**

| Capacity | Features | Mounting | Variant (1) | L (mm) | Capacity (liters) | | | Tank (with plug, brackets, nuts) | Tank fixing kit (screws and O-Ring) |
|----------|----------|----------|-------------|--------|-------------------|------|--------|----------------------------------|-------------------------------------|
| | | | | | Nominal | Full | Usable | | |
| 05 | F (H) 00 | | | 242 | 5 | 5.4 | 4.5 | 90310313 | 17010083 |
| 07 | | | | 306 | 7 | 7.4 | 6.5 | 90310289 | |

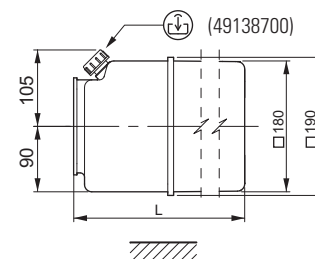

Operating temperature -10°C ÷ +60°C - (1) Variant - OMIT if without tank but with tubes kit

(..) spare parts

Other variants

| Variant | Tank | Variant | Tank | Variant | Tank | Variant | Tank |
|---------|------|---------|------|---------|------|---------|------|
| | | | | | | | |

*** ** * (V) ** *** - **Square polypropylene tanks capacity 5-7 liters - Vertical mounting**

| Capacity | Features | Mounting | Variant (1) | L (mm) | Capacity (liters) | | | Tank (with plug, brackets, nuts) | Tank fixing kit (screws and O-Ring) |
|----------|----------|----------|-------------|--------|-------------------|------|--------|----------------------------------|-------------------------------------|
| | | | | | Nominal | Full | Usable | | |
| 05 | F (V) 00 | | | 242 | 5 | 5.4 | 4.5 | 90310313 | 17010083 |
| 07 | | | | 306 | 7 | 7.4 | 6.5 | 90310289 | |

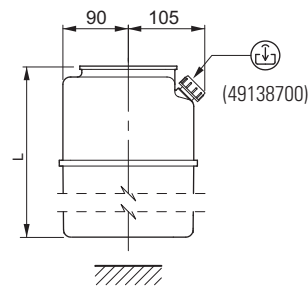

Operating temperature -10°C ÷ +60°C - (1) Variant - OMIT if without tank but with tubes kit

(..) spare parts

Other variants

| Variant | Tank | Variant | Tank | Variant | Tank | Variant | Tank |
|---------|------|---------|------|---------|------|---------|------|
| | | | | | | | |

Sect. IV - Tanks / Sect. V - Tubes kit

*** ** * (H) ** *** - **Square polyethylene tanks capacity 1.5-2.5-4 liters - Horizontal mounting**

| Capacity | Features | Mounting | Variant (1) | L (mm) | Capacity (liters) | | | Tank (with plugs, clamp, nuts) | Tank fixing kit (screws and O-Ring) |
|----------|----------|----------|-------------|--------|-------------------|------|--------|--------------------------------|-------------------------------------|
| | | | | | Nominal | Full | Usable | | |
| 02 | | | | 135 | 1.5 | 1.3 | 1 | 90310491 | 17010081 |
| 03 | G | (H) | 00 | 235 | 2.5 | 2.5 | 2 | 90310484 | |
| 04 | | | | 295 | 4 | 3.4 | 2.5 | 90310422 | |

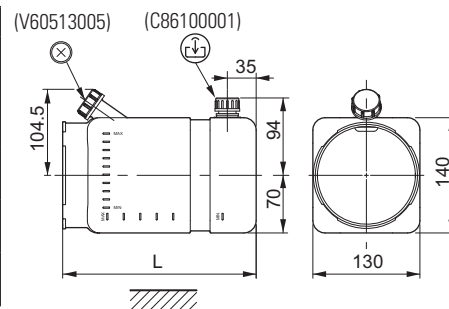

Operating temperature -10°C ÷ +70°C - (1) Variant - OMIT if without tank but with tubes kit

(..) spare parts

Other variants

| Variant | Tank | Variant | Tank | Variant | Tank | Variant | Tank |
|---------|------|---------|------|---------|------|---------|------|
| | | | | | | | |
| | | | | | | | |

*** ** * (V) ** *** - **Square polyethylene tanks capacity 1.5-2.5-4 liters - Vertical mounting**

| Capacity | Features | Mounting | Variant (1) | L (mm) | Capacity (liters) | | | Tank (with plugs, clamp, nuts) | Tank fixing kit (screws and O-Ring) |
|----------|----------|----------|-------------|--------|-------------------|------|--------|--------------------------------|-------------------------------------|
| | | | | | Nominal | Full | Usable | | |
| 02 | | | | 135 | 1.5 | 1.1 | 0.7 | 90310486 | 17010081 |
| 03 | G | (V) | 00 | 235 | 2.5 | 2.7 | 2.3 | 90310419 | |
| 04 | | | | 296 | 4 | 3.5 | 3.1 | 90310402 | |

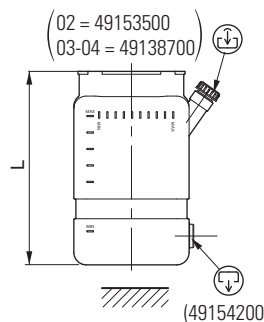

Operating temperature -10°C ÷ +70°C - (1) Variant - OMIT if without tank but with tubes kit

(..) spare parts

Other variants

| Variant | Tank | Variant | Tank | Variant | Tank | Variant | Tank |
|---------|------|---------|------|---------|------|---------|------|
| | | | | | | | |
| | | | | | | | |

**IV
V**

Sect. IV - Tanks / Sect. V - Tubes kit

*** ** * (H) ** *** - **Square polyethylene tanks capacity 4 liters - Horizontal mounting**

| Capacity | Features | Mounting | Variant (1) | L (mm) | Capacity (liters) | | | Tank (with plugs, clamp, nuts) | Tank fixing kit (screws and O-Ring) |
|----------|----------|----------|-------------|--------|-------------------|------|--------|--------------------------------|-------------------------------------|
| | | | | | Nominal | Full | Usable | | |
| 04 | L | (H) | 00 | 210 | 4 | 3.6 | 3 | 90310331 | 17010081 |

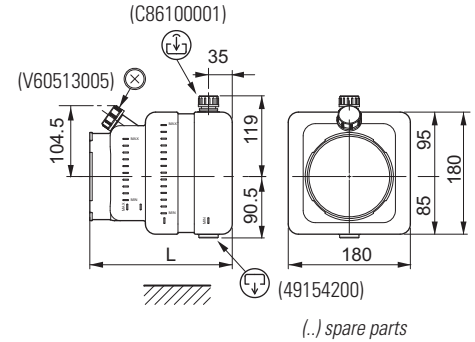

Operating temperature -10°C ÷ +70°C - (1) Variant - OMIT if without tank but with tubes kit

Other variants

| Variant | Tank | Variant | Tank | Variant | Tank | Variant | Tank |
|---------|------|---------|------|---------|------|---------|------|
| | | | | | | | |

*** ** * (V) ** *** - **Square polyethylene tanks capacity 4 liters - Vertical mounting**

| Capacity | Features | Mounting | Variant (1) | L (mm) | Capacity (liters) | | | Tank (with plugs, clamp, nuts) | Tank fixing kit (screws and O-Ring) |
|----------|----------|----------|-------------|--------|-------------------|------|--------|--------------------------------|-------------------------------------|
| | | | | | Nominal | Full | Usable | | |
| 04 | L | (V) | 00 | 210 | 4 | 3.7 | 3 | 90310332 | 17010081 |

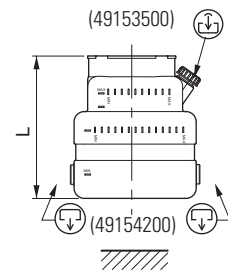

Operating temperature -10°C ÷ +70°C - (1) Variant - OMIT if without tank but with tubes kit

(..) spare parts

Other variants

| Variant | Tank | Variant | Tank | Variant | Tank | Variant | Tank |
|-------------|----------|---------|------|---------|------|---------|------|
| 04 L (V) 01 | 90310433 | | | | | | |

*** ** * (*) ** *** - **Square polyethylene tanks capacity 7-10 liters - Horizontal mounting**

| Capacity | Features | Mounting | Variant (1) | L (mm) | Capacity (liters) | | | Tank (with plugs, clamp, nuts) | Tank fixing kit (screws and O-Ring) |
|----------|----------|----------|-------------|--------|-------------------|------|--------|--------------------------------|-------------------------------------|
| | | | | | Nominal | Full | Usable | | |
| 07 | L (H) 00 | | | 310 | 7 | 6.7 | 5.5 | 90310330 | 17010081 |
| 10 | | | | 410 | 10 | 8.7 | 7.5 | 90310339 | |

Operating temperature -10°C ÷ +70°C - (1) Variant - OMIT if without tank but with tubes kit

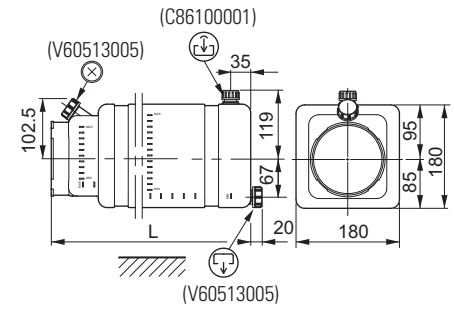

(..) spare parts

*** ** * (*) ** *** - **Square polyethylene tanks capacity 7-10 liters - Vertical mounting**

| Capacity | Features | Mounting | Variant (1) | L (mm) | Capacity (liters) | | | Tank (with plugs, clamp, nuts) | Tank fixing kit (screws and O-Ring) |
|----------|----------|----------|-------------|--------|-------------------|------|--------|--------------------------------|-------------------------------------|
| | | | | | Nominal | Full | Usable | | |
| 07 | L (V) 00 | | | 310 | 7 | 6.7 | 6 | 90310403 | 17010081 |
| 10 | | | | 410 | 10 | 9.8 | 9 | 90310338 | |

Operating temperature -10°C ÷ +70°C - (1) Variant - OMIT if without tank but with tubes kit

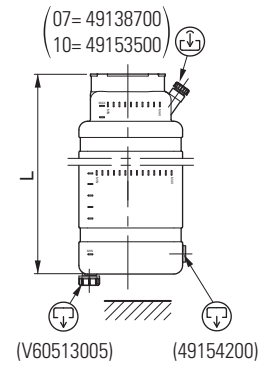

(..) spare parts

*** ** * (*) ** *** - **Square polyethylene tanks capacity 9 liters - Vertical mounting**

| Capacity | Features | Mounting | Variant (1) | L (mm) | Capacity (liters) | | | Tank (with plugs, clamp, nuts) | Tank fixing kit collar Ø123 (screws and O-Ring) |
|----------|----------|----------|-------------|--------|-------------------|------|--------|--------------------------------|---|
| | | | | | Nominal | Full | Usable | | |
| 09 | L (V) 00 | | | 390 | 9 | 8.6 | 8 | 90310371 | 17010081 |

Operating temperature -10°C ÷ +70°C - (1) Variant - OMIT if without tank but with tubes kit

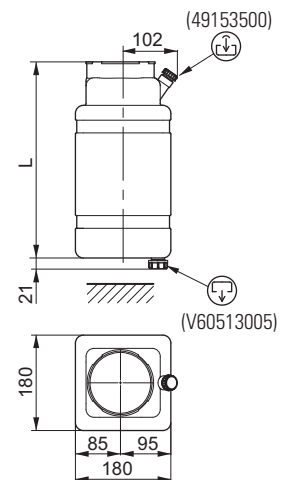

(..) spare parts

Sect. IV - Tanks / Sect. V - Tubes kit

*** ** * (H) ** *** - **Special square polyethylene tanks capacity 7 liters - Horizontal mounting**

| Capacity | Features | Mounting | Variant (1) | L (mm) | Capacity (liters) | | | Tank (with plugs, clamp, nuts) | Tank fixing kit (screws and O-Ring) |
|----------|----------|----------|-------------|--------|-------------------|------|--------|--------------------------------|-------------------------------------|
| | | | | | Nominal | Full | Usable | | |
| 07 | M | (H) | 00 | 335 | 7 | 7.3 | 6.6 | 90310380 | 17010081 |

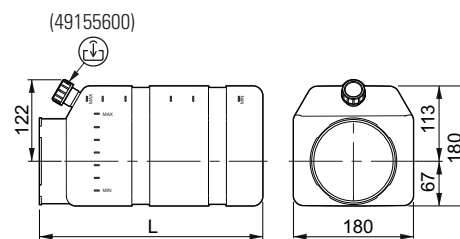

Operating temperature -10°C ÷ +70°C - (1) Variant - OMIT if without tank but with tubes kit

(..) spare parts

Other variants

| Variant | | | | Tank | | | | Variant | | | | Tank | | | | Variant | | | | Tank | | | |
|---------|--|--|--|------|--|--|--|---------|--|--|--|------|--|--|--|---------|--|--|--|------|--|--|--|
| | | | | | | | | | | | | | | | | | | | | | | | |

*** ** * (V) ** *** - **Special square polyethylene tanks capacity 7 liters - Vertical mounting**

| Capacity | Features | Mounting | Variant (1) | L (mm) | Capacity (liters) | | | Tank (with plugs, clamp, nuts) | Tank fixing kit (screws and O-Ring) |
|----------|----------|----------|-------------|--------|-------------------|------|--------|--------------------------------|-------------------------------------|
| | | | | | Nominal | Full | Usable | | |
| 07 | M | (V) | 00 | 335 | 7 | 7.2 | 6.4 | 90310380 | 17010081 |

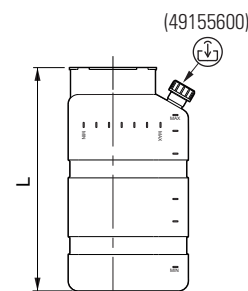

Operating temperature -10°C ÷ +70°C - (1) Variant - OMIT if without tank but with tubes kit

(..) spare parts

Other variants

| Variant | | | | Tank | | | | Variant | | | | Tank | | | | Variant | | | | Tank | | | |
|---------|--|--|--|------|--|--|--|---------|--|--|--|------|--|--|--|---------|--|--|--|------|--|--|--|
| | | | | | | | | | | | | | | | | | | | | | | | |

Sect. IV - Tanks / Sect. V - Tubes kit

* ** * (*) ** /* - Tanks orientation according to the mounting position

| For tanks | | | (*) | Mounting position | /* Orientation | | | |
|-----------|----|------------------|-----|-------------------|----------------|----|----|----|
| S | ** | A B C D | | | /1 (standard) | /2 | /3 | /4 |
| | | | (H) | | (1) | | | |

| For tanks | | | (*) | Mounting position | /* Orientation | | | |
|-----------|----|---|-----|-------------------|----------------|--|--|--|
| S | 09 | E | | | /1 (standard) | | | |
| | | | (H) | | | | | |

| For tanks | | | (*) | Mounting position | /* Orientation | | | |
|-----------|----|---|-----|-------------------|----------------|--|--|--|
| S | 25 | E | | | /1 (standard) | | | |
| | | | (H) | | | | | |

| For tanks | | | (*) | Mounting position | /* Orientation | | | |
|-----------|----|-------------|-----|-------------------|----------------|----|----|----|
| S | ** | F G L | | | /1 (standard) | /2 | /3 | /4 |
| | | | (H) | | (1) | | | |

(1) Orientation TO BE USED with blocks

IV
V

Sect. IV - Tanks / Sect. V - Tubes kit

* ** * (*) ** /* - Tanks orientation according to the mounting position

| For tanks | | | (*) | Mounting position | /* Orientation | | | |
|-----------|----|---------------------------------|-----|-------------------|----------------|----|----|----|
| | | | (V) | Vertical | /1 (standard) | /2 | /3 | /4 |
| S | ** | A B C D F G L | (V) | | | | | |
| | | | | | (2) | | | |

| For tanks | | | (*) | Mounting position | /* Orientation | | | |
|-----------|----|---|-----|-------------------|----------------|----|----|----|
| | | | (V) | Vertical | /1 (standard) | /2 | /3 | /4 |
| S | 07 | E | (V) | | | | | |
| | | | | | (1) | | | |

| For tanks | | | (*) | Mounting position | /* Orientation | | | |
|-----------|----------|---|-----|-------------------|----------------|----|----|----|
| | | | (V) | Vertical | /1 (standard) | /2 | /3 | /4 |
| S | 09 25 | E | (V) | | | | | |
| | | | | | (1) | | | |

| For tanks | | | (*) | Mounting position | /* Orientation | | | |
|-----------|----|---|-----|-------------------|----------------|----|----|----|
| | | | (V) | Vertical | /1 (standard) | /2 | /3 | /4 |
| S | 14 | E | (V) | | | | | |
| | | | | | (1) | | | |

(1) Orientation TO BE USED with blocks
 (2) DO NOT USE with blocks

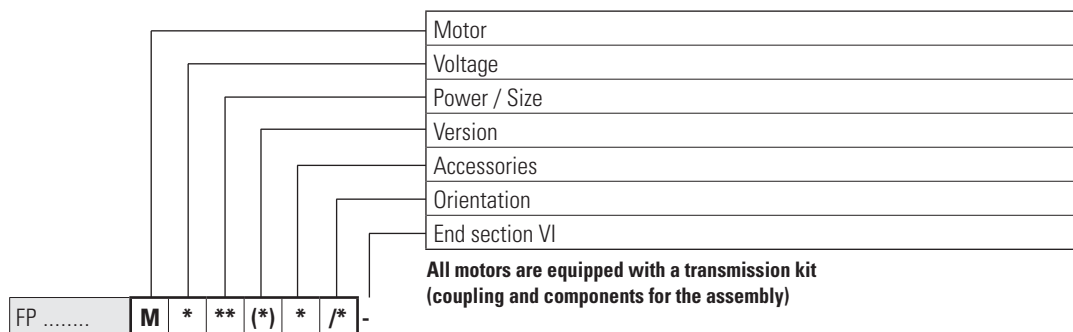

All motors are equipped with a transmission kit (coupling and components for the assembly)

| * | Voltage | ** | Power | Size | (*) | Version | Page | * Accessories | /* Orientation | Page |
|---|---------|----|--------|-------|-----|---------|------|---------------------------|--------------------------|------|
| 2 | 12 VDC | GA | 350 W | Ø 80 | (1) | Std | 72 | 0 - B | /1 /2 Std /3 /4 | 76 |
| | | GC | 700 W | Ø 80 | (1) | Std | 72 | 0 - B | | |
| | | AA | 1500 W | Ø 115 | (1) | Std | 73 | 0 - B - C - D - F - G - H | | |
| | | EN | 1600 W | Ø 115 | (1) | Std | 73 | 0 - B - C - E | | |
| | | GN | 1600 W | Ø 115 | (1) | Std | 74 | 0 - B - C - E | | |
| 4 | 24 VDC | GB | 400 W | Ø 80 | (1) | Std | 72 | 0 - B | | |
| | | GD | 800 W | Ø 80 | (1) | Std | 72 | 0 - B | | |
| | | AB | 2000 W | Ø 115 | (1) | Std | 73 | 0 - B - C - D - F - G - H | | |
| | | ES | 2200 W | Ø 115 | (1) | Std | 73 | 0 - B - C - E | | |
| | | GP | 2200 W | Ø 115 | (1) | Std | 74 | 0 - B - C - E | | |
| | | GJ | 3000 W | Ø 125 | (1) | Std | 74 | 0 - B - C - E | | |
| | | FB | 3000 W | Ø 125 | (1) | Std | 74 | 0 - B - C - E | | |

| * | Accessories description | Page |
|-------|--|------|
| 0 | Without accessories | — |
| B | Starting switch | 75 |
| C | Thermal protection | — |
| D (•) | Ventilation | 75 |
| E | Starting switch + thermal protection | — |
| F (•) | Starting switch + ventilation | — |
| G | Thermal protection + ventilation | — |
| H (•) | Starting switch + thermal protection + ventilation | — |

(•) = IP protection level becomes effective after installation on power pack. Acquires IP 10 level with "ventilation" accessory.

For more details, features and performances DC motors, see catalog code DOC00053.

Motors: 12 VDC 350 W / 24 VDC 400 W (permanent magnets)

| | Voltage | W | A | rpm | Nm | S2 min | S3% | IP | IC | Ø mm | Code (⊗) |
|------------------------|---------|-----|----|------|-----|--------|-----|----|----|------|----------|
| M 2 GA (1) * /* | 12 VDC | 350 | 40 | 3300 | 1.0 | 10 | 35 | 54 | F | 80 | 25021400 |
| M 4 GB (1) * /* | 24 VDC | 400 | 30 | 3100 | 1.2 | 5 | 20 | 54 | F | 80 | 25021500 |

IP protection level becomes effective after installation on power pack.
 (⊗) Motor without accessories

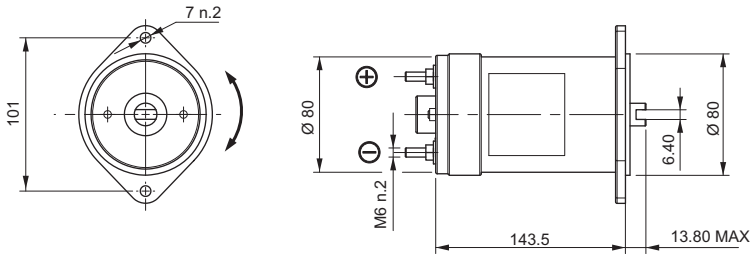

M * ** (*) * /* - Accessories (page 75)

| * Description |
|---|
| 0 Without accessories |
| B Starting switch 120A fixing with clamp |

Code trasmission kit: page 83

Motors: 12 VDC 700 W / 24 VDC 800 W (permanent magnets)

| | Voltage | W | A | rpm | Nm | S2 min | S3% | IP | IC | Ø mm | Code (⊗) |
|------------------------|---------|-----|----|------|-----|--------|-----|----|----|------|----------|
| M 2 GC (1) * /* | 12 VDC | 700 | 90 | 3300 | 2.0 | 2.5 | 10 | 54 | F | 80 | 25021600 |
| M 4 GD (1) * /* | 24 VDC | 800 | 70 | 3000 | 2.5 | 2 | 5 | 54 | F | 80 | 25021700 |

IP protection level becomes effective after installation on power pack.
 (⊗) Motor without accessories

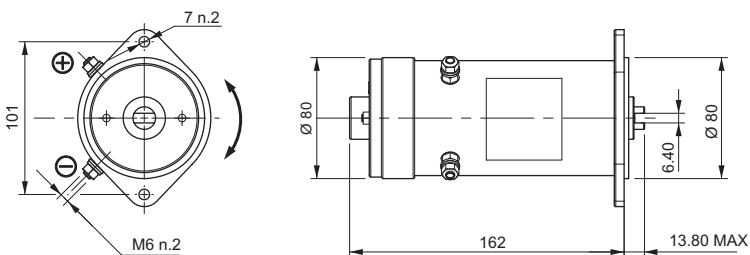

M * ** (*) * /* - Accessories (page 75)

| * Description |
|-------------------------------|
| 0 Without accessories |
| B Starting switch 120A |

Code trasmission kit: page 83

For more details, features and performances DC motors, see catalog code DOC00053.

Motors: 12 VDC 1500 W / 24 VDC 2000 W (wound field compound)

| | Voltage | W | A | rpm | Nm | S2 min | S3% | IP | IC | Ø mm | Code (⊗) |
|------------------------|---------|------|-----|------|-----|--------|-----|----|----|------|----------|
| M 2 AA (1) * /* | 12 VDC | 1500 | 225 | 2500 | 5.5 | 1 | 5 | 54 | F | 115 | 25022200 |
| M 4 AB (1) * /* | 24 VDC | 2000 | 150 | 2250 | 8 | 2 | 5 | 54 | F | 115 | 25022300 |

IP protection level becomes effective after installation on power pack.
 (⊗) Motor without accessories

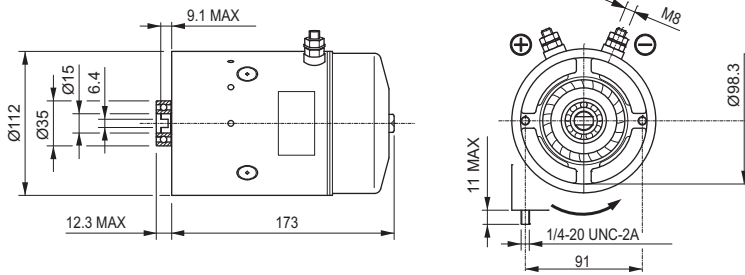

Code trasmission kit: page 83

M * ** (*) * /* - Accessories (page 75)

| * Description |
|---|
| 0 Without accessories |
| B Starting switch 120A |
| D Ventilation |
| F Ventilation + Starting switch |
| G Ventilation + Thermal protection |
| H Ventilation + Thermal protection + Starting switch |

Acquires IP 10 protection level with "ventilation" accessory.

Motors: 12 VDC 1600 W / 24 VDC 2200 W (wound field compound)

| | Voltage | W | A | rpm | Nm | S2 min | S3% | IP | IC | Ø mm | Code (⊗) |
|------------------------|---------|------|-----|------|----|--------|-----|----|----|------|----------|
| M 2 EN (1) * /* | 12 VDC | 1600 | 230 | 2600 | 5 | 2 | 10 | 54 | F | 115 | 25021100 |
| M 4 ES (1) * /* | 24 VDC | 2200 | 140 | 2700 | 8 | 1.2 | 5 | 54 | F | 115 | 25021200 |

IP protection level becomes effective after installation on power pack.
 (⊗) Motor without accessories

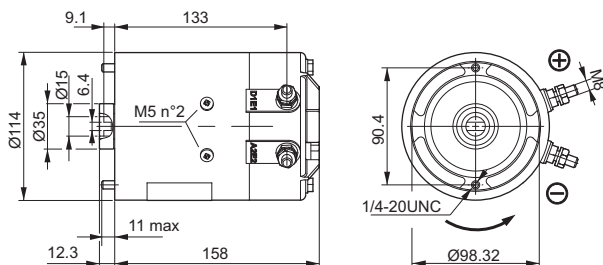

Code trasmission kit: page 83

M * ** (*) * /* - Accessories (page 75)

| * Description |
|---|
| 0 Without accessories |
| B Starting switch 120A |
| C Thermal protection |
| E Starting switch + thermal protection |

Motors: 12 VDC 1600 W / 24 VDC 2200 W (wound field serie)

| | Voltage | W | A | rpm | Nm | S2 min | S3% | IP | IC | Ø mm | Code (⊗) |
|-----------------|---------|------|-----|------|----|--------|-----|----|----|------|----------|
| M 2 GN (1) * /* | 12 VDC | 1600 | 220 | 2600 | 6 | 4 | 8 | 54 | F | 115 | 25022600 |
| M 4 GP (1) * /* | 24 VDC | 2200 | 140 | 2600 | 6 | 2 | 7.5 | 54 | F | 115 | 25022700 |

IP protection level becomes effective after installation on power pack.
 (⊗) Motor without accessories

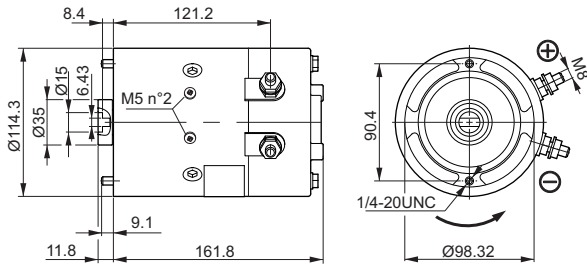

M * ** (*) * /* - Accessories (page 75)

| * | Description |
|---|----------------------|
| 0 | Without accessories |
| B | Starting switch 120A |

Code trasmission kit: page 83

Motors: 24 VDC 3000 W (wound field compound)

| | Voltage | W | A | rpm | Nm | S2 min | S3% | IP | IC | Ø mm | Code (⊗) |
|-----------------|---------|------|-----|------|-----|--------|-----|----|----|------|----------|
| M 4 FB (1) * /* | 24 VDC | 3000 | 200 | 3300 | 8.5 | 4 | 15 | 20 | F | 125 | 25021300 |
| M 4 GJ (1) * /* | 24 VDC | 3000 | 180 | 3500 | 8.5 | 3.5 | 15 | 20 | F | 125 | 25022400 |

IP protection level becomes effective after installation on power pack.
 (⊗) Motor without accessories

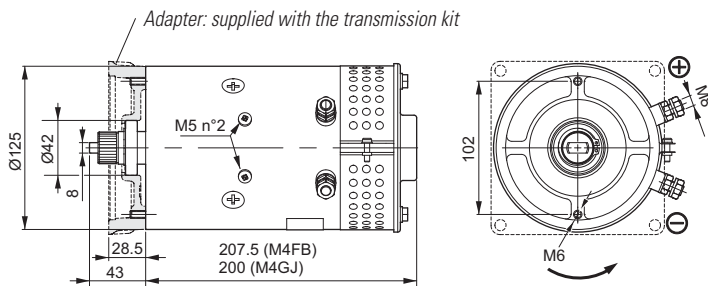

M * ** (*) * /* - Accessories (page 75)

| ** | * | Description |
|----------|---|--|
| FB GJ | 0 | Without accessories |
| | B | Starting switch 150A |
| | D | Ventilation |
| | F | Ventilation + Starting switch |
| FB | G | Ventilation + Thermal protection |
| | H | Ventilation + Thermal protection + Starting switch |

Code trasmission kit: page 83

For more details, features and performances DC motors, see catalog code DOC00053.

M * ** (*) **C** /* - **Accessory: Thermal protection**

| Thermal protection | | |
|--------------------|------|-------------|
| Code | Ø mm | For motors |
| 90340009 | 16 | M2EN - M4ES |

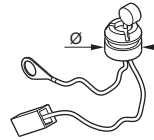

M * ** (*) **B** /* - **Accessory: Starting switch**

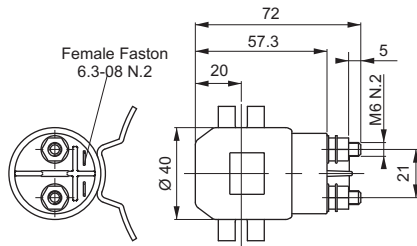

| 120A starting switch | | |
|----------------------|-----|-------------|
| Code (•) | VDC | For motors |
| KIT07012.027 | 12 | M2GA - M2GC |
| KIT07012.032 | 24 | M4GB - M4GD |
| KIT07012.033 | 12 | M2AA |
| KIT07012.034 | 24 | M4AB |
| KIT07012.025 | 12 | M2EN - M2GN |
| KIT07012.026 | 24 | M4ES - M2GP |

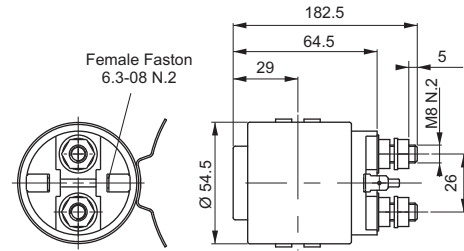

| 150A starting switch | | |
|----------------------|-----|-------------|
| Code (•) | VDC | For motors |
| KIT07012.019 | 24 | M4FB - M4GJ |

(•) Complete kit with all assembly components.

For more details, features and performances DC motors, see catalog ode DOC00053.

M * ** (*) ***** /* - **Accessory: Ventilation (motor included)**

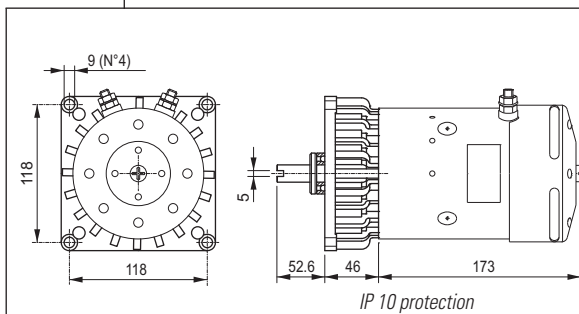

| * | Code (•) | VDC | For motors |
|---|--------------|-----|---------------------------|
| D | KIT09008.061 | 12 | M2AA |
| G | KIT09008.062 | 12 | M2AA + thermal protection |
| D | KIT09008.031 | 24 | M4AB |
| G | KIT09008.063 | 24 | M4AB + thermal protection |

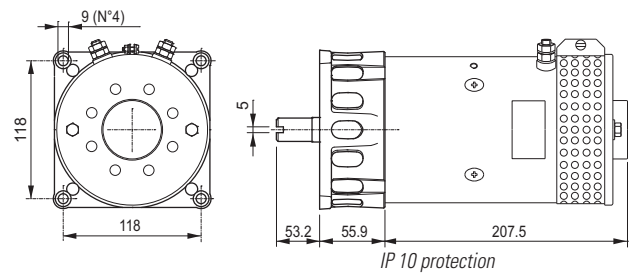

| * | Code (•) | VDC | For motors |
|---|--------------|-----|------------|
| D | KIT09008.029 | 24 | M4FB |

(•) Complete kit with all assembly components (motor, transmission kit, etc).

For more details, features and performances DC motors, see catalog code DOC00053.

M * ** (*) * /* - Motor orientation

Starting switch and poles position.

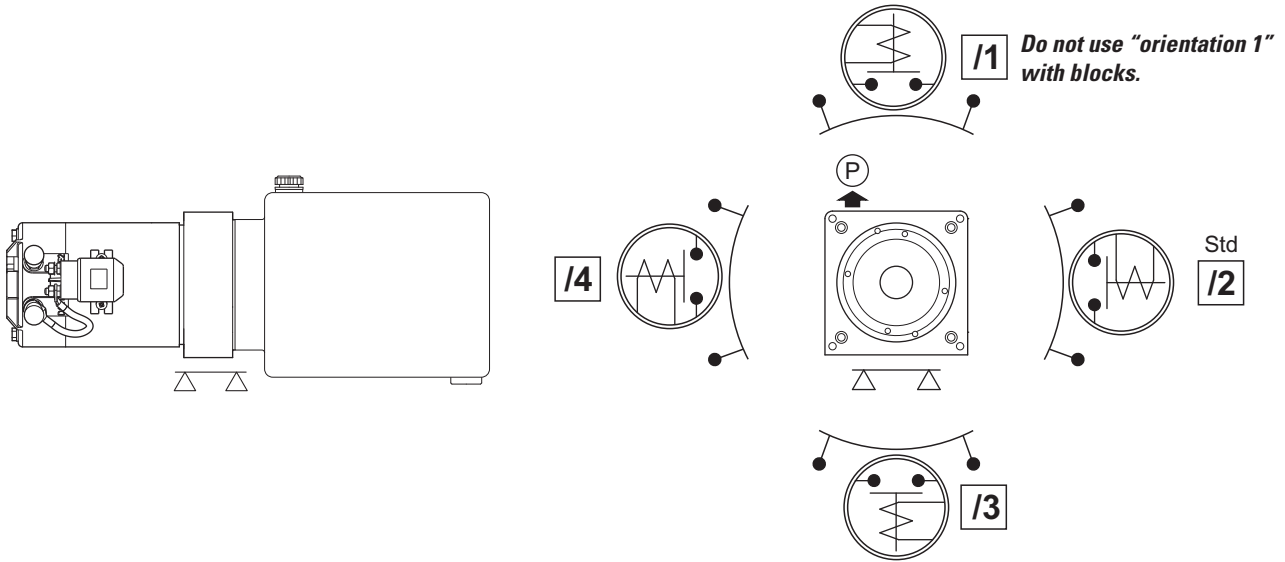

Sect. VI - AC Motors

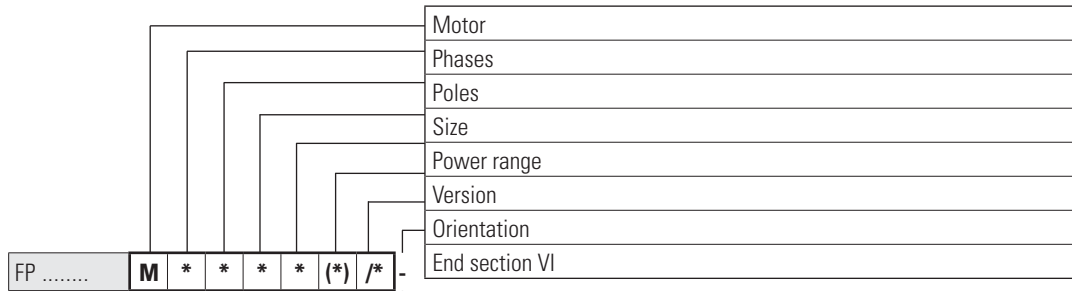

| * Phases | * Poles | * Size | * Power range | | Page | (*) Version | /* Orientation | Page | |
|--------------------------|-------------------------|------------------|------------------|-------------------|-------------------|----------------|--------------------------|------|----|
| | | | Power | Voltage | | | | | |
| M Single-phase | 2 | L 71 | A 0.37 | 230 Vac 50 Hz | 78 | (1) Std | /1 /2 /3 /4 Std | 82 | |
| | | L 71 | B 0.55 | 230 Vac 50 Hz | 78 | | | | |
| | | S 71 | A 0.75 kW | 230 Vac 50 Hz | 80 | | | | |
| | | S 71 | B 1.10 kW | 230 Vac 50 Hz | 80 | | | | |
| | | M 80 | A 0.75 | 230 Vac 50 Hz | 78 | | | | |
| | | M 80 | B 1.10 | 230 Vac 50 Hz | 78 | | | | |
| | | N 90 | A 1.50 | 230 Vac 50 Hz | 78 | | | | |
| | | N 90 | B 2.20 | 230 Vac 50 Hz | 78 | | | | |
| | | P 100 | A 3.00 | 230 Vac 50 Hz | 78 | | | | |
| | | L 71 | A 0.25 | 230 Vac 50 Hz | 78 | | | | |
| | | L 71 | B 0.37 | 230 Vac 50 Hz | 78 | | | | |
| | | S 71 | C 0.85 kW | 230 Vac 50 Hz | 80 | | | | |
| | M 80 | A 0.55 | 230 Vac 50 Hz | 78 | | | | | |
| | M 80 | B 0.75 | 230 Vac 50 Hz | 78 | | | | | |
| | N 90 | A 1.10 | 230 Vac 50 Hz | 78 | | | | | |
| | N 90 | B 1.50 | 230 Vac 50 Hz | 78 | | | | | |
| | V 90 | A 1.80 kW | 230 Vac 50 Hz | 81 | | | | | |
| | V 90 | B 3.00 kW | 230 Vac 50 Hz | 81 | | | | | |
| | P 100 | A 2.20 | 230 Vac 50 Hz | 78 | | | | | |
| | T Three-phase | 2 | R 63 | A 0.18 kW | 230/400 Vac 50 Hz | | | | 79 |
| | | | R 63 | B 0.25 kW | 230/400 Vac 50 Hz | | | | 79 |
| | | | L 71 | A 0.37 kW | 230/400 Vac 50 Hz | | | | 79 |
| | | | L 71 | B 0.55 kW | 230/400 Vac 50 Hz | | | | 79 |
| | | | S 71 | A 0.75 kW | 230/400 Vac 50 Hz | | | | 80 |
| S 71 | | | B 1.10 kW | 230/400 Vac 50 Hz | 80 | | | | |
| M 80 | | | A 0.75 kW | 230/400 Vac 50 Hz | 79 | | | | |
| M 80 | | | B 1.10 kW | 230/400 Vac 50 Hz | 79 | | | | |
| T 80 | | | A 2.70 kW | 230/400 Vac 50 Hz | 81 | | | | |
| T 80 | | | B 2.70 kW | 230/400 Vac 50 Hz | 81 | | | | |
| N 90 | | | A 1.50 kW | 230/400 Vac 50 Hz | 79 | | | | |
| N 90 | | | B 2.20 kW | 230/400 Vac 50 Hz | 79 | | | | |
| P 100 | | | A 3.00 kW | 230/400 Vac 50 Hz | 79 | | | | |
| P 112 | | | B 4.00 kW | 230/400 Vac 50 Hz | 79 | | | | |
| R 63 | | | A 0.12 kW | 230/400 Vac 50 Hz | 79 | | | | |
| R 63 | | | B 0.18 kW | 230/400 Vac 50 Hz | 79 | | | | |
| 4 | | | L 71 | A 0.25 kW | 230/400 Vac 50 Hz | 79 | | | |
| | | | L 71 | B 0.37 kW | 230/400 Vac 50 Hz | 79 | | | |
| | | S 71 | A 0.75 kW | 230/400 Vac 50 Hz | 80 | | | | |
| | | M 80 | A 0.55 kW | 230/400 Vac 50 Hz | 79 | | | | |
| | | M 80 | B 0.75 kW | 230/400 Vac 50 Hz | 79 | | | | |
| | | T 80 | A 2.20 kW | 230/400 Vac 50 Hz | 81 | | | | |
| | | T 80 | B 2.20 kW | 230/400 Vac 50 Hz | 81 | | | | |
| | | T 80 | C 2.20 kW | 230/400 Vac 50 Hz | 81 | | | | |
| | | T 80 | D 3.00 kW | 230/400 Vac 50 Hz | 81 | | | | |
| | | N 90 | A 1.10 kW | 230/400 Vac 50 Hz | 79 | | | | |
| | | N 90 | B 1.50 kW | 230/400 Vac 50 Hz | 79 | | | | |
| | | P 100 | A 2.20 kW | 230/400 Vac 50 Hz | 79 | | | | |
| | | P 100 | B 3.00 kW | 230/400 Vac 50 Hz | 79 | | | | |
| | | P 112 | C 4.00 kW | 230/400 Vac 50 Hz | 79 | | | | |

Motors supplied with all assembly components (transmission kit, coupling, etc).

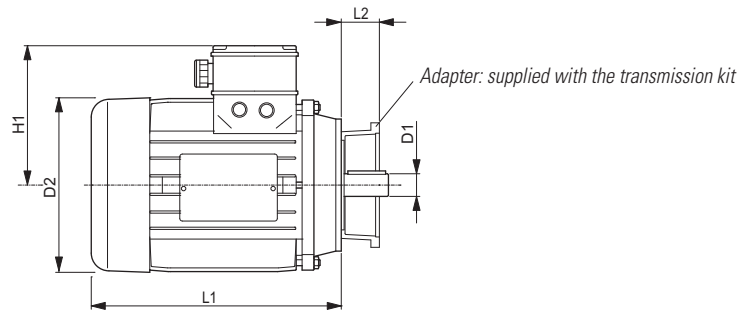

Single-phase motors 2-4 Poles - 230 Vac 50Hz - Version B14

| M | M | Poles | Size | D1 (•) | D2 (•) | H1 (•) | L1 (•) | Power range | | | | | Cable gland metric thread | Adapter | | | Single Motor | Transmission kit (for pump) | | | | | |
|---|---|-------|------|--------|--------|--------|--------|-------------|---------|-----|-----|-----|---------------------------|---------------|----------------|----|--------------|-----------------------------|----------|-------|------|----------|---|
| | | | | | | | | Power kW | Voltage | IP | IC | S1 | | Code | Screw UNI 5931 | L2 | | | | | | | |
| M | M | 2 | L | A | (1) | 2 | 2 | 71 | 14 | 148 | 115 | 208 | 0.37 | 230 Vac 50 Hz | 54 | F | Si | 20-25 | 61000700 | M6x20 | 19.5 | M12E2000 | KIT08019.011 (Gr.05) |
| M | M | 2 | L | B | (1) | 2 | 2 | 71 | 14 | 148 | 115 | 208 | 0.55 | 230 Vac 50 Hz | 54 | F | Si | 20-25 | 61000700 | M6x20 | 19.5 | M12F2000 | KIT08019.012 (Gr.1) |
| M | M | 2 | M | A | (1) | 2 | 2 | 80 | 19 | 170 | 126 | 234 | 0.75 | 230 Vac 50 Hz | 54 | F | Si | 20-25 | 61000800 | M6x20 | 30.4 | M13G2000 | KIT08019.013 (Gr.05) |
| M | M | 2 | M | B | (1) | 2 | 2 | 80 | 19 | 170 | 126 | 234 | 1.10 | 230 Vac 50 Hz | 54 | F | Si | 20-25 | 61000800 | M6x20 | 30.4 | M13H2000 | KIT08019.014 (Gr.1) |
| M | M | 2 | N | A | (1) | 2 | 2 | 90 | 24 | 185 | 142 | 247 | 1.50 | 230 Vac 50 Hz | 54 | F | Si | 20-25 | 61000900 | M8x21 | 40.4 | M14L2000 | KIT08019.015 (Gr.05) |
| M | M | 2 | N | B | (1) | 2 | 2 | 90 | 24 | 185 | 142 | 272 | 2.20 | 230 Vac 50 Hz | 54 | F | Si | 20-25 | 61000900 | M8x21 | 40.4 | M14N2000 | KIT08019.016 (Gr.1) |
| M | M | 2 | P | A | (1) | 2 | 2 | 100 | 28 | 210 | 155 | 310 | 3.00 | 230 Vac 50 Hz | 54 | F | Si | 25-32 | 61001000 | M8x28 | 75 | M15P2000 | KIT08019.017 (Gr.05) KIT08019.018 (Gr.1) |
| M | M | 4 | L | A | (1) | 2 | 4 | 71 | 14 | 148 | 115 | 208 | 0.25 | 230 Vac 50 Hz | 54 | F | Si | 20-25 | 61000700 | M6x20 | 19.5 | M12D4000 | KIT08019.011 (Gr.05) |
| M | M | 4 | L | B | (1) | 2 | 4 | 71 | 14 | 148 | 115 | 208 | 0.37 | 230 Vac 50 Hz | 54 | F | Si | 20-25 | 61000700 | M6x20 | 19.5 | M12E4000 | KIT08019.012 (Gr.1) |
| M | M | 4 | M | A | (1) | 2 | 4 | 80 | 19 | 170 | 126 | 234 | 0.55 | 230 Vac 50 Hz | 54 | F | Si | 20-25 | 61000800 | M6x20 | 30.4 | M13F4000 | KIT08019.013 (Gr.05) |
| M | M | 4 | M | B | (1) | 2 | 4 | 80 | 19 | 170 | 126 | 234 | 0.75 | 230 Vac 50 Hz | 54 | F | Si | 20-25 | 61000800 | M6x20 | 30.4 | M13G4000 | KIT08019.014 (Gr.1) |
| M | M | 4 | N | A | (1) | 2 | 4 | 90 | 24 | 185 | 142 | 247 | 1.10 | 230 Vac 50 Hz | 54 | F | Si | 20-25 | 61000900 | M8x21 | 40.4 | M14H4000 | KIT08019.015 (Gr.05) |
| M | M | 4 | N | B | (1) | 2 | 4 | 90 | 24 | 185 | 142 | 272 | 1.50 | 230 Vac 50 Hz | 54 | F | Si | 20-25 | 61000900 | M8x21 | 40.4 | M14L4000 | KIT08019.016 (Gr.1) |
| M | M | 4 | P | A | (1) | 2 | 4 | 100 | 28 | 210 | 155 | 310 | 2.20 | 230 Vac 50 Hz | 54 | F | Si | 25-32 | 61001000 | M8x28 | 75 | M15N4000 | KIT08019.017 (Gr.05) KIT08019.018 (Gr.1) |

(•) = Approximate dimensions

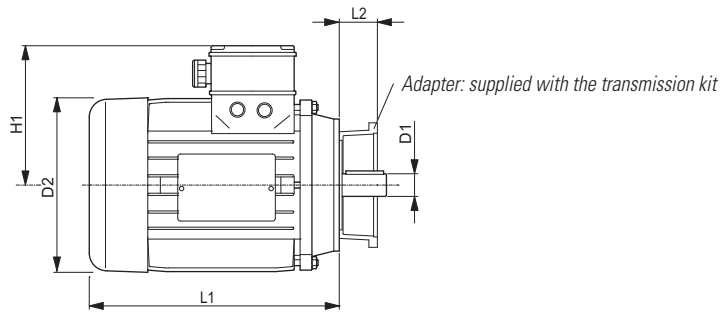

Three-phase motors 2-4 Poles - 230/400 Vac 50Hz - Version B14

| M | T | Poles | Size | D1 (•) | D2 (•) | H1 (•) | L1 (•) | Power range | | | | | Cable gland metric thread | Adapter | | | Single Motor | Transmission kit (for pump) | | | | | |
|---|---|-------|------|--------|--------|--------|--------|-------------|---------|-----|-----|-----|---------------------------|-------------------|----------------|----|--------------|-----------------------------|----------|-------|------|----------|----------------------|
| | | | | | | | | Power kW | Voltage | IP | IC | S3 | | Code | Screw UNI 5931 | L2 | | | | | | | |
| M | T | 2 | R | A | (1) | 3 | 2 | 63 | 11 | 125 | 95 | 189 | 0.18 | 230/400 Vac 50 Hz | 54 | F | 60% | 16-20 | 61004300 | M5x16 | 19.5 | M31C2000 | KIT08019.009 (Gr.05) |
| M | T | 2 | R | B | (1) | 3 | 2 | 63 | 11 | 125 | 95 | 189 | 0.25 | 230/400 Vac 50 Hz | 54 | F | 60% | 16-20 | 61004300 | M5x16 | 19.5 | M31D2000 | KIT08019.010 (Gr.1) |
| M | T | 2 | L | A | (1) | 3 | 2 | 71 | 14 | 148 | 115 | 208 | 0.37 | 230/400 Vac 50 Hz | 54 | F | 60% | 20-25 | 61000700 | M6x20 | 19.5 | M32E2000 | KIT08019.011 (Gr.05) |
| M | T | 2 | L | B | (1) | 3 | 2 | 71 | 14 | 148 | 115 | 208 | 0.55 | 230/400 Vac 50 Hz | 54 | F | 60% | 20-25 | 61000700 | M6x20 | 19.5 | M32F2000 | KIT08019.012 (Gr.1) |
| M | T | 2 | M | A | (1) | 3 | 2 | 80 | 19 | 170 | 126 | 234 | 0.75 | 230/400 Vac 50 Hz | 54 | F | 60% | 20-25 | 61000800 | M6x20 | 30.4 | M33G2000 | KIT08019.013 (Gr.05) |
| M | T | 2 | M | B | (1) | 3 | 2 | 80 | 19 | 170 | 126 | 234 | 1.10 | 230/400 Vac 50 Hz | 54 | F | 60% | 20-25 | 61000800 | M6x20 | 30.4 | M33H2000 | KIT08019.014 (Gr.1) |
| M | T | 2 | N | A | (1) | 3 | 2 | 90 | 24 | 185 | 142 | 247 | 1.50 | 230/400 Vac 50 Hz | 54 | F | 60% | 20-25 | 61000900 | M8x21 | 40.4 | M34L2000 | KIT08019.015 (Gr.05) |
| M | T | 2 | N | B | (1) | 3 | 2 | 90 | 24 | 185 | 142 | 272 | 2.20 | 230/400 Vac 50 Hz | 54 | F | 60% | 20-25 | 61000900 | M8x21 | 40.4 | M34N2000 | KIT08019.016 (Gr.1) |
| M | T | 2 | P | A | (1) | 3 | 2 | 100 | 28 | 210 | 155 | 310 | 3.00 | 230/400 Vac 50 Hz | 54 | F | 60% | 25-32 | 61001000 | M8x28 | 75 | M35P2000 | KIT08019.017 (Gr.05) |
| M | T | 2 | P | B | (1) | 3 | 2 | 112 | 28 | 225 | 182 | 325 | 4.00 | 230/400 Vac 50 Hz | 54 | F | 60% | 25-32 | 61001000 | M8x28 | 75 | M36Q2000 | KIT08019.018 (Gr.1) |
| M | T | 4 | R | A | (1) | 3 | 4 | 63 | 11 | 125 | 95 | 189 | 0.12 | 230/400 Vac 50 Hz | 54 | F | 60% | 16-20 | 61004300 | M5x16 | 19.5 | M31B4000 | KIT08019.009 (Gr.05) |
| M | T | 4 | R | B | (1) | 3 | 4 | 63 | 11 | 125 | 95 | 189 | 0.18 | 230/400 Vac 50 Hz | 54 | F | 60% | 16-20 | 61004300 | M5x16 | 19.5 | M31C4000 | KIT08019.010 (Gr.1) |
| M | T | 4 | L | A | (1) | 3 | 4 | 71 | 14 | 148 | 115 | 208 | 0.25 | 230/400 Vac 50 Hz | 54 | F | 60% | 20-25 | 61000700 | M6x20 | 19.5 | M32D4000 | KIT08019.011 (Gr.05) |
| M | T | 4 | L | B | (1) | 3 | 4 | 71 | 14 | 148 | 115 | 208 | 0.37 | 230/400 Vac 50 Hz | 54 | F | 60% | 20-25 | 61000700 | M6x20 | 19.5 | M32E4000 | KIT08019.012 (Gr.1) |
| M | T | 4 | M | A | (1) | 3 | 4 | 80 | 19 | 170 | 126 | 234 | 0.55 | 230/400 Vac 50 Hz | 54 | F | 60% | 20-25 | 61000800 | M6x20 | 30.4 | M33F4000 | KIT08019.013 (Gr.05) |
| M | T | 4 | M | B | (1) | 3 | 4 | 80 | 19 | 170 | 126 | 234 | 0.75 | 230/400 Vac 50 Hz | 54 | F | 60% | 20-25 | 61000800 | M6x20 | 30.4 | M33G4000 | KIT08019.014 (Gr.1) |
| M | T | 4 | N | A | (1) | 3 | 4 | 90 | 24 | 185 | 142 | 247 | 1.10 | 230/400 Vac 50 Hz | 54 | F | 60% | 20-25 | 61000900 | M8x21 | 40.4 | M34H4000 | KIT08019.015 (Gr.05) |
| M | T | 4 | N | B | (1) | 3 | 4 | 90 | 24 | 185 | 142 | 272 | 1.50 | 230/400 Vac 50 Hz | 54 | F | 60% | 20-25 | 61000900 | M8x21 | 40.4 | M34L4000 | KIT08019.016 (Gr.1) |
| M | T | 4 | P | A | (1) | 3 | 4 | 100 | 28 | 210 | 155 | 310 | 2.20 | 230/400 Vac 50 Hz | 54 | F | 60% | 25-32 | 61001000 | M8x28 | 75 | M35N4000 | KIT08019.017 (Gr.05) |
| M | T | 4 | P | B | (1) | 3 | 4 | 100 | 28 | 210 | 155 | 310 | 3.00 | 230/400 Vac 50 Hz | 54 | F | 60% | 25-32 | 61001000 | M8x28 | 75 | M35P4000 | KIT08019.018 (Gr.1) |
| M | T | 4 | P | C | (1) | 3 | 4 | 112 | 28 | 225 | 182 | 325 | 4.00 | 230/400 Vac 50 Hz | 54 | F | 60% | 25-32 | 61001000 | M8x28 | 75 | M36Q4000 | |

(•) = Approximate dimensions

VI
AC

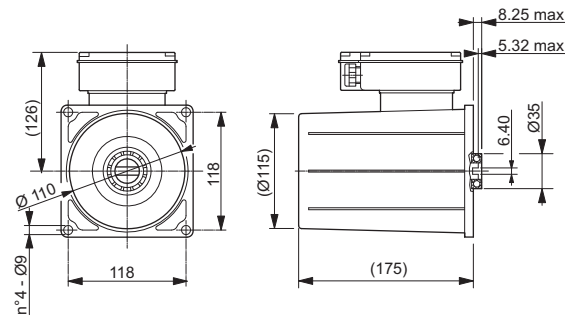

Single-phase motors 2-4 Poles - 230 Vac 50Hz - Special housing

| Phases | Poles | Size | Power range | | | | Cable gland metric thread | Single Motor | Transmission kit | Note | |
|--------|-------------|--------|-------------|---------------|----|----|---------------------------|--------------|------------------|--|-------------|
| | | | Power kW | Voltage | IP | IC | | | | | Service |
| M | M 2 S A (1) | 2 2 71 | 0.75 | 230 Vac 50 Hz | 54 | F | Light-duty | 20 | M12GY3FF.001 | KIT08019.005 (for Gr.0.5 pumps) KIT08019.006 (for Gr.1 pumps) | Without fan |
| M | M 2 S B (1) | 2 2 71 | 1.10 | 230 Vac 50 Hz | 54 | F | Light-duty | 20 | M12HY3FF.000 | KIT08019.005 (for Gr.0.5 pumps) KIT08019.006 (for Gr.1 pumps) | Without fan |
| M | M 4 S C (1) | 2 4 71 | 0.85 | 230 Vac 50 Hz | 54 | F | Light-duty | 20 | M12YY3FF.001 | KIT08019.005 (for Gr.0.5 pumps) KIT08019.006 (for Gr.1 pumps) | Without fan |

IP protection level becomes effective after installation on power pack.

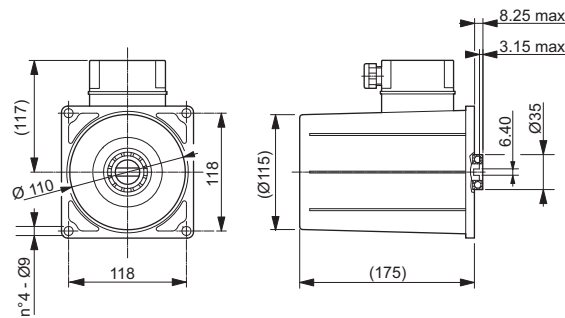

Three-phase motors 2-4 Poles - 230/400 Vac 50Hz - Direct fixing

| Phases | Poles | Size | Power range | | | | Cable gland metric thread | Single Motor | Transmission kit | Note | |
|--------|-------------|--------|-------------|-------------------|----|----|---------------------------|--------------|------------------|--|-------------|
| | | | Power kW | Voltage | IP | IC | | | | | Service |
| M | T 2 S A (1) | 3 2 71 | 0.75 | 230/400 Vac 50 Hz | 54 | F | Light-duty | 20 | M32GY3FL.003 | KIT08019.005 (for Gr.0.5 pumps) KIT08019.006 (for Gr.1 pumps) | Without fan |
| M | T 2 S B (1) | 3 2 71 | 1.10 | 230/400 Vac 50 Hz | 54 | F | Light-duty | 20 | M32HY3FL.001 | KIT08019.005 (for Gr.0.5 pumps) KIT08019.006 (for Gr.1 pumps) | Without fan |
| M | T 4 S A (1) | 3 4 71 | 0.75 | 230/400 Vac 50 Hz | 54 | F | Light-duty | 20 | M32GY3FL.002 | KIT08019.005 (for Gr.0.5 pumps) KIT08019.006 (for Gr.1 pumps) | Without fan |

IP protection level becomes effective after installation on power pack.

With fan

Without fan

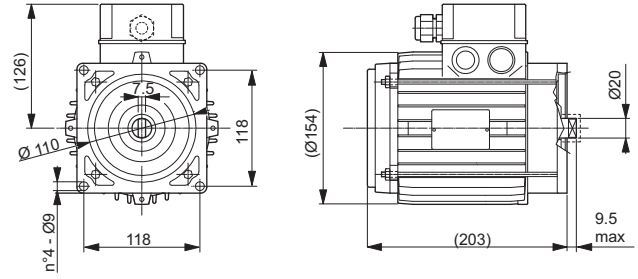
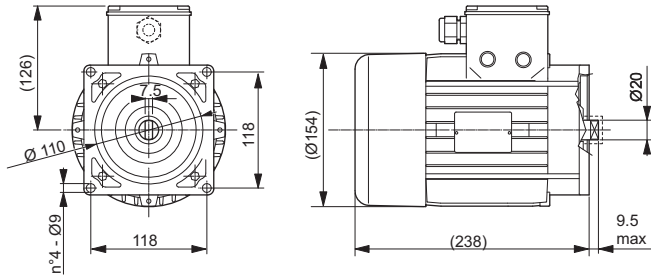

Three-phase motors 2-4 Poles - 230/400 Vac 50Hz - Direct fixing

| M | T | Poles | Size | Power range | | | | Cable gland metric thread | Single Motor | Transmission kit | Note | | | | |
|---|---|-------|-------|-------------|---------|----|-----|------------------------------|--------------|------------------|------------|---------|--------------|--|-------------|
| | | | | Power kW | Voltage | IP | IC | | | | | Service | | | |
| M | T | 2 | A (1) | 3 | 2 | 80 | 2.7 | 230/400 Vac 50 Hz | 44 | F | Light-duty | 20-25 | M33YD1FF.000 | KIT08019.007 (for Gr.0.5 pumps) KIT08019.008 (for Gr.1 pumps) | With fan |
| M | T | 2 | B (1) | 3 | 2 | 80 | 2.7 | 230/400 Vac 50 Hz | 44 | F | Light-duty | 20-25 | M33YD1FF.001 | KIT08019.007 (for Gr.0.5 pumps) KIT08019.008 (for Gr.1 pumps) | Without fan |
| M | T | 4 | A (1) | 3 | 4 | 80 | 2.2 | 230/400 Vac 50 Hz | 44 | F | S3 - 4% | 20-25 | M33NF1FF.001 | KIT08019.007 (for Gr.0.5 pumps) KIT08019.008 (for Gr.1 pumps) | Without fan |
| M | T | 4 | B (1) | 3 | 4 | 80 | 2.2 | 230/400 Vac 50 Hz | 55 | F | S3 - 4% | 20-25 | M33NF4FF.000 | KIT08019.007 (for Gr.0.5 pumps) KIT08019.008 (for Gr.1 pumps) | With fan |
| M | T | 4 | C (1) | 3 | 4 | 80 | 2.2 | 230/400 Vac 50 Hz | 44 | F | S3 - 4% | 20-25 | M33NF1FF.000 | KIT08019.007 (for Gr.0.5 pumps) KIT08019.008 (for Gr.1 pumps) | With fan |
| M | T | 4 | D (1) | 3 | 4 | 80 | 3.0 | 230/400 Vac 50 Hz | 54 | F | Light-duty | 20-25 | M33PF3FF.000 | KIT08019.007 (for Gr.0.5 pumps) KIT08019.008 (for Gr.1 pumps) | With fan |

IP protection level becomes effective after installation on power pack.

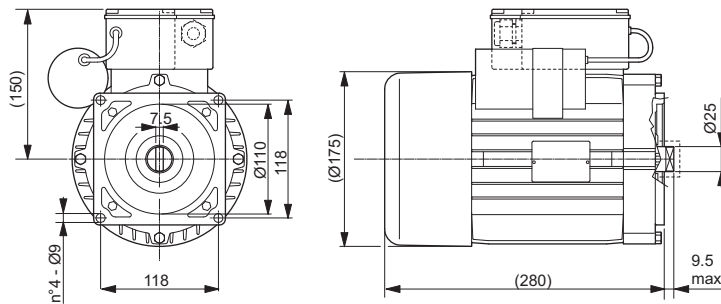

Single-phase motors 4 Poles - 230 Vac 50Hz - Direct fixing

| M | T | Poles | Size | Power range | | | | Cable gland metric thread | Single Motor | Transmission kit | Note | | | | |
|---|---|-------|---------|-------------|---------|----|-----|------------------------------|--------------|------------------|------------|---------|--------------|--|-------------------------------|
| | | | | Power kW | Voltage | IP | IC | | | | | Service | | | |
| M | M | 4 | V A (1) | 2 | 4 | 90 | 1.8 | 230 Vac 50 Hz | 44 | F | Light-duty | 20-25 | M14MF1FF.001 | KIT08019.007 (for Gr.0.5 pumps) KIT08019.008 (for Gr.1 pumps) | With fan Start torque 13Nm |
| M | M | 4 | V B (1) | 2 | 4 | 90 | 3.0 | 230 Vac 50 Hz | 55 | F | S3 - 7% | 20-25 | M14PF4FF.000 | KIT08019.007 (for Gr.0.5 pumps) KIT08019.008 (for Gr.1 pumps) | With fan |

IP protection level becomes effective after installation on power pack.

M * * * * (*) / * - Motor orientation

Connector box position on power pack.

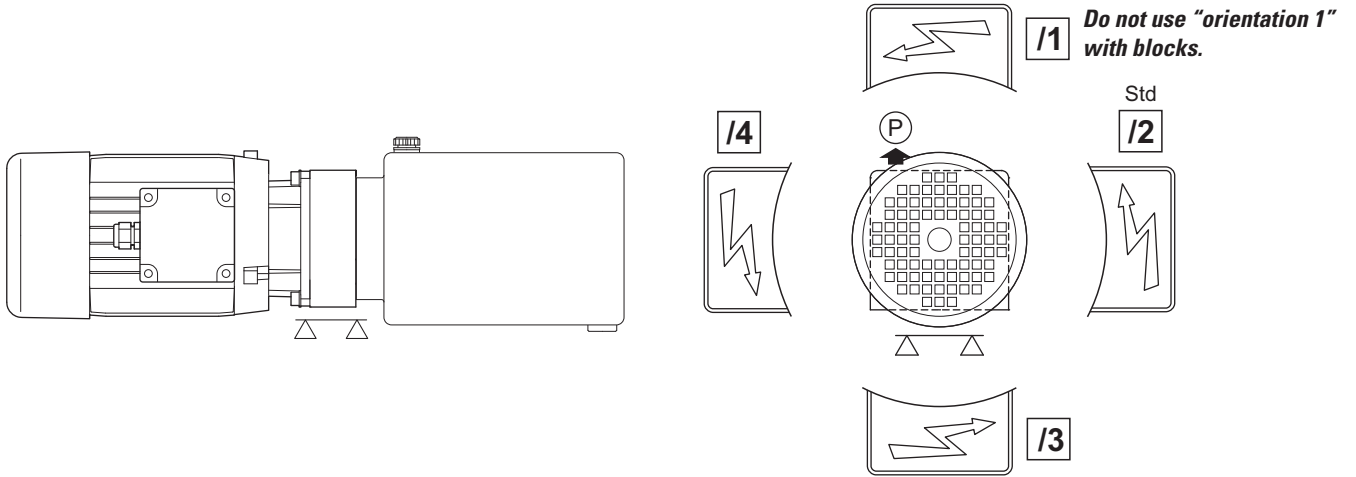

Sect. VII - Transmission kit

| |
|---|
| Transmission kit (only for motors on the catalog) |
| Type |
| End section VII |

Specify the transmission kit whether you requested the joint and accessories assembly (without motor).

FP **T** ******

| ** | Transmission kit | | | | For DC motors |
|----|---------------------|---------|------|----|--|
| | Code | Pump | L | Ø | |
| 01 | KIT08019.000 | Gr. 0.5 | 63.3 | 14 | GA (350 W - Ø 80 - Pag. 72) GC (700 W - Ø 80 - Pag. 72) GB (400 W - Ø 80 - Pag. 72) GD (800 W - Ø 80 - Pag. 72) |
| | KIT08019.001 | Gr. 1 | 46.9 | 14 | |

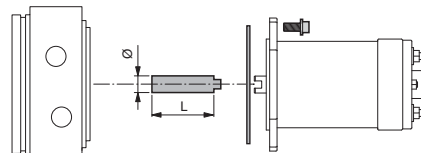

| ** | Transmission kit | | | | For DC motors |
|----|---------------------|---------|------|----|--|
| | Code | Pump | L | Ø | |
| 02 | KIT08019.002 | Gr. 0.5 | 64.5 | 14 | AA (1500 W - Ø 115 - Pag. 73) EN (1600 W - Ø 115 - Pag. 73) AB (2000 W - Ø 115 - Pag. 73) ES (2200 W - Ø 115 - Pag. 73) GN (1600 W - Ø 115 - Pag. 74) GP (2200 W - Ø 115 - Pag. 74) |
| | KIT08019.003 | Gr. 1 | 48.2 | 14 | |

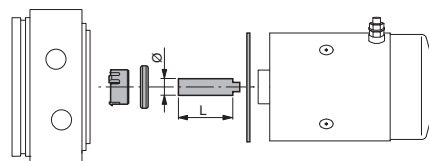

| ** | Transmission kit | | | | For DC motors |
|----|---------------------|-------|------|----|--|
| | Code | Pump | L | Ø | |
| 03 | KIT08019.004 | Gr. 1 | 45.4 | 20 | GJ (3000 W - Ø 125 - Pag. 74) FB (3000 W - Ø 125 - Pag. 74) |

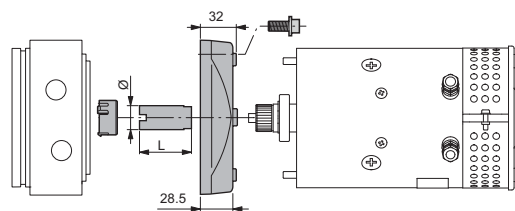

Note: in ventilated motors (accessory "D" page 74) the transmission is included in the kit ventilation

Sect. VII - Transmission kit

Transmission kit (only for motors on the catalog)
Type
End section VII

Specify the transmission kit whether you requested the joint and accessories assembly (without motor).

FP T **

| ** | Transmission kit | | | | | | For AC motors | | |
|----|------------------|---------|------|----|----|------|---------------|-------------|------|
| | Code | Pump | L | Ø | L1 | Z | Ref. | Size | Page |
| 1R | KIT08019.009 | Gr. 0.5 | 47.1 | 14 | 30 | 62.7 | R | 63 (B14) | 79 |
| | KIT08019.010 | Gr. 1 | 30.6 | 20 | 30 | 42.8 | | | |

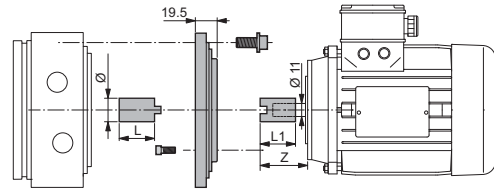

| ** | Transmission kit | | | | | | For AC motors | | |
|----|------------------|---------|------|----|------|----|---------------|-------------|------|
| | Code | Pump | L | Ø | L1 | Z | Ref. | Size | Page |
| 1L | KIT08019.011 | Gr. 0.5 | 47.1 | 14 | 26.5 | 42 | L | 71 (B14) | 78 |
| | KIT08019.012 | Gr. 1 | 30.7 | 20 | 26.5 | 42 | | | 79 |

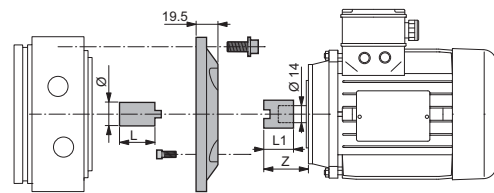

| ** | Transmission kit | | | | | | For AC motors | | |
|----|------------------|---------|------|----|----|----|---------------|-------------|------|
| | Code | Pump | L | Ø | L1 | Z | Ref. | Size | Page |
| 1M | KIT08019.013 | Gr. 0.5 | 47.1 | 14 | 38 | 53 | M | 80 (B14) | 78 |
| | KIT08019.014 | Gr. 1 | 30.7 | 20 | 38 | 53 | | | 79 |

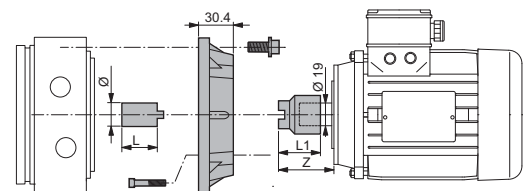

| ** | Transmission kit | | | | | | For AC motors | | |
|----|------------------|---------|------|----|------|----|---------------|-------------|------|
| | Code | Pump | L | Ø | L1 | Z | Ref. | Size | Page |
| 1N | KIT08019.015 | Gr. 0.5 | 47.1 | 14 | 45.4 | 63 | N | 90 (B14) | 78 |
| | KIT08019.016 | Gr. 1 | 30.7 | 20 | 45.4 | 63 | | | 79 |

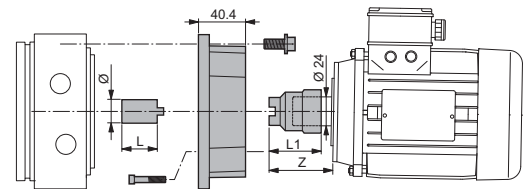

| ** | Transmission kit | | | | | | For AC motors | | |
|----|------------------|---------|------|-------|----|------|---------------|------------------|------|
| | Code | Pump | L | Ø | L1 | Z | Ref. | Size | Page |
| 1P | KIT08019.017 | Gr. 0.5 | 62.9 | 14/20 | 57 | 81.5 | P | 100-112 (B14) | 78 |
| | KIT08019.018 | Gr. 1 | 46.6 | 20 | 57 | 81.5 | | | 79 |

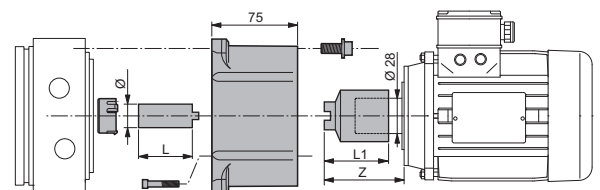

| ** | Transmission kit | | | | For AC motors | | |
|----|------------------|---------|------|----|---------------|-----------------------|------|
| | Code | Pump | L | Ø | Ref. | Size | Page |
| 1S | KIT08019.005 | Gr. 0.5 | 64.5 | 14 | S | 71 (direct fixing) | 80 |
| | KIT08019.006 | Gr. 1 | 48.2 | 14 | | | |

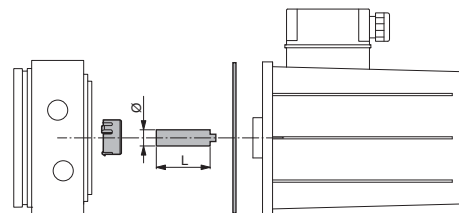

| ** | Transmission kit | | | | For AC motors | | |
|----|------------------|---------|------|----|---------------|--------------------------|------|
| | Code | Pump | L | Ø | Ref. | Size | Page |
| 1T | KIT08019.007 | Gr. 0.5 | 68 | 14 | T V | 80-90 (direct fixing) | 81 |
| | KIT08019.008 | Gr. 1 | 51.7 | 20 | | | |

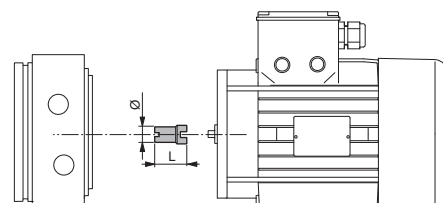

"Z" : dimension of the coupling side motor

VII

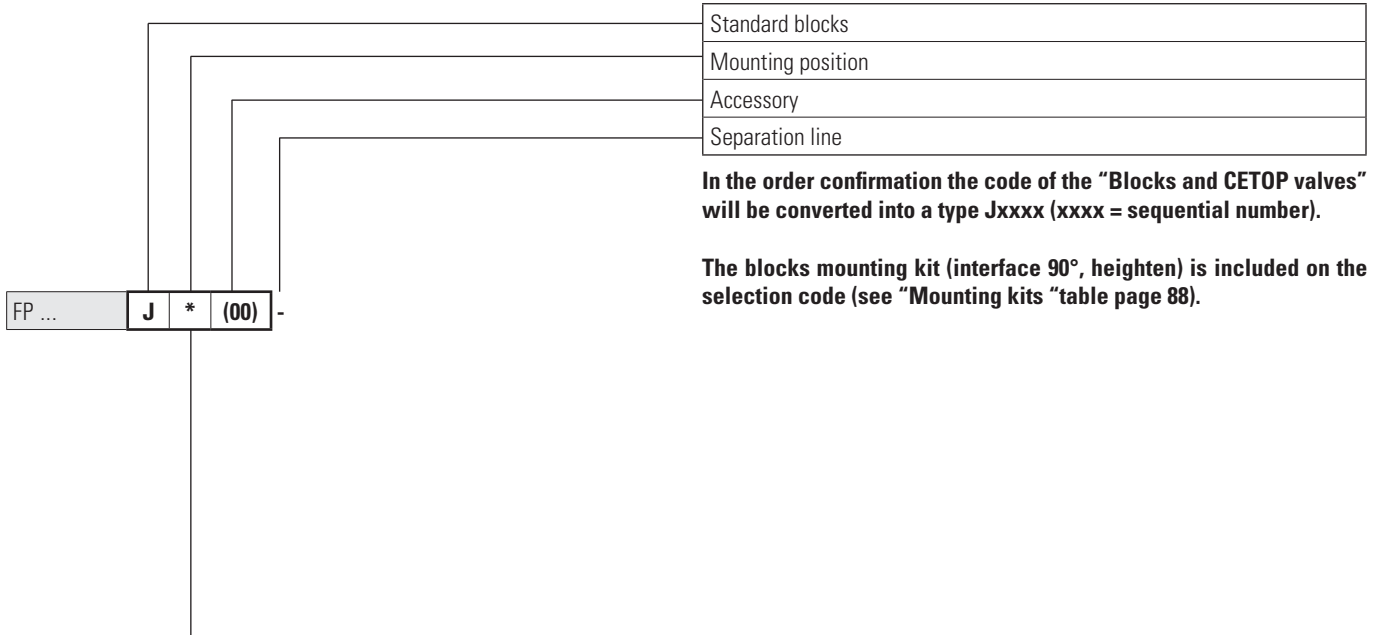

In the order confirmation the code of the "Blocks and CETOP valves" will be converted into a type Jxxxx (xxxx = sequential number).

The blocks mounting kit (interface 90°, heighten) is included on the selection code (see "Mounting kits" table page 88).

Blocks mounting on horizontal power pack

| | | | |
|--|--|--|--|
| <p>J 0</p> <p>Blocks orthogonal to the axis Except AC motors ref. size M-N-P</p> | <p>J A</p> <p>(V60403004)</p> <p>Blocks orthogonal to the axis with heighten For AC motors ref. size M-N-P</p> | <p>J B</p> <p>(V60403005)</p> <p>Blocks parallel to the axis with interface 90° Except AC motors ref. size P</p> | <p>J C</p> <p>(V60403005) (V60403004)</p> <p>Blocks parallel to the axis with heighten and interface 90° For AC motors ref. size P</p> |
|--|--|--|--|

The blocks can not be mounted with motors oriented in position "1" (DC motors, see page 76. AC motors, see page 82).

Blocks mounting on vertical power pack

| | | | |
|--|--|--|--|
| <p>J 0</p> <p>Blocks orthogonal to the axis Except AC motors ref. size M-N-P</p> | <p>J A</p> <p>(V60403004)</p> <p>Blocks orthogonal to the axis with heighten For AC motors ref. size M-N-P</p> | <p>J B</p> <p>(V60403005)</p> <p>Blocks parallel to the axis with interface 90° Except AC motors ref. size P</p> | <p>J C</p> <p>(V60403005) (V60403004)</p> <p>Blocks parallel to the axis with heighten and interface 90° For AC motors ref. size P</p> |
|--|--|--|--|

The blocks can not be mounted with motors oriented in position "1" - DC motors, see page 76. AC motors, see page 82.

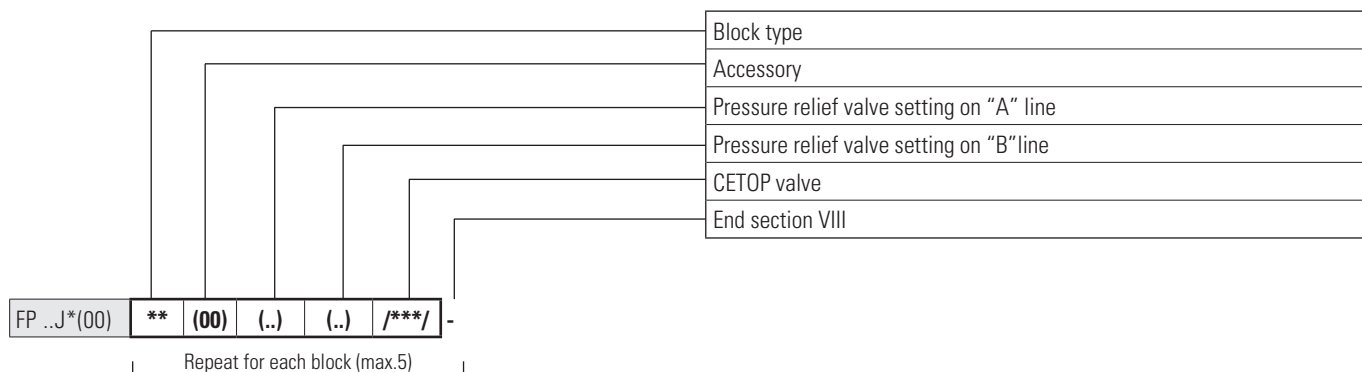

****** (00) (..) (..) /***/ - **Block type**

| ** | (00) | (..) | (..) | Description | Code | Drawing | Scheme |
|-----------|------|------|------|---|-----------|---------|--------|
| A2 | (00) | (0) | (0) | Middle parallel - Lateral ports G3/8" | V60403010 | | |
| A3 | (00) | (0) | (0) | Middle parallel - Rear ports G3/8" | V60403001 | | |
| B2 | (00) | (0) | (0) | Middle series - Lateral ports G3/8" | V60403011 | | |
| B3 | (00) | (0) | (0) | Middle series - Rear ports G3/8" | V60403003 | | |
| E1 | (00) | (0) | (0) | With pilot check valve on "A" port . Rear ports G1/4" | V60413002 | | |
| E2 | (00) | (0) | (0) | With pilot check valve on "B" port . Rear ports G1/4" | V60413003 | | |
| E3 | (00) | (0) | (0) | With pilot check valve on "A" and "B" ports . Rear ports G1/4" | V60413001 | | |

P1 - T1: thread, closing with plug G1/8" (Plug Q26622251 + Washer Q51435012)

Sect. VIII - Blocks and CETOP valves

****** (00) (..) (..) /***/ - **Block type**

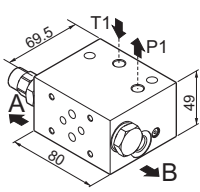
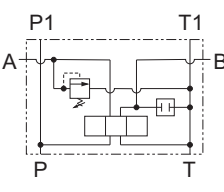
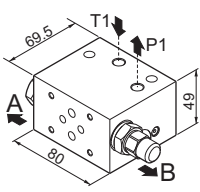
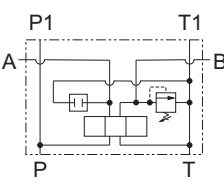
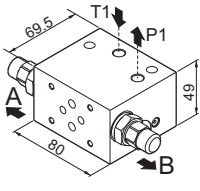
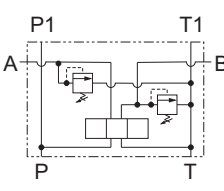
| ** | (00) | (..) | (..) | Description | Code | Drawing | Scheme |
|-----------|------|------------|------------|--|-----------|---|--|
| F1 | (00) | (A) | (0) | With pressure relief valve on "A" port Setting max. 70 bar - Rear ports G1/4" | V60413004 |  |  |
| | | (B) | (0) | With pressure relief valve on "A" port Setting max. 160 bar - Rear ports G1/4" | V60413007 | | |
| | | (C) | (0) | With pressure relief valve on "A" port Setting max. 330 bar - Rear ports G1/4" | V60413010 | | |
| F2 | (00) | (0) | (A) | With pressure relief valve on "B" port Setting max. 70 bar - Rear ports G1/4" | V60413005 |  |  |
| | | (0) | (B) | With pressure relief valve on "B" port Setting max. 160 bar - Rear ports G1/4" | V60413008 | | |
| | | (0) | (C) | With pressure relief valve on "B" port Setting max. 330 bar - Rear ports G1/4" | V60413011 | | |
| F3 | (00) | (A) | (A) | With pressure relief valve on "A" and "B" Setting max. 70 bar - Rear ports G1/4" | V60413006 |  |  |
| | | (B) | (B) | With pressure relief valve on "A" and "B" Setting max. 160 bar - Rear ports G1/4" | V60413009 | | |
| | | (C) | (C) | With pressure relief valve on "A" and "B" Setting max. 330 bar - Rear ports G1/4" | V60413012 | | |

P1 - T1: thread, closing with plug G1/8" (Plug Q26622251 + Washer Q51435012)

Mounting kits

| Mounting kit: blocks | For No. blocks | Code |
|---|----------------|-----------|
| Mounting position 0-2-3 | 1 | V60513007 |
| | 2 | V60513008 |
| | 3 | V60513009 |
| | 4 | V60513010 |
| Mounting position 1 (with heighten) | 1 | V60513011 |
| | 2 | V60513012 |
| | 3 | V60513013 |
| | 4 | V60513014 |

| Mounting kit: interface 90° | Code |
|-----------------------------|-----------|
| Mounting position 2 | V60513051 |

| Mounting kit: interface 90° with heighten | Code |
|---|-----------|
| Mounting position 3 | V60513049 |

The blocks mounting kit (interface 90°, heighten) is included on the selection code (see mounting position, page 85).

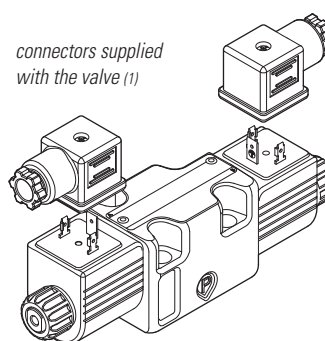

** (00) (..) (..) /***/ - **CETOP 3 valves**

| /***/ | Voltage | Code | Spool ⁽²⁾ | | | Screw kit for valve mounting |
|-------|---------------|--------------|----------------------|----------|--------|------------------------------|
| | | | Type | Mounting | Scheme | |
| /000/ | Without valve | | | | | |
| /001/ | 24 VDC (M) | ADC3E01CM001 | 01 | C | | V60513015 |
| /002/ | 12 VDC (L) | ADC3E01CL001 | | | | |
| /003/ | 24 VDC (M) | ADC3E02CM001 | 02 | C | | |
| /004/ | 12 VDC (L) | ADC3E02CL001 | | | | |
| /005/ | 24 VDC (M) | ADC3E03CM001 | 03 | C | | |
| /006/ | 12 VDC (L) | ADC3E03CL001 | | | | |
| /007/ | 24 VDC (M) | ADC3E04CM001 | 04 | C | | |
| /008/ | 12 VDC (L) | ADC3E04CL001 | | | | |

1 = Valves supplied with connector. Without connector see accessories page 89

2 = More details, features and performances, see catalog "Valves and Electronics" code DOC00078

Sect. IX - Accessories

| |
|------------------------|
| Accessories (optional) |
| First accessory |
| Second accessory |

FP **R** * *

| * | Description | Drawing | Code | Note |
|----------|--|---------|--|---|
| A | Standard foot, (galvanized sheet steel) thickness 2.5 mm (unassembled) | | Kit (foot and screws): 17010075 | All motors are compatible except orientation / 3 Tanks compatible (except for orientation / 3) S**A S**B S**C S**G S**L |
| B | Non-removable red plastic plug for pressure relief valve (unassembled) | | Plug: 60309200 | |
| C | Protection device for DC motors (supplied assembled) | | Kit (protectin, nut, tierods, washers): 17010048 | For motors: M2EN M4ES With blocks, please add the block code V60403004 |
| D | High foot, (galvanized sheet steel) thickness 2 mm (unassembled) | | Kit (foot and screws): 17010053 | All motors are compatible except orientation / 3 Tanks compatible (except for orientation / 3) S**A S**B S**C S**D S**F S**G S**L |
| E | Collar in welded sheet steel, thickness 2 mm (unassembled) | | Collar: 25000300 Tank fixing kit (screws and O-Ring): 17010080 | |
| F | Without valves connectors | | | |

Examples with FPA endhead

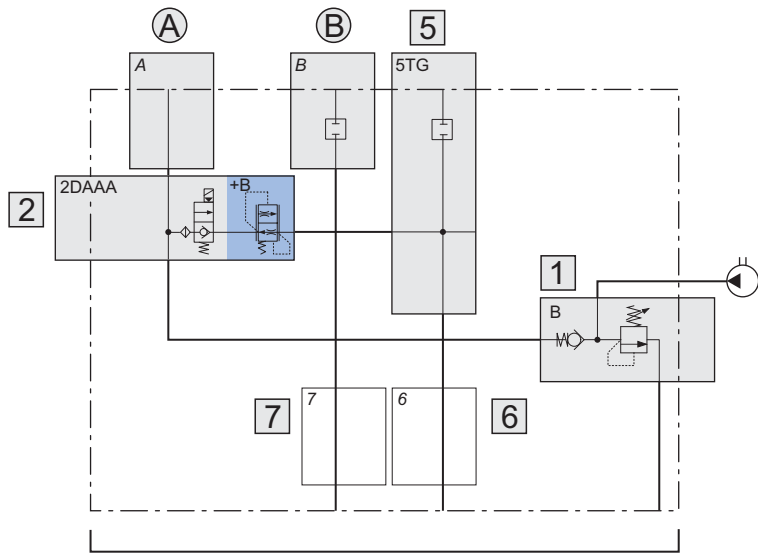

FPA 0 B1 2DAAA+B 5TG -03 - ..

| Cavity | Code | Description | Page |
|--------|----------|--|------|
| - | 0 | Thread ports P-T G1/4" (blocks interface) | 13 |
| 1 | B1 | Pressure relief valve with check valve (65 ÷ 180 bar) with screw and detachable closing, standard setting 150 bar | 14 |
| 2 | 2DAAA +B | Piloted solenoid valve normally closed, without emergency. Voltage 12 VDC + Flow control valve 1.4 l/min | 16 |
| 5 | 5TG | Plug | 18 |
| 6-7 | | Not specified, return lines 6 and 7 open | — |
| A-B | -03 | Combinations plugs on ports (A= open; B= with plug) | 20 |
| - | - | End section | — |

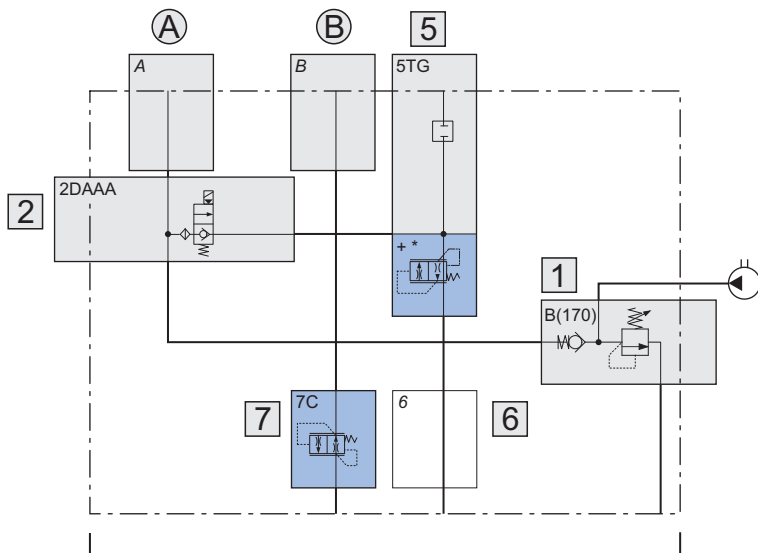

FPA 0 B1(90) 2DAAA 5TG+B 7C -01 - ..

| Cavity | Code | Description | Page |
|--------|--------|---|------|
| - | 0 | Thread ports P-T G1/4" (blocks interface) | 13 |
| 1 | B1(90) | Pressure relief valve with check valve with screw and detachable closing, special setting 90 bar | 14 |
| 2 | 2DAAA | Piloted solenoid valve normally closed, without emergency. Voltage 12 VDC | 16 |
| 5 | 5TG +B | Plug + Flow control valve 1.4 l/min | 18 |
| 6 | | Not specified, return line 6 open | — |
| 7 | 7C | Flow control valve on return 7, flow 2.1 l/min | 19 |
| A-B | -00 | Combinations plugs on ports (A,B= open) | 20 |
| - | - | End section | — |

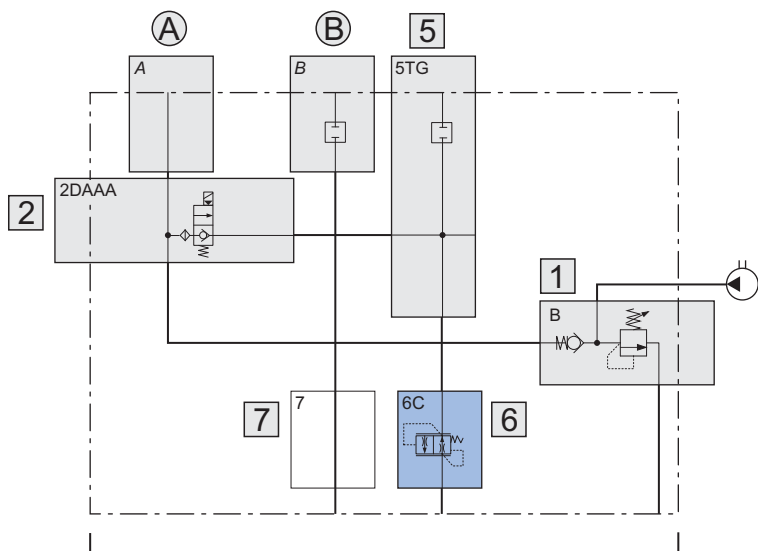

FPA 0 B1 2DAAA 5TG 6C -03 - ..

| Cavity | Code | Description | Page |
|--------|-------|--|------|
| - | 0 | Thread ports P-T G1/4" (blocks interface) | 13 |
| 1 | B1 | Pressure relief valve with check valve (65 ÷ 180 bar) with screw and detachable closing, standard setting 150 bar | 14 |
| 2 | 2DAAA | Piloted solenoid valve normally closed, without emergency. Voltage 12 VDC | 16 |
| 5 | 5TG | Plug | 18 |
| 6 | 6C | Flow control valve on return 6, flow 2.1 l/min | 19 |
| 7 | | Not specified, return line 7 open | — |
| A-B | -03 | Combinations plugs on ports (A= open ; B= with plug) | 20 |
| - | - | End section | — |

Examples with FPC endhead

FPC 0 B1 2DAAA 3TE 4TK 5TG+B 7C 9C -01 - ..

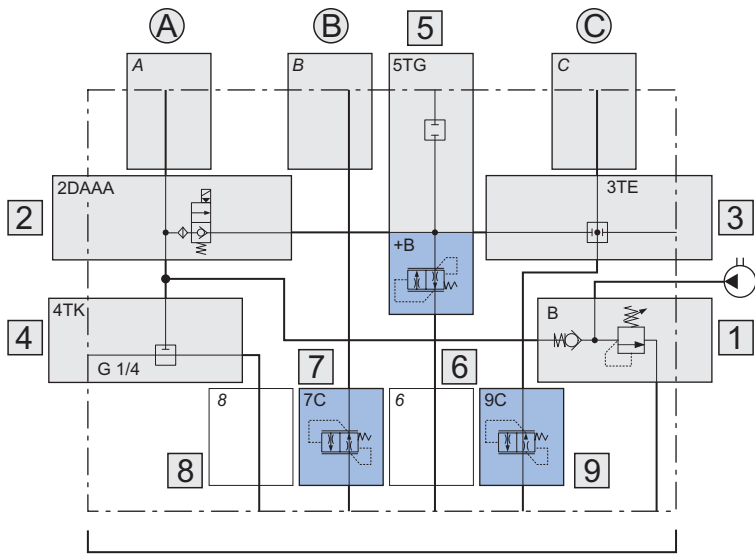

| Cavity | Code | Description | Page |
|--------|---------------|--|------|
| - | 0 | Thread ports P-T G1/4" (blocks interface) | 13 |
| 1 | B1 | Pressure relief valve with check valve (65 ÷ 180 bar) with screw and detachable closing, standard setting 150 bar | 21 |
| 2 | 2DAAA | Piloted solenoid valve normally closed, without emergency. Voltage 12 VDC | 23 |
| 3 | 3TE | Plug | 27 |
| 4 | 4TK | Plug (union G1/4) | 30 |
| 5 | 5TG +B | Plug + Flow control valve 1.4 l/min | 31 |
| 6 | | Not specified, return line 6 open | — |
| 7 | 7C | Flow control valve 2.1 l/min | 32 |
| 8 | | Not specified, return line 8 open | — |
| 9 | 9C | Flow control valve 2.1 l/min | 32 |
| A-B-C | -01 | Combinations plugs on ports (A-B-C= open) | 33 |
| - | - | End section | — |

FPC 0 B1(90) 2DAAA 3TC+B 4HA 5TH 8C -05 - ..

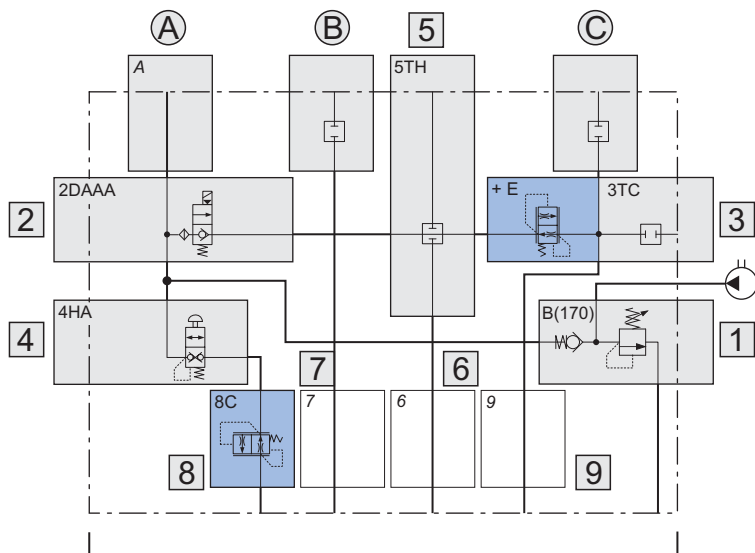

| Cavity | Code | Description | Page |
|--------|---------------|---|------|
| - | 0 | Thread ports P-T G1/4" (blocks interface) | 13 |
| 1 | B1(90) | Pressure relief valve with check valve with screw and detachable closing, special setting 90 bar | 21 |
| 2 | 2DAAA | Piloted solenoid valve normally closed, without emergency. Voltage 12 VDC | 23 |
| 3 | 3TG +B | Plug + Flow control valve 1.4 l/min | 27 |
| 4 | 4HA | Push-button control | 30 |
| 5 | 5TH | Plug | 31 |
| 6-7 | | Not specified, return lines 6 and 7 open | — |
| 8 | 8C | Flow control valve 2.1 l/min | 32 |
| 9 | | Not specified, return 9 open | — |
| A-B-C | -05 | Combinations plugs on ports (A = open; B-C= with plug) | 33 |
| - | - | End section | — |

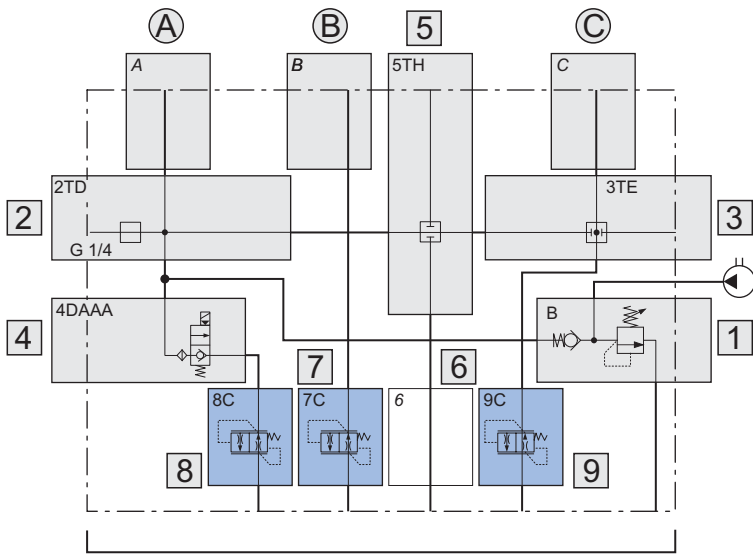

FPC 0 B1 2TD 3TE 4DAAA 5TH 7C 8C 9C -01 - ..

| Cavity | Code | Description | Page |
|--------|-------|--|------|
| - | 0 | Thread ports P-T G1/4" (blocks interface) | 13 |
| 1 | B1 | Pressure relief valve with check valve (65 ÷ 180 bar) with screw and detachable closing, standard setting 150 bar | 21 |
| 2 | 2TD | Plug (union G1/4) | 24 |
| 3 | 3TE | Plug | 26 |
| 4 | 4DAAA | Piloted solenoid valve normally closed, without emergency. Voltage 12 VDC | 29 |
| 5 | 5TH | Plug | 31 |
| 6 | | Not specified, return line 6 open | — |
| 7 | 7C | Flow control valve 2.1 l/min | 32 |
| 8 | 8C | Flow control valve 2.1 l/min | 32 |
| 9 | 9C | Flow control valve 2.1 l/min | 32 |
| A-B-C | -01 | Combinations plugs on ports (A-B-C= open) | 33 |
| - | - | End section | — |

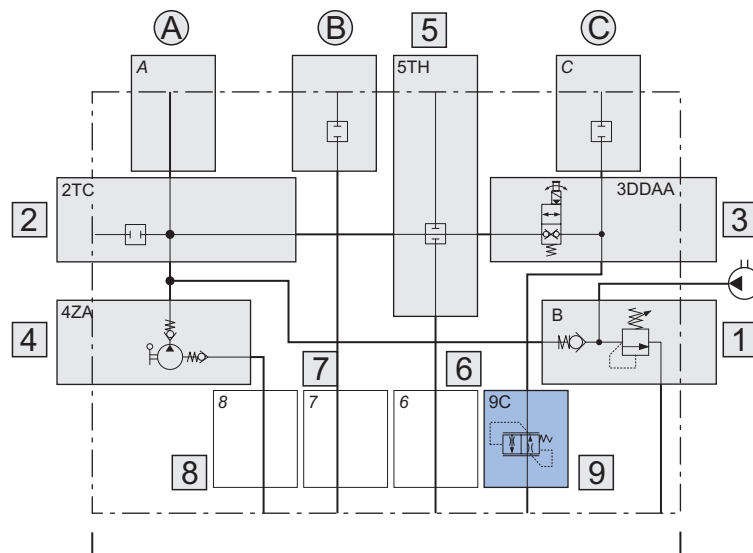

FPC 0 B1 2TC 3DDAA 4ZA 5TH 9C -06 - ..

| Cavity | Code | Description | Page |
|--------|-------|--|------|
| - | 0 | Thread ports P-T G1/4" (blocks interface) | 13 |
| 1 | B1 | Pressure relief valve with check valve (65 ÷ 180 bar) with screw and detachable closing, standard setting 150 bar | 21 |
| 2 | 2TC | Plug | 24 |
| 3 | 3DDAA | Piloted solenoid valve normally closed, with emergency. Voltage 12 VDC | 26 |
| 4 | 4ZA | Hand pump displacement 1cc | 30 |
| 5 | 5TH | Plug | 31 |
| 6-7-8 | | Not specified, return lines 6 - 7 - 8 open | — |
| 9 | 9C | Flow control valve 2.1 l/min | 32 |
| A-B-C | -05 | Combinations plugs on ports (A = open; B-C= with plug) | 33 |
| - | - | End section | — |

Examples with FPL endhead

FPL 0 B1 2DAAA 3DDAA 4DAAA 8C -04 - ..

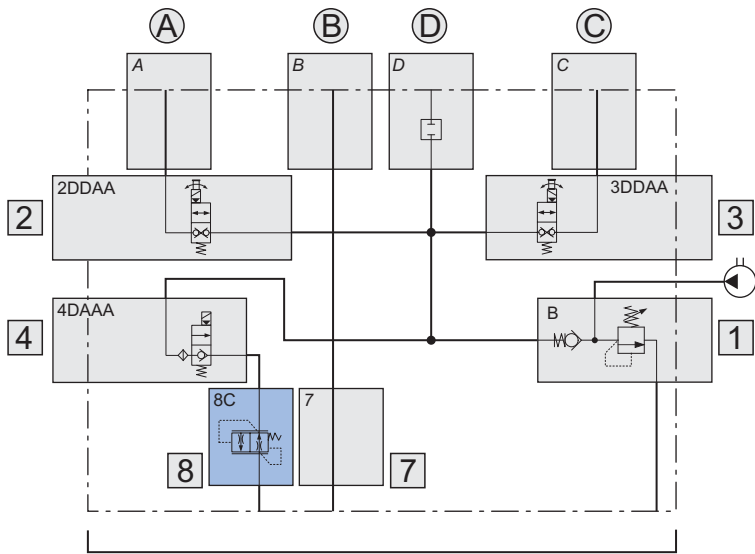

| Cavity | Code | Description | Page |
|---------|--------------|--|------|
| - | 0 | Thread ports P-T G1/4" (blocks interface) | 13 |
| 1 | B1 | Pressure relief valve with check valve (65 ÷ 180 bar) with screw and detachable closing, standard setting 150 bar | 34 |
| 2 | 2DDAA | Direct operated solenoid valve normally closed, with emergency Voltage 12 VDC | 36 |
| 3 | 3DDAA | Direct operated solenoid valve normally closed, with emergency Voltage 12 VDC | 39 |
| 4 | 4DAAA | Piloted solenoid valve normally closed, without emergency. Voltage 12 VDC | 42 |
| 7 | | Not specified, return line 7 open | — |
| 8 | 8C | Flow control valve 2.1 l/min | 44 |
| A-B-C-D | -04 | Combinations plugs on ports (A-B-C= open; D= with plug) | 45 |
| - | - | End section | — |

FPL 0 B1(100) 2DAAA 3DDAA 4TE -00 - ..

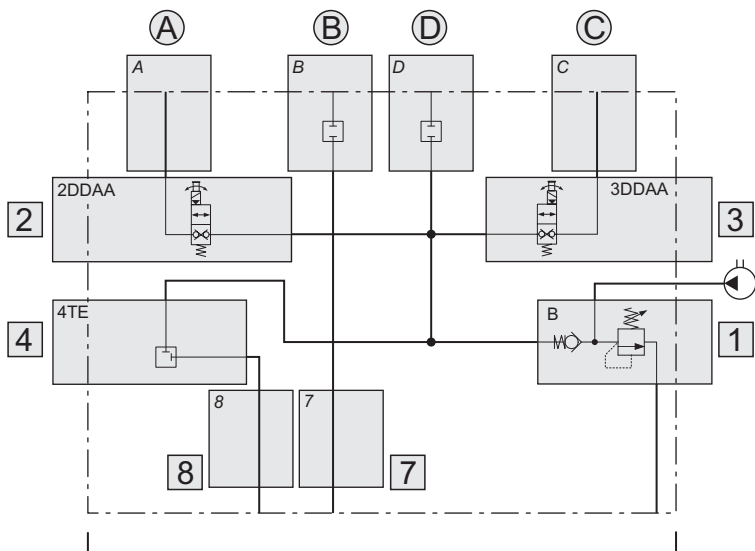

| Cavity | Code | Description | Page |
|---------|----------------|--|------|
| - | 0 | Thread ports P-T G1/4" (blocks interface) | 13 |
| 1 | B1(100) | Pressure relief valve with check valve with screw and detachable closing, special setting 100 bar | 34 |
| 2 | 2DDAA | Direct operated solenoid valve normally closed, with emergency Voltage 12 VDC | 36 |
| 3 | 3DDAA | Direct operated solenoid valve normally closed, with emergency Voltage 12 VDC | 39 |
| 4 | 4TE | Plug | 43 |
| 7-8 | | Not specified, return lines 7-8 open | — |
| A-B-C-D | -00 | Combinations plugs on ports (A-C = open; B-D= with plug) | 45 |
| - | - | End section | — |

Examples with FPE endhead

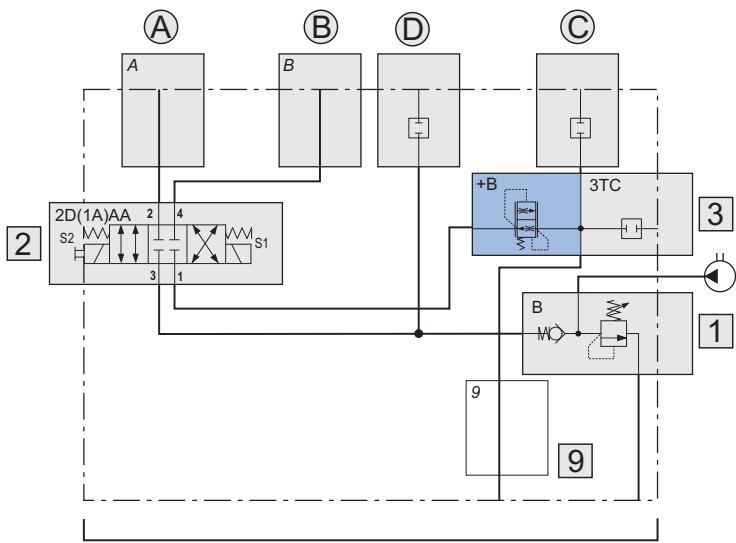

FPE 0 B1 2D(1A)AA 3TC+B -04 - ..

| Cavity | Code | Description | Page |
|------------|-----------------|--|------|
| - | 0 | Thread ports P-T G1/4" (blocks interface) | 13 |
| 1 | B1 | Pressure relief valve with check valve (65 ÷ 180 bar) with screw and detachable closing, standard setting 150 bar | 46 |
| 2 | 2D(1A)AA | Directional control valve 4 way 3 positions with emergency. Voltage 12 Vdc (closed centre "C" spool) | 48 |
| 3 | 3TC+B | Plug + Flow control valve 1.4 l/min | 50 |
| 9 | — | Not specified, return 9 open | — |
| A-B C-D | -04 | Combinations plugs on ports (A-B= with protection; C-D= with plug) | 52 |
| - | - | End section | — |

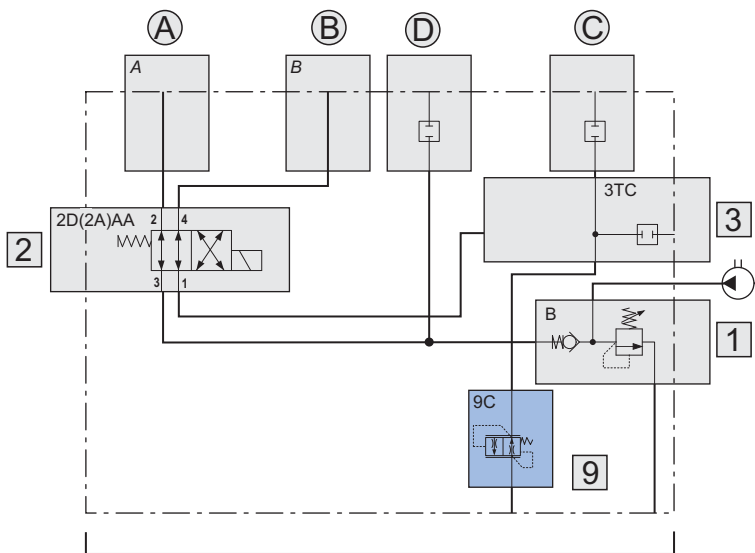

FPE B1 2D(2A)AA 3TC+B -04 - ..

| Cavity | Code | Description | Page |
|------------|-----------------|--|------|
| - | 0 | Thread ports P-T G1/4" (blocks interface) | 13 |
| 1 | B1 | Pressure relief valve with check valve (65 ÷ 180 bar) with screw and detachable closing, standard setting 150 bar | 46 |
| 2 | 2D(2A)AA | Directional control valve 4 way 2 positions without emergency. Voltage 12 Vdc (closed centre "C" spool) | 48 |
| 3 | 3TC | Plug | 50 |
| 9 | 9C | Flow control valve 2.1 l/min | 51 |
| A-B C-D | -04 | Combinations plugs on ports (A-B= with protection; C-D= with plug) | 52 |
| - | - | End section | — |



BREVINI®

Motion Systems

Code DOC00038 - Rev.08

Dana Brevini S.p.A.

Via Luciano Brevini 1/a

42124 Reggio Emilia

Tel. +39 0522 270711

Fax +39 0522 270660

www.dana.com/brevini

info@brevinifluidpower.com

