



**BREVINI<sup>®</sup>**

*Motion Systems*

## VALVES AND ELECTRONICS

**Technical Catalogue**

January  
**2018**

*web edition*

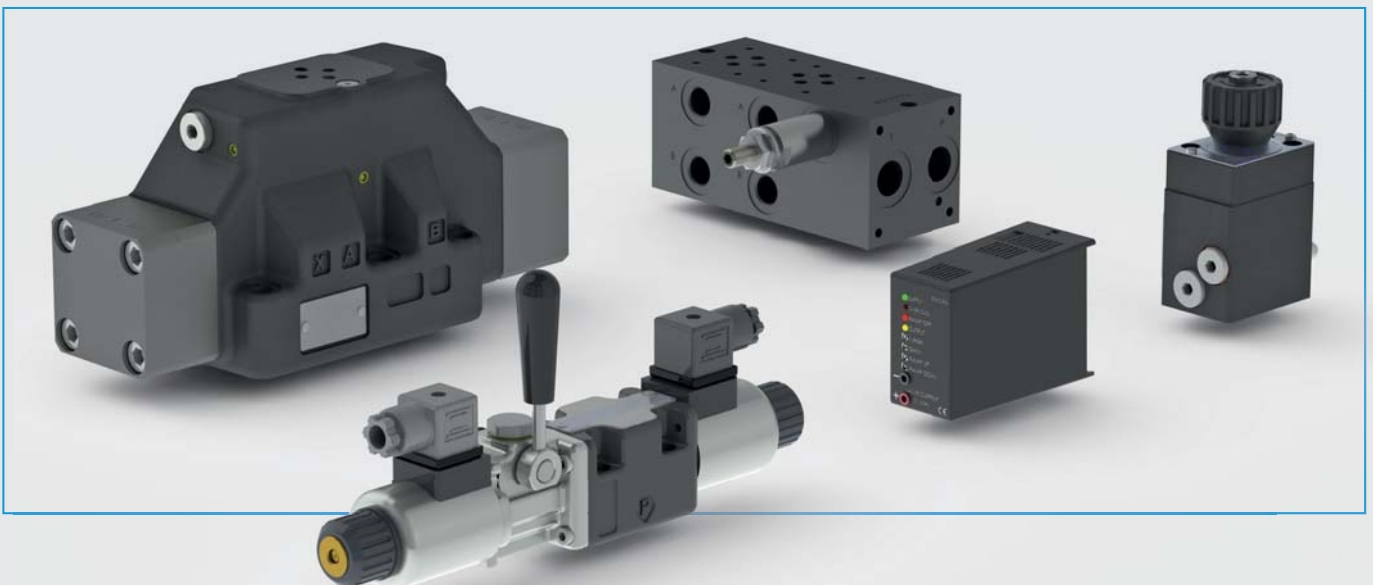



**BREVINI®**

Motion Systems

**VALVES AND ELECTRONICS  
TECHNICAL CATALOGUE 2018**

<b>CAP. I</b>	<b>DIRECTIONAL CONTROL</b>	<b>1</b>
<b>CAP. II</b>	<b>PRESSURE CONTROL</b>	<b>2</b>
<b>CAP. III</b>	<b>FLOW CONTROL</b>	<b>3</b>
<b>CAP. IV</b>	<b>MODULAR VALVES</b>	<b>4</b>
<b>CAP. V</b>	<b>CARTRIDGE VALVES ISO 7368</b> (SEE ALSO CATALOGUE CODE DOC00044)	<b>5</b>
<b>CAP. VI</b>	<b>IN LINE VALVES</b> (SEE CATALOGUE CODE DOC00044)	<b>6</b>
<b>CAP. VII</b>	<b>SUBPLATES</b>	<b>7</b>
<b>CAP. VIII</b>	<b>PROPORTIONAL CONTROL</b>	<b>8</b>
<b>CAP. IX</b>	<b>ELECTRONICS</b>	<b>9</b>
<b>CAP. X</b>	<b>SYSTEMS</b>	<b>10</b>
<b>CAP. XI</b>	<b>STACKABLE VALVES</b> (SEE CATALOGUE CODE DOC00046)	<b>11</b>
<b>CAP. XII</b>	<b>DC / AC STANDARD COILS</b> <b>"UL RECOGNIZED" COILS</b>	<b>12</b>

© 2018 Dana Brevini S.p.A. All rights reserved. Hydr-App, SAM Hydraulik, Aron, Brevini Hydraulics, BPE Electronics, VPS Brevini, OT Oiltechnology, logos are trademarks or are registered trademarks of Dana Brevini S.p.A. or other companies of the Dana Group in Italy and other countries.

The technical features supplied in this catalogue are non binding and no legal action can be taken against such material. Dana Brevini will not be held responsible for information and specifications which may lead to error or incorrect interpretations. Given the continuous technical research aimed at improved technical features of our products, Dana Brevini reserves the right to make change that are considered appropriate without any prior notice. This catalogue cannot be reproduced (in whole or in part) without the prior written consent of Dana Brevini. This catalogue supersedes all previous ones.

Use of the products in this catalogue must comply with the operating limits given in the technical specifications. The type of application and operating conditions must be assessed as normal or in malfunction in order to avoid endangering the safety of people and/or items.

# INDEX

## A

**A66..** \_\_\_\_\_ CAP. IV • 19  
**A88..** \_\_\_\_\_ CAP. IV • 34  
**AD2E...** \_\_\_\_\_ CAP. I • 4  
**AD3D...** \_\_\_\_\_ CAP. I • 18  
**AD3E...** \_\_\_\_\_ CAP. I • 11  
**AD3E...J\*** \_\_\_\_\_ CAP. I • 12  
**AD3I...** \_\_\_\_\_ CAP. I • 46  
**AD3L...** \_\_\_\_\_ CAP. I • 15  
**AD3M...** \_\_\_\_\_ CAP. I • 18  
**AD3O...** \_\_\_\_\_ CAP. I • 17  
**AD3P...** \_\_\_\_\_ CAP. I • 17  
**AD3RI...** \_\_\_\_\_ CAP. I • 48  
**AD3V...** \_\_\_\_\_ CAP. I • 14  
**AD3XD...** \_\_\_\_\_ CAP. I • 25  
**AD3XG...** \_\_\_\_\_ CAP. I • 29  
**AD5D...** \_\_\_\_\_ CAP. I • 38  
**AD5E...** \_\_\_\_\_ CAP. I • 36  
**AD5E...J\*** \_\_\_\_\_ CAP. I • 37  
**AD5E...Q5** \_\_\_\_\_ CAP. I • 37  
**AD5I...** \_\_\_\_\_ CAP. I • 47  
**AD5L...** \_\_\_\_\_ CAP. I • 39  
**AD5O...** \_\_\_\_\_ CAP. I • 38  
**AD5RI...** \_\_\_\_\_ CAP. I • 49  
**ADC3E...** \_\_\_\_\_ CAP. I • 5  
**ADH5...** \_\_\_\_\_ CAP. I • 53  
**ADH7...** \_\_\_\_\_ CAP. I • 57  
**ADH8...** \_\_\_\_\_ CAP. I • 62  
**ADL066...** \_\_\_\_\_ CAP. I • 69  
**ADL106** \_\_\_\_\_ CAP. I • 72

**ADP5E...** \_\_\_\_\_ CAP. I • 41  
**ADP5V...** \_\_\_\_\_ CAP. I • 44  
**ADPH5...** \_\_\_\_\_ CAP. I • 50  
**AM2QF...** \_\_\_\_\_ CAP. IV • 5  
**AM2UD...** \_\_\_\_\_ CAP. IV • 2  
**AM2UP...** \_\_\_\_\_ CAP. IV • 3  
**AM2VM...** \_\_\_\_\_ CAP. IV • 4  
**AM3ABU...** \_\_\_\_\_ CAP. III • 4  
**AM3CP...** \_\_\_\_\_ CAP. IV • 11  
**AM3H...** \_\_\_\_\_ CAP. VIII • 15  
**AM3QF...** \_\_\_\_\_ CAP. IV • 17  
**AM3RD...** \_\_\_\_\_ CAP. IV • 12  
**AM3RGT...** \_\_\_\_\_ CAP. IV • 20  
**AM3SD...** \_\_\_\_\_ CAP. IV • 12  
**AM3SH...** \_\_\_\_\_ CAP. IV • 16  
**AM3UD...** \_\_\_\_\_ CAP. IV • 7  
**AM3UP...** \_\_\_\_\_ CAP. IV • 8  
**AM3UP1...** \_\_\_\_\_ CAP. IV • 8  
**AM3VI...** \_\_\_\_\_ CAP. IV • 9  
**AM3VM...** \_\_\_\_\_ CAP. IV • 9  
**AM3VR...** \_\_\_\_\_ CAP. IV • 13  
**AM3VS...** \_\_\_\_\_ CAP. IV • 15  
**AM3XMP...** \_\_\_\_\_ CAP. VIII • 25  
**AM5CP...** \_\_\_\_\_ CAP. IV • 26  
**AM5H...** \_\_\_\_\_ CAP. VIII • 16  
**AM5QF...** \_\_\_\_\_ CAP. IV • 31  
**AM5RGT...** \_\_\_\_\_ CAP. IV • 35  
**AM5SH...** \_\_\_\_\_ CAP. IV • 30  
**AM5UD...** \_\_\_\_\_ CAP. IV • 22  
**AM5UP...** \_\_\_\_\_ CAP. IV • 23

**AM5VI...** \_\_\_\_\_ CAP. IV • 24  
**AM5VM...** \_\_\_\_\_ CAP. IV • 24  
**AM5VR...** \_\_\_\_\_ CAP. IV • 27  
**AM5VS...** \_\_\_\_\_ CAP. IV • 29  
**AM7QF...** \_\_\_\_\_ CAP. IV • 38  
**AM7UP...** \_\_\_\_\_ CAP. IV • 37  
**AM66...** \_\_\_\_\_ CAP. IV • 18  
**AM88...** \_\_\_\_\_ CAP. IV • 33

## B

**BA60.. / BA10...** \_\_\_\_\_ CAP. X • 2  
**BA130.. / BA10...** \_\_\_\_\_ CAP. X • 5  
**BC0625/27...** \_\_\_\_\_ CAP. VII • 14  
**BC0630/32...** \_\_\_\_\_ CAP. VII • 15  
**BC0640...** \_\_\_\_\_ CAP. VII • 15  
**BC0641/\*...** \_\_\_\_\_ CAP. VII • 15  
**BC06XPQ3...** \_\_\_\_\_ CAP. VII • 13  
**BC06XQ3...** \_\_\_\_\_ CAP. VII • 13  
**BC1006...** \_\_\_\_\_ CAP. VII • 27  
**BC250AB...** \_\_\_\_\_ CAP. VII • 4  
**BC250PT...** \_\_\_\_\_ CAP. VII • 4  
**BC251...** \_\_\_\_\_ CAP. VII • 4  
**BC307...** \_\_\_\_\_ CAP. VII • 12  
**BC308...** \_\_\_\_\_ CAP. VII • 13  
**BC309...** \_\_\_\_\_ CAP. VII • 13  
**BC3107...** \_\_\_\_\_ CAP. VII • 12  
**BC325/27...** \_\_\_\_\_ CAP. VII • 10  
**BC330/32...** \_\_\_\_\_ CAP. VII • 10  
**BC340...** \_\_\_\_\_ CAP. VII • 10  
**BC341/\*...** \_\_\_\_\_ CAP. VII • 11

# INDEX

<b>BC350...</b> CAP. VII • 12	<b>BS216...</b> CAP. VII • 3	<b>BSH531...</b> CAP. I • 56
<b>BC351...</b> CAP. VII • 12	<b>BS220...</b> CAP. VII • 3	<b>BSH712...</b> CAP. I • 60
<b>BC507...</b> CAP. VII • 27	<b>BS3.**...</b> CAP. VII • 7	<b>BSH713...</b> CAP. I • 60
<b>BC5107...</b> CAP. VII • 27	<b>BS310/11...</b> CAP. VII • 8	<b>BSH714...</b> CAP. I • 60
<b>BC530/32...</b> CAP. VII • 26	<b>BS312/13...</b> CAP. VII • 8	<b>BSH715...</b> CAP. I • 61
<b>BC536/28...</b> CAP. VII • 24	<b>BS314/15...</b> CAP. VII • 8	<b>BSH716...</b> CAP. I • 61
<b>BC53A...</b> CAP. VII • 27	<b>BS316/17...</b> CAP. VII • 8	<b>BSH717...</b> CAP. I • 61
<b>BC540...</b> CAP. VII • 25	<b>BS32...</b> CAP. VII • 3	<b>BSH813*...</b> CAP. I • 65
<b>BC541/*...</b> CAP. VII • 25	<b>BS320/21...</b> CAP. VII • 9	<b>BSH813...</b> CAP. I • 65
<b>BC550...</b> CAP. VII • 26	<b>BS3W...</b> CAP. VII • 9	<b>BSH815...</b> CAP. I • 65
<b>BC551...</b> CAP. VII • 26	<b>BS5.**...</b> CAP. VII • 19	<b>BSH817...</b> CAP. I • 65
<b>BDL066...</b> CAP. I • 70	<b>BS512...</b> CAP. VII • 20	
<b>BM2...</b> CAP. VII • 5	<b>BS513...</b> CAP. VII • 20	<b>C</b>
<b>BM250...</b> CAP. VII • 6	<b>BS514...</b> CAP. VII • 20	<b>C*P...</b> CAP. V • 10
<b>BM260...</b> CAP. VII • 5	<b>BS515...</b> CAP. VII • 20	<b>CDL046...</b> CAP. I • 66
<b>BM270...</b> CAP. VII • 6	<b>BS516...</b> CAP. VII • 21	<b>CDL066...</b> CAP. I • 68
<b>BM3...</b> CAP. VII • 16	<b>BS517...</b> CAP. VII • 21	<b>CDL106</b> CAP. I • 71
<b>BM350...</b> CAP. VII • 17	<b>BS529...</b> CAP. VII • 23	<b>CEPS...</b> CAP. IX • 2
<b>BM352...</b> CAP. VII • 18	<b>BS53...</b> CAP. VII • 21	<b>CMP10...</b> CAP. VII • 30
<b>BM360...</b> CAP. VII • 16	<b>BS530/31...</b> CAP. VII • 22	<b>CMP16/25./CMPE16/25..</b> CAP. V • 12
<b>BM370...</b> CAP. VII • 17	<b>BS5RGA...</b> CAP. X • 8	<b>CONNECTORS STANDARD</b> CAP. I • 20
<b>BM372...</b> CAP. VII • 18	<b>BS5RIA...</b> CAP. X • 8	<b>CSP16/25...</b> CAP. V • 12
<b>BM5...</b> CAP. VII • 28	<b>BSVMP10...</b> CAP. VII • 9	<b>CUP16/25./CUPE16/25..</b> CAP. V • 12
<b>BM550...</b> CAP. VII • 28	<b>BSVMP16...</b> CAP. II • 11	
<b>BM560...</b> CAP. VII • 29	<b>BSVMP20...</b> CAP. VII • 23	<b>J</b>
<b>BM570...</b> CAP. VII • 29	<b>BSVMP25...</b> CAP. II • 11	<b>JC3D...</b> CAP. IX • 26
<b>BM580...</b> CAP. VII • 29	<b>BSVMP25/1...</b> CAP. II • 11	<b>JC5D...</b> CAP. IX • 28
<b>BS2.**...</b> CAP. VII • 2	<b>BSC569...</b> CAP. X • 7	<b>JCFD...</b> CAP. IX • 30
<b>BS212...</b> CAP. VII • 2	<b>BSH513...</b> CAP. I • 56	
<b>BS214...</b> CAP. VII • 2	<b>BSH517...</b> CAP. I • 56	

# INDEX

## K

KEC... \_\_\_\_\_ CAP. V • 5  
KEC\*\*M\*/U\*/SL... \_\_\_\_\_ CAP. V • 10  
KEC16CQ... \_\_\_\_\_ CAP. V • 7  
KEC16ME../KEC16MP.. \_\_\_\_\_ CAP. V • 11  
KEC16PC... \_\_\_\_\_ CAP. V • 8  
KEC16RC... \_\_\_\_\_ CAP. V • 8  
KEC16RI... \_\_\_\_\_ CAP. V • 7  
KEC16SH../KEC16SP.. \_\_\_\_\_ CAP. V • 9  
KEC16SL... \_\_\_\_\_ CAP. V • 11  
KEC16UE../KEC16UN.. \_\_\_\_\_ CAP. V • 11  
KEC25CQ... \_\_\_\_\_ CAP. V • 7  
KEC25ME... \_\_\_\_\_ CAP. V • 11  
KEC25MP... \_\_\_\_\_ CAP. V • 11  
KEC25PC... \_\_\_\_\_ CAP. V • 8  
KEC25RC... \_\_\_\_\_ CAP. V • 8  
KEC25RI... \_\_\_\_\_ CAP. V • 7  
KEC25SH... \_\_\_\_\_ CAP. V • 9  
KEC25SL... \_\_\_\_\_ CAP. V • 11  
KEC25SP... \_\_\_\_\_ CAP. V • 9  
KEC25UE../KEC25UN.. \_\_\_\_\_ CAP. V • 11  
KEL... \_\_\_\_\_ CAP. V • 3  
KEL16/25... \_\_\_\_\_ CAP. V • 4  
KRA16/25... \_\_\_\_\_ CAP. V • 13

## L

LAB3 \_\_\_\_\_ CAP. IX • 13  
LVDT \_\_\_\_\_ CAP. I • 22  
LE VARIANT \_\_\_\_\_ CAP. I • 21

## M

MAV1152 \_\_\_\_\_ CAP. IX • 17  
MAV1152HY \_\_\_\_\_ CAP. IX • 20  
MAV4211 \_\_\_\_\_ CAP. IX • 23

## P

PVR3... \_\_\_\_\_ CAP. II • 2  
PVR5... \_\_\_\_\_ CAP. II • 4  
PVRU3... \_\_\_\_\_ CAP. II • 2  
PVRU5... \_\_\_\_\_ CAP. II • 4  
PVS3... \_\_\_\_\_ CAP. II • 2  
PVS5... \_\_\_\_\_ CAP. II • 4  
PVSU3... \_\_\_\_\_ CAP. II • 2  
PVSU5... \_\_\_\_\_ CAP. II • 4

## Q

QC32... \_\_\_\_\_ CAP. III • 2  
QC33... \_\_\_\_\_ CAP. III • 3  
QCV32 \_\_\_\_\_ CAP. III • 5

## R

REMDRA... \_\_\_\_\_ CAP. IX • 7  
REMSRA... \_\_\_\_\_ CAP. IX • 4

## S

SE3AN21RS... \_\_\_\_\_ CAP. IX • 11

### STUDS - MODULAR VALVES

CETOP 2 \_\_\_\_\_ CAP. IV • 6  
CETOP 3 \_\_\_\_\_ CAP. IV • 21  
CETOP 5 \_\_\_\_\_ CAP. IV • 36

## V

VML / VSL / VUL... \_\_\_\_\_ CAP. II • 6  
VMP / VSP / VUP... \_\_\_\_\_ CAP. II • 6

## X

XD2A... / XD2C... \_\_\_\_\_ CAP. VIII • 2  
XD3A... / XD3C... \_\_\_\_\_ CAP. VIII • 4  
XDC3. SERIE 2 \_\_\_\_\_ CAP. VIII • 10  
XDP3A../XDP3C.. \_\_\_\_\_ CAP. VIII • 6  
XDP5A../XDP5C... \_\_\_\_\_ CAP. VIII • 8  
XEPV3... \_\_\_\_\_ CAP. VIII • 12  
XP3... \_\_\_\_\_ CAP. VIII • 23  
XQ3... \_\_\_\_\_ CAP. VIII • 17  
XQP3... \_\_\_\_\_ CAP. VIII • 19  
XQP5... \_\_\_\_\_ CAP. VIII • 21

# TECHNICAL INFORMATION

## INTRODUCTION

Read this instructions carefully before installation. All operations must be carried out by qualified personnel following the instructions.

The user must periodically inspect, based on the conditions of use and the substances used, the presence of corrosion, dirt, the state of wear and correct function of the valves.

**Always observe first the operating conditions given in datasheet of the valve.**

## HYDRAULIC FLUID

Observe the recommendations given in the data sheet of the valve. Use only mineral oil (HL, HLP) according to DIN 51524. Use of other different fluids may damage the good operation of the valve.

## VISCOSITY

Observe the recommendations given in the data sheet of the valve. The oil viscosity must be in the range of 10 mm<sup>2</sup>/s to 500 mm<sup>2</sup>/s.

Recommended oil viscosity 46 mm<sup>2</sup>/s (32 mm<sup>2</sup>/s for Cartridge valves)

Table 1: ISO viscosity grades

Viscosity grade	Average kinematic viscosity mm <sup>2</sup> /s @ 40°C	Kinematic-viscosity limits mm <sup>2</sup> /s @ 40°C	
		min.	max.
ISO VG 10	10	9.00	11.0
ISO VG 15	15	13.5	16.5
ISO VG 22	22	19.8	24.2
ISO VG 32	32	28.8	35.2
ISO VG 46	46	41.4	50.6
ISO VG 68	68	61.2	74.8
ISO VG 100	100	90.0	110

■ = Values used in the chart "Oil viscosity according to temperature"

## CONVERSION TABLE SSU / °E / mm<sup>2</sup>/s

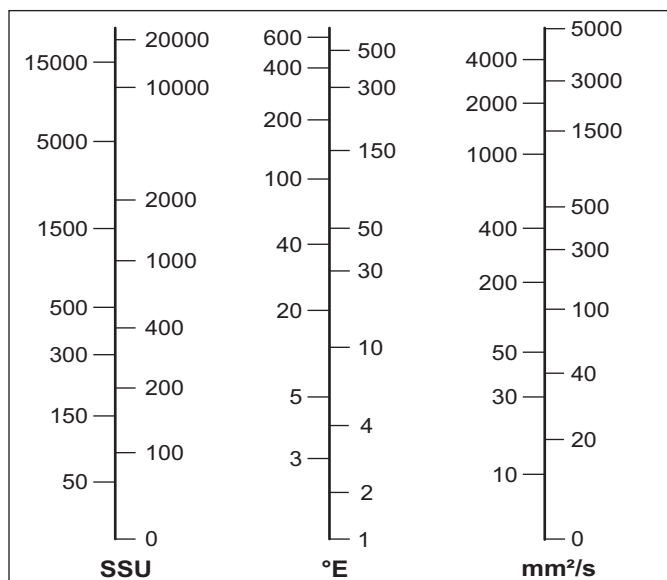

## OIL VISCOSITY ACCORDING TO TEMPERATURE

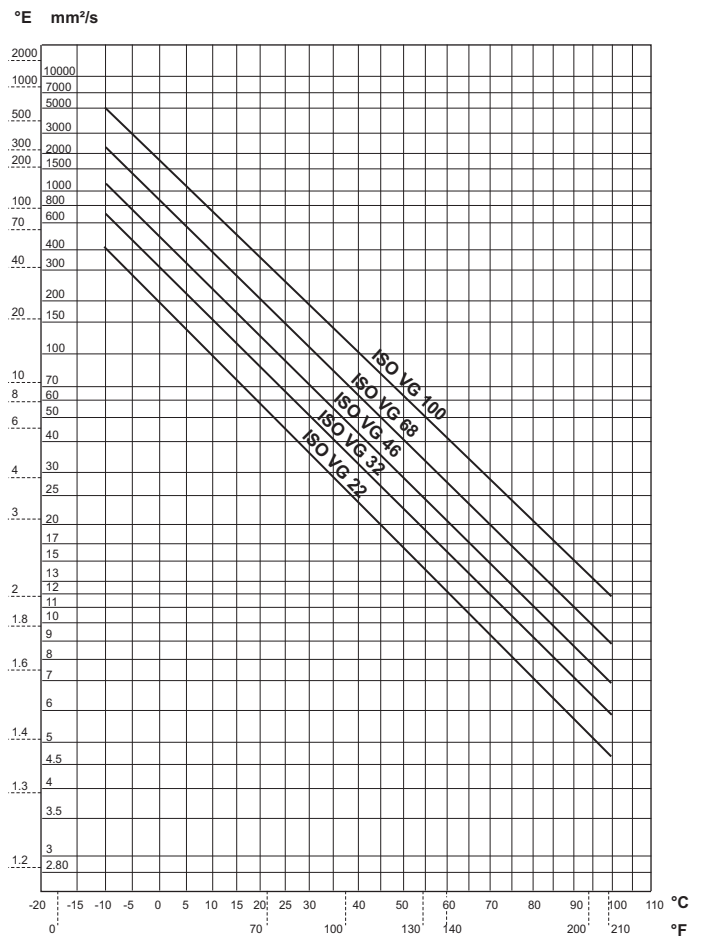

## CONTAMINATION

Oil contamination is the main cause of faults and malfunction in hydraulic systems. Abrasive particles in the fluid erode or block moving parts, leading to system malfunction.

The valves we are offering do not require filtering characteristics any higher than those needed for usual hydraulic components such as pumps, motors, etc.

However, accurate filtering does guarantee reliability and a long life to all the system's hydraulic parts. Reliable performance and long working life for all oil-pressure parts is assured by maintaining the level of fluid contamination within the limits specified in the data sheet of the valve.

Hydraulic fluid must also be cleaned properly before filling the hydraulic circuit, especially when commissioning a new system, as this is when the oil contamination generally peaks due to its flushing effect on the components, and the running-in of the pump.

Maximum contamination level is required on datasheet of the valve according to ISO 4406:1999.

In the following table there is the correspondence between ISO 4406:1999 and old standard NAS 1638 for information purpose:

The standard ISO 4406:1999 defines the contamination level with three numbers that relate with the number of particles of average dimension equal or greater than 4 µm, 6 µm e 14 µm, in 1 ml of fluid.

In following table there is a reference to recommended contamination level and correspondence with old NAS 1638 standard.

# TECHNICAL INFORMATION

Table 2: Recommended contamination level.

Type of system Type of valve	Oil filtration recommendations		
	Cleanliness class recommended		Absolute filtration micron rating (**)
	ISO 4406 : 1999	NAS 1638 (*)	
Systems or components operating at HIGH PRESSURE > 250 bar (3600 psi) HIGH DUTY CYCLE APPLICATIONS Systems or components with LOW dirt tolerance	18 / 16 / 13	7 - 8	5
Systems or components operating at MEDIUM / HIGH PRESSURE Systems and components with moderate dirt tolerance	19 / 17 / 14	9	10
Systems or components operating at LOW PRESSURE < 100 bar (1500 psi) LOW DUTY CYCLE APPLICATIONS Systems and components with GOOD dirt tolerance	20 / 18 / 15	10 - 11	20

\* Contamination class NAS 1638: it is determined by counting the total particles of different size ranges contained in 100 ml of fluid.

\*\* Absolute filtration: it is a characteristic of each filter, it refers the size (in micron) of the largest spherical particle which may pass through the filter.

## WORKING TEMPERATURES

Ambient temperature range: -25°C to +60°C

Fluid temperature range (NBR seals): -25°C to +75°C

Thermal shocks can affect the performance and the expected life of the product, hence it is necessary to protect the product from these conditions.

## SEALS

O-rings made in Acrylonitrile Butadiene (NBR) are normally fitted on the valves. The backup rings that protect the O-rings are also made in NBR, or sometimes PTFE. Both the O-rings and the backup rings are suitable for the working temperatures mentioned above.

In the case of fluid temperatures > 75°C, FKM seals must be used (identified with "V1" variant).

## ELECTRICAL POWER SUPPLY

Solenoid valves coils are designed to operate safely in the voltage range of ±10% of nominal voltage at max. 60°C ambient temperature. The combination of permanent overvoltage and very hot temperatures can stress the solenoid. Therefore always a good heat dissipation and voltage level has to be assured. Faulty coils may only be replaced by new, interchangeable, tested components in original-equipment quality.

Before removing a coil, voltage must be disconnected.

When replacing the coil, be aware to insert O-Rings in order to avoid the entrance of water.

## INSTALLATION

The mounting surface must feature surface quality specified in data sheet of the valve: for example for Cetop valves generally is required  $Ra \leq 1.6\mu m$  and flatness  $\leq 0.03 mm$  over 100 mm length. Normally in cartridge valve for sealing diameters of the cavities, is required roughness  $Ra \leq 1.6\mu m$ . The surfaces and openings in the assembly plate must be free from impurity or dirt.

Make sure the O-Rings fit correctly in their seats.

Fixing screws must comply with the dimensions and the strength class specified in the data sheet and must be tightened at the specified tightening torque.

Complete the electrical wiring. For circuit examples and pin assignments, see the relevant datasheet.

## USE AND MAINTENANCE

Observe the functional limits indicated in the technical catalogue

On a periodic basis and based on the conditions of use, check for cleanliness, state of wear or fractures and correct performance of the valve.

If the O-rings are damaged, replace them with those supplied by the manufacturer.

To assure the best working conditions at all time, check the oil and replace it periodically (after the first 100 working hours and then after every 2000 working hours or at least once every year).

Attention: all installation and maintenance intervention must be performed by qualified staff.

## TRANSPORT AND STORAGE

The valve must be handled with care to avoid damage caused by impact, which could compromise its efficiency.

In the case of storage, keep the valves in a dry place and protect against dust and corrosive substances.

When storing for periods of more than 6 months, fill the valve with preserving oils and seal it.

## WARRANTY AND SUPPLY CONDITIONS

For the general warranty and supply conditions, please consult the specific sales contract or the "General terms and conditions of sale" document IOP 7-2-05. Downloaded from the website: [www.brevinifluidpower.com](http://www.brevinifluidpower.com)

## CONVERSION CHART

Type	SI units		Alternative units		Conversion factor
Force	Newton	(N) [kgm/s <sup>2</sup> ]	Kilogram force	(kgf)	1 kgf = 9.807 N
			pound force	(lbf) [lbf/s <sup>2</sup> ]	1 lbf = 4.448 N
Length	millimeter	(mm) [10 m]	inch	(in)	1 in = 25.4 mm
	meter	(m) [1000 m]	yard	(yd) [3ft]	1 m = 1.0936 yd
	kilometer	(km) [1000 m]	mile	(mile) [1760 yd]	1 mile = 1.609 km
Torque	Newton meter	(Nm)	pound force.feet	(lbf.ft)	1 lbf.ft = 1.356 Nm
Power	kiloWatt (kW)	[1000 Nm/s]	horsepower	(hp)	1 kW = 1.341 hp
			metric horsepower	(CV)	1 kW = 1.36 CV
Pressure	MegaPascal	(MPa) [ N/mm <sup>2</sup> ]	bar		1 MPa = 10 bar
			psi (lbf/in <sup>2</sup> )		1 MPa = 145 psi
			ton/f/in <sup>2</sup>		1 ton/f/in <sup>2</sup> = 15.45 MPa
Flow rate	liter/min	(l/min)	UK gal/min		1 UK gal/min = 4.546 l/min
			US gal/min		1 US gal/min = 3.785 l/min
Temperature	Degrees Celsius	(°C)	Fahrenheit	(°F)	1°F = 1.8 °C+32



**ABBREVIATIONS**

<b>AP</b>	HIGH PRESSURE CONNECTION
<b>AS</b>	PHASE LAG (DEGREES)
<b>BP</b>	LOW PRESSURE CONNECTION
<b>C</b>	STROKE (MM)
<b>CH</b>	ACROSS FLATS
<b>Ch</b>	INTERNAL ACROSS FLATS
<b>DA</b>	AMPLITUDE DECAY (dB)
<b>DP</b>	DIFFERENTIAL PRESSURE (BAR)
<b>F</b>	FORCE (N)
<b>I%</b>	INPUT CURRENT (A)
<b>M</b>	MANOMETER CONNECTION
<b>NG</b>	KNOB TURNS
<b>OR</b>	SEAL RING
<b>P</b>	LOAD PRESSURE (BAR)
<b>PARBAK</b>	PARBAK RING
<b>PL</b>	PARALLEL CONNECTION
<b>Pr</b>	REDUCED PRESSURE (BAR)
<b>Q</b>	FLOW (L/MIN)
<b>QP</b>	PUMP FLOW (L/MIN)
<b>SE</b>	ELASTIC PIN
<b>SF</b>	BALL
<b>SR</b>	SERIES CONNECTION
<b>X</b>	PILOTING
<b>Y</b>	DRAINAGE

**DIRECTIONAL CONTROL VALVES**

**CETOP 2/NG04**

**CETOP 3/NG06**

**CETOP 3**

**ATEX 2014/34/UE  
directive**

**CETOP 5/NG10**

**CETOP 5/NG10  
High performances**

**Automatic reciprocating valves**

**Piloted valves  
and subplate mounting**

**Flow diversion valves**



**CETOP 2/NG04**



CETOP 2/NG04	CAP. I • 2
AD2E...	CAP. I • 4
"A09" DC COILS	CAP. I • 4

**ATEX 2014/34/UE DIRECTIVE**

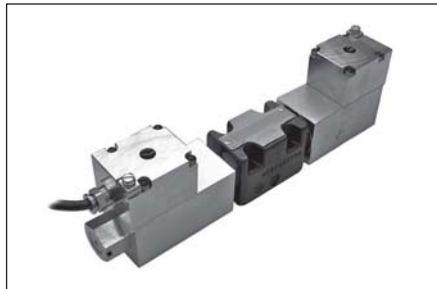

ATEX 2014/34/UE DIRECTIVE	CAP. I • 23
AD3XD...	CAP. I • 25
AD3XG...	CAP. I • 29

**AUTOMATIC RECIPROCATING VALVES**



AD3I...	CAP. I • 46
AD5I...	CAP. I • 47
AD3RI...	CAP. I • 48
AD5RI...	CAP. I • 49

**CETOP 3/NG06**



ADC3...	CAP. I • 5
"A09" DC COILS	CAP. I • 7

**CETOP 5/NG10**



CETOP 5/NG10	CAP. I • 33
AD5E...	CAP. I • 36
AD5E...J* AND AD5E...Q5	CAP. I • 37
AD5O... AND AD5D...	CAP. I • 38
AD5L...	CAP. I • 39
"A16" DC COILS	CAP. I • 40
"K16" AC SOLENOIDS	CAP. I • 41

**PILOTED VALVES AND SUBPLATE MOUNTING**



ADPH5...	CAP. I • 50
ADH5...	CAP. I • 53
BSH5...	CAP. I • 56
ADH7...	CAP. I • 57
BSH7...	CAP. I • 60
ADH8...	CAP. I • 62
BSH8...	CAP. I • 65

**CETOP 3**



CETOP 3/NG06	CAP. I • 8
AD3E...	CAP. I • 11
AD3E...J*	CAP. I • 12
AD3V...	CAP. I • 14
AD3L...	CAP. I • 15
CETOP 3 OTHER OPERATORS	CAP. I • 16
AD3P... AND AD3O...	CAP. I • 17
AD3M... AND AD3D...	CAP. I • 18
"D15" DC COILS	CAP. I • 19
"B14" AC SOLENOIDS	CAP. I • 19
STANDARD CONNECTORS	CAP. I • 20
"LE" VARIANTS FOR ADC3/AD3	CAP. I • 21
LVDT	CAP. I • 22

**CETOP 5/NG10 HIGH PERFORMANCES**



ADP5E...	CAP. I • 41
"D19" DC SOLENOIDS	CAP. I • 41
ADP5V...	CAP. I • 43
"D19" DC SOLENOIDS	CAP. I • 45

**FLOW DIVERSION VALVES**



CDL046... "OEM MACHINERY"	CAP. I • 66
CDL066... "OEM MACHINERY"	CAP. I • 68
ADL066... "OEM MACHINERY"	CAP. I • 69
BDL066... "OEM MACHINERY"	CAP. I • 70
CDL106... "OEM MACHINERY"	CAP. I • 71
ADL106... "OEM MACHINERY"	CAP. I • 72
"A09" AND "D15" DC COILS	CAP. I • 73
"40W" AND "A16" DC COILS	CAP. I • 74



### CETOP 2/NG04

AD2E...	CAP. I • 4
"A09" DC COILS	CAP. I • 4
STANDARD CONNECTORS	CAP. I • 20

## DIRECTIONAL CONTROL VALVES CETOP 2/NG4

The directional control valves NG4 are designed for subplate mounting with an interface in accordance with UNI ISO 4401 - 02 - 01 - 0 - 94 standard (ex CETOP R 35 H 4.2-4-02), and are the smallest on the market in their category whilst still featuring excellent performance.

The use of solenoids with wet armatures ensures quiet operation, means that dynamic seals are no longer required and important levels of counter-pressure are accepted on the return line. The solenoid's tube is screwed at valve body directly, while a locking ring nut seal the coil in right position.

**The cast body** with a great care in the design and production of the ducts of the 5 chambers have made it possible to improve the spools allowing relatively high flow rate with low pressure drops ( $\Delta p$ ).

The spool rest positions are obtained by means of springs which centre it when there is no electrical impulse. The solenoids are constructed to DIN 40050 standards and are supplied by means of DIN 43650 ISO 4400 standard connectors which, suitably assembled, ensure a protection class of IP 65.

The solenoid coils are normally arranged for DIN 43650 ISO 4400 type connectors (standard version). On request, could be available the following coil connection variants: AMP Junior connections; flying leads connections, with or without integrated diode; Deutsch connections with bidirectional integrated diode.

The supply may be in either DC or AC form (with the use of a connector and rectifier) in most common voltage.

The valves are designed for use with DIN 51524 standard hydraulic mineral oils and it is recommended that filters should be fitted to ensure a maximum contamination level of class 10 in accordance with NAS 1638,  $\beta_{25} \geq 75$ .

### PRESSURE DROPS

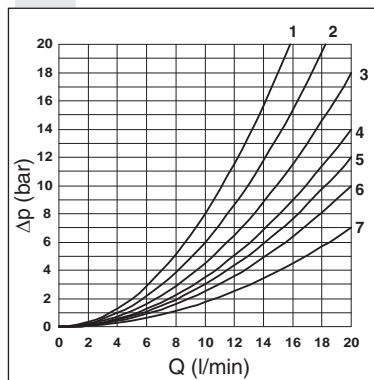

Spool type	Connections				
	P → A	P → B	A → T	B → T	P → T
01	4	4	6	6	
02	6	6	7	7	5
03	4	4	7	7	
04	1	1	2	2	3
05	6	6	4	4	
66	5	5	5	7	
06	5	5	7	5	
15	4	4	4	4	
16	5	5	6	6	
20*	5	5	6	6	

Curve No.

\* = with energized spool

The diagram at the side shows the pressure drop curves for spools during normal usage. The fluid used is a mineral based oil with a viscosity of 46 mm<sup>2</sup>/s at 40°C; the tests have been carried out at a fluid temperature of 40°C. For higher flow rates than those in the diagram the losses will be those expressed by the following formula:

$$\Delta p_1 = \Delta p \times (Q_1/Q)^2$$

where  $\Delta p$  will be the value for the losses for a specific flow rate Q which can be obtained from the diagram,  $\Delta p_1$  will be the value of the losses for the flow rate Q<sub>1</sub> that is used.

### ORDERING CODE

AD	Directional valve
2	CETOP 2/NG4
E	Electrical operator
**	Spool (tables next page)
*	Mounting (table 1 next page)
*	Voltage (table 2 next page)
**	Variants (table 3 next page)
3	Serial No.

# DIRECTIONAL CONTROL VALVES CETOP 2/NG4

**TAB. 1 MOUNTING**

STANDARD	
<b>C</b>	
<b>D</b>	
<b>E</b>	
<b>F</b>	
SPECIALS (WITH PRICE INCREASING)	
<b>G</b>	
<b>H</b>	
<b>I</b>	
<b>L</b>	
<b>M</b>	

**TAB.3 - VARIANTS**

VARIANT	CODE
No variant (without connectors)	S1(*)
Viton	SV(*)
Emergency button	ES(*)
Rotary emergency button	P2(*)(**)
AMP Junior connection	AJ(*)
Solenoid with flying leads (250 mm)	FL
Solenoid with flying leads (130 mm) integrated diode	LD
Deutsch connection with bidir. diode	CX
Coil 8W (only 24V)	8W
Other variants available on request.	

(\*) Coils with Hirschmann and AMP Junior connection supplied without connectors. The connectors can be ordered separately, CAP. I • 20.

(\*\*) P2 Emergency tightening torque max. 6÷9 Nm / 0.6 ÷ 0.9 Kgm with CH n. 22

**TAB.2 - A09 (27 W) COIL**

DC VOLTAGE **	
<b>L</b>	12V
<b>M</b>	24V
<b>N</b>	48V*
<b>P</b>	110V*
<b>Z</b>	102V*
<b>X</b>	205V*
<b>W</b>	Without DC coils

115Vac/50Hz  
120Vac/60Hz  
with rectifier

230Vac/50Hz  
240Vac/60Hz  
with rectifier

Voltage codes are not stamped on the plate, they are readable on the coils.

- Mounting type **D** is only for solenoid valves with detent
- In case of mounting **D** with detent, the supply to solenoid must be longer than 100 ms.
- The AMP Junior coil, the Deutsch coil with bidirectional diode and the coil with flying leads (with or without diode) coils are available in 12V or 24V DC voltage only.

\* Special voltage  
\*\* Technical data see page CAP. I • 4

**LIMITS OF USE (MOUNTING C-E-F)**

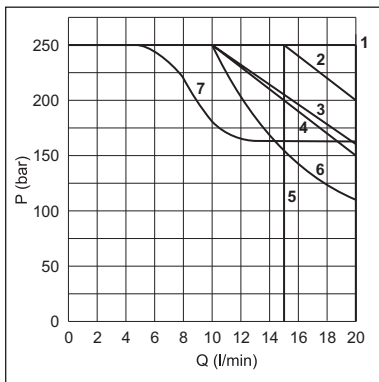

Spool Type	
01	1
02	3
03	1
04	4
05	1
66	1
06	1
15	1(7*)
16	2(6*)
20	5

(6\*) = 16 spool used as 2 or 3 way, follow the curve n°4  
(7\*) = with 8W coil

The tests have been carried out with solenoids at operating temperature and a voltage 10% less than rated voltage with a fluid temperature of 40°C. The fluid used was a mineral oil with a viscosity of 46 mm<sup>2</sup>/s at 40°C. The values in the diagram refers to tests carried out with the oil flow in two directions simultaneously (e.g. from P to A and at the same time B to T). In case of valve 4/2 or 4/3 used with flow in one direction only, the limits of use could have variations which may even be negative.

**Medium switching times** Energizing: 20 ms  
De-energizing: 40 ms

Tests have been carried out by spool normally closed with flow of 10 l/min at 125 bar and a 100% supply, warm standard coil and without any electronic components. These values are indicative and depend on the following parameters: the hydraulic circuit, the fluid used and the variation of pressure, flow and temperature.

**NOTE: Limits of use are available for C, E, F mounting.**

**STANDARD SPOOLS**

TWO SOLENOIDS, SPRING CENTRED "C" MOUNTING			
Spool Type		Covering	Transient position
01		+	
02		-	
03		+	
04*		-	
05		+	
66		+	
06		+	

**ONE SOLENOID, SIDE A "E" MOUNTING**

Spool Type		Covering	Transient position
01		+	
02		-	
03		+	
04*		-	
05		+	
66		+	
06		+	
15		-	
16		+	

**ONE SOLENOID, SIDE B "F" MOUNTING**

Spool Type		Covering	Transient position
01		+	
02		-	
03		+	
04*		-	
05		+	
66		+	
06		+	
15		-	
16		+	

**TWO SOLENOIDS "D" MOUNTING**

Spool Type		Covering	Transient position
20*		+	

\* SPOOLS WITH PRICE INCREASING



## ADC3... DIRECTIONAL CONTROL VALVES CETOP 3

### SOLENOID OPERATED WITH REDUCED OVERALL SIZE



#### ADC3E...

"A09" DC COILS	CAP. I • 7
STANDARD CONNECTORS	CAP. I • 20

The NG6 directional control valves are designed for subplate mounting with an interface in accordance with UNI ISO 4401 - 03 - 02 - 0 - 94 standard (ex CETOP R 35 H 4.2-4-03).

The use of solenoids with wet armatures allows an extremely safe construction completely dispensing with the need for dynamic seal. The solenoid tube is screwed directly onto the valve casting whilst the coil is kept in position by a ring nut.

The operation of the directional valve is electrical. The centring is achieved by means of calibrated length springs which, once the impulse is over, immediately reposition the spool in the neutral position. To improve the valve performance, different springs are used for each spool.

The solenoids, constructed with a protection class of IP65 in accordance with BS 5490 standards, are available in direct current form and different voltage. The electrical controls are equipped with an emergency manual control inserted in the tube.

The ADC3 valve uses shorter solenoids than the standard AD.3.E to reduce the overall dimensions.

The solenoid coils are normally arranged for DIN 43650 ISO 4400 type connectors (standard version). On request, could be available the following coil connection variants: AMP Junior connections; flying leads connections, with or without integrated diode; Deutsch connections with bidirectional integrated diode.

The recommended fluids are hydraulic mineral based oils in accordance with DIN 51524 and it is recommended that filters should be fitted to ensure a maximum contamination level of class 10 in accordance with NAS 1638,  $\beta_{25} \geq 75$ .

Max. pressure ports P/A/B/T	250 bar
Max flow	30 l/min
Max excitation frequency	3 Hz
Duty cycle	100% ED
Fluid viscosity	10 ÷ 500 mm <sup>2</sup> /s
Fluid temperature	-25°C ÷ 75°C
Ambient temperature	-25°C ÷ 60°C
Max contamination level	class 10 in accordance with NAS 1638 with filter $\beta_{25} \geq 75$
Weight with one DC solenoid	1,25 Kg
Weight with two DC solenoids	1,5 Kg

#### PRESSURE DROPS

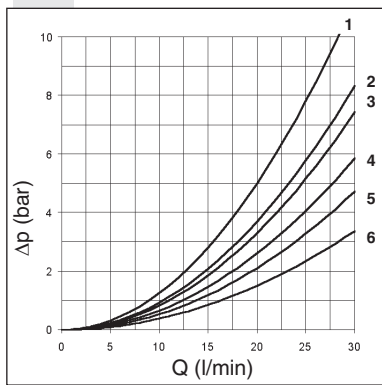

Spool type	Connections				
	P→A	P→B	A→T	B→T	P→T
01	4	4	4	4	
02	6	6	6	6	6
03	4	4	6	6	
04	3	3	2	2	5
15E-16E	6	3	1	5	
15F-16F	3	6	5	1	
	Curve No.				

The diagram at the side shows the pressure drop curves for spools during normal usage. The fluid used is a mineral oil with a viscosity of 46 mm<sup>2</sup>/s at 40 C°; the tests have been carried out at a fluid temperature of 40 C°. For higher flow rates than those in the diagram, the losses will be those expressed by the following formula:

$$\Delta p_1 = \Delta p \times (Q_1/Q)^2$$

where  $\Delta p$  will be the value for the losses for a specific flow rate Q which can be obtained from the diagram,  $\Delta p_1$  will be the value of the losses for the flow rate Q<sub>1</sub> that is used.

# ADC3... SOLENOID OPERATED WITH REDUCED OVERALL SIZE CETOP 3/NG6

1

## ORDERING CODE

<b>ADC</b>	Directional valve
<b>3</b>	CETOP 3/NG6
<b>E</b>	Electrical operator
<b>**</b>	Spool (tables at the side)
<b>*</b>	Mounting (table 1)
<b>*</b>	Voltage (table 2)
<b>**</b>	Variants (table 3)
<b>1</b>	Serial No.

## TAB.1 - MOUNTING

STANDARD	
<b>C</b>	
<b>E</b>	
<b>F</b>	
SPECIALS (WITH PRICE INCREASING)	
<b>G</b>	
<b>H</b>	

## STANDARD SPOOL

TWO SOLENOIDS, SPRING CENTRED "C" MOUNTING			
Spool type		Covering	Transient position
<b>01</b>		+	
<b>02</b>		-	
<b>03</b>		+	
<b>04*</b>		-	

## ONE SOLENOID, SIDE A "E" MOUNTING

Spool type		Covering	Transient position
<b>01</b>		+	
<b>02</b>		-	
<b>03</b>		+	
<b>04*</b>		-	
<b>15</b>		-	
<b>16</b>		+	

## ONE SOLENOID, SIDE B "F" MOUNTING

Spool type		Covering	Transient position
<b>01</b>		+	
<b>02</b>		-	
<b>03</b>		+	
<b>04*</b>		-	
<b>15</b>		-	
<b>16</b>		+	

## TAB.2 - A09 (27 W) COIL

DC VOLTAGE **	
<b>L</b>	12V
<b>M</b>	24V
<b>N</b>	48V*
<b>P</b>	110V*
<b>Z</b>	102V*
<b>X</b>	205V*
<b>W</b>	Without DC coils

Diagram showing a coil with two terminals and a switch symbol.

Voltage codes are not stamped on the plate, they are readable on the coils.

• The AMP Junior coil, the Deutsch coil with bidirectional diode and the coil with flying leads (with or without diode) coils are available in 12V or 24V DC voltage only.

\* Special voltage  
\*\* Technical data see page CAP. I • 7

## TAB.3 - VARIANTS

Variant	Code
No variant (without connectors)	S1(*)
Viton	SV(*)
Emergency button	ES(*)
Rotary emergency button	P2(*)(**)
Rotary emergency button (180°)	R5(*)(**)
Variant with lever for emergency button	LF(*)
AMP Junior connection	AJ(*)
Coil with flying leads (250 mm)	FL
Coil with flying leads (130 mm) with diode	LD
Deutsch connection with bidirectional diode	CX

Other variants available on request.

(\*) Coils with Hirschmann and AMP Junior connection supplied without connectors. The connectors can be ordered separately, CAP. I • 20.

(\*\*) **P2 and R5 Emergency** tightening torque max. **6÷9 Nm / 0.6 ÷ 0.9 Kgm** with CH n. 22

## LIMITS OF USE (MOUNTING C-E-F)

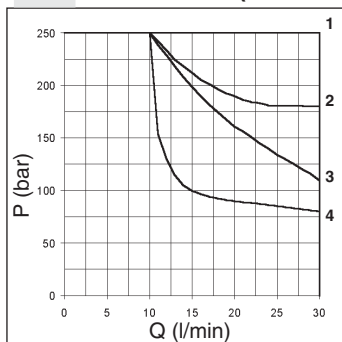

Spool type	n° curve
01	2
02	1
03	3
04	3
15	4
16	1(4*)

(4\*) = 16 spools used for 3 way valve, follow the curve n°4

The tests have been carried out with solenoids operating temperature and a voltage 10% less than rated voltage with a fluid temperature of 50 C°. The fluid used was a mineral oil with a viscosity of 46 mm²/s at 40 degrees C. The values in the diagram refer to tests carried out with the oil flow in two directions simultaneously (e.g. from P to A and at the same time B to T).

In the cases where valves 4/2 and 4/3 are used with the flow in one direction only, the limits of use could have variations which may even be negative (See curve No 4 and Spool No 16). The tests were carried out with a counter-pressure of 2 bar at T port.



# ADC3... SOLENOID OPERATED WITH REDUCED OVERALL SIZE CETOP 3/NG6

## OVERALL DIMENSIONS

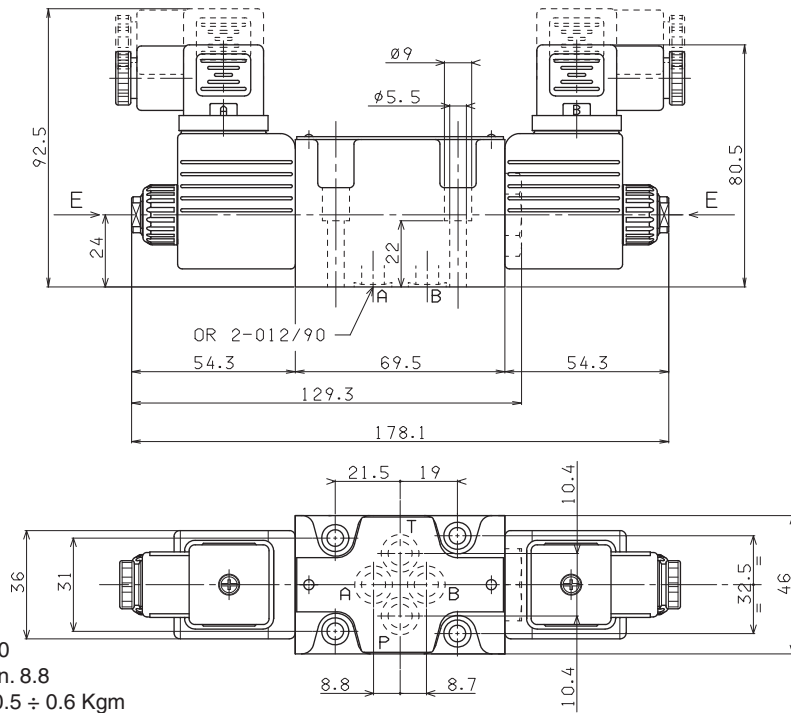

E = Manual override

Fixing screws UNI 5931 M5x30  
with material specifications min. 8.8  
Tightening torque 5 ÷ 6 Nm / 0.5 ÷ 0.6 Kgm

1



## A09 DC COILS

Type of protection (in relation to connector used)	IP 65
Number of cycle	18.000/h
Supply tolerance	±10%
Ambient temperature	-30°C ÷ 60°C
Duty cycle	100% ED
Insulation class wire	H
Weight	0,215 Kg

• The AMP Junior coil, the Deutsch coil with bidirectional diode and the coil with flying leads (with or without diode) coils are available in 12V or 24V DC voltage only.

VOLTAGE (V)	MAX WINDING TEMPERATURE (AMBIENT TEMPERATURE 25°C)	RATED POWER (W)	RESISTANCE AT 20°C (OHM) ±7%
12V	123°C	27	5.3
24V	123°C	27	21.3
48V*	123°C	27	85.3
102V(**)**	123°C	27	392
110V(**)**	123°C	27	448
205V(**)**	123°C	27	1577

\* Special voltages

\*\* The european low voltage directive is applied to electrical equipments used at a nominal voltages between 50 and 1000 VAC or 75 and 1500 VDC. In conformity with the low directive each part of the manifold or the subplate on which the valve is mounted should be connected to a protective earth with a resistance less than 0.1 ohms.

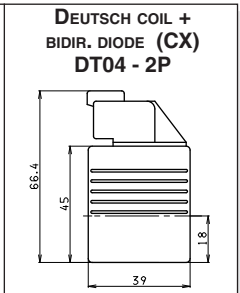
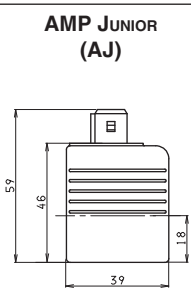

**EMERGENCY (COILS WITH HIRSCHMANN CONNECTION)**

MANUAL WITHOUT CONNECTOR (ES) MANUAL WITH CONNECTOR (E1)	ROTARY WITHOUT CONNECTOR (P2*) ROTAN ROTARY TE WITH CONNECTOR (P1*)	ROTARY 180° WITHOUT CONNECTOR (R5*) ROTARY 180° WITH CONNECTOR (P5*)	FLYING LEADS (FL) LEADS + DIODE (LD)

(\*) Emergency tightening torque max. 6÷9 Nm / 0.6 ÷ 0.9 Kgm with CH n. 22



### CETOP 3/NG06

STANDARD SPOOLS	CAP. I • 10
AD3E...	CAP. I • 11
AD3E...J*	CAP. I • 12
AD3E...KJ	CAP. I • 13
AD3V...	CAP. I • 14
AD3L...	CAP. I • 15
OTHER OPERATOR	CAP. I • 16
AD3P...	CAP. I • 17
AD3O...	CAP. I • 17
AD3M...	CAP. I • 18
AD3D...	CAP. I • 18
"D15" DC COILS	CAP. I • 19
"B14" AC SOLENOIDS	CAP. I • 19
STANDARD CONNECTORS	CAP. I • 20
"LE" VARIANTS	CAP. I • 21
L.V.D.T.	CAP. I • 22

## DIRECTIONAL CONTROL VALVES CETOP 3/NG6

### INTRODUCTION

The directional control valves NG6 are designed for subplate mounting with an interface in accordance with UNI ISO 4401 - 03 - 02 - 0 - 94 standard (ex CETOP R 35 H 4.2-4-03), and can be used in all fields on account of their high flow rate and pressure capacities combined with compact overall dimensions.

The use of solenoids with wet armatures allows a very practical, safe construction completely dispensing with dynamic seals; the solenoid tube is screwed directly onto the valve chest whilst the coil is kept in position by means of a lock nut.

The special, precise construction of the ports and the improvement of the spools enables relatively high flow rates to be accommodated with a minimal pressure drop ( $\Delta p$ ).

The operation of the directional valves may be electrical, pneumatic, oleodynamic, mechanical or lever.

The centre position is obtained by means of calibrated length springs which reposition the spool in the centre or end of travel position once the action of the impulse is over.

The solenoids are constructed with a protection class of IP66 to DIN 40050 standards and are available in either AC or DC form in different voltage and frequencies.

The new type DC coil "D15", of cause their high performance, allows to increasing the limits of use respect to last series.

All types of electrical control are available, on request, with different types of manual emergency controls.

The solenoid coils are normally arranged for DIN 43650 ISO 4400 type connectors; is available on request these variant coils: with AMP Junior connections, with AMP junior and integrated diode, with Deutsch DT04-2P connections or solenoid with flying leads. Connectors with built in rectifiers or pilot lights are also available.

The valves are designed for use with DIN 51524 standard hydraulic mineral oils and it is recommended that filters should be fitted to ensure a maximum contamination level of class 10 in accordance with NAS 1638,  $\beta_{25} \geq 75$ .

### PRESSURE DROPS

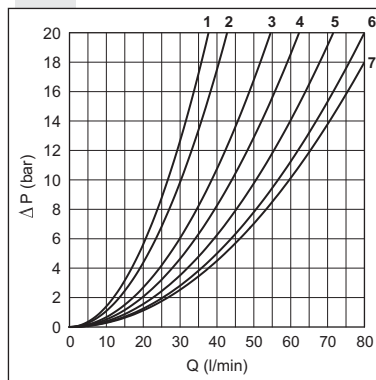

The diagram at the side shows the pressure drop curves for spools during normal usage. The fluid used is a mineral oil with a viscosity of 46 mm<sup>2</sup>/s at 40°C; the tests have been carried out at a fluid temperature of 40°C. For higher flow rates than those in the diagram, the losses will be those expressed by the following formula:

$$\Delta p_1 = \Delta p \times (Q_1/Q)^2$$

where  $\Delta p$  will be the value for the losses for a specific flow rate  $Q$  which can be obtained from the diagram,  $\Delta p_1$  will be the value of the losses for the flow rate  $Q_1$  that is used.

Spool type	Connections				
	P→A	P→B	A→T	B→T	P→T
01	5	5	5	5	
02	7	7	7	7	6
03	5	5	6	6	
04	2	2	2	2	4
44	1	1	2	2	3
05	7	7	5	5	
06	5	5	7	5	
66	5	5	5	7	
07		2	6		
08	6	6			
09		5		5	

Curve No.

Spool type	Connections				
	P→A	P→B	A→T	B→T	P→T
10	5	5	5	5	
11	5			5	
22		5	5		
12		5		6	
13		5	6	6	
14	4	3	3	3	4
28	3	4	3	3	4
15-19*	5	5	6	6	
16	5	5	4	4	
17-21*	3	4			
20*	4	4	4	4	

Curve No.

(\*) Value with energized solenoid

# DIRECTIONAL CONTROL VALVES CETOP 3/NG6

## ORDERING CODE

<b>AD</b>	Directional valve
<b>3</b>	CETOP 3/NG6
<b>E</b>	Type of operator For other operator see next pages
<b>**</b>	Spool see page Cap. I • 10
<b>*</b>	Mounting type (table 1)
<b>*</b>	Voltage (table 2)
<b>**</b>	Variants (table 3)
<b>*</b>	Serial No.
<b>3</b> = Standard	
<b>4</b> = Only for RS - R6 - KJ - 7J variants	

## TAB.2 - VOLTAGE

AC SOLENOID B14 **	
<b>A</b>	24V/50-60 Hz
<b>B</b>	48V/50-60 Hz
<b>J</b>	115V/50Hz - 120V/60Hz
<b>Y</b>	230V/50Hz - 240V/60Hz
<b>K</b>	AC without coils
Other voltages available on request.	
DC COIL D15 (30W) **	
<b>L</b>	12V
<b>M</b>	24V
<b>V</b>	28V*
<b>N</b>	48V*
<b>Z</b>	102V*
<b>P</b>	110V*
<b>X</b>	205V*
<b>K</b>	DC without coils
<b>W</b>	DC without coils

115Vac/50Hz  
120Vac/60Hz  
with rectifier

230Vac/50Hz  
240Vac/60Hz  
with rectifier

Voltage codes are not stamped on the plate, their are readable on the coils.

## TAB.1- MOUNTING

STANDARD	
<b>C</b>	
<b>D</b>	
<b>E</b>	
<b>F</b>	
SPECIALS (WITH PRICE INCREASING)	
<b>G</b>	
<b>H</b>	
<b>I</b>	
<b>L</b>	
<b>M</b>	

• AMP Junior coils (with or without diode) and coils with flying leads and coils type Deutsch, are available in 12V or 24V DC voltage only.

• The coil with eCoat protection (RS variant) is available in 12V, 24V, 28V or 110V DC voltage only.

\* Special voltage

\*\* Technical data see page Cap. I • 19

• Mounting type **D** is only for valves with detent

• In case of mounting **D** with detent a maximum supply time of 2 sec is needed (only for AC coils).

## TAB.3 - VARIANTS

VARIANT	CODE	◆	PAGE
No variant (without connectors)	S1(*)		
Viton	SV (*)		
Emergency control lever for directional control valves type ADC3 and AD3E	LE-LF-AX-CE(*)	◆	Cap. I • 21
Emergency button	ES(*)		Cap. I • 19
Rotary emergency button	P2(*)		Cap. I • 19
Rotary emergency button (180°)	R5(*)		Cap. I • 19
Preset for microswitch (E/F/G/H mounting only) (see below note ◆)	MS(*)	◆	Cap. I • 11 - Cap. I • 15
5 micron clearance	SQ(*)	◆	
Spool movement speed control (only VDC) with ø 0.3 mm orifice	3S(*)	◆	Cap. I • 12
Spool movement speed control (only VDC) with ø 0.4 mm orifice	JS(*)	◆	Cap. I • 12
Spool movement speed control (only VDC) with ø 0.5 mm orifice	5S(*)	◆	Cap. I • 12
Spool movement speed control (only VDC) with ø 0.6 mm orifice	6S(*)	◆	Cap. I • 12
AMP Junior coil - for 12V or 24V DC voltage only	AJ(*)		Cap. I • 19
AMP Junior coil and integrated diode - for 12V or 24V DC voltage only	AD(*)		Cap. I • 19
Coil with flying leads (175 mm) - for 12V or 24V DC voltage only	SL		Cap. I • 19
Hirschmann coil eCoat surface treatment - for 12V, 24V, 28V or 110V DC voltage only	RS(*)		Cap. I • 19
Deutsch DT04-2P connection eCoat surface treatment - for 12V, 24V DC voltage only	R6		Cap. I • 19
High corrosion resistance valve - Hirschmann connector	KJ		Cap. I • 13
High corrosion resistance valve - Deutsch DT04-2P connector - for 12V, 24V DC voltage only	7J		Cap. I • 13
Deutsch DT04-2P coil - for 12V or 24V DC voltage only	CZ		Cap. I • 19

Other variants available on request.

◆ = Maximum counter-pressure on T port: 8 bar - Microswitch type AM1107 code V79000001 can be ordered separately.

◆ = Variant codes stamped on the plate

(\*) Coils with Hirschmann and AMP Junior connection supplied without connectors. The connectors can be ordered separately, Cap. I • 20.

**TWO SOLENOIDS, SPRING CENTRED "C" MOUNTING**

Spool type		Covering	Transient position
01		+	
02		-	
03		+	
04*		-	
44*		-	
05		+	
66		+	
06		+	
07*		+	
08*		+	
09*		+	
10*		+	
22*		+	
11*		+	
12*		+	
13*		+	
14*		-	
28*		-	

**ONE SOLENOID, SIDE A "E" MOUNTING**

Spool type		Covering	Transient position
01		+	
02		-	
03		+	
04*		-	
44*		-	
05		+	
66		+	
06		+	
08*		+	
10*		+	
12*		+	
15		-	
16		+	
17		+	
14*		-	
28*		-	

**DIRECTIONAL CONTROL VALVES  
STANDARD SPOOLS CETOP 3/NG6**

**NOTE**

(\*) Spool with price increasing

• With spools 15 / 16 / 17 only mounting E / F are possible

• 16 / 19 / 20 / 21 spool not planned for AD3E...J\*

• For lever operated the spools used are different.  
Available spools for this kind of valve see AD3L..

**ONE SOLENOID, SIDE B "F" MOUNTING**

Spool type		Covering	Transient position
01		+	
02		-	
03		+	
04*		-	
44*		-	
05		+	
66		+	
06		+	
08*		+	
09*		+	
10*		+	
22*		+	
12*		+	
13*		+	
07*		+	
15		-	
16		+	
17		+	
14*		-	
28*		-	

**TWO SOLENOIDS "D" MOUNTING**

Spool type		Covering	Transient position
19*		-	
20*		+	
21*		+	

# AD3E... DIRECTIONAL CONTROL VALVES SOLENOID OPERATED CETOP 3/NG6

1



Amax. counter-pressure of 8 bar at T is permitted for the variant with a microswitch (MS).  
 (\*) DC: Dynamic pressure allowed for 2 millions of cycles.  
 AC: Dynamic pressure allowed for 350.000 of cycles. For dynamic pressure of 100 bar are allowed 1 million cycles.

Max. pressure port P/A/B	350 bar
Max. pressure port T (for DC) see note (*)	250 bar
Max. pressure port T (for AC) see note (*)	160 bar
Max. flow	80 l/min
Max. excitation frequency	3 Hz
Duty cycle	100% ED
Fluid viscosity	10 ÷ 500 mm <sup>2</sup> /s
Fluid temperature	-25°C ÷ 75°C
Ambient temperature	-25°C ÷ 60°C
Max. contamination level	class 10 in accordance with NAS 1638 with filter β <sub>25</sub> ≥ 75
Weight with one DC solenoid	1,65 Kg
Weight with two DC solenoids	2 Kg
Weight with one AC solenoid	1,31 Kg
Weight with two AC solenoids	1,72 Kg

CALIBRATED DIAPHRAGMS (**)	
Ø mm	Code
blind	M52.05.0023/4
0.5	M52.05.0023/1
0.6	M52.05.0023/6
0.7	M52.05.0023/8
0.8	M52.05.0023
1.0	M52.05.0023/2
1.2	M52.05.0023/3
1.5	M52.05.0023/7
2.0	M52.05.0023/10
2.2	M52.05.0023/9
2.5	M52.05.0023/5

(\*\*) For high differential pressure please contact our technical department.

## OVERALL DIMENSIONS

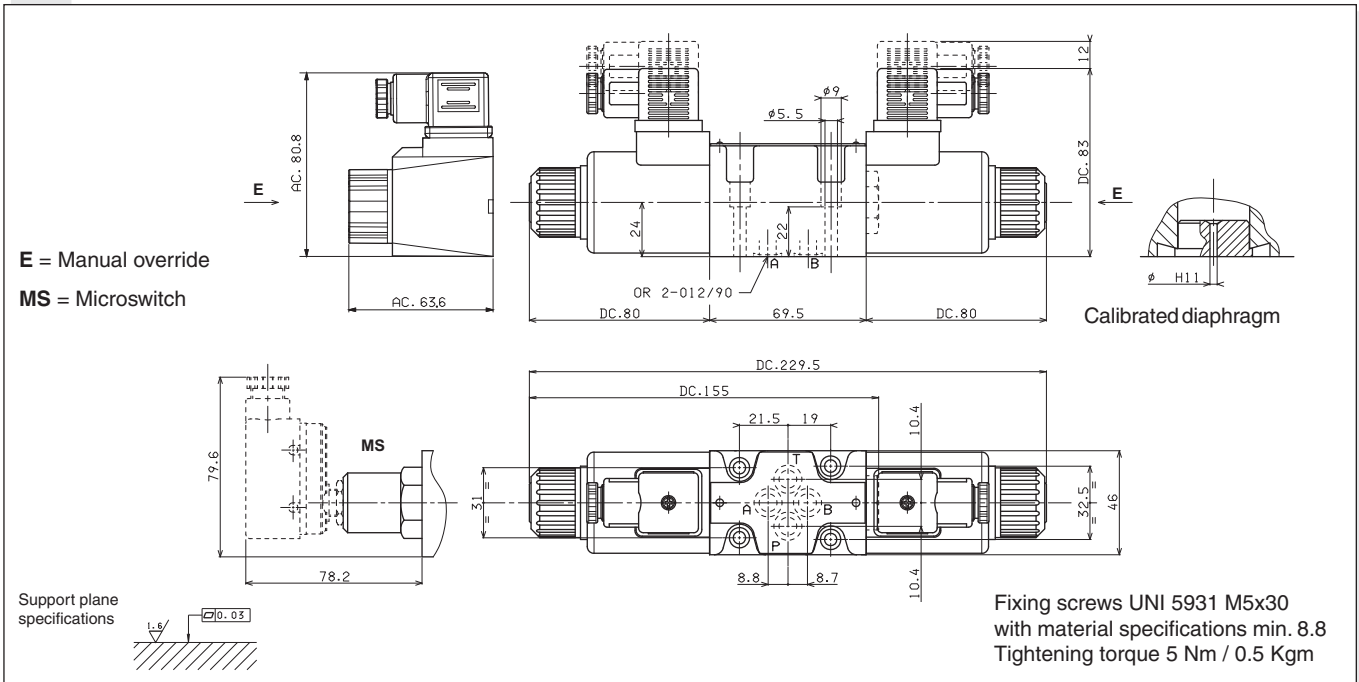

## LIMITS OF USE (MOUNTING C-E-F)

The tests have been carried out with solenoids at operating temperature and a voltage 10% less than rated voltage with a fluid temperature of 40°C. The fluid used was a mineral oil with a viscosity of 46 mm<sup>2</sup>/s at 40°C. The values in the diagram refers to tests carried out with the oil flow in two directions simultaneously T = 2 bar (e.g. from P to A and the same time B to T). In the case where valves 4/2 and 4/3 were used with the flow in one direction only, the limits of use could have variations which may even be negative. Rest times: the values are indicative and depend on following parameters: hydraulic circuit, fluid used and variations in hydraulic scales (pressure P, flow Q, temperature T). The limit of use for AC solenoids were detected with 50 Hz power.

Direct current:	Energizing	30 ÷ 50 ms.	Alternating current:	Energizing	8 ÷ 30 ms.
	De-energizing	10 ÷ 30 ms.		De-energizing	15 ÷ 55 ms.

**NOTE: The operating limits shown are valid for mountings C, E, F.**

### DIRECT CURRENT SOLENOIDS (DC)

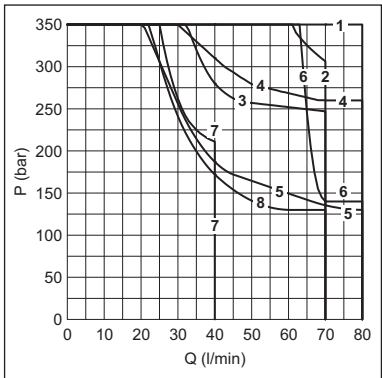

Spool type	Solenoids	
	DC	AC
01	1	9
02	1	9
03	3	10
04	2	15
44	1	9
05	1	16
06-66	5	13
11-22	4	17
14-28	7	12
15	8	14
16	6	11

Curves

### ALTERNATING CURRENT SOLENOIDS (AC)

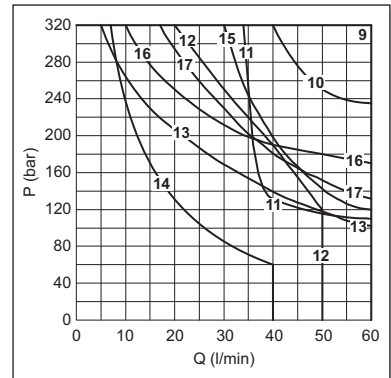

# AD3E...J\* VALVES WITH SPOOL MOVEMENT SPEED CONTROL VARIANT J\*

1

## Valves type AD3E...J\* with spool movement speed control

These ON-OFF type valves are used a lower spool movement speed than usual for conventional solenoid valves is required to prevent impacts which could adversely affect the smooth running of the system. The system consist of reducing the transfer section for the fluid from one solenoid to the other by means of calibrated orifices.

- This version can only be used with a direct current (DC) and also involves a **reduction in the limits of use so that we suggest to always test the valve in your application**

- To order AD3...J\* version valves, specify the orifices code.

- The operation is linked to a minimum counter-pressure on T line (1 bar min.)

- The switching time referred to the spool travel detected by a LVDT transducer can vary for the NG6 valve from a minimum of 100 to a maximum of 300 ms depending on 5 fundamental variables:

- 1) Diameter of the calibrated orifices (see table)
- 2) Hydraulic power for clearance referring to flow and pressure values through valve
- 3) Spool type
- 4) Oil viscosity and temperature
- 5) Counter-pressure at T line

Max. pressure ports P/A/B	320 bar
Max. pressure port T (*)	250 bar
Max. flow	30 l/min
Max. excitation frequency	2 Hz
Duty cycle	100% ED
Fluid viscosity	10 ÷ 500 mm <sup>2</sup> /s
Fluid temperature	-25°C ÷ 75°C
Ambient temperature	-25°C ÷ 60°C
Weight with one DC solenoid	1,65 Kg
Weight with two solenoids DC solenoids	2 Kg

(\*) Pressure dynamic allowed for 2 millions of cycles.

CALIBRATED ORIFICES AVAILABLE		
ø (mm)	M4x4	Code
0.3	M89.10.0028	3S (J3+S1)*
0.4	M89.10.0029	JS (J4+S1)*
0.5	M89.10.0006	5S (J5+S1)*
0.6	M89.10.0030	6S (J6+S1)*

\* Old code

- Possible mountings: C / E / F / G / H
- 16 / 19 / 20 / 21 spools not planned for AD3E...J\*

## OVERALL DIMENSIONS

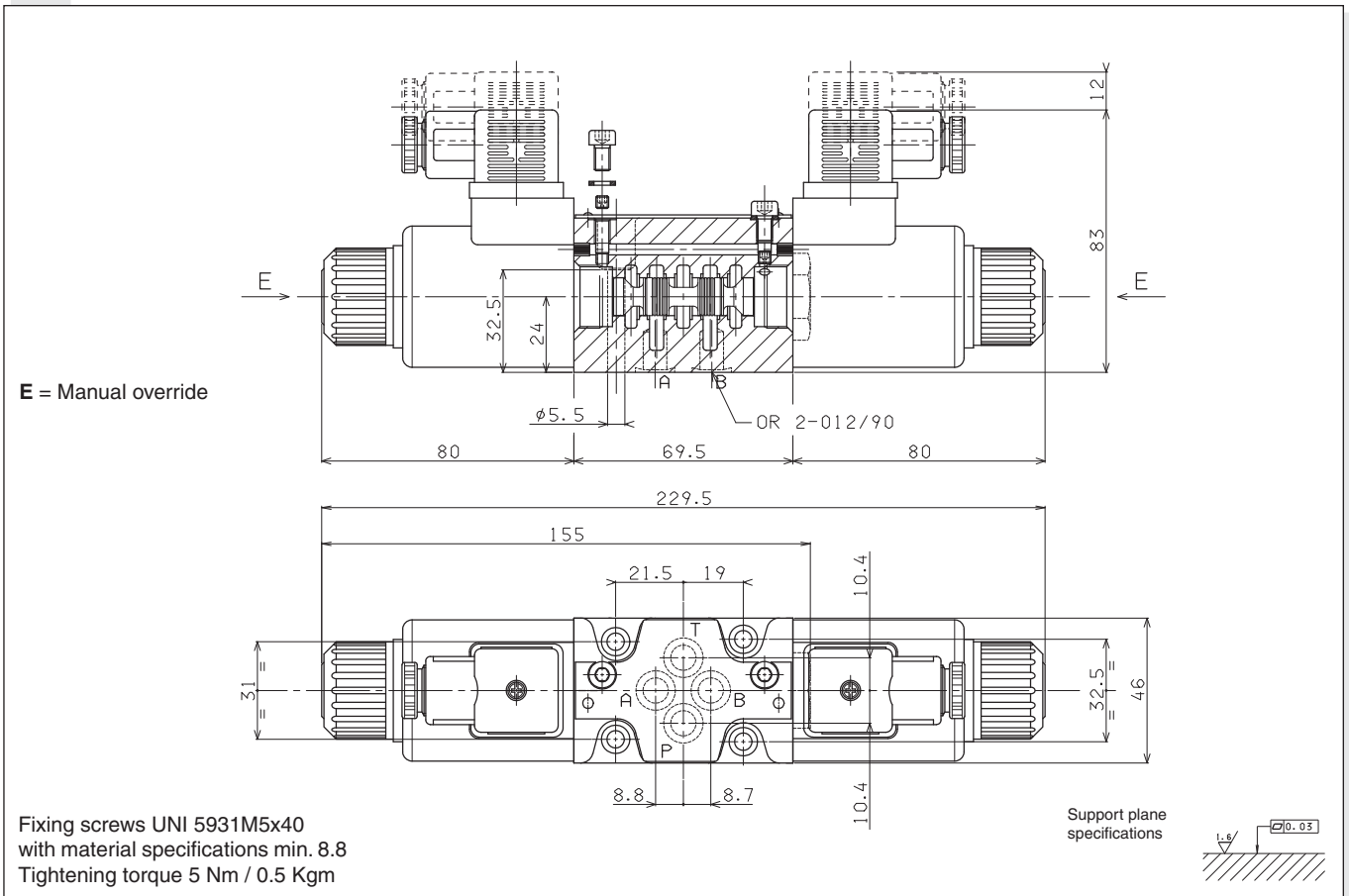

# AD3E...KJ / 7J HIGH CORROSION RESISTANCE

1



<b>AD3EJ..</b>	
"D15" DC COILS	CAP. I • 19
STANDARD CONNECTORS	CAP. I • 20

- This variant has a Zinc-Nickel surface treatment on metallic parts for a higher corrosion resistance
- Coil windings are sealed and outer metal housing has eCoat surface treatment
- The complete valve withstand more than 700 hours exposure of Salt Spray Test (test performer according to UNI EN ISO 9227 and evaluation according to UNI EN ISO10289).
- The plastic blind retainer is assembled as standard to protect the end surface of solenoid tube

## OVERALL DIMENSIONS

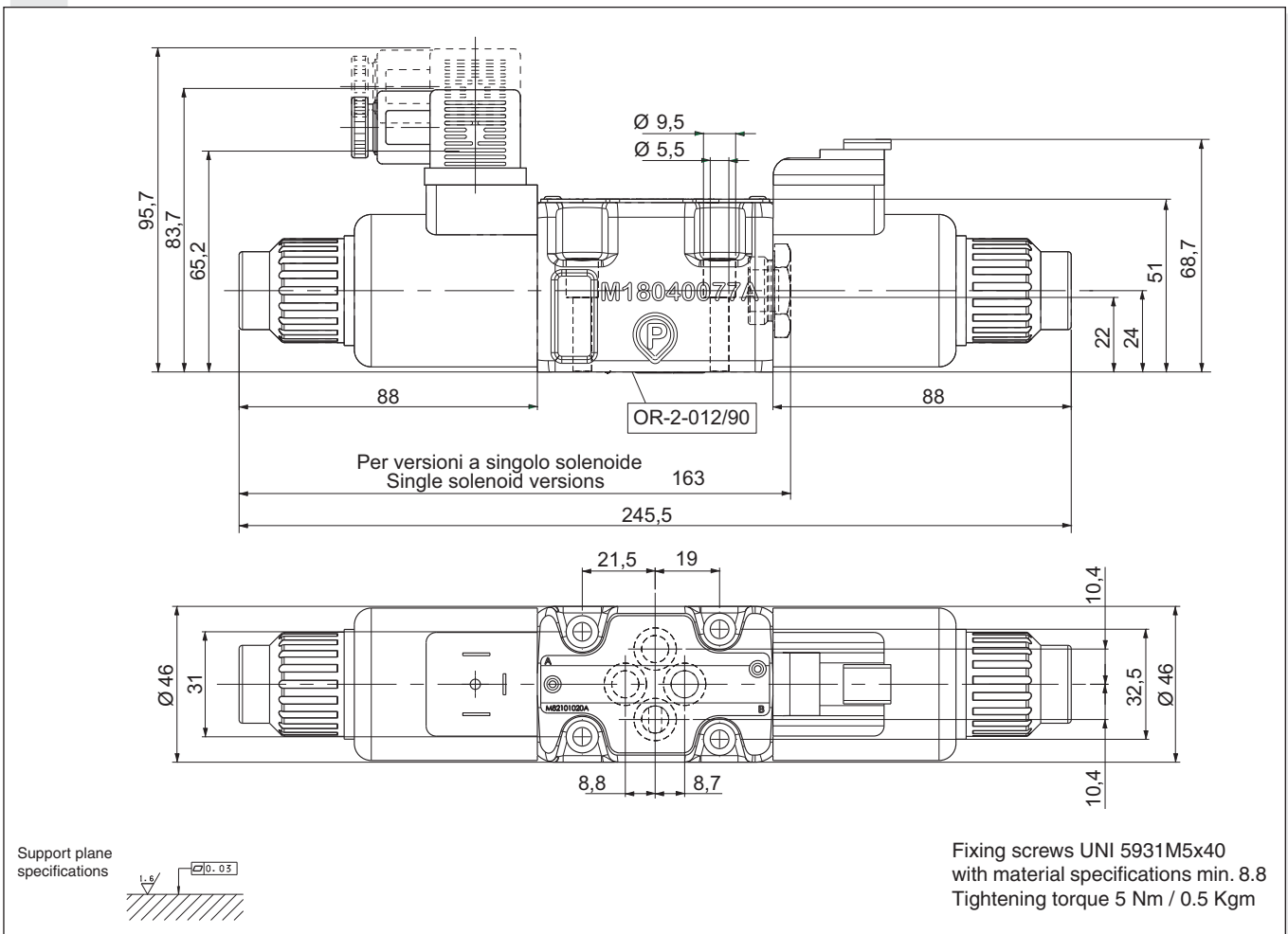



AD3V...	
"D15" DC COILS	CAP. I • 19
STANDARD CONNECTORS	CAP. I • 20
LVDT	CAP. I • 22

## AD3V... CETOP 3/NG6 WITH PROXIMITY SENSOR LVDT

The single solenoid directional valves type AD.3.V are used in applications where the monitoring of the position of the spool inside the valve is requested to manage the machine safety cycles in accordance with the accident prevention legislation. These directional valves are equipped with an horizontal positioned inductive sensor on the opposite side of the solenoid, which is capable of providing the first movement of the valve when the passage of a minimum flow is allowed. Integrated in safety systems, these valves intercept actuator movements that could be dangerous for the operators and for the machine.

Max. operating pressure ports P/A/B	350 bar
Max. operating pressure port T dynamic (see note*)	250 bar
Max. flow	60 l/min
Max. excitation frequency	3 Hz
Duty cycle	100% ED
Fluid viscosity	10 ÷ 500 mm <sup>2</sup> /s
Fluid temperature	-25°C ÷ 75°C
Ambient temperature	-25°C ÷ 60°C
Type of protection (in relation to connector used)	IP 66
Weight	1,7 Kg

(\* ) Pressure dynamic allowed for 2 millions of cycles.

- Possible mountings: E / F / H
- The valve is supplied with DC solenoid only

### ORDERING CODE

<b>AD</b>	Directional control valve
<b>3</b>	CETOP 3/NG6
<b>V</b>	Directional valve with single solenoid and LVDT proximity sensor
<b>***</b>	Spool and mounting (table 1)
<b>*</b>	Voltage (table 2)
<b>**</b>	Variants (table 3)
<b>2</b>	Serial No.

**CE** registered mark for industrial environment with reference to the electromagnetic compatibility. European norms:  
 - EN50082-2 general safety norm - industrial environment  
 - EN 50081-1 emission general norm - residential environment

### PRESSURE DROPS

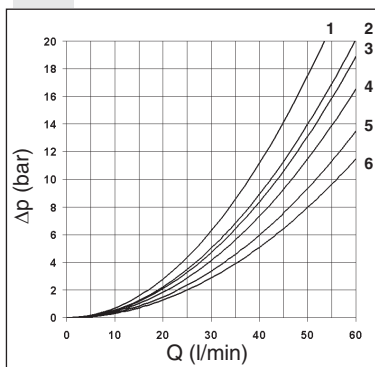

Spool type	Connections				
	P→A	P→B	A→T	B→T	P→T
01	5	5	5	5	
02	6	6	6	6	5
06	5	5	6	5	
16	5	5	4	4	
17	1	3			
66	5	5	5	6	
32	1	1	2	2	

Curves No.

The diagram at side shows the Δp curves for spool in normal usage. The fluid used is a mineral oil with a viscosity of 46 mm<sup>2</sup>/s at 40°C; the tests have been carried out at a fluid temperature of 40°C.

### TAB.2 - VOLTAGE

D15 COIL (30W) **	
L	12V
M	24V
V	28V*
N	48V*
Z	102V*
P	110V*
R	205V*
W	Without DC coils and connectors

115Vac/50Hz  
120Vac/60Hz with rectifier

230Vac/50Hz  
240Vac/60Hz with rectifier

Voltage codes are not stamped on the plate, they are readable on the coils.

\* Special voltage  
 \*\* Technical data see Cap. I • 19

### TAB1 - STANDARD SPOOLS FOR AD3V

POSSIBLE MOUNTING: E / F / H			
Spool type	Covering	Transient position	
01E	+		
01F	+		
02E	-		
06H*	+		
16E	+		
17F	+		
66F	+		
32E	+		

(\* ) Spool with price increasing

### TAB.3 - VARIANTS

No variant (without connectors)	S1(*)
Viton	SV(*)
Emergency button	ES(*)
Without proximity connector LVDT	S3
Without coils and proximity connector	S4
AMP Junior coil	AJ(*)
AMP Junior coil and integrated diode	AD(*)
Coil with flying leads (175mm)	SL
Deutsch DT04-2P Coil type	CZ

Other variants available on request.

(\* ) Coils with Hirschmann and AMP Junior connection supplied without connectors. The connectors can be ordered separately, Cap. I • 20.

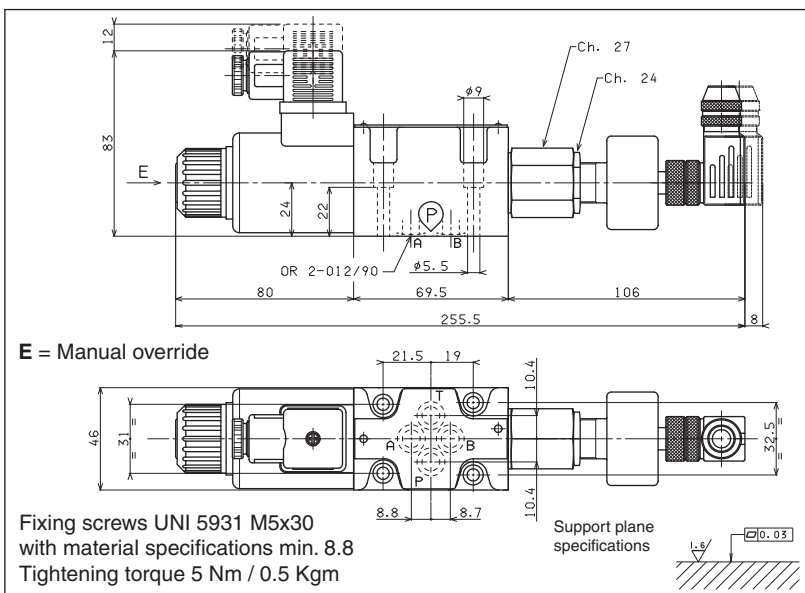



# AD3L... LEVER OPERATED CETOP 3/NG6

1



AD3L...

STANDARD SPOOLS

CAP. I • 10

Max. pressure ports P/A/B	320 bar
Max. pressure port T	160 bar
Max. flow	60 l/min
Lever angle	2 x 17°
Fluid viscosity	10 ÷ 500 mm <sup>2</sup> /s
Fluid temperature	-25°C ÷ 75°C
Ambient temperature	-25°C ÷ 60°C
Max. contamination level	class 10 in accordance with NAS 1638 with filter $\beta_{25} \geq 75$
Weight	1,2 Kg
Weight M1 variant	1,8 Kg

### ORDERING CODE

<b>AD</b>	Directional valve
<b>3</b>	CETOP 3/NG6
<b>L</b>	Lever operation
<b>**</b>	Spool type (see table 1) Spool symbol see CAP. I • 10
<b>*</b>	Mounting type (see table 2)
<b>*</b>	<b>Z</b> = Valve with lever <b>X</b> = Valve without lever
<b>*</b>	Variants (see table 3)
<b>4</b>	Serial No.

### TABLE 1 - SPOOLS TYPE

- For these valves spools are different from ones used on the other directional valves
- Available spools:  
01 / 02 / 03 / 04 / 05 / 06 / 66  
07 / 22 / 13 / 15 / 16 / 17

### TABLE 2 - MOUNTING TYPE

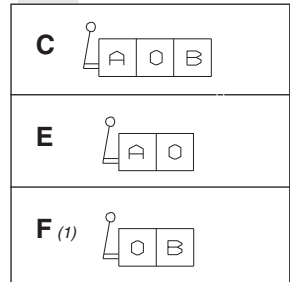

(1) For spools 15-16-17 the lever is mounted on site B

### OVERALL DIMENSIONS

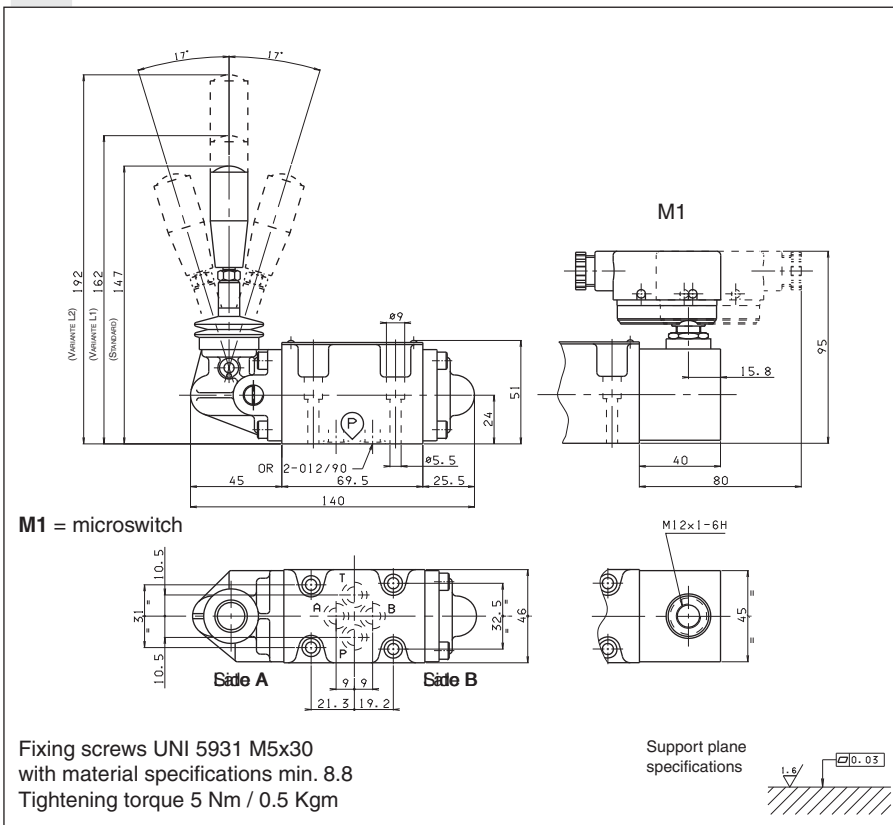

### TABLE 3 - VARIANTS TABLE

VARIANTS	CODE (♦)
No variant	00
Viton	V1
Preset for microswitch Microswitch type AM1107 code V79000001 can be ordered separately.	M1 (♦)
Preset for microswitch + Viton	MV (♦)
With detent (*) (mechanical connection) (Springs are different from those for standard versions)	D1 (♦)
Preset for microswitch + Detent (*)	MD (♦)
Lever length 162 mm	L1
Lever length 192 mm	L2
♦ Variant codes stamped on the plate	
(*) max. 150.000 cycles.	



## ALTRI COMANDI

STANDARD SPOOLS	CAP. I • 10
AD3P...	CAP. I • 17
AD3O...	CAP. I • 17
AD3M...	CAP. I • 18
AD3D...	CAP. I • 18

## DIRECTIONAL CONTROL VALVES

### OTHER OPERATOR CETOP 3/NG6

## INTRODUCTION

The directional control valves NG6 are designed for subplate mounting with an interface in accordance with UNI ISO 4401 - 03 - 02 - 0 - 94 standard (ex CETOP R 35 H 4.2-4-03), and can be used in all fields on account of their high flow rate and pressure capacities combined with compact overall dimensions.

The use of solenoids with wet armatures allows a very practical, safe construction completely dispensing with dynamic seals; the solenoid tube is screwed directly onto the valve chest whilst the coil is kept in position by means of a lock nut.

The special, precise construction of the ports and the improvement of the spools enables relatively high flow rates to be accommodated with a minimal pressure drop ( $\Delta p$ ).

The centre position is obtained by means of calibrated length springs which reposition the spool in the centre or end of travel position once the action of the impulse is over.

The valves are designed for use with DIN 51524 standard hydraulic mineral oils and it is recommended that filters should be fitted to ensure a maximum contamination level of class 10 in accordance with NAS 1638,  $B_{25} \geq 75$ .

## ORDERING CODE

<b>AD</b>	Directional valve
<b>3</b>	CETOP 3/NG06
<b>*</b>	Type of operator <b>P</b> = Pneumatic <b>O</b> = Oleodynamic <b>M</b> = Mechanically <b>D</b> = Direct mechanically (For other operator see past pages)
<b>**</b>	Spool (see CAP. I • 10)
<b>*</b>	Mounting type (tab.1)
<b>Z</b>	No voltage
<b>**</b>	Variants: <b>00</b> = no variant <b>V1</b> = Viton <b>H1</b> = Marine version (for AD3P only) <b>DI(*)</b> = Internal draining (for AD3O only)
<b>2</b>	Serial No.

## TAB.1 MOUNTING

STANDARD	
<b>C</b>	
<b>D</b>	
<b>E</b>	
<b>F</b>	
SPECIALS (WITH PRICE INCREASING)	
<b>G</b>	
<b>H</b>	
<b>I</b>	
<b>L</b>	
<b>M</b>	

• In case of **mounting D** with detent a maximum supply time of 2 sec is needed (only for AC coils).

(\*)The DI variant is recommended in the environments characterised by the presence of dust or any type of contamination.

## PRESSURE DROPS

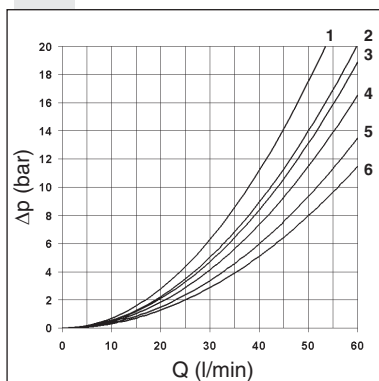

Spool type	Connections				
	P→A	P→B	A→T	B→T	P→T
01	5	5	5	5	
02	6	6	6	6	5
03	5	5	6	6	
04	1	1	2	2	4
05	5	5	5	5	
06	5	5	6	5	
66	5	5	5	6	
07		4	6		
08	6	6			
09		5		5	
10	5	5	5	5	

Curve No.

Spool type	Connections				
	P→A	P→B	A→T	B→T	P→T
11	4			6	
22		4	6		
12		5	6	6	
13		5	6	6	
14	2	1	1	1	2
28	1	2	1	1	2
15 - 19	4	4	6	6	
16	5	5	4	4	
17 - 21	1	3			
18	5	5			
20	4	4	4	4	

Curve No.

The diagram at the side shows the pressure drop curves for spools during normal usage. The fluid used is a mineral oil with a viscosity of 46 mm<sup>2</sup>/s at 40°C; the tests have been carried out at a fluid temperature of 40°C. For higher flow rates than those in the diagram, the losses will be those expressed by the following formula:

$$\Delta p_1 = \Delta p \times (Q_1/Q)^2$$

where  $\Delta p$  will be the value for the losses for a specific flow rate  $Q$  which can be obtained from the diagram,  $\Delta p_1$  will be the value of the losses for the flow rate  $Q_1$  that is used.

# AD3P... PNEUMATIC OPERATION TYPE VALVES CETOP 3/NG6

1



Max. pressure ports P/A/B	320 bar
Max. pressure port T	160 bar
Max. flow	60 l/min
Minimum operating pressure	2 + [0.027 x (pt*)] bar - see note
Maximum operating pressure	20 bar
Fluid viscosity	10 ÷ 500 mm <sup>2</sup> /s
Fluid temperature	-25°C ÷ 75°C
Ambient temperature	-25°C ÷ 60°C
Max. contamination level	class 10 in accordance with NAS 1638 with filter β <sub>25</sub> ≥ 75
Weight single pilot	1,2 Kg
Weight twin pilot	1,8 Kg

• Possible mountings:  
C/D/E/F/G/H/I/L/M

Ordering code see page before

(pt\*)= pressure at port T

### OVERALL DIMENSIONS

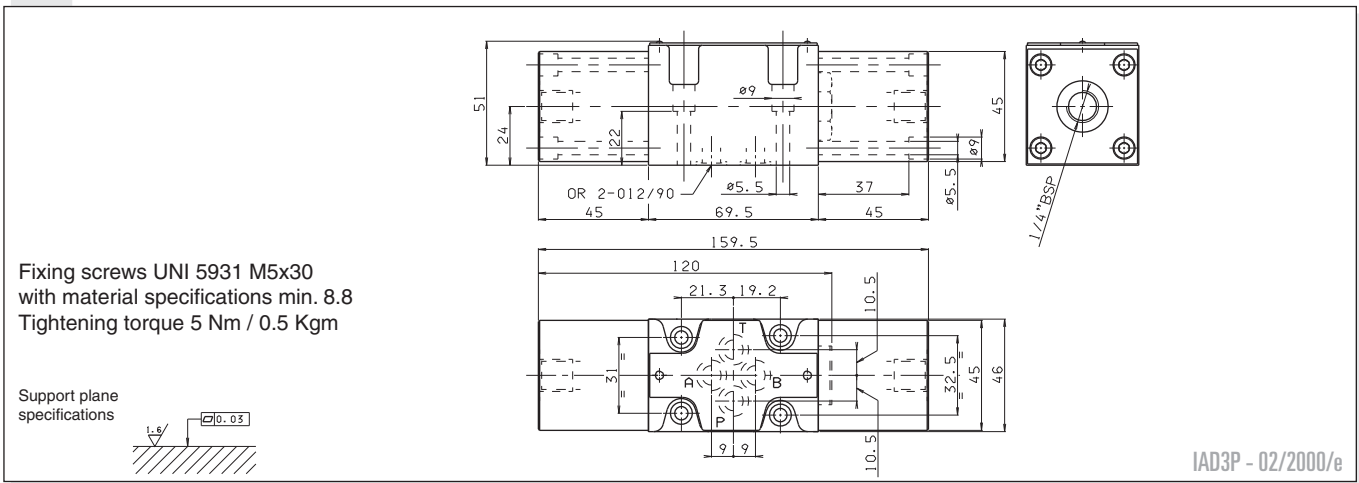

Fixing screws UNI 5931 M5x30 with material specifications min. 8.8  
Tightening torque 5 Nm / 0.5 Kgm

IAD3P - 02/2000/e

# AD30... OLEODYNAMIC OPERATION TYPE VALVES CETOP 3/NG6



Max. pressure ports P/A/B	320 bar
Max. pressure port T	160 bar
Max. flow	60 l/min
Minimum operating pressure	15 + [0.1 x (pt*)] bar - see note
Maximum operating pressure	250 bar
Fluid viscosity	10 ÷ 500 mm <sup>2</sup> /s
Fluid temperature	0°C ÷ 75°C
Ambient temperature	-25°C ÷ 60°C
Max. contamination level	class 10 in accordance with NAS 1638 with filter β <sub>25</sub> ≥ 75
Weight single pilot	1,5 Kg
Weight twin pilot	2,3 Kg

• Possible mountings:  
C/D/E/F/G/H/I/L/M

Ordering code see page before

(pt\*)= pressure at port "T".

The DI variant is recommended in the environments characterised by the presence of dust or any type of contamination.

**Further technical specifications (for DI variant only)**

Minimum operating pressure	[10 + (pt*)] bar - see note
Maximum operating pressure	250 bar
Max. piloting leakage	1 l/min

**Minimum pilot pressure depends on spool scheme, flow rate and pressure.**  
To allow the spool to return to neutral position, the pilot pressure must be below 3 bar.

### OVERALL DIMENSIONS

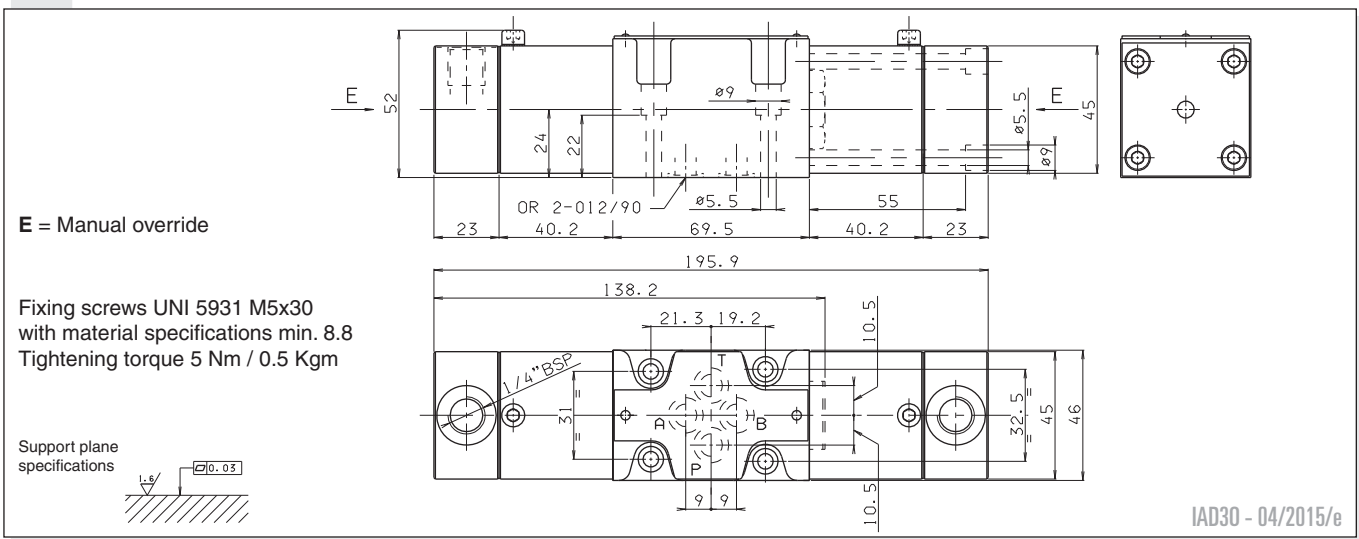

E = Manual override

Fixing screws UNI 5931 M5x30 with material specifications min. 8.8  
Tightening torque 5 Nm / 0.5 Kgm

IAD30 - 04/2015/e

# AD3M... MECHANICALLY OPERATED TYPE VALVES CETOP 3/NG6

1

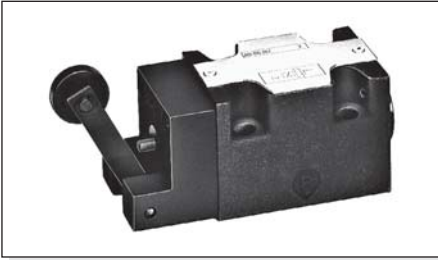

Max. pressure ports P/A/B	320 bar
Max. pressure port T	160 bar
Max. flow	60 l/min
Minimum operating force - see note (*)	2,5 Kg
Maximum operating force - see note (**)	13 Kg
Cam angle	27°
Fluid viscosity	10 ÷ 500 mm <sup>2</sup> /s
Fluid temperature	-25°C ÷ 75°C
Ambient temperature	-25°C ÷ 60°C
Max. contamination level	class 10 in accordance with NAS 1638 with filter $\beta_{25} \geq 75$
Weight	1 Kg

- Possible mountings: **E / F / G / H**
- Ordering code see page before
- Note:
  - (\*) In the absence of counter-pressure at port T
  - (\*\*) with a pressure of 160 bar at port T

## OVERALL DIMENSIONS

Stroke 12,4 mm  
Working stroke 3 mm

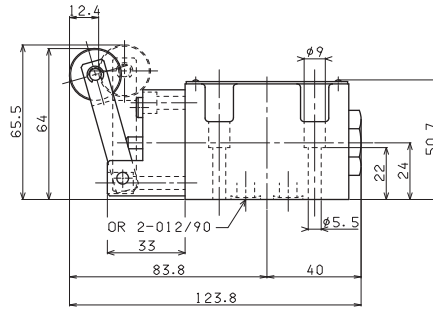

Fixing screws UNI 5931 M5x30 with material specifications min. 8.8  
Tightening torque 5 Nm / 0.5 Kgm

Support plane specifications

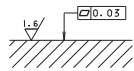

EAD3M - 02/2000/e

# AD3D... DIRECT MECHANICALLY OPERATED TYPE VALVES CETOP 3/NG6



Max. pressure ports P/A/B	320 bar
Max. pressure port T	20 bar
Max. flow	60 l/min
Operating force - see note (*)	6 Kg
Fluid viscosity	10 ÷ 500 mm <sup>2</sup> /s
Fluid temperature	0°C ÷ 75°C
Ambient temperature	-25°C ÷ 60°C
Max. contamination level	class 10 in accordance with NAS 1638 with filter $\beta_{25} \geq 75$
Weight	1,5 Kg

- Possible mountings: **E / F / G / H**
- Ordering code see page before
- Note:
  - (\*) In absence of counter-pressure at port T

## OVERALL DIMENSIONS

Stroke 6 mm  
Extra stroke 2 mm  
Working stroke 3 mm

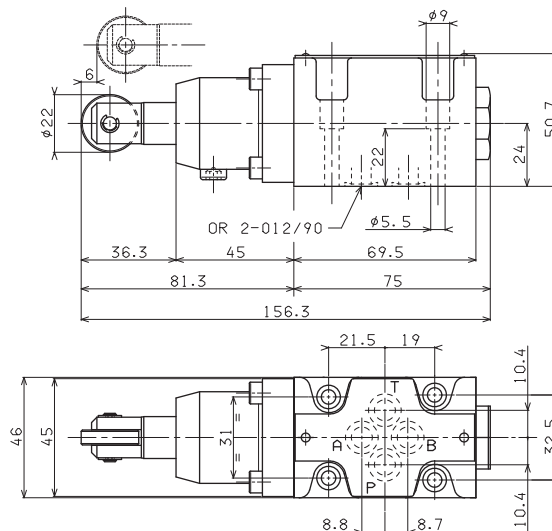

Fixing screws UNI 5931 M5x30 with material specifications min. 8.8  
Tightening torque 5 Nm / 0.5 Kgm

Support plane specifications

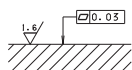

EAD3D - 02/2000/e



## "D15" DC COILS FOR CETOP 3

Type of protection (in relation to the connector used)	IP 66
Number of cycles	18.000/h
Supply tolerance	±10%
Ambient temperature	-25°C ÷ 60°C
Duty cycle	100% ED
Insulation class wire	H
Weight	0,354 Kg

- AMP Junior coils (with or without diode) and coils with flying leads and coils type Deutsch, are available in 12V or 24V DC voltage only.
- The pastic type coil (RS variant) is available in 12V, 24V, 28V or 110V DC voltage only.

1

VOLTAGE (V)	MAX WINDING TEMPERATURE (AMBIENT TEMPERATURE 25°C)	RATED POWER (W)	RESISTANCE AT 20°C (OHM) ±10%
12V	110°C	30	4.8
24V	110°C	30	18.8
28V*	110°C	30	25.6
48V*	110°C	30	75.2
102V(**)	110°C	30	340
110V(**)	110°C	30	387
205V(**)	110°C	30	1375

\* Special voltages

\*\* The european low voltage directive is applied to electronical equipments used at a nominal voltages between 50 and 1000 VAC or 75 and 1500 VDC. In conformity with the low directive each part of the manifold or the subplate on which the valve is mounted should be connected to a protective earth with a resistance less than 0.1 ohms.

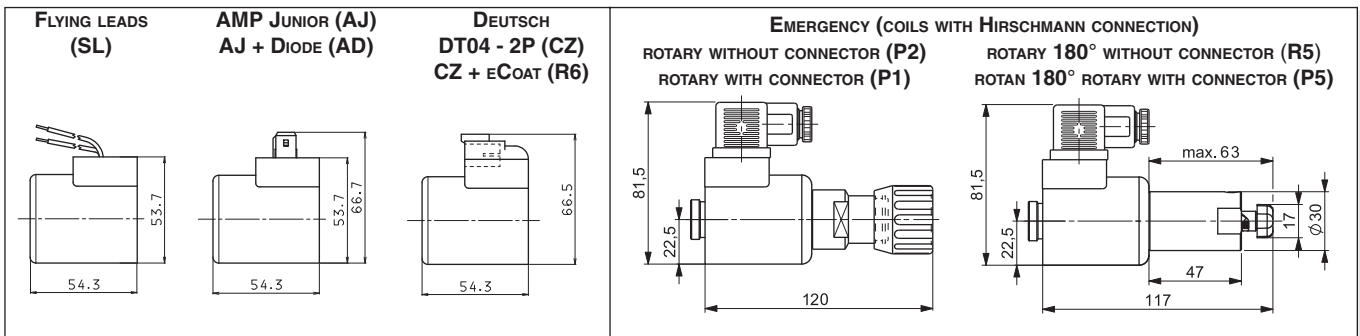
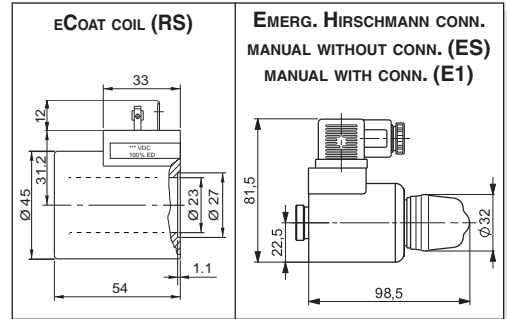

## "B14" AC SOLENOIDS FOR CETOP 3

Type of protection (in relation to the connector used)	IP 65
Number of cycles	18.000/h
Supply tolerance	+10% / -10%
Ambient temperature	-30°C ÷ 60°C
Duty cycle	100% ED
Insulation class wire	H
Weight	0,436 Kg

VOLTAGE (V)	MAX. WINDING TEMPERATURE (AMBIENT TEMPERATURE 25°C)	RESISTANCE AT 20°C (OHM) ±10%	RATED POWER. (VA)	PICKUP CURRENT (A)
24V/50Hz - 24V/60Hz	100°C - 96°C	1.7	54 - 40	5.6 - 5
48V/50Hz - 48V/60Hz	112°C - 98°C	6.8	45 - 34	5.3 - 5
115V/50Hz - 120V/60Hz *	133°C - 101°C	32.5	61 - 51	3.2 - 3.2
230V/50Hz - 240V/60Hz *	120°C - 103°C	134	62 - 52	1.6 - 1.6

\* The european low voltage directive is applied to electronical equipments used at a nominal voltages between 50 and 1000 VAC or 75 and 1500 VDC. In conformity with the low directive each part of the manifold or the subplate on which the valve is mounted should be connected to a protective earth with a resistance less than 0.1 ohms.

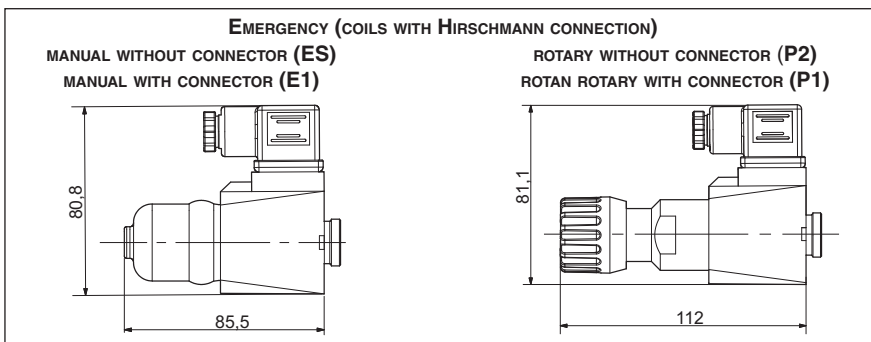

# CONNECTORS DIRECTIONAL CONTROL VALVES IN ACCORDANCE WITH DIN 43650/ISO4400

1

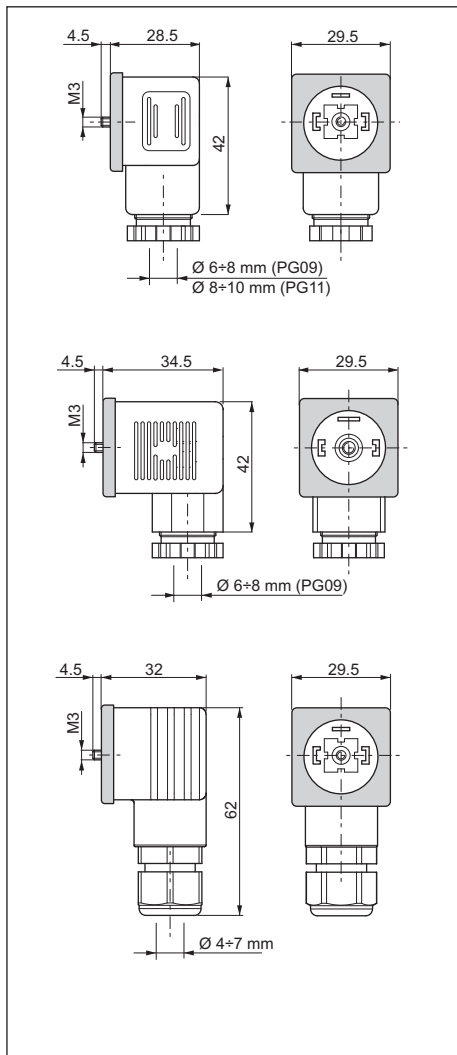

Connector	Protection level	Type	Cable gland	Code
Standard	IP65	Black color	PG09	V86 05 0002
		Grey color	PG09	V86 05 0004
		Black color	PG11	V86 05 0006
		Grey color	PG11	V86 05 0008
Lens cover with pilot light (bipolar led) (*)	IP65	12 VAC/VDC	PG09	V86 10 0018
		24 VAC/VDC	PG09	V86 10 0012
		115 VAC/VDC	PG09	V86 10 0020
		230 VAC/VDC	PG09	V86 10 0022

(\*) Don't use for proportional versions

Connector	Protection level	Type	Cable gland	Code
With rectifier (*) Inlet voltage 12÷230 VAC Outlet voltage 9÷205 VDC	IP65	Black color	PG09	V86 20 0002
		Grey color	PG09	V86 20 0004
Lens cover with pilot light (bipolar led) and rectifier (*) Inlet voltage 12÷230 VAC Outlet voltage 9÷205 VDC	IP65	12 VAC	PG09	V86 25 0018
		24 VAC	PG09	V86 25 0019
		48 VAC	PG09	V86 25 0020
		115 VAC	PG09	V86 25 0021
		230 VAC	PG09	V86 25 0022

(\*) Don't use for proportional versions

Connector	Protection level	Type	Cable gland	Code
With protection level IP67	IP67	Black color	—	V86 28 0001
		Grey color	—	V86 28 0002

### Electrical circuits

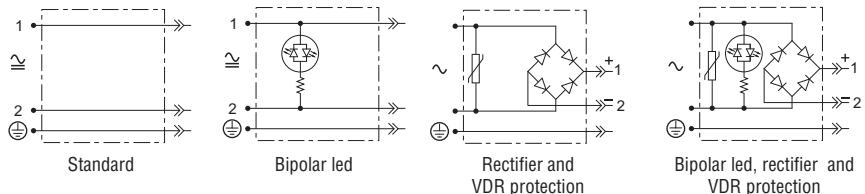

### ELECTRICAL FEATURES OF CONNECTORS

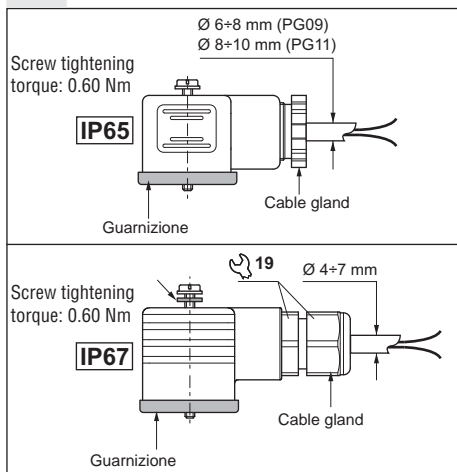

Description	IP65	IP67
AC rated voltage	Max. 250 V	Max. 250 V
DC rated voltage	Max. 300 V	Max. 300 V
Pin contact nominal current	10A	10A
Pin contact max. current	16A	16A
Max. section cable	1.5 mm <sup>2</sup>	1.5 mm <sup>2</sup>
Cable gland PG09 - M16x1,5	Ø cable 6 ÷ 8 mm	Ø cable 4 ÷ 7 mm
Cable gland PG11 - G 1/2" - M20x1,5	Ø cable 8 ÷ 10 mm	—
Protection level	IP65 EN60529	IP67 EN60529
Insulation class	VDE 0110-1/89	VDE 0110-1/89
Operating temperature	-40°C ÷ 90°C	-20°C ÷ 80°C

The degrees of protection indicate is guaranteed only if the connectors were properly mounted with his original seals.

### AMP JUNIOR CONNECTORS

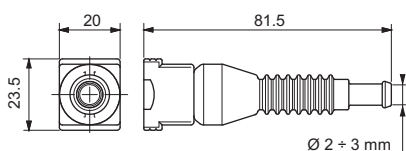

Connector	Type	Cable section	Pin contact max current	Code
AMP Junior connector Timer 2 contact	Black color	0,5 ÷ 1,5 mm <sup>2</sup>	10A	RKRC0808000



## VARIANTS (\*) - EMERGENCY CONTROL LEVER FOR DIRECTIONAL CONTROL VALVES (ADC/AD3E)

The emergency control lever for solenoid valves, represents a develop in terms of safety and flexibility among applied hydraulic components.

Thanks to his flexibility, the component was designed to be inserted between the valve body and the spool, providing total interchangeability between the different types of solenoid body valves. It is compatible with the standard CETOP 3 and stackable valves with threaded connections –G3/8” or 9/16-18UNF (SAE 6). The component is available for both directional control and proportional valves (for the last type of control please contact our Technical Department) As an emergency lever applied to solenoid valves, the control can be used as a safety device in conformity with the industry standards , also playing an useful role in the event of power cuts. The control can be used in agricultural and mobile fields; the manual action can be used to carry out periodic maintenance work on mobile components of the vehicle , in perfectly safe working conditions.

### (\*) VARIANTS

Variant	Description
LE	Standard coil with Hirschmann connection or without coil (W voltage)
LF	Standard coil without Hirschmann connection(*)
AX	AMP Junior coil(*)
CE	Deutsch coil

Other variants available on request.

(\*) Coils with Hirschmann and AMP Junior connection supplied without connectors. The connectors can be ordered separately, Cap. I • 20.

Max operating pressure port T:	
dynamic	160 bar
static	210 bar
Max operating pressure port P for series connection configuration	160 bar

- MOUNTING TYPE: C / F / H
- SPOOLS TYPE: 01/02/03\*/04/16/17/66

\* The spool 03 is allowed only on AD3E. Not permitted with ADC3

### HYDRAULIC SIMBOL

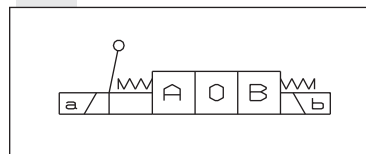

### MOUNTING COMPATIBILITY

CODE VALVE	DESCRIPTION	COIL	VOLTAGE
ADC3...	Directional control valve	A09	27 W
AD3E...	Directional control valve	D15	30 W

### OVERALL DIMENSION

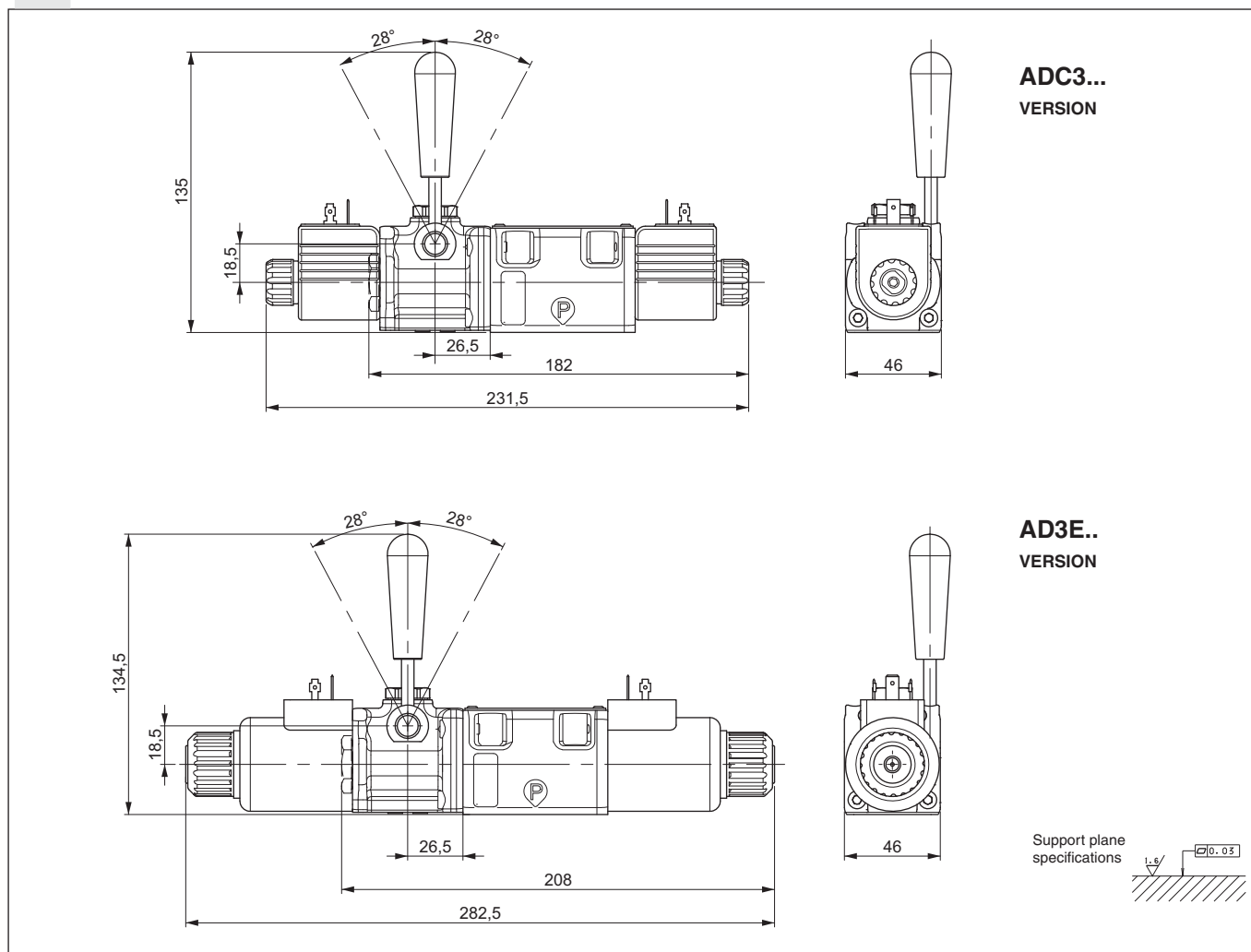

## PROXIMITY SENSOR TYPE LVDT

Supply voltage	24 V $\pm$ 20%
Polarity reversal protection	max 300 V
Switching point hysteresis	$\leq$ 0,06 mm
Reproducibility	$\pm$ 0,02 mm
Max. output current	$\leq$ 250 mA
Protection against short circuit	yes
Operating temperature	-25°C $\div$ 85°C
Connection type	connector
Protection according to DIN	IP65
Max. pressure	315 bar

CE certificate according to 89/336/EEC EMC is provided. A screened cable is needed.

The LVDT position transducers allow to check exactly the very instant when the passage of a minimum flow is allowed.

### FUNCTIONAL DIAGRAM ON PIN 2 AND 4

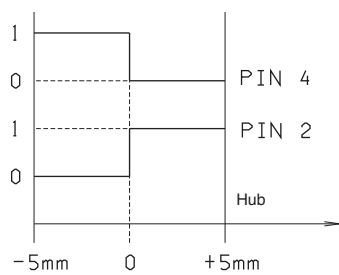

0 = Voltage Pin 2 and Pin 4 < 1,8 V  
1 = Voltage Pin 2 and Pin 4 24 V  $\pm$  20%

### OVERALL DIMENSION LVDT

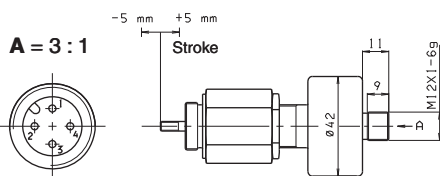

### OVERALL DIMENSIONS CONNECTOR

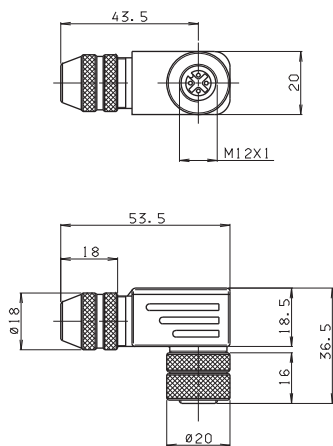

Type of protection IP67  
Ambient temperature -40°C  $\div$  85°C

Ordering code: V86400003

### ELECTRICAL CONNECTIONS LVDT

**A** With this connection, on the Pin 4 an output signal is active when no oil is crossing the valve (from P  $\rightarrow$  B).

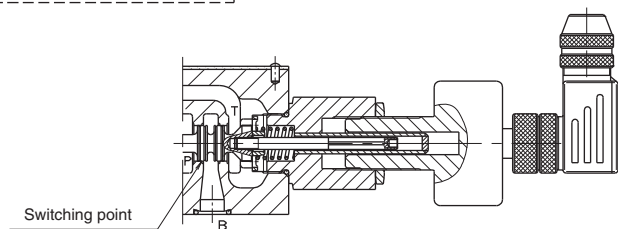
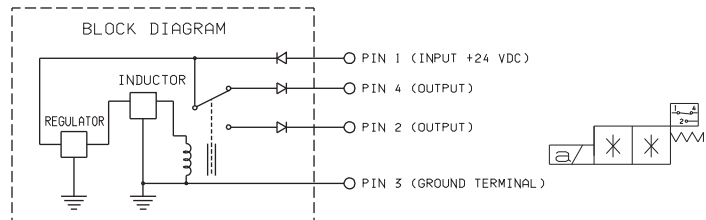

**B** With this connection, on the Pin 4 there is no output signal when oil is crossing the valve (from P  $\rightarrow$  B).

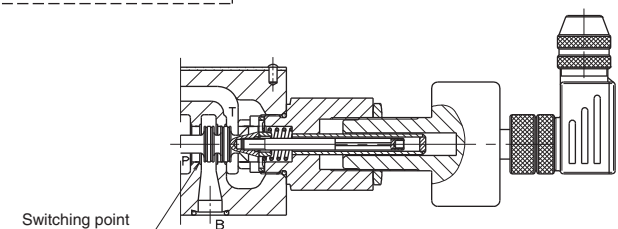
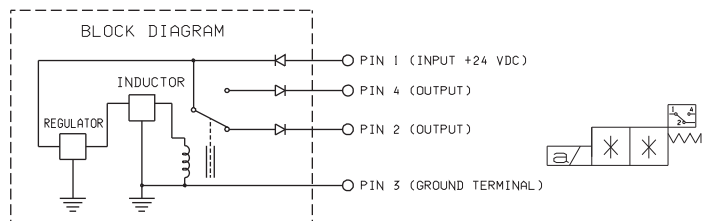

**NB:** connecting the output to Pin 4 or Pin 2 the type of contact, normally closed or open, can be chosen.



# DIRECTIONAL CONTROLE CETOP 3

## IN ACCORDANCE WITH 2014/34/UE ATEX DIRECTIVE

### 2014/34/UE ATEX EC DIRECTIVE (EXPLOSIVE ATMOSPHERE)

#### INTRODUCTION

Since 30/06/2003 products introduced into the market (or started-up) inside the EU, destined to be used in potentially explosive environments, must be in compliance with the 2014/34/UE Directive through special marking. The directive regarding ATEX products 2014/34/UE is therefore the regulation instrument that the European Union uses to obtain legislative harmonisation between the States and guarantee free circulation of goods inside the European Community itself.

The directive affirms that to eliminate obstacles from commerce it is necessary to guarantee a high level of protection and, with this aim, define the essential requirements on the subject of safety and health. The dispositions base themselves on the principle of the "new approach" (NA), for which the essential safety requirements of products must be established depending on the risk evaluation concurrent at the time of their use.

**The 2014/34/UE Directive is applied to the manufacture specifications** of all those products (electrical and not) destined to be used in potentially explosive environments caused, by the dangers deriving from the presence of dust or gas, with the scope of reducing the risk of use that could be derived.

The term **product** refers to appliances, protection systems, devices, components and relative combinations, as defined in 2014/34/UE Directive.

The term **appliances** intends machines, materials, fixed or mobile devices, control elements, instruments detection and prevention systems. Alone or combined these are destined for production, transport, deposit, measurement, adjustment and conversion of energy, and to the transformation of material and which, by way of the powerful triggering sources, risk causing an explosion. As a consequence, even intrinsically safe appliances re-enter within the field of application of the directive.

The combination of two or more appliance parts, as well as any other components, makes up a whole unit that can be considered a product and therefore re-enters within the field of application of the 2014/34/UE Directive. If the whole unit requires adequate **installation** (therefore it is not immediately ready for use) the attached instructions should guarantee maintenance of compliance to the 2014/34/UE Directive on installation, without further evaluations of conformity. The installer must follow the instructions correctly.

When a combination of appliances leads to a **plant** this may not re-enter within the field of application of the directive. Each part must be certified and in compliance with the directive (as well as being subject to the relative evaluation of conformity, EC marking, etc.).

The plant manufacturer must therefore presume the conformity of the various components (each supplied with conformity certificate released by the respective manufacturer) and limit their evaluation only to any additional risks that become important in the final combination. Nevertheless, if the plant manufacturer inserts parts without EC marking or components not supplied with the certificate it will be obligatory to carry out further conformity evaluation of the whole unit.

The 2014/34/UE Directive envisions **obligations of the person** who introduces products into the market and/or starts them up, whether they are manufacturer's, his agent's, importer's or any other responsible person. The dispositions and obligations envisioned by the directive for **introduction into the market** have been applied, since 30 June 2003, to every individual product, independently from the date and place of manufacture. It is the manufacturers responsibility to guarantee conformity of all products, where these re-enter within the field of application of the directive.

The directive does not govern the use of the appliances; rather it establishes that the products can only be used if in compliance with safety requirements at the time of their introduction into the market or of their start-up. "**Start-up**" means the first use of the products subject of the 2014/34/UE Directive on EU territory by a final user. Nevertheless, a product that is immediately ready for use and does not need assembly or installation, and whose distribution conditions (deposit, transport, etc.) are not important for performance, is considered started-up at the time of introduction into the market.

Among the main potential causes/sources of triggering an explosion, such as sparks, flames, electric arcs etc., **maximum surface temperature** also plays an important role. The dispositions of the directive establish evaluation criteria for the maximum temperature admissible depending on the type of explosive atmosphere in which the appliance must operate.

For environments characterised by the presence of **gas-air**, some temperature values are supplied to which the appliances must refer. They are indicated by the letter T followed by a number. The criterion to apply is that for which the temperature of the appliance must never exceed 80% of the value indicated for its own category.

For environments characterised by the presence of **dust-air**, to prevent setting on fire of the airborne dust, the surface temperature of the appliances must be decidedly lower than the predictable temperature of catching fire of the air+dust mixture. Therefore, during planning the maximum working surface temperature must be declared directly (in degrees centigrade).

Increases in temperature deriving from an accumulation of heat and chemical reactions must also be taken into consideration. The thickness of the deposited layer of dust must also be considered and, if necessary, limit the temperature, to prevent an accumulation of heat.

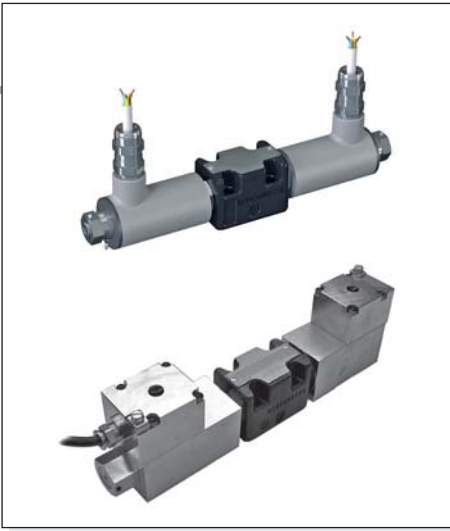

ATEX DIRECTIVE	CAP. I • 23
ATEX CLASSIFICATION	CAP. I • 24
SERIES AD3XD...	CAP. I • 25
SERIES AD3XG...	CAP. I • 29

1

### CLASSIFICATIONS OF AREA - MIX - GROUP AND RELATIVE CATEGORY – ACCORDING TO ATEX DIRECTIVES

1

The 2014/34/UE Directive is a “new approach” directive based on risk analysis. Its objective is to minimise the risks deriving from the use of some products indoors or in relation to a potentially explosive atmosphere. The probability of an explosive atmosphere manifesting must be considered not only as “one-off” or from a static point of view: all operative conditions that can derive from the transformation process must be taken into consideration.

- An **explosive atmosphere** for the 2014/34/UE Directive is made up from a mixture of inflammable substances (as gas, vapours, mists and dust), with air, in determined atmospheric conditions in which, after triggering, the combustion propagates together with the unburned mixture.

- An atmosphere susceptible to transforming into an explosive atmosphere because of local and/or operative conditions is defined **potentially explosive atmosphere**.

Explosive atmospheres are not only formed in the presence of obviously dangerous substances such as fuel, solvents etc., but also in the presence of apparently harmless products such as wood dust, metal dusts, flour, grain, sugar etc. Therefore it can concern not only industries in the chemical or oil industry sectors, but also industries in the foodstuffs, textile, manufacturing etc.. It is important to consider that to re-enter within the 2014/34/UE Directive a product must be applied in presence of one or more of the characteristic elements listed above: *presence of inflammable substances and air, in atmospheric conditions that favour the propagation of combustion*. The directive does not define the atmospheric conditions itself. The relative norms indicate a temperature range, but this does not exclude that the products may be planned and evaluated specifically to occasionally function outside of this range, introducing the opportune construction transformations.

To define a **conformity evaluation procedure** adequate for the directive, the Manufacturer must, on the basis of the declared use, establish the products functioning conditions (this means to say, envision the type of working area, the type of explosive mixture with which it will come into contact and the level of probability that an explosive atmosphere verifies itself); successively he must establish to which Group the product belongs and individualise the category inside the Group.

With the Atex 99/92/EC Directive (For the safety of workers) the working conditions in which products in compliance with Atex 99/92/EC Directive will function are indicated here. These are expressed in “**Areas**” and defined according to the level of probability that a potentially explosive atmosphere is verified, respectively for every type of atmosphere (gas-air mix or dust-air mix).

**Area 0 and 20** Places in which an explosive atmosphere is constantly present or present for long periods or frequently.

**Area 1 and 21** Places in which an explosive atmosphere is probable. It is verified in normal functioning and exercise conditions.

**Area 2 and 22** Places in which an explosive atmosphere has low probability of being verified or, if it occurs only lasts for a brief period of time.

#### **GAS-AIR-TYPE EXPLOSIVE MIXTURE (G)**

The products destined to work in environments characterised by this type of explosive atmosphere will be respectively indicated for Area **0, 1 or 2** depending on the Group and category of origin (see below) and are marked with the letter G.

#### **DUST-AIR-TYPE EXPLOSIVE MIXTURE (D)**

The products destined to work in environments characterised by this type of explosive atmosphere will be respectively indicated for Area **20, 21 or 22** depending on the Group and category of origin (see below) and are marked with the letter D.

#### **GROUP I**

*Includes the appliances destined to be used in underground jobs in the mines and their surface plants, exposed to the risk of the release of firedamp and/or combustible dust.* The subdivision into categories depends on the fact if the power supply must be interrupted or not if an explosive atmosphere manifests due to a mixture of air and gas, vapours mists (D) or a mixture of air and dust (G).

Category **M1 Very high protection level**. These products must be able to remain operative, for safety reasons, in the presence of an explosive atmosphere and present specific performances or protection configurations for breakdown in case of explosion.

Category **M2 High protection level**. The power supply to these products must be interrupted in the presence of an explosive atmosphere. Protection means must be incorporated to guarantee the level of protection during normal functioning and also in oppressive working conditions or resulting from great stress.

#### **GROUP II**

*Includes appliances destined to be used in different environments (from the mines) in which there is a probability that an explosive atmosphere manifests itself.* Their subdivision into categories depends on two factors: the place, where the product will be used and if the probability that a potentially explosive atmosphere, owing to the mixture of air and gas, vapours, mists (D) and the mixture of air and dust (G), comes about in a constant or occasional manner and if it does occur, does this possibility remain for long or brief period of time.

**Category 1 Very high protection level**. These products must be planned to function in compliance with operative parameters established by the Manufacturer in environments in which there is a high probability that explosive atmospheres are always detected or manifest often or for long periods of time. They must present specific performances or protection configurations for breakdown in case of explosion.

**Category 2 High protection level**. These products must be planned to function in compliance with operative parameters established by the Manufacturer in environments in which there is a high probability that explosive atmospheres can manifest. Protection against explosions relative to this category must function in a way to guarantee the required safety level even in the presence of functioning defects of the appliances or in dangerous operative conditions, which frequently must be taken into consideration.

**Category 3 Normal protection level**. These products must be planned to function in compliance with operative parameters established by the Manufacturer in environments in which there is a slight probability that explosive atmospheres can manifest, and however only rarely or for a brief period of time. This type of product belonging to the category in question must guarantee the safety level required in normal functioning conditions.

# AD3XD... DIRECTIONAL CONTROLE CETOP 3 IN ACCORDANCE WITH 2014/34/UE ATEX DIRECTIVE

1

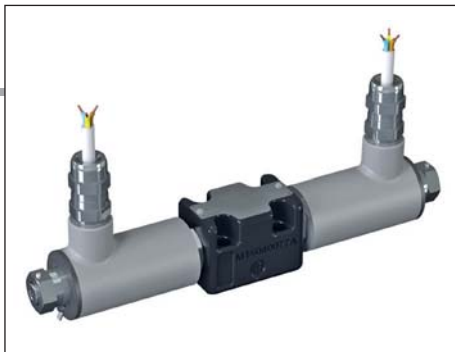

**SOLENOID VALVES FOR USE IN WORKPLACES WHERE EXPLOSIVE ATMOSPHERES MAY OCCUR DUE TO THE PRESENCE OF GAS, VAPOUR OR MIST AND DUST.**

AD3.XD solenoid valves are classified in:

**Group II** appliances (to be used in workplaces, apart from mines, where there is the probability of explosive atmospheres);

**Category 2** (high protection level), for use in workplaces where it is probable that an explosive atmosphere may form in normal working conditions and classified by the presence of explosive mixtures of gas-dust type (letter **GD**) for zones **1, 2** and **21, 22**.

**Group I** (They are intended to be used in mines with gas firedamp);

**Category M2** (high level of protection), they are intended for use in underground environment in mines and their surface installations, exposed to the likely risk of the release of firedamp and / or combustible dust under normal operating conditions.

These valves are therefore designed especially and manufactured in compliance with the ATEX 2014/34/UE Directive and according to European regulations EN 1127-1, EN 1127-2, EN 13463-1 and EN 13463-5.

Belonging to the "NG06 direction control" range, these valves are prepared for plate-mounting with attachment surface in compliance with UNI ISO 4401 - 03 - 02 - 0 - 94 (former CETOP R 35 H 4.2-4-03). They are activated electrically and the centre position is ensured by springs with gauged lengths, which once the pulse or command ceases, re-position the spool in the centre or at the end of travel position.

The coils used for these valves are subject to separate conformity certification, according to the ATEX Directive (EC-type). For further specifications, please consult the documents that are always supplied with the valve.

Before marking and marketing the valves of the AD3XD series, undergo tests and inspections according to the in-house Manufacturing System and to the Certified Company Quality System in compliance with ISO 9001:2008. All of the AD3XD valve series undergo 100% functional testing. These tests and inspections guarantee that the products sold comply with all the information reported in the Technical Specifications File registered and declared by marking with AD3X/ATEX/10.

AD3XD...	
ATEX DIRECTIVE	CAP. I • 23
ATEX CLASSIFICATION	CAP. I • 24
SERIES AD3XD...	CAP. I • 25
TECHNICAL SPECIFICATIONS	CAP. I • 25
ORDERING CODE	CAP. I • 25
TAB.1 ASSEMBLY	CAP. I • 26
TAB.2 VOLTAGES	CAP. I • 26
TAB.3 SPOOL	CAP. I • 26
LIMITS OF USE	CAP. I • 26
IDENTIFICATION NAMEPLATE	CAP. I • 27
SAFETY INSTRUCTIONS	CAP. I • 27
OVERALL DIMENSIONS	CAP. I • 28

## ORDERING CODE

<b>AD</b>	Directional Control Valve
<b>3</b>	CETOP 3/NG06
<b>XD</b>	Solenoid valves built pursuant to ATEX Directive-2014/34/UE. With coils in explosion-proof version (Ex d) and IECEx conformity marked
<b>**</b>	Spools <b>01/02/03/04/16</b> (tab.3). For further hydraulic diagrams, contact our Customer Service
<b>*</b>	Assembly <b>C / E / F / G / H</b> (tab.1). For further assembly instructions, contact our Customer Service
<b>*</b>	Voltage (tab.2)
<b>**</b>	Variants <b>00</b> = None <b>V1</b> = Viton <b>LE</b> = Emergency lever <b>T6</b> = Suitable for temperature class I M2 Group T6 (<85°C) (mine)
<b>2</b>	Serial number

## TECHNICAL SPECIFICATIONS

Description	AD3XD...	T6 version (mine)
<b>Valve marking</b>	<b>CE Ex II 2GD/I M2 cT5</b>	<b>CE Ex II 2GD/I M2 cT6</b>
Max. pressure on lines P/A/B	320 bar	320 bar
Max. pressure on line T (dynamic)	250 bar	250 bar
Max. flow rate	60 l/min	60 l/min
Max. excitation frequency	3 Hz	3 Hz
Duty cycle	100%ED	100%ED
Hydraulic fluids	mineral oils DIN 51524	mineral oils DIN 51524
Fluid viscosity	10 ÷ 500 mm <sup>2</sup> /s	10 ÷ 500 mm <sup>2</sup> /s
<b>Fluid temperature (*)</b>	<b>-20°C ÷ +40°C</b>	<b>-20°C ÷ +40°C</b>
<b>Ambient temperature</b>	<b>-20°C ÷ +40°C</b>	<b>-20°C ÷ +40°C</b>
Max. contamination level	NAS 1638: class 10 with filter β <sub>25</sub> ≥ 75	NAS 1638: class 10 with filter β <sub>25</sub> ≥ 75
Weight (one solenoid)	2,37 kg	2,37 kg
Weight (two solenoids)	3,82 kg	3,82 kg
Solenoid rated power:	6,5 ÷ 11W	
Degree of protection:	IP 67	
Power supply tolerance:	±10%	
Power supply cable:	standard length 3 m with cable gland	
Solenoid marking (**):	consult documents supplied with solenoid	
Surface temperature:	function of the power. Consult documents supplied with solenoid.	

(\*) For use with different hydraulic fluids, which do not constitute an effective ignition source in potentially explosive atmospheres IIC across the range of temperatures and pressures required by the unit marking, contact our technical department.

(\*\*) Solenoid is provided with marking for protection class according to Explosion Protection Directive ATEX-2014/34/UE and IECEx certificate of conformity mark.

# AD3XD... DIRECTIONAL CONTROLE CETOP 3

## IN ACCORDANCE WITH 2014/34/UE ATEX DIRECTIVE

1

**TAB.1 ASSEMBLY**

STANDARD	
<b>C</b>	Two solenoids centred
<b>E</b>	One solenoid (side A)
<b>F</b>	One solenoid (side B)
<b>Specials (with increased price)</b>	
<b>G</b>	
<b>H</b>	

**TAB.2 VOLTAGES**

AC Voltage	
<b>A</b>	24V 50Hz/60Hz
<b>C</b>	110V 50Hz/60Hz
<b>D</b>	220V 50Hz/60Hz
<b>I</b>	230V 50Hz/60Hz
DC Voltage	
<b>L</b>	12V
<b>M</b>	24V
<b>P</b>	110V
<b>N</b>	48V

The tension symbol is always printed on the nameplate.

**TAB.3 SPOOL**

Two solenoids - Assembly C			
Spool type	Covering	Transient position	
<b>01</b>	+		
<b>02</b>	-		
<b>03</b>	+		
<b>04*</b>	-		

One solenoid - Assembly E			
Spool type	Covering	Transient position	
<b>01</b>	+		
<b>02</b>	-		
<b>03</b>	+		
<b>04*</b>	-		
<b>16</b>	+		

One solenoid - Assembly F			
Spool type	Covering	Transient position	
<b>01</b>	+		
<b>02</b>	-		
<b>03</b>	+		
<b>04*</b>	-		
<b>16</b>	+		

(\*) spool with increased price

**LIMITS OF USE (MOUNTING C-E-F)**

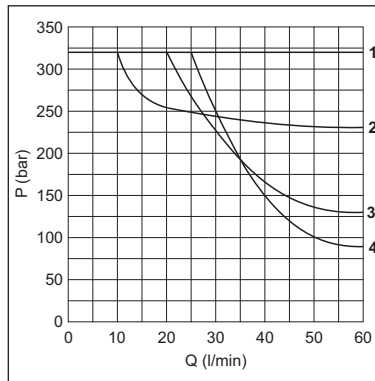

**NOTE:** the operating limits shown are valid for C fittings, E, F.

Spool type	Curve
01	2
02	1
03	3
04	4
16	1

The tests have been carried out with solenoids at operating temperature with a voltage 10% less than rated voltage with a fluid temperature of 40°C. The fluid used was a mineral oil with a viscosity of 46 mm<sup>2</sup>/s at 40°C. The values in the diagram refers to tests carried out with the oil flow in two direction simultaneously (e.g.. from P to A and in the same time B to T).

**In cases where valves 4/2 e 4/3 were used with the flow in one direction only, the limits of use could have variations which may even be negative.**

**PRESSURE DROPS**

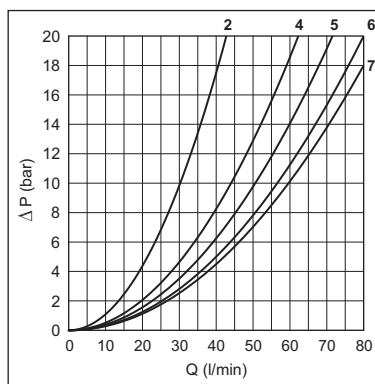

The diagram at the side shows the pressure drop curves for spools during normal usage. The fluid used is a mineral oil with a viscosity of 46 mm<sup>2</sup>/s at 40°C; the tests have been carried out at a fluid temperature of 40°C. For higher flow rates than those in the diagram, the losses will be those expressed by the following formula:

$$\Delta p_1 = \Delta p \times (Q_1/Q)^2$$

where  $\Delta p$  will be the value for the losses for a specific flow rate  $Q$  which can be obtained from the diagram,  $\Delta p_1$  will be the value of the losses for the flow rate  $Q_1$  that is used.

Spool type	Connections				
	P→A	P→B	A→T	B→T	P→T
01	5	5	5	5	
02	7	7	7	7	6
03	5	5	6	6	
04	2	2	2	2	4
16	5	5	4	4	

Curve No.

# AD3XD... DIRECTIONAL CONTROLE CETOP 3

## IN ACCORDANCE WITH 2014/34/UE ATEX DIRECTIVE

### IDENTIFICATION NAMEPLATE AND MARKING

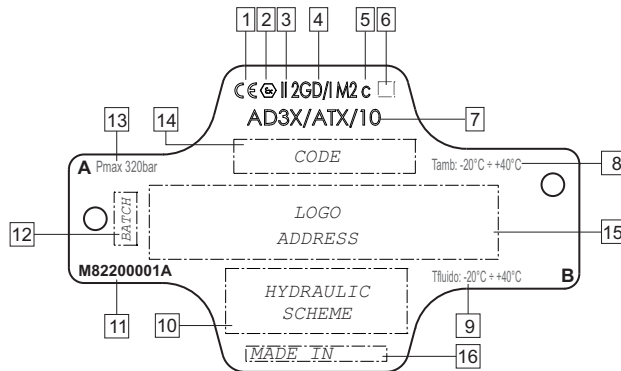

All the solenoid valves are supplied with **identification nameplate and Declaration of conformity** subject to Directive 2014/34/UE.

The identification nameplate bears the main technical specifications related to the functional and constructional characteristics of the valve and **must therefore be kept intact and visible**.

1	CE	Conformity to European Directive
2	Ex	Conformity to ATEX Directive 2014/34/UE
3	II 2 I	Group II (surface places) Group I (mine) Category 2 (high protection)
4	GD M	Explosive atmosphere: GD: presence of gas, vapour or mist and combustible dust M: presence of firedamp atmospheres
5	c	Constructional safety
6	T*	Temperature class: T5 (T <sub>sur</sub> < 100 °C) T6 (T <sub>sur</sub> < 85 °C) T6 version (mine)
7	AD3X/ ATX/10	Reference to Technical File registered c/o Notified Body
8	T amb	Working ambient temperature: - 20°C ÷ + 40°C series AD3XD

9	T fluid	Working fluid temperature: - 20°C ÷ + 40°C series AD3XD
10	HYDRAULIC SCHEME	Type of hydraulic control performed by the valve
11	M82200001A	Nameplate code
12	BATCH	Reference number of technical order (batch)
13	Pmax 320 bar	Max working pressure
14	CODE	Complete reference number of valve ordering code
15	LOGO ADDRESS	Logo and address
16	MADE IN	Preferential origin

### SAFETY INSTRUCTIONS

- Read the instruction handbook supplied with the valves carefully before installation. All maintenances must be carried out following the instructions given in the manual.
- The AD3XD series valves must be installed and serviced in compliance with plant engineering and maintenance regulations for workplaces classified against the risk of explosion due to the presence of gas and dust and gas (for example: CEI EN 60079-14, CEI EN 60079-17, CEI EN 61241-14, CEI EN 61241-17 or other national regulations/standards).
- The valves must be connected to earth using the special anti-loosening and anti-rotation connection element.
- For all safety aspects related to the use of the coils, consult the relative use and maintenance instructions. The electrical appliances/components must not be opened when live.
- The user must periodically inspect, based on the conditions of use and the substances used, the presence of scale, dirt, the state of wear and tear and correct efficiency of the valves.

**Attention: all installation and maintenance jobs must be carried out by qualified personnel.**

# AD3XD... DIRECTIONAL CONTROLE CETOP 3

IN ACCORDANCE WITH 2014/34/UE ATEX DIRECTIVE

## OVERALL DIMENSIONS

1

AD3XD...

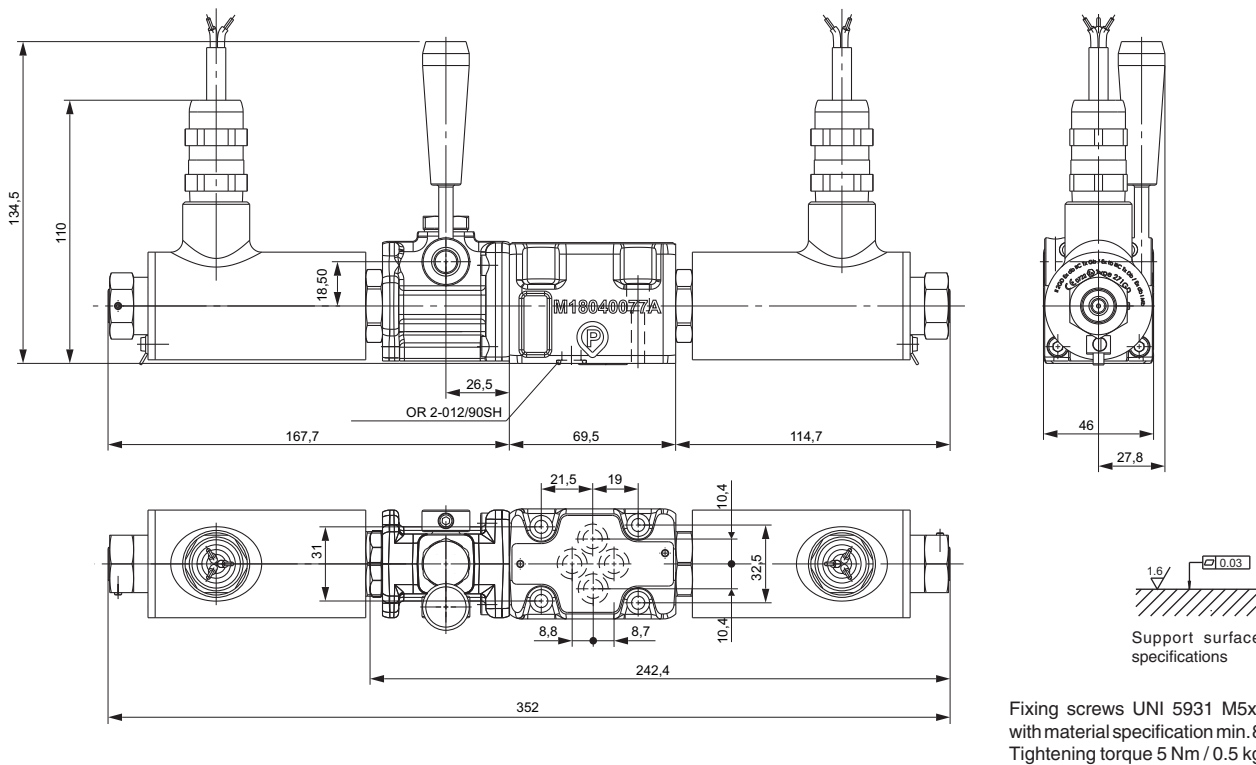
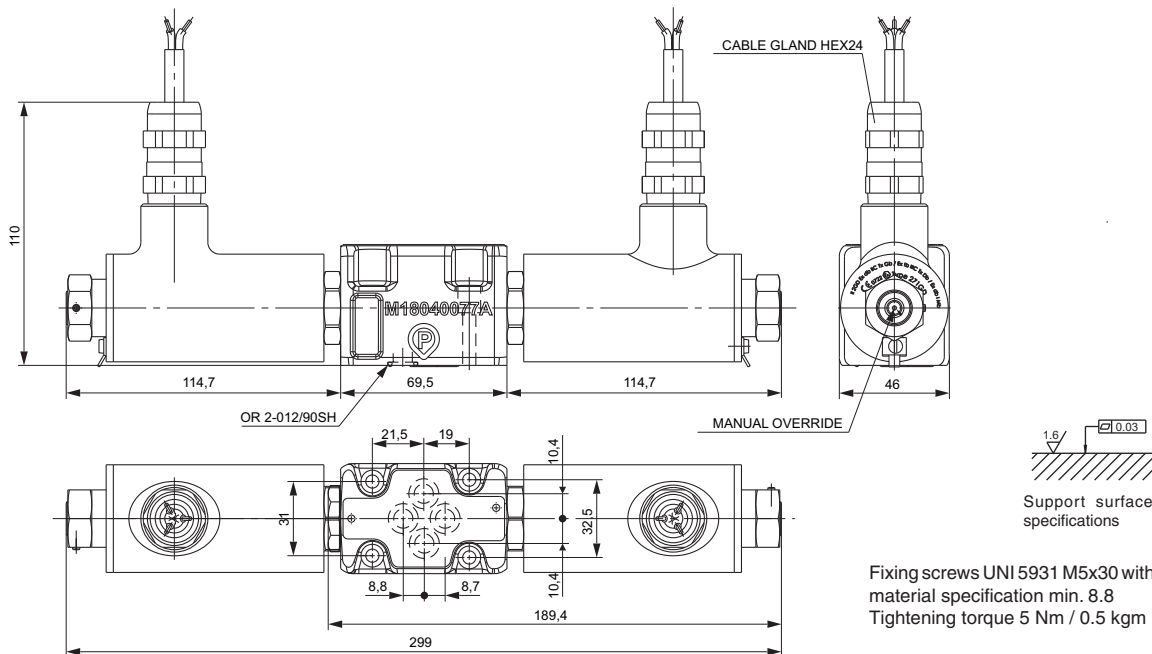

# AD3XG... DIRECTIONAL CONTROLE CETOP 3 IN ACCORDANCE WITH 2014/34/UE ATEX DIRECTIVE

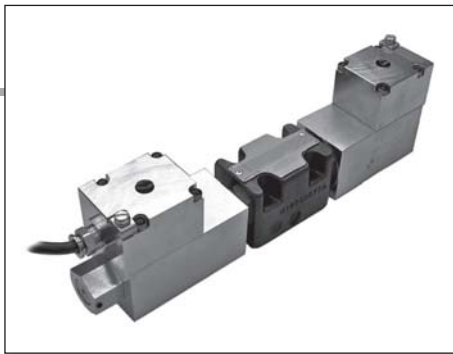

**SOLENOID VALVES FOR USE IN WORKPLACES WHERE EXPLOSIVE ATMOSPHERES  
MAY OCCUR DUE TO THE PRESENCE OF GAS, VAPOUR OR MIST AND DUST.**

1

AD3XG solenoid valves are classified in:

**Group II** appliances (to be used in workplaces, apart from mines, where there is the probability of explosive atmospheres);

**category 2** (high protection level), for use in workplaces where it is probable that an explosive atmosphere may form in normal working conditions and classified by the presence of explosive mixtures of gas-dust type (letter **GD**) for zones **1, 2** and **21, 22**.

These valves are therefore designed especially and manufactured in compliance with the ATEX 2014/34/UE Directive and according to European regulations EN 1127-1, EN 1127-2, EN 13463-1 and EN 13463-5.

Belonging to the "NG06 direction control" range, these valves are prepared for plate-mounting with attachment surface in compliance with UNI ISO 4401 - 03 - 02 - 0 - 94 (former CETOP R 35 H 4.2-4-03). They are activated electrically and the centre position is ensured by springs with gauged lengths, which once the pulse or command ceases, re-position the spool in the centre or at the end of travel position.

The coils used for these valves are subject to separate conformity certification, according to the ATEX Directive (EC-type). For further specifications, please consult the documents that are always supplied with the valve.

Before marking and marketing the valves of the AD3XG series, undergo tests and inspections according to the in-house Manufacturing System and to the Certified Company Quality System in compliance with ISO 9001:2008. All of the AD3XG valve series undergo 100% functional testing. These tests and inspections guarantee that the products sold comply with all the information reported in the Technical Specifications File registered and declared by marking with AD3X/ATEX/10.

AD3XG...	
ATEX DIRECTIVE	CAP. I • 23
ATEX CLASSIFICATION	CAP. I • 24
SERIES AD3XG...	CAP. I • 29
TECHNICAL SPECIFICATIONS	CAP. I • 29
ORDERING CODE	CAP. I • 29
TAB.1 ASSEMBLY	CAP. I • 30
TAB.2 VOLTAGES	CAP. I • 30
TAB.3 SPOOL	CAP. I • 30
LIMITS OF USE	CAP. I • 30
IDENTIFICATION NAMEPLATE	CAP. I • 31
SAFETY INSTRUCTIONS	CAP. I • 31
OVERALL DIMENSIONS	CAP. I • 32

## ORDERING CODE

<b>AD</b>	Directional Control Valve
<b>3</b>	CETOP 3/NG06
<b>XG</b>	Solenoid valves built pursuant to ATEX Directive-2014/34/UE. With coils in explosion-proof version (Ex d) and IECEx conformity marked.
<b>**</b>	Temperature Class <b>T4</b> (T <sub>sur</sub> < 135 °C) <b>T6</b> (T <sub>sur</sub> < 85 °C)
<b>**</b>	Spools <b>01/02/03/04/16</b> (tab.3). For further hydraulic diagrams, contact our Customer Service
<b>*</b>	Assembly <b>C / E / F / G / H</b> (tab.1). For further assembly instructions, contact our Customer Service
<b>*</b>	Voltage (tab.2)
<b>**</b>	Variants <b>00</b> = None <b>V1</b> = Viton <b>LE</b> = Emergency lever
<b>1</b>	Serial number

## TECHNICAL SPECIFICATIONS

Description	AD3XG T4...	AD3XG T6...
<b>Valve marking</b>	<b>CE Ex II 2 GD cT4</b>	<b>CE Ex II 2 GD cT6</b>
Max. pressure on lines P/A/B	350 bar	350 bar
Max. pressure on line T (dynamic)	250 bar	250 bar
Max. flow rate	80 l/min	80 l/min
Max. excitation frequency	3 Hz	3 Hz
Duty cycle	100%ED	100%ED
Hydraulic fluids	mineral oils DIN 51524	mineral oils DIN 51524
Fluid viscosity	10 ÷ 500 mm <sup>2</sup> /s	10 ÷ 500 mm <sup>2</sup> /s
<b>Fluid temperature (*)</b>	<b>-30°C ÷ +70°C</b>	<b>-30°C ÷ +70°C</b>
<b>Ambient temperature</b>	<b>-40°C ÷ +80°C</b>	<b>-40°C ÷ +50°C</b>
Max. contamination level (filter β <sub>25</sub> ≥ 75)	ISO 4406:1999: class 21/19/16 NAS 1638: class 10	ISO 4406:1999: class 21/19/16 NAS 1638: class 10
Weight (one solenoid)	3 kg	3 kg
Weight (two solenoids)	5 kg	5 kg
Coil rated power	8,5 W	8,5 W
Degree of protection	IP 67	IP 67
Power supply tolerance	±10%	±10%
Power supply cable	standard length 3m with cable gland	standard length 3m with cable gland
Coil marking (**):	consult documents supplied with coil	consult documents supplied with coil
Surface temperature	< 135°C	< 85°C

(\*) AD3XG valves have been certified for minimum fluid temperatures up to -30°C. Please contact our Technical department for applications at fluid temperatures < -25°C.



(\*\*) Coil is provided with marking for protection class according to Explosion Protection Directive ATEX-2014/34/UE and IECEx certificate of conformity mark.

# AD3XG... DIRECTIONAL CONTROLE CETOP 3

## IN ACCORDANCE WITH 2014/34/UE ATEX DIRECTIVE

1

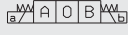
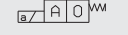
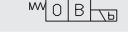
**TAB.1 ASSEMBLY**









STANDARD	
<b>C</b>	 Two solenoids centred
<b>E</b>	 One solenoid (side A)
<b>F</b>	 One solenoid (side B)
<b>Specials (with increased price)</b>	
<b>G</b>	
<b>H</b>	

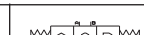
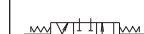

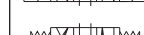

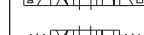

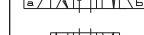
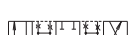

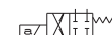

**TAB.2 VOLTAGES**











AC Voltage for AD3XG	
<b>A</b>	24V 50Hz/60Hz
<b>B</b>	48V 50Hz/60Hz
<b>C</b>	110V 50Hz/60Hz
<b>D</b>	220V 50Hz/60Hz
<b>I</b>	230V 50Hz/60Hz
DC Voltage for AD3XG	
<b>L</b>	12V
<b>M</b>	24V
<b>P</b>	110V
<b>N</b>	48V
<b>U</b>	36V
<b>6</b>	60V
<b>G</b>	125V

The tension symbol is always printed on the nameplate.

**TAB.3 SPOOL**

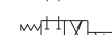
Two solenoids - Assembly C			
Spool type		Covering	Transient position
			
			
			
			
			

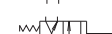
One solenoid - Assembly E			
Spool type		Covering	Transient position
			
			
			
			
			

One solenoid - Assembly F			
Spool type		Covering	Transient position
			
			
			
			
			

(\*) spool with increased price

**LIMITS OF USE (MOUNTING C-E-F)**

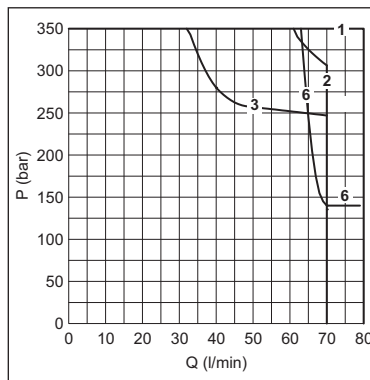

**NOTE:** The limit of use are valid for C, E, F assembly.

Spool type	Curve
01	1
02	1
03	3
04	2
16	6

The tests have been carried out with solenoids at operating temperature with a voltage 10% less than rated voltage with a fluid temperature of 40°C. The fluid used was a mineral oil with a viscosity of 46 mm<sup>2</sup>/s at 40°C. The values in the diagram refers to tests carried out with the oil flow in two direction simultaneously (e.g.. from P to A and in the same time B to T).

**In cases where valves 4/2 e 4/3 were used with the flow in one direction only, the limits of use could have variations which may even be negative.**

**PRESSURE DROPS**

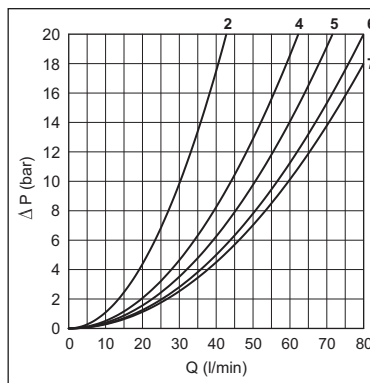

The diagram at the side shows the pressure drop curves for spools during normal usage. The fluid used is a mineral oil with a viscosity of 46 mm<sup>2</sup>/s at 40°C; the tests have been carried out at a fluid temperature of 40°C. For higher flow rates than those in the diagram, the losses will be those expressed by the following formula:

$$\Delta p_1 = \Delta p \times (Q_1/Q)^2$$

where  $\Delta p$  will be the value for the losses for a specific flow rate Q which can be obtained from the diagram,  $\Delta p_1$  will be the value of the losses for the flow rate Q1 that is used.

Spool type	Connections				
	P→A	P→B	A→T	B→T	P→T
01	5	5	5	5	
02	7	7	7	7	6
03	5	5	6	6	
04	2	2	2	2	4
16	5	5	4	4	

Curve No.



# AD3XG... DIRECTIONAL CONTROLE CETOP 3

## IN ACCORDANCE WITH 2014/34/UE ATEX DIRECTIVE

### IDENTIFICATION NAMEPLATE AND MARKING

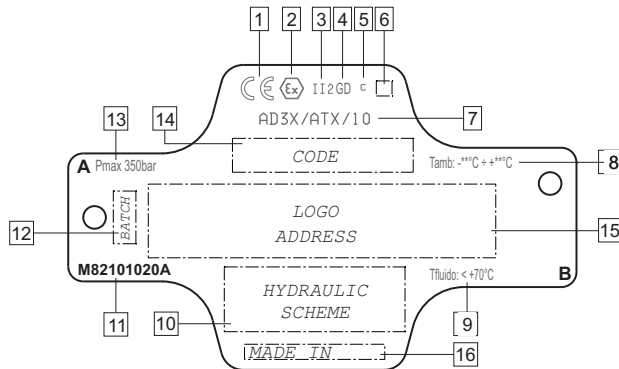

All the solenoid valves are supplied with **identification nameplate and Declaration of conformity** subject to Directive 2014/34/UE.

The identification nameplate bears the main technical specifications related to the functional and constructional characteristics of the valve and **must therefore be kept intact and visible**.

1	CE	Conformity to European Directive
2	Ex	Conformity to ATEX Directive 2014/34/UE
3	II 2	Group II (surface places) Category 2 (high protection)
4	GD	Explosive atmosphere: <b>GD</b> : presence of gas, vapour or mist and combustible dust
5	c	Constructional safety
6	T*	Temperature class: <b>T4</b> ( $T_{sur} < 135\text{ °C}$ ) series AD3XG T4 <b>T6</b> ( $T_{sur} < 85\text{ °C}$ ) series AD3XG T6
7	AD3X/ATX/10	Reference to Technical File registered c/o Notified Body
8	T amb	Working ambient temperature: - 40°C ÷ + 80°C series AD3XG T4 - 40°C ÷ + 50°C series AD3XG T6

9	T fluid	Working fluid temperature: - 30°C ÷ + 70°C series AD3XG
10	HYDRAULIC SCHEME	Type of hydraulic control performed by the valve
11	M82101020A	Nameplate code
12	BATCH	Reference number of technical order (batch)
13	Pmax 350 bar	Max. working pressure
14	CODE	Complete reference number of valve ordering code
15	LOGO ADDRESS	Logo and address
16	MADE IN	Preferential origin

### SAFETY INSTRUCTIONS

- Read the instruction handbook supplied with the valves carefully before installation. All maintenances must be carried out following the instructions given in the manual.
- The AD3XG series valves must be installed and serviced in compliance with plant engineering and maintenance regulations for workplaces classified against the risk of explosion due to the presence of gas and dust and gas (for example: CEI EN 60079-14, CEI EN 60079-17, CEI EN 61241-14, CEI EN 61241-17 or other national regulations/standards).
- The valves must be connected to earth using the special anti-loosening and anti-rotation connection element.
- For all safety aspects related to the use of the coils, consult the relative use and maintenance instructions. The electrical appliances/components must not be opened when live.
- The user must periodically inspect, based on the conditions of use and the substances used, the presence of scale, dirt, the state of wear and tear and correct efficiency of the valves.

**Attention: all installation and maintenance jobs must be carried out by qualified personnel.**

# AD3XG... DIRECTIONAL CONTROLE CETOP 3

## IN ACCORDANCE WITH 2014/34/UE ATEX DIRECTIVE

### OVERALL DIMENSIONS

1

#### AD3XG...

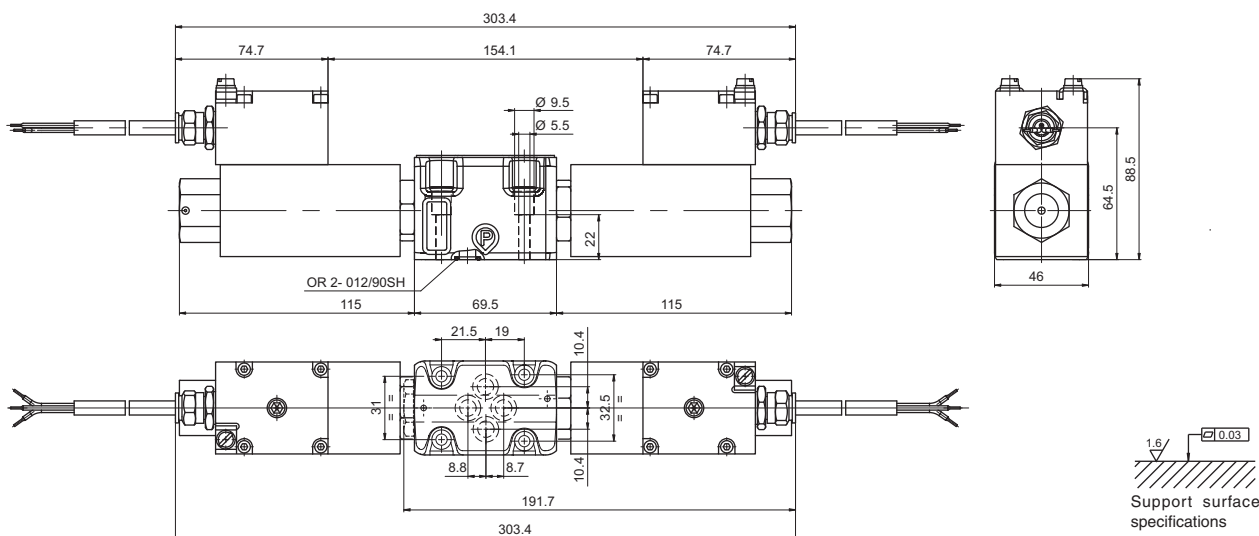

Fixing screws UNI 5931 M5x30  
with material specification min. 8.8  
Tightening torque 5 Nm / 0.5 kgm

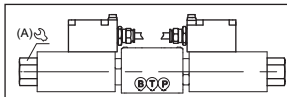

Should it be necessary to change the coils position, fastener ring nut A as described in the solenoid valve assembly instructions.

#### AD3XG...LE.

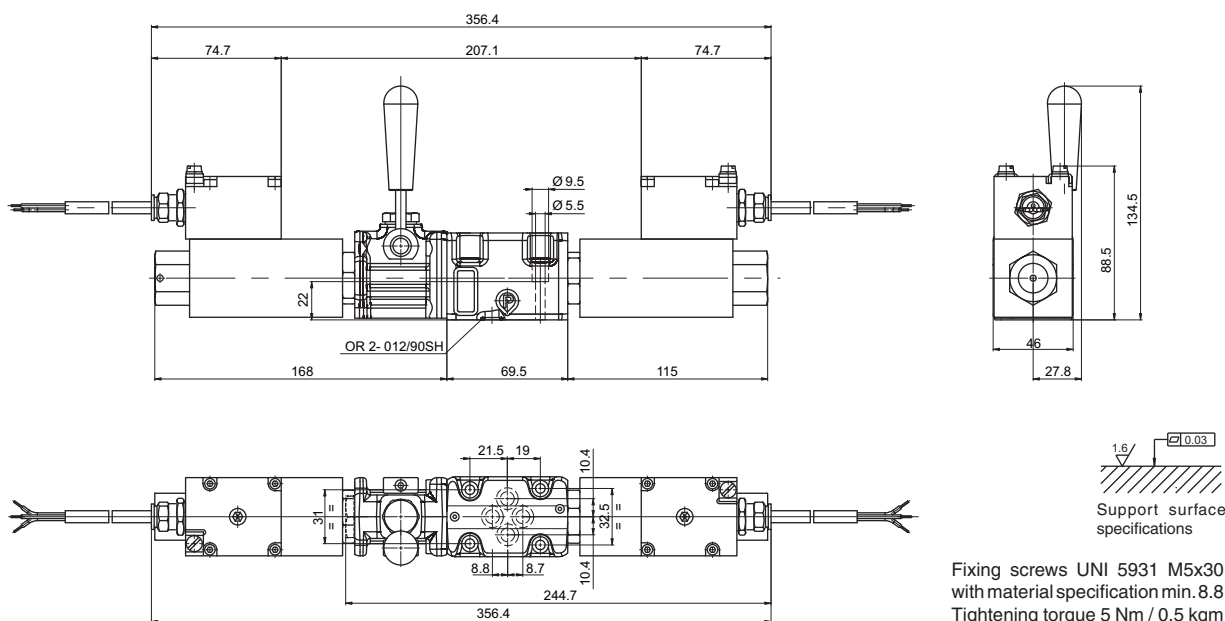

Fixing screws UNI 5931 M5x30  
with material specification min. 8.8  
Tightening torque 5 Nm / 0.5 kgm

# DIRECTIONAL CONTROL VALVES CETOP 5

1



## CETOP 5/NG10

STANDARD SPOOLS	CAP. I • 35
AD5E...	CAP. I • 36
AD5E...J*	CAP. I • 37
AD5E...Q5	CAP. I • 37
AD5O...	CAP. I • 38
AD5D...	CAP. I • 38
AD5L...	CAP. I • 39
"A16" DC SOLENOIDS	CAP. I • 40
"K16" AC SOLENOIDS	CAP. I • 40
STANDARD CONNECTORS	CAP. I • 20

## INTRODUCTION

The directional control valves NG10 designed for subplate mounting with an interface in accordance with UNI ISO 4401 - 05 - 04 - 0 - 94 standard (ex CETOP R 35 H 4.2-4-05), and can be used in all fields on account of their excellent capacity and pressure specifications.

The use of solenoids with wet armatures means that the construction is extremely functional and safe completely dispensing with need for dynamic seals. The solenoid dust cover is screwed directly onto the valve casing whilst the coil is kept in position by a ring nut.

Great care has been taken in the design and the production of the ducts and the improvement of the spools has allowed relatively high flow rates to be accommodated with minimal pressure drops ( $\Delta p$ ). The operation of the directional valves can be electrical, pneumatic, oleodynamic, mechanical or lever operated.

The centring position is achieved by means of calibrated length springs which, once the action of impulse is over, return the spool to the centre or end travel position.

The solenoids constructed with protection class in accordance with DIN 40050 standards are available in either direct current (IP65) or alternating current (IP66) with different voltage and frequencies.

All types of electrical controls can be fitted, on request, with different types of manual emergency controls. The electrical supply takes place through connectors meeting DIN 43650 ISO 4400 standards; connectors are also available with built in rectifier or pilot lights.

The valves are designed for use with DIN 51524 standard hydraulic mineral oils and it is recommended that filters should be fitted to ensure a maximum contamination level of class 10 in accordance with NAS 1638,  $\beta_{25} \geq 75$ .

## PRESSURE DROPS

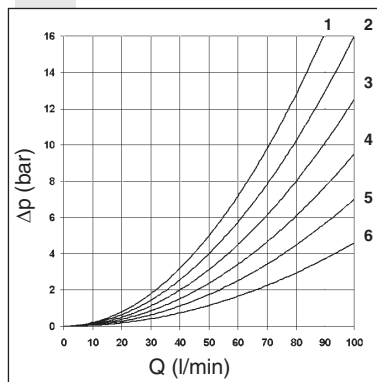

The diagram at the side show the pressure drop curves for spools during normal usage. The fluid used is a mineral oil with a viscosity of 46 mm<sup>2</sup>/s at 40°C; the tests have been carried out at a fluid temperature of 40°C.

For higher flow rates than those in the diagram, the losses will be those expressed by the following formula:

$$\Delta p1 = \Delta p \times (Q1/Q)^2$$

where  $\Delta p$  will be the value for the losses for a specific flow rate Q which can be obtained from the diagram,  $\Delta p1$  will be the value of the losses for the flow rate Q1 that is used.

Spool type	Connections				
	P→A	P→B	A→T	B→T	P→T
01	2	2	5	5	
02	3	3	6	6	3
03	2	2	6	6	
04	3	3	4	4	1
05	3	3	5	5	
06	2	2	5	5	
66	2	2	5	5	
07		1	5		
10	3	3	5	5	
11	4			5	
	Curve No.				

Spool type	Connections				
	P→A	P→B	A→T	B→T	P→T
22		4	5		
14	3	3	6	6	2
15	2	2	4	5	
16	2	2	4	5	
17	3	3			
19	3	3	4	5	
20	3	3	4	5	
21	3	3			
28	3	3	6	6	2
	Curve No.				

# DIRECTIONAL CONTROL VALVES CETOP 5

1

## ORDERING CODE

<b>AD</b>	Directional valve
<b>5</b>	CETOP 5/NG10
*	Type of operator (tab.1)
**	Spools (see tables Cap. I • 35)
*	Mounting type (tab. 2)
*	Voltage / Specification (tab. 3)
**	Variants (tab. 4)
<b>2</b>	Serial No.

## TAB.1 - TYPE OF OPERATOR

<b>E</b>	Electrical
<b>D</b>	Direct mechanical
<b>O</b>	Oleo-pneumatic
<b>L</b>	Lever

## TAB.2 - MOUNTING

STANDARD	
<b>C</b>	
<b>D</b>	
<b>E</b>	
<b>F</b>	
SPECIALS (WITH PRICE INCREASING)	
<b>G</b>	
<b>H</b>	
<b>I</b>	
<b>L</b>	
<b>M</b>	

• **Mounting type D** is only for valves with detent

• In case of **mounting D** with detent a maximum supply time of 2 sec is needed (only for AC coils).

• The springs for the version with detent (mounting **D**) are different from those for standard versions.

## TAB.3 - VOLTAGE / SPECIFICATION

Operator	Voltage Specs.	Description	Note
<b>E</b>	<b>A</b>	24V/50Hz	AC Voltage ** (Technical data see page I • 40)
	<b>B</b>	48V/50Hz*	
	<b>J</b>	115V/50Hz - 120V/60Hz	
	<b>Y</b>	230V/50Hz - 240V/60Hz	
	<b>E</b>	240V/50Hz*	
	<b>F</b>	24V/60Hz*	
	<b>K</b>	Without AC coils	DC Voltage ** (Technical data see page I • 40)
	<b>L</b>	12V	
	<b>M</b>	24V	
	<b>N</b>	48V*	
	<b>P</b>	110V*	
	<b>Z</b>	102V* 115Vac/50Hz 120Vac/60Hz with rectifier	
	<b>X</b>	205V* 230Vac/50Hz 240Vac/60Hz with rectifier	
<b>W</b>	Without DC coils		
<b>D</b>	<b>Z</b>	standard	—
<b>O</b>	<b>Z</b>	standard	—
<b>L</b>	<b>Z</b>	valve with lever	—
	<b>X</b>	valve without lever	—

\* Special voltage

\*\* Voltage codes are not stamped on the plate, their are readable on the coils.

## TAB.4 - VARIANTS

VARIANT	CODE	◆	PAGE
No variant (without connectors)	S1(*)		
Viton	SV(*)		
Emergency button	ES(*)		Cap. I • 40
Preset for microswitch - (E/F/G/H only) see below note ◊	MS(*)	◆	Cap. I • 36 - Cap. I • 39
Rotary emergency button	P2(*)		Cap. I • 40
Marine version (AD.5.O..)	H1	◆	
Preset for microswitch + Viton	MV	◆	
Spool movement speed control (VDC only) with ø 0.5 mm diameter orifice	5S(*)	◆	Cap. I • 37
Spool movement speed control (VDC only) with ø 0.6 mm diameter orifice	6S(*)	◆	Cap. I • 37
Spool movement speed control (VDC only) with ø 0.7 mm diameter orifice	7S(*)	◆	Cap. I • 37
Spool movement speed control (VDC only) with ø 0.8 mm diameter orifice	8S(*)	◆	Cap. I • 37
External draining solenoid (electrically operated only)	S5(*)	◆	Cap. I • 37
Microswitch+ Detent (for lever operation)	MD	◆	
Detent for lever control	D1	◆	

◊ = Maximum counter-pressure on T port: 4 bar - Microswitch type AM1107 code V79000001 can be ordered separately.  
◆ = Variant codes stamped on the plate

(\*) Coils with Hirschmann connection supplied without connectors. The connectors can be ordered separately, Cap. I • 20.

# DIRECTIONAL CONTROL VALVES CETOP 5

1

TWO SOLENOIDS, SPRING CENTRED "C" MOUNTING			
Spool type		Covering	Transient position
01		+	
02		-	
03		+	
04*		-	
05		+	
66		+	
06		+	
07*		+	
08*		+	
10*		+	
22*		+	
11*		+	
12*		+	
13*		+	
14*		-	
28*		-	

ONE SOLENOID, SIDE A "E" MOUNTING			
Spool type		Covering	Transient position
01		+	
02		-	
03		+	
04*		-	
05		+	
66		+	
06		+	
08*		+	
10*		+	
12*		+	
15		-	
16		+	
17		+	
14*		-	
28*		-	

## ATTENTION

- (\*) Spool with price increasing
- With spools 15 / 16 / 17 only the mounting E / F are possible
- 19 / 20 / 21 spool not planned for AD5E...J\*
- For lever operated the spools used are different. Available spools for this kind of valve see AD5L..

ONE SOLENOID, SIDE B "F" MOUNTING			
Spool type		Covering	Transient position
01		+	
02		-	
03		+	
04*		-	
05		+	
66		+	
06		+	
08*		+	
10*		+	
22*		+	
12*		+	
13*		+	
07*		+	
15		-	
16		+	
17		+	
14*		-	
28*		-	

TWO SOLENOIDS "D" MOUNTING			
Spool type		Covering	Transient position
19*		-	
20*		+	
21*		+	

# AD5E... SOLENOID OPERATED VALVES CETOP 5

1



A max. counter-pressure of 4 bar at T is permitted for the variant with a microswitch (MS).

Max. pressure ports P/A/B	350 bar
Max. pressure port T (DC coil) see note (*)	160 bar
Max. pressure port T (AC coil)	160 bar
Max. flow	100 l/min
Max. excitation frequency	3 Hz
Duty cycle	100% ED
Fluid viscosity	10 ÷ 500 mm <sup>2</sup> /s
Fluid temperature	-25°C ÷ 75°C
Ambient temperature	-25°C ÷ 60°C
Max. contamination level	class 10 in accordance with NAS 1638 with filter $\beta_{25} \geq 75$
Weight (with one DC solenoid)	4 Kg
Weight (with two DC solenoids)	5,1 Kg
Weight (with one AC solenoid)	3,5 Kg
Weight (with two AC solenoids)	4,3 Kg

(\*) Pressure dynamic allowed for 2 millions of cycles.

## OVERALL DIMENSIONS

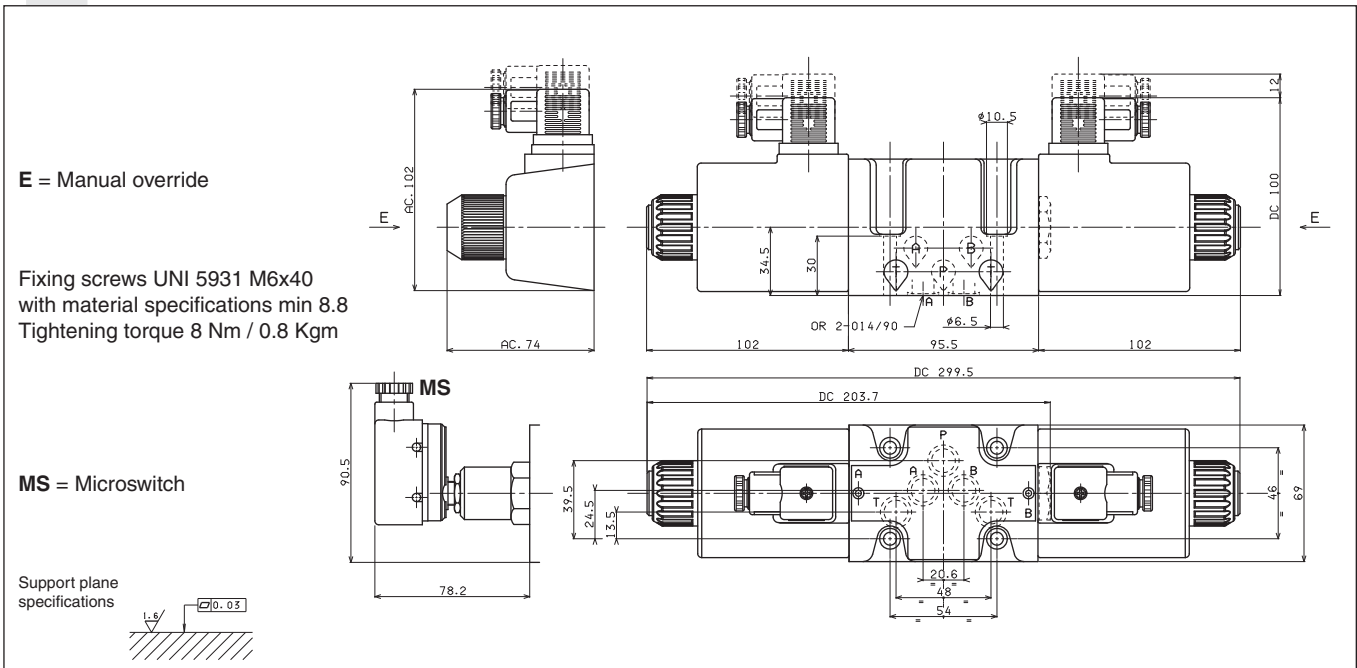

## LIMITS OF USE (MOUNTING C-E-F)

The tests have been carried out with solenoids at operating temperature and a voltage 10% less than rated voltage with a fluid temperature of 40°C. The fluid used was a mineral oil with a viscosity of 46 mm<sup>2</sup>/s at 40°C.

The values in the diagram refer to tests carried out with the oil flow in two directions simultaneously T = 2 bar (e.g. from P to A and the same time B to P).

In the cases where valves 4/2 and 4/3 were used with the flow in one direction only, the limits of use could have variations which may even be negative. Rest time: the values are indicative and depend on the following parameters: hydraulic circuit, fluid used and variations in hydraulic scales (pressure P, flow Q, temperature T).

Direct current :	Energizing	60 ÷ 95 ms.	Alternating current:	Energizing	12 ÷ 30 ms.
	De-energizing	25 ÷ 70 ms.		De-energizing	10 ÷ 55 ms.

**NOTE: The operating limits shown are valid for mountings C, E, F.**

### DIRECT CURRENT SOLENOIDS (DC)

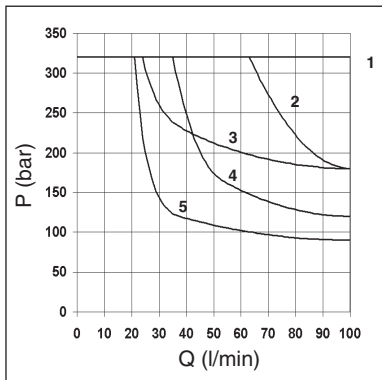

Spool type	DC	AC
	01	1
02	1	6
03	2	7
04	4	10
05	1	6
06 - 66	3	9
14-28	5	11
15	3	10
16	1	6
Curves		

### ALTERNATING CURRENT SOLENOIDS (AC)

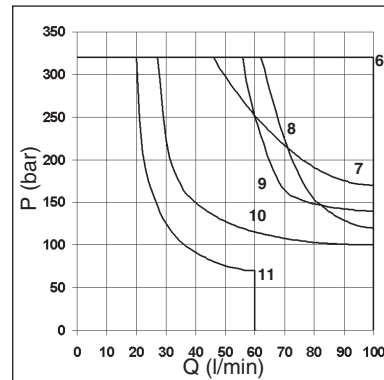

# AD5E...J\* VALVES WITH SPOOL MOVEMENT SPEED CONTROL VARIANT J\*

## Valves type AD5E... with spool movement speed control.

These ON-OFF type valves are used when a lower spool movement speed than usual for conventional solenoid valves is required to prevent impacts which could adversely affect the smooth running of the system. The system consists of reducing the transfer section for the fluid from one solenoid to the other by means of calibrated orifice.

• This version can only be used with a direct current (DC) and also involves a **reduction in the limits of use so that we suggest to always test the valve in your application.**

• To order AD5J\* version valves, specify the orifices code.

• The operation is linked to a minimum counter-pressure on the T line (1 bar min.)

• The switching time referred to the spool travel detected by a LVDT transducer can vary for the NG10 valve a minimum of 200 to a maximum of 400 ms depending on 5 fundamental variables:

- 1) Diameter of the calibrated orifice (see table)
- 2) Hydraulic power for clearance referring to flow and pressure values through the valve
- 3) Spool type
- 4) Oil viscosity and temperature
- 5) Counter-pressure at T line

• **Possible mounting: C / E / F / G / H**

• **19 / 20 / 21 spools not planned for AD5E...J\***

CALIBRATED ORIFICE AVAILABLE		
ø (mm)	M6x6	Code
0.5	M89.10.0031	<b>5S</b> (J5+S1)*
0.6	M89.10.0026	<b>6S</b> (J6+S1)*
0.7	M89.10.0032	<b>7S</b> (J7+S1)*
0.8	M89.10.0033	<b>8S</b> (J8+S1)*

\* Old code

EAD5E...J\$ - 00/2000/e

Max. pressure ports P/A/B	320 bar
Max. pressure port T - see note (*)	250 bar
Max. flow	100 l/min
Max. excitation frequency	2 Hz
Duty cycle	100% ED
Fluid viscosity	10 ÷ 500 mm <sup>2</sup> /s
Fluid temperature	-25°C ÷ 75°C
Ambient temperature	-25°C ÷ 60°C
Weight with one DC solenoid	3,6 Kg
Weight with two DC solenoids	4,5 Kg

(\*) Pressure dynamic allowed for 2 millions of cycles.

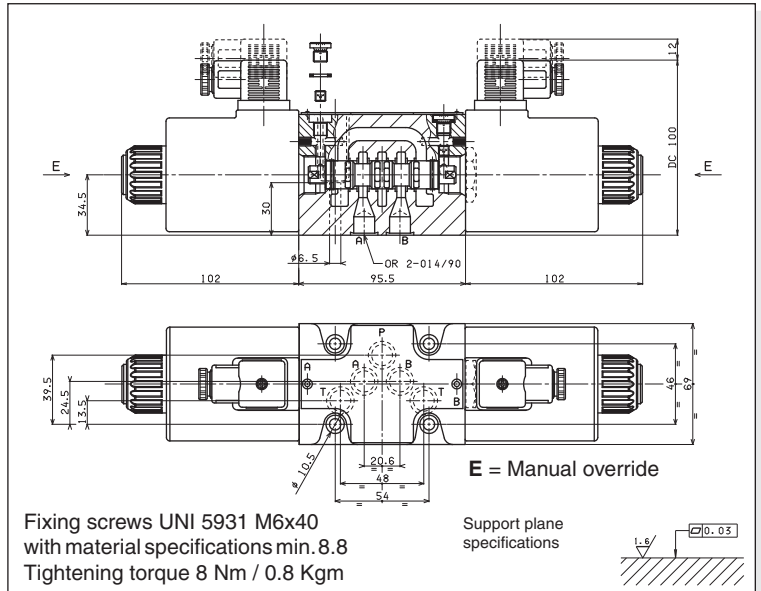

# AD5E...Q5 VALVES WITH EXTERNAL DRAINING SOLENOID - VARIANT Q5

## Valves type AD5E...Q5 with external draining solenoid.

This involves valves with solenoid drainage chambers separated by line T in the CETOP 5 interface distinguished by the letter L. This solution makes it possible to operate with a maximum counter-pressure at T up to 320 bar using only 12.9 material fixing screws to ensure the maximum safety of the solenoid valve fixing and use of an additional drain. This version can be used for direct current (DC) and alternating current (AC), but involves a reduction in the limits of usage depending on the pressure at T.

• **Mounting possible: C / D / E / F / G / H / I / L / M**

• **For subplate see BSH531..**

Max. pressure ports P/A/B/T	320 bar
Max. pressure port L (DC coils) see note (*)	250 bar
Max. pressure port L (AC coils)	160 bar
Max. flow	100 l/min
Max. excitation frequency	2 Hz
Duty cycle	100% ED
Fluid viscosity	10 ÷ 500 mm <sup>2</sup> /s
Fluid temperature	-25°C ÷ 75°C
Ambient temperature	-25°C ÷ 60°C
Weight with one DC solenoid	3,6 Kg
Weight with two DC solenoids	4,5 Kg
Weight with one AC solenoid	3,5 Kg
Weight with two AC solenoids	4,3 Kg

(\*) Pressure dynamic allowed for 2 millions of cycles.

## OVERALL DIMENSIONS

EAD5E...Q5 - 02/2000/e

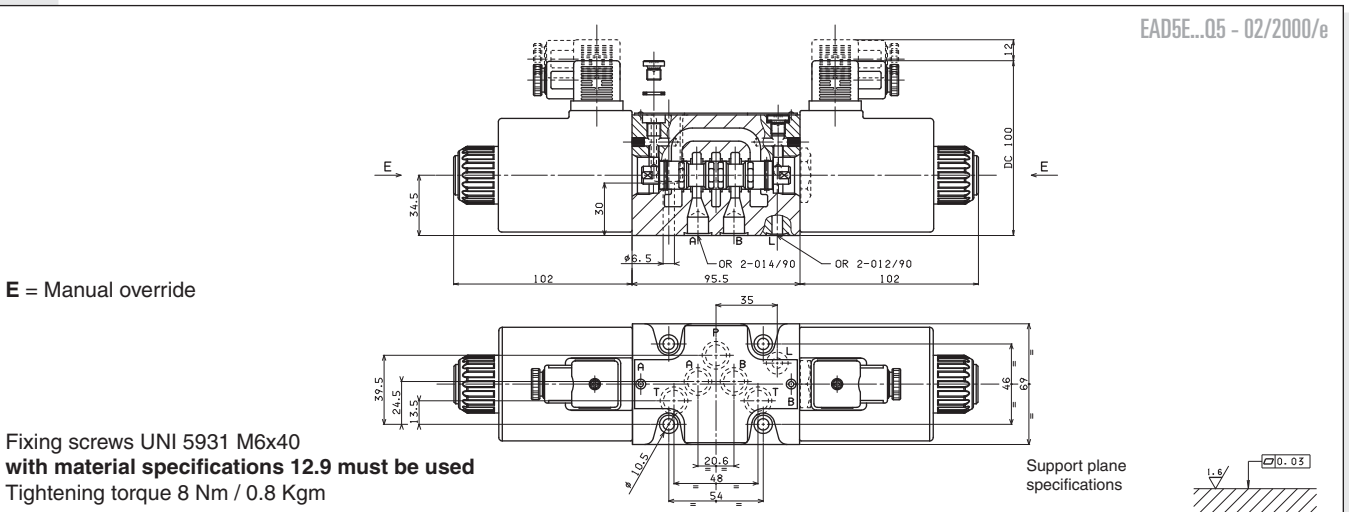

# AD50... OLEO-PNEUMATIC OPERATION TYPE VALVES CETOP 5

1



Max. pressure ports P/A/B	320 bar
Max. pressure port T	160 bar
Max. flow	100 l/min
Min. operating pressure	4 + [0.027 x (pt*)] bar - see note
Max. operating pressure	200 bar
Fluid viscosity	10 ÷ 500 mm <sup>2</sup> /s
Fluid temperature	-25°C ÷ 75°C
Ambient temperature	-25°C ÷ 60°C
Max. contamination level	class 10 in accordance with NAS 1638 with filter $\beta_{25} \geq 75$
Weight (single pilot)	4,1 Kg
Weight (twin pilot)	5,4 Kg

- Possible mounting:  
Hydraulic control:  
**C / D / E / F / G / H / I / L / M**  
Pneumatic control:  
**I / L / M**

• Ordering code see Cap. I • 34

(pt\*) = Pressure at port T

## OVERALL DIMENSIONS

Fixing screws UNI 5931 M6x40 with material specifications min. 8.8  
Tightening torque 8 Nm / 0.8 Kg

Support plane specifications

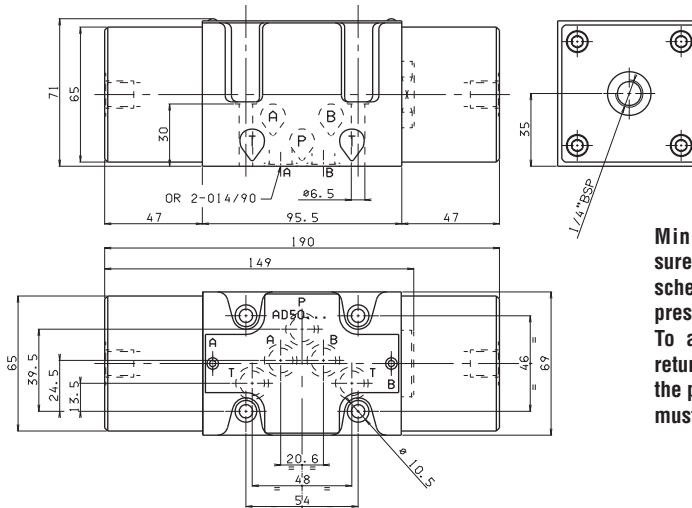
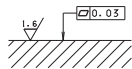

Minimum pilot pressure depends on spool scheme, flow rate and pressure.  
To allow the spool to return to neutral position, the pilot pressure must be below 2 bar.

EAD50 - 02/2000/e

# AD5D... DIRECT MECHANICALLY OPERATED TYPE VALVES CETOP 5



Max. pressure ports P/A/B	320 bar
Max. pressure port T	20 bar
Max. flow	100 l/min
Operating force - see note (*)	8 Kg - see note (**)
Fluid viscosity	10 ÷ 500 mm <sup>2</sup> /s
Fluid temperature	-25°C ÷ 75°C
Ambient temperature	-25°C ÷ 60°C
Max. contamination level	class 10 in accordance with NAS 1638 with filter $\beta_{25} \geq 75$
Weight	3,8 Kg

- Possible mounting:  
**E / F / G / H**
- Ordering code see Cap. I • 34

• Notes:  
(\*) In the absence of counter-pressure at port T

(\*\*) 10 Kg with a pressure of 20 bar at T

## OVERALL DIMENSIONS

Fixing screws UNI 5931 M6x40 with material specifications min. 8.8  
Tightening torque 8 Nm / 0.8 Kg

Support plane specifications

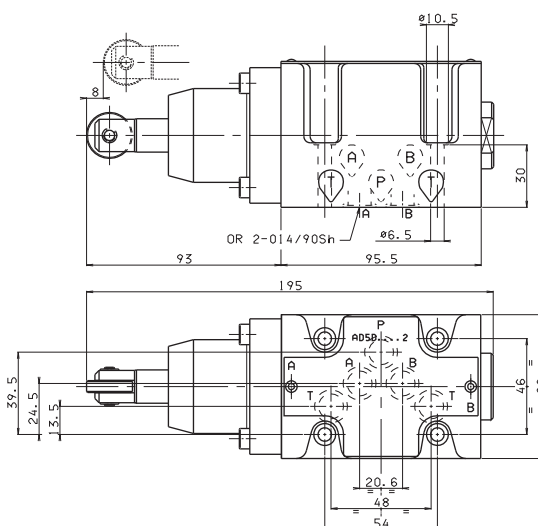
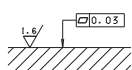

Stroke	8 mm
Extra stroke	2 mm
Working stroke	4 mm

EAD5D - 03/2000/e





## AD5L... LEVER OPERATED TYPE VALVES CETOP 5

Max. pressure ports P/A/B	320 bar
Max. pressure port T	160 bar
Max. flow	100 l/min
Lever angle	2 x 15°
Fluid viscosity	10 ÷ 500 mm <sup>2</sup> /s
Fluid temperature	-25°C ÷ 75°C
Ambient temperature	-25°C ÷ 60°C
Max. contamination level	class 10 in accordance with NAS 1638 with filter β <sub>25</sub> ≥ 75
Weight	4,7 Kg
Weight with M1 variant	5,35 Kg

- Possible mounting: **C / E / F** (with mounting "F" and spools "15-16-17" the lever is on side "B")
- There is no **D** type mounting
- The variant **D1** specifies the detent (mechanical connection) for lever operation
- The springs for the version with detent (variant **D1**) are different from those for standard versions.

<b>AD5L...</b>	
ORDERING CODE	CAP. I • 34
STANDARD SPOOLS	CAP. I • 35

- Completely different spools are used for these (lever operated) valves than for all other types of operation (e.g. electrical, mechanical, pneumatic operation, .....
- Available spools: 01 / 02 / 03 / 04 / 05 / 06 / 66 / 07 / 22 / 13 / 15 / 16 / 17 (for hydraulic symbols see Cap. I • 35).
- Microswitch type AM1107 code V79000001 can be ordered separately.

### OVERALL DIMENSIONS

M1 = Microswitch

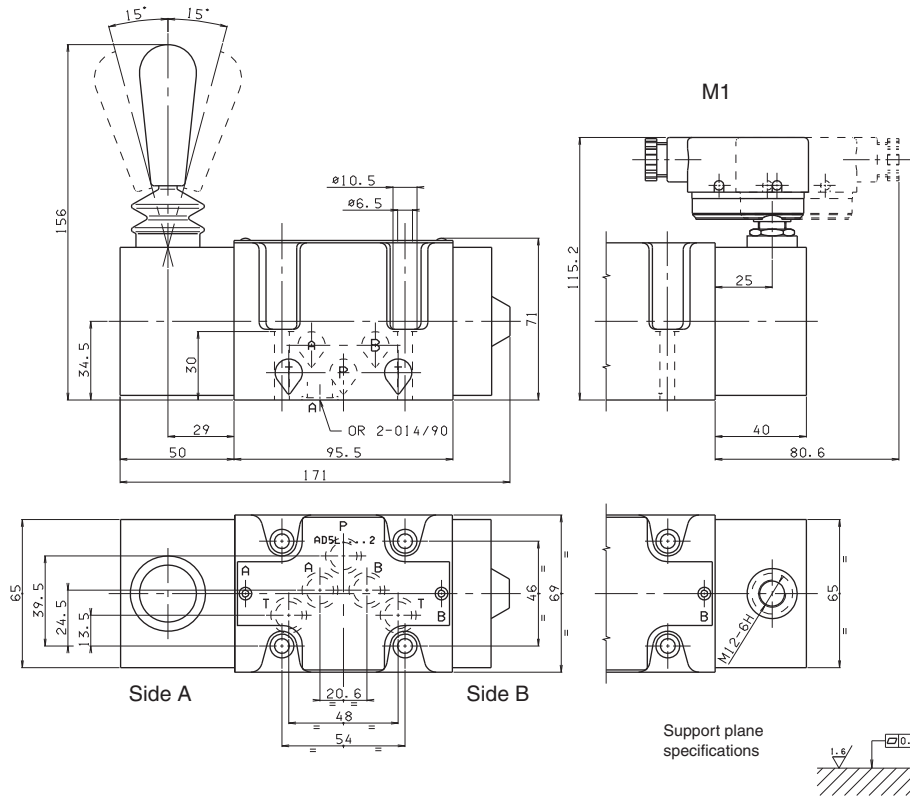

Fixing screws UNI 5931 M6x40  
with material specifications min. 8.8  
Tightening torque 8 Nm / 0.8 Kgm



## "A16" DC COILS FOR CETOP 5

Type of protection (in relation to the connector used)	IP 65
Number of cycles	18.000/h
Supply tolerance	±10%
Ambient temperature	-30°C ÷ 60°C
Duty cycle	100% ED
Insulation class wire	H
Weight	0,9 Kg

VOLTAGE (V)	MAX WINDING TEMPERATURE (AMBIENT TEMPERATURE 25°C)	RATED POWER (W)	RESISTANCE AT 20°C (OHM) ±7%
12V	106°C	45	3.2
24V	113°C	45	12.4
48V*	-	45	-
102V(**)	-	45	-
110V(**)	118°C	45	268
205V(**)	-	45	-

\* Special voltages

\*\* The european low voltage directive is applied to electrical equipments used at a nominal voltages between 50 and 1000 VAC or 75 and 1500 VDC. In conformity with the low directive each part of the manifold or the subplate on which the valve is mounted should be connected to a protective earth with a resistance less than 0.1 ohms.

### EMERGENCY (COILS WITH HIRSCHMANN CONNECTION)

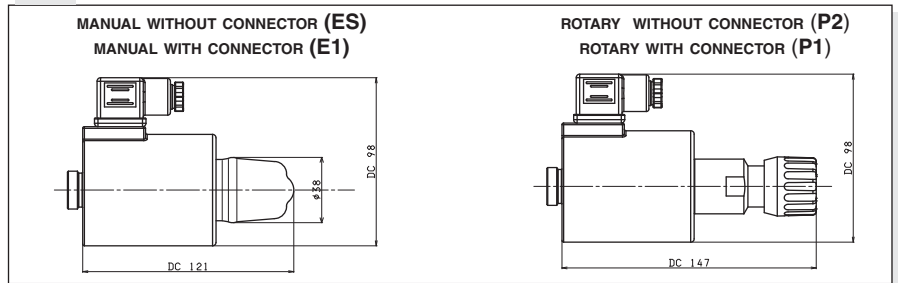

## "K16" AC SOLENOIDS FOR CETOP 5

Type of protection (in relation to the connector used)	IP 66
Number of cycles	18.000/h
Supply tolerance	+10% / -10%
Ambient temperature	-54°C ÷ 60°C
Duty cycle	100% ED
Max. pressure static	210 bar
Insulation class wire	H
Weight	0,8 Kg

VOLTAGE (V)	MAX. WINDING TEMPERATURE (AMBIENT TEMPERATURE 25°C)	RATED POWER (VA)	IN RUSH CURRENT (VA)	RESISTANCE AT 20°C (OHM) ±10%
24V/50Hz	134°C	124	454	0.56
24V/60Hz*	115°C	103.5	440	0.55
48V/50Hz*	134°C	113	453	2.10
115V/50Hz-120V/60Hz(**)	121°C - 138°C	121-101	471-487	10.8
230V/50Hz-240V/60Hz(**)	121°C - 138°C	120-101	478-485	43.0
240V/50Hz(**)	134°C	120	456	47.39

\* Special voltage

\*\* The european low voltage directive is applied to electrical equipments used at a nominal voltages between 50 and 1000 VAC or 75 and 1500 VDC. In conformity with the low directive each part of the manifold or the subplate on which the valve is mounted should be connected to a protective earth with a resistance less than 0.1 ohms.

### EMERGENCY (COILS WITH HIRSCHMANN CONNECTION)

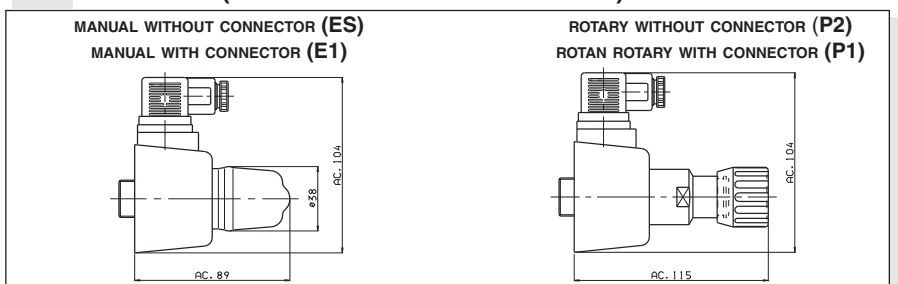

# ADP5E... DIRECTIONAL CONTROL CETOP 5

## HIGH PERFORMANCES SOLENOID OPERATED VALVES



ADP5E...	
"D19" DC SOLENOIDS	CAP. I • 43
STANDARD CONNECTORS	CAP. I • 20

The NG10 directional control valves are designed for subplate mounting with an interface in accordance with UNI ISO 4401 - 05 - 04 - 0 - 94 standard (ex CETOP R 35 H 4.2-4-05). The use of solenoids with wet armatures allows an extremely safe construction completely dispensing with the need for dynamic seal. The solenoid tube is screwed directly onto the valve casing whilst the coil is kept in position by a ring nut. Great care has been taken over the design and production of the ducts and the improvement of the spools allows relatively high flow rates to be accommodated for its size with minimal pressure drops ( $\Delta p$ ). The operation of the directional valve is electrical. The centring is achieved by means of calibrated length springs which, once the impulse is over, immediately reposition the spool in the neutral position. The solenoids, constructed with a protection class of IP66 in accordance with BS 5490 standards, are available in direct current form and different voltage. The electrical controls are equipped with an emergency manual control inserted in the tube.

The ADP.5.E.. valve has certain design features which allow it to "manage" a hydraulic power equal to  $Q = 120\text{l/min}$  with a  $P = 320\text{ bar}$ , maintaining a considerable safety margin. These features can be summarized as follows:

- Solenoid D19 with an optimum ratio between the power absorbed (42W) and the magnetic force
- Diameter of the spool 18 mm, with carefully designed geometry improved to compensate for the flow forces
- Compact graphite cast iron valve casing with high mechanical resistance
- Different springs, improved according to the features of the spool

The electrical supply connectors meet DIN 43650 ISO 4400 standards; connectors are also available with built in rectifiers or pilot lights.

The recommended fluids are hydraulic mineral based oils in accordance with DIN 51524 and it is recommended that filters should be fitted to ensure a maximum contamination level of class 10 in accordance with NAS 1638,  $\beta_{25} \geq 75$ .

For other fluids please contact our technical department.

• The solenoids are in DC voltage only

### PRESSURE DROPS

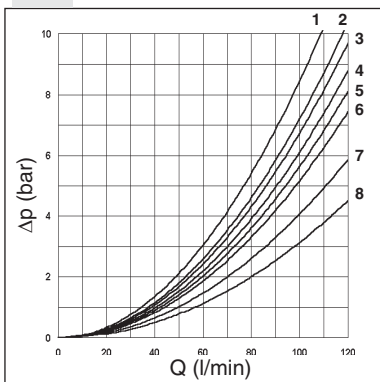

The diagram at the side shows the pressure drop curves for spools during normal usage. The fluid used is a mineral oil with a viscosity of  $46\text{ mm}^2/\text{s}$  at  $40^\circ\text{C}$ ; the tests have been carried out at a fluid temperature of  $40^\circ\text{C}$ . For higher flow rates than those in the diagram, the losses will be those expressed by the following formula:

$$\Delta p_1 = \Delta p \times (Q_1/Q)^2$$

where  $\Delta p$  will be the value for the losses for a specific flow rate  $Q$  which can be obtained from the diagram,  $\Delta p_1$  will be the value of the losses for the flow rate  $Q_1$  that is used.

Spool type	Connections				
	P→A	P→B	A→T	B→T	P→T
01	4	4	7	7	
02	6	6	8	8	7
03	3	3	8	8	
04	4	4	2	2	3
05	6	6	6	6	
66	4	4	8	7	
06	4	4	7	8	
14	6	4	8	6	2
15-19	2	2	5	5	
16-20	1	1	2	2	
28	4	6	6	8	2

Curve No.

### ORDERING CODE

<b>ADP</b>	High performances directional control valve
<b>5</b>	CETOP 5/NG10
<b>E</b>	Electrical operator
<b>**</b>	Spools (Table next page)
<b>*</b>	Mounting (table 1)
<b>*</b>	Voltage (table 2)
<b>**</b>	Variants (table 3)
<b>1</b>	Serial No.

### TAB.3 - VARIANTS

VARIANT	CODE
No variant (without connectors)	S1(*)
Viton	SV(*)
Rotary emergency button	P2(*)
Adjustable spool movement speed control	4S(*)
With solenoid chamber external drainage (Y)	S5(*)
Spool movement speed control (VDC only) with $\varnothing 0.5\text{ mm}$ $\varnothing$ orifice	5S(*)
Spool movement speed control VDC only) with $\varnothing 0.8\text{ mm}$ $\varnothing$ orifice	8S(*)
Other variants available on request	

(\*) Coils with Hirschmann connection supplied without connectors. The connectors can be ordered separately, c Cap. I • 20.

### TAB.1 - MOUNTING

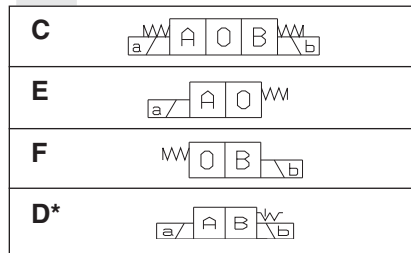

(\*) Valve with detent

### TAB.2 - TYPE E CONTROL

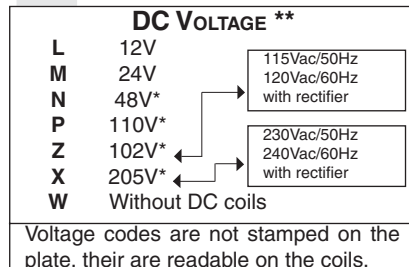

Voltage codes are not stamped on the plate, they are readable on the coils.

\* Special voltage

\*\* Technical data see Cap. I • 43

## STANDARD SPOOLS

\* SPOOLS WITH PRICE INCREASING

TWO SOLENOIDS, SPRING CENTRED "C MOUNTING"			
Spool type		Covering	Transient position
01		+	
02		-	
03		-	
04*		-	
05		-	
66		-	
06		-	
14*		-	
28*		-	

TWO SOLENOIDS "D MOUNTING"			
Spool type		Covering	Transient position
19*		-	
20*		+	

ONE SOLENOID, SIDE A "E MOUNTING"			
Spool type		Covering	Transient position
01		+	
02		-	
03		-	
04*		-	
05		-	
66		-	
06		-	
14*		-	
15		-	
16		+	
28*		-	

ONE SOLENOID, SIDE B "F MOUNTING"			
Spool type		Covering	Transient position
01		+	
02		-	
03		-	
04*		-	
05		-	
66		-	
06		-	
14*		-	
15		-	
16		+	
28*		-	

## LIMITS OF USE (MOUNTING C-E-F)

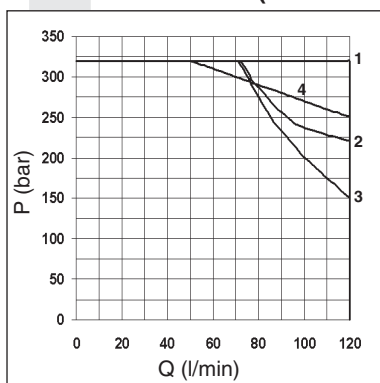

Spool type	n° curves
01	1
02	1
03	2
04	1
05	1
66	1
06	1
14	3
15	1
16	1
28	3
19	4
20	4

The tests have been carried out with solenoids at operating temperature and a voltage 10% less than rated voltage with a fluid temperature of 50°C.

The fluid used was a mineral oil with a viscosity of 46 mm<sup>2</sup>/s at 40°C.

The values in the diagram refer to tests carried out with the oil flow in two directions simultaneously (e.g. from P to A and at the same time B to T).

**In the cases where valves 4/2 and 4/3 were used with the flow in one direction only, the limits of use could have variations which may even be negative.**

The tests were carried out with a counter-pressure of 2 bar at T.

# ADP5E... HIGH PERFORMANCES SOLENOID OPERATED VALVE CETOP 5

1

**ADP5.E... 4S variant** - These ON-OFF type valves are used when a lower spool movement speed is required than it is generally available with a conventional solenoid valve in order to avoid those shocks which might otherwise compromise proper system operation. This is obtained by forcing the fluid to pass through the gap which exists between the screw thread and the M8x1 tapped thread, restricting in this way the transfer cross section between the 2 solenoid chambers. Using this variant may entail a reduction in the operational limits according to the spool used, up to the complete blocking of the change over itself. The valve operation depends on the presence of a minimum back pressure on the T line (min. 1 bar). The change over time referred to the spool stroke depends on 4 main variables:

- Applicable hydraulic power, related to the flow rate and pressure drop across the valve;
- Spool type (system configuration);
- Oil viscosity and temperature;
- Back pressure on T.

Max. operating pressure: ports P/A/B	350 bar
Max. operating pressure: port T (*)	250 bar
Max. flow	120 l/min
Max. excitation frequency	3 Hz
Duty cycle	100% ED
Fluid viscosity	10 ÷ 500 mm <sup>2</sup> /s
Fluid temperature	-25°C ÷ 75°C
Ambient temperature	-25°C ÷ 60°C
Max. contamination level	class 10 in accordance with NAS 1638 with filter β <sub>25</sub> ≥ 75
Weight with one DC solenoid	5 Kg
Weight with two DC solenoids	6,5 Kg

(\*) Pressure dynamic allowed for 2 millions of cycles  
 Pressure on port T valid in case Y is blocked (no external drainage). Normally the external drained is blocked with a plug S.T.E.I M6x6 UNI 5923

**ADP5.E... S5 variant** - These are valves with solenoid chambers drainage separated from the T line, obtained on CETOP RO5 interface and characterized by the letter Y. This solution allows operation with up to 320 bar max. back pressure on the T line while using only 12.9 material fixing screws to ensure maximum solenoid valve mounting safety and supplementary drainage.

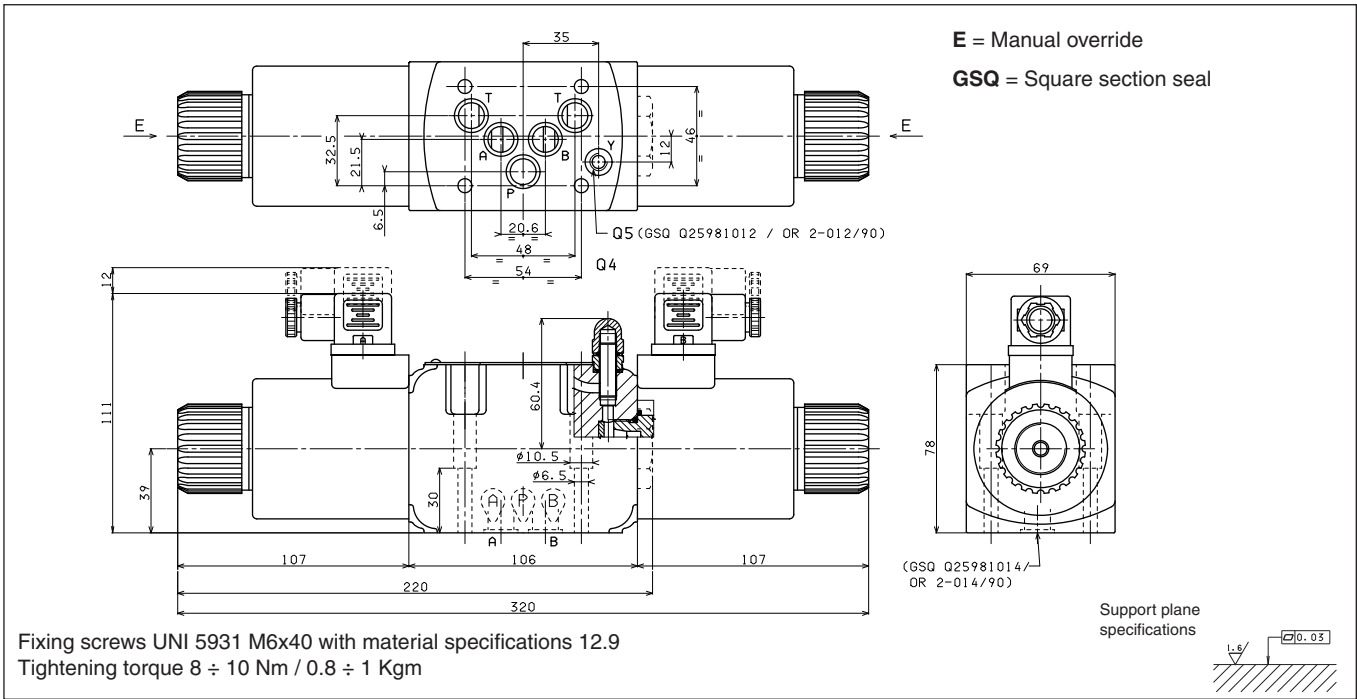

## “D19” DC SOLENOIDS

Type of protection (in relation to the connector used)	IP 66
Number of cycle	18.000/h
Supply tolerance	±10%
Ambient temperature	-54°C ÷ 60°C
Duty cycle	100% ED
Max static pressure	210 bar
Insulation class wire	H
Weight	1,63 Kg

### ROTARY EMERGENCY

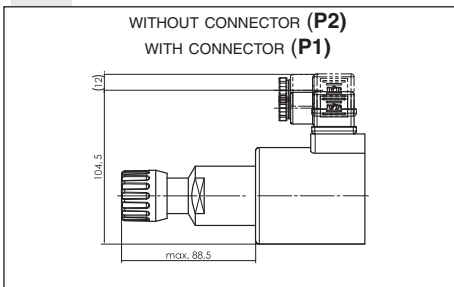

VOLTAGE (V)	MAX WINDING TEMPERATURE (AMBIENT TEMPERATURE 25°C)	RATED POWER (W)	RESISTANCE AT 20°C (OHM) ±10%
12V	105°C	42	3.43
24V	105°C	42	13.71
48V*	105°C	42	55
102V(*)(**)	105°C	42	248
110V(*)(**)	105°C	42	288
205V(*)(**)	105°C	42	1000

\* Special voltage

\*\* The european low voltage directive is applied to electronic equipments used at a nominal voltages between 50 and 1000 VAC or 75 and 1500 VDC. In conformity with the low directive each part of the manifold or the subplate on which the valve is mounted should be connected to a protective earth with a resistance less than 0.1 ohms.



## ADP5V... WITH PROXIMITY SENSOR LVDT CETOP 5

The NG10 directional control valves are designed for subplate mounting with an interface in accordance with UNI ISO 4401-05 - 04 - 0 - 94 standard (ex CETOP R 35 H 4.2-4-05).

The single solenoid directional valves type ADP5V are used in applications where the monitoring of the position of the spool inside the valve is requested to manage the machine safety cycles in accordance with the accident prevention legislation. These directional valves are equipped with an horizontal positioned

inductive sensor on the opposite side of the solenoid, which is capable of providing the first movement of the valve when the passage of a minimum flow is allowed. Integrated in safety systems, these valves intercept actuator movements that could be dangerous for the operators and for the machine.

Max. operating pressure: ports P/A/B	350 bar
Max. operating pressure: port T (*)	250 bar
Max. flow	120 l/min
Max. excitation frequency	3 Hz
Duty cycle	100% ED
Fluid viscosity	10 ÷ 500 mm <sup>2</sup> /s
Fluid temperature	-25°C ÷ 75°C
Ambient temperature	-25°C ÷ 60°C
Max. contamination level	class 10 in accordance with NAS 1638 with filter β <sub>25</sub> ≥ 75
Type of protection (in relation to connector used)	IP 66
Weight	6,2 Kg

(\*) Pressure dynamic allowed for 2 millions of cycles

### ADP5V...

"D19" DC SOLENOIDS	CAP. I • 44
STANDARD CONNECTORS	CAP. I • 20
L.V.D.T.	CAP. I • 22

### PRESSURE DROPS

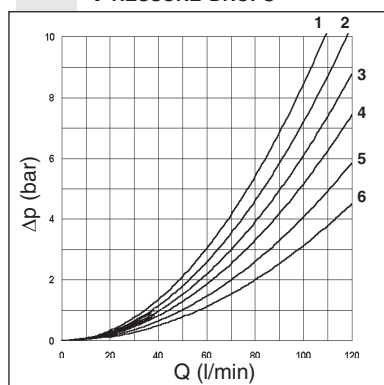

The diagram at the side shows the pressure drop curves for spools during normal usage. The fluid used is a mineral oil with a viscosity of 46 mm<sup>2</sup>/s at 40°C; the tests have been carried out at a fluid temperature of 40°C. For higher flow rates than those in the diagram, the losses will be those expressed by the following formula:

$$\Delta p_1 = \Delta p \times (Q_1/Q)^2$$

where Δp will be the value for the losses for a specific flow rate Q which can be obtained from the diagram, Δp<sub>1</sub> will be the value of the losses for the flow rate Q<sub>1</sub> that is used.

Spool type	Connections				
	P→A	P→B	A→T	B→T	P→T
01	3	3	5	5	
02	4	4	6	6	5
66	3	3	6	5	
06	3	3	5	6	
16	1	1	2	2	

Curve No.

### ORDERING CODE

<b>ADP</b>	High performances directional control valve
<b>5</b>	CETOP 5/NG10
<b>V</b>	Directional valve with single solenoid and LVDT proximity sensor
<b>***</b>	Spool and mounting (table 1)
<b>*</b>	Voltage (table 2)
<b>**</b>	Variants (table 3)
<b>1</b>	Serial No.

### TAB.2 - DC VOLTAGE \*\*

<b>L</b> 12V	115Vac/50Hz 120Vac/60Hz with rectifier
<b>M</b> 24V	
<b>N</b> 48V*	230Vac/50Hz 240Vac/60Hz with rectifier
<b>P</b> 110V*	
<b>Z</b> 102V*	
<b>X</b> 205V*	
<b>W</b> Senza bobina né connettori	

Voltage codes are not stamped on the plate, they are readable on the coils.

\* Special voltage

\*\* Technical data see Cap. I • 45

### TAB1 - STANDARD SPOOL FOR ADP5V

Spool type	E / F MOUNTING POSSIBLE	
	Covering	Transient position
<b>01E</b>	+	
<b>01F</b>	+	
<b>02E</b>	-	
<b>02F</b>	-	
<b>66E</b>	-	
<b>06F</b>	-	
<b>16E</b>	+	
<b>16F</b>	+	
<b>32E</b>	+	

### TAB.3 - VARIANTS

VARIANTS	CODE
No variant (without connectors)	S1(*)
Rotary emergency button	P2(*)
Without proximity connector LVDT	S3
Without coils and proximity connector	S4
With solenoid chamber external drainage (Y)	
Other variants available on request.	

(\*) Coils with Hirschmann connection supplied without connectors. The connectors can be ordered separately, Cap. I • 20.

**CE** registered mark for industrial environment with reference to the electro-magnetic compatibility.

European norms:

- EN50082-2 general safety norm - industrial environment
- EN 50081-1 emission general norm - residential environment

# ADP5V... WITH PROXIMITY SENSOR LVDT CETOP 5

## OVERALL DIMENSIONS

E = Manual override

GSQ = Square section seal

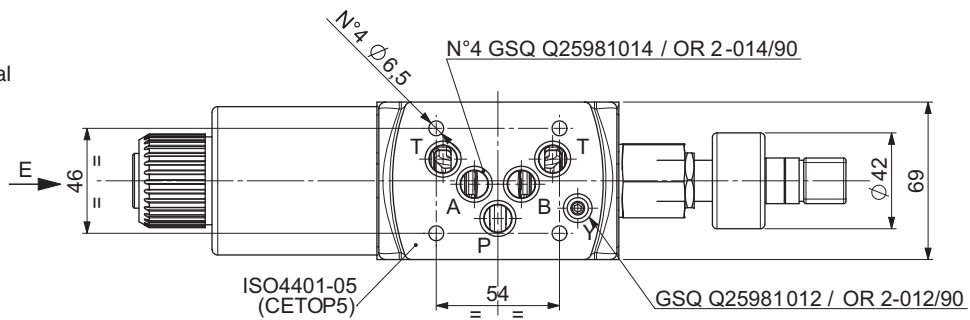

Fixing screws UNI 5931 M6x40  
with material specifications 12.9  
Tightening torque  
8 ÷ 10 Nm / 0.8 ÷ 1 Kgm

Support plane  
specifications

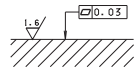

1



## “D19” DC SOLENOIDS

Type of protection (in relation to the connector used)	IP 66
Number of cycle	18.000/h
Supply tolerance	±10%
Ambient temperature	-25°C ÷ 60°C
Duty cycle	100% ED
Max static pressure	210 bar
Insulation class wire	H
Weight	1,63 Kg

## ROTARY EMERGENCY

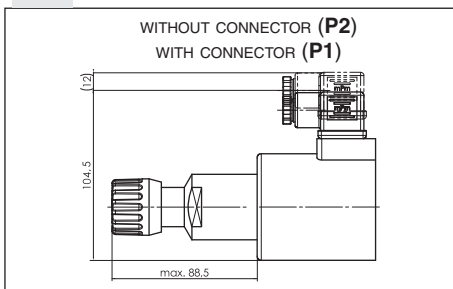

VOLTAGE (V)	MAX WINDING TEMPERATURE (AMBIENT TEMPERATURE 25°C)	RATED POWER (W)	RESISTANCE AT 20°C (OHM) ±10%
12V	105°C	42	3.43
24V	105°C	42	13.71
48V*	105°C	42	55
102V(**)**	105°C	42	248
110V(**)**	105°C	42	288
205V(**)**	105°C	42	1000

\* Special voltage

\*\* The european low voltage directive is applied to electrical equipments used at a nominal voltages between 50 and 1000 VAC or 75 and 1500 VDC. In conformity with the low directive each part of the manifold or the subplate on which the valve is mounted should be connected to a protective earth with a resistance less than 0.1 ohms.

## AD3I... AUTOMATIC RECIPROCATING VALVES CETOP 3



AD3I...

These automatic reciprocating valves, with interface UNI ISO 4401 - 03 - 02 - 0 - 94 standard (ex CETOP R 35 H 4.2-4-03), reverse the movement of an actuator every time the flow through the valve stops. With no max. pressure valves inside the body, the spool is moved by two springs and locked by unbalanced pressure inside valve; when no more flow is crossing the valve, the spool changes the position inverting the direction of the actuator.

Max. operating pressure port P	320 bar
Max. flow	30 l/min
Minimum permitted flow	3 l/min
Fluid viscosity	20 ÷ 200 mm <sup>2</sup> /s
Fluid temperature	-20°C ÷ 60°C
Max. contamination level(*)	class 10 in accordance with NAS 1638 with filter $\beta_{25} \geq 75$
Positioner activating force (measured with 1 bar on the T line)	130 N
Weight of version without positioner	0,95 Kg
Weight of version with positioner	1 Kg

(\*) Max contamination level must be respect to obtain the right function of the valve

With a preferential starting P → B and A → T position, these valves are mainly used to control the movement compactors or system where is not possible to use electrical device.

### ORDERING CODE

<b>AD</b>	Directional valve
<b>3</b>	CETOP 3/NG6
<b>I</b>	Automatic reciprocating valve at null flow
<b>* (1)</b>	<b>P</b> =Version with positioner to adjust the pressure relief valve of the system
<b>**</b>	<b>00</b> = No variant <b>V1</b> = Viton
<b>1</b>	Serial No.

(1) Omit if not required the positioner

Tests carried out with mineral oil at a temperature of 40°C with viscosity of 46 mm<sup>2</sup>/s.

### HYDRAULIC SYMBOL

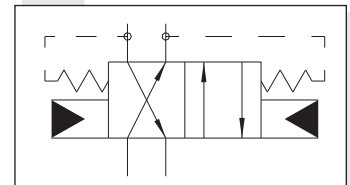

### PRESSURE DROPS

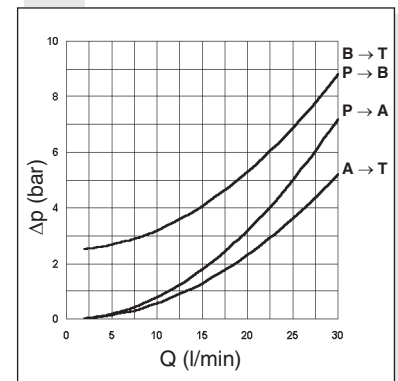

### OVERALL DIMENSIONS

With positioner (P)

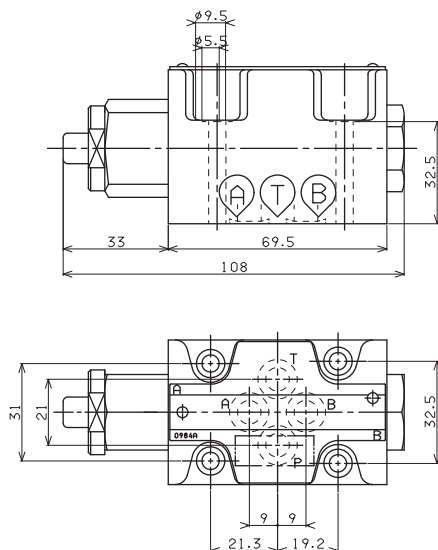

Without positioner

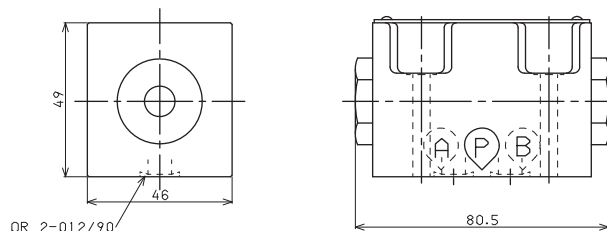

Fixing screws UNI 5931 M5x40  
with material specifications min. 8.8  
Tightening torque 5 Nm / 0.5 Kg

Support plane specifications

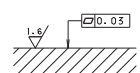



# AD3RI... AUTOMATIC RECIPROCATING VALVES CETOP 3

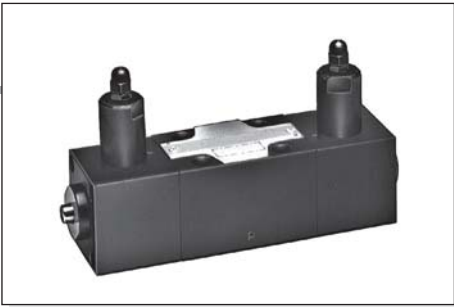

AD3RI...

This valve type is characterized by fully hydraulic operation, as it takes advantage of the system pressure rise to cause an automatic and continuous inversion of the utilization. The change-over takes place when the system pressure exceeds the inversion valves calibration pressure, and therefore also in not predetermined positions. At cylinder stroke end, the overall maximum pressure valve should be adjusted on a value 30% higher than the system operating pressure.

Max. operating pressure	320 bar
Max. pressure port T	160 bar
Min. recommended pressure	15 bar
Max. flow	25 l/min
Min. flow	2 l/min
Setting ranges:	Spring 1 15 ÷ 50 bar
	Spring 2 20 ÷ 140 bar
	Spring 3 50 ÷ 320 bar
Fluid viscosity	10 ÷ 60 mm <sup>2</sup> /s
Fluid temperature	-20°C ÷ 75°C
Max. contamination level	class 10 in accordance with NAS 1638 with filter $\beta_{25} \geq 75$
Weight	2,3 Kg

The inverter valves pressure calibration values should be 15% lower than that of the overall maximum pressure valve, and 15% higher than the maximum operating pressure.

Note: to operate the push button emergency, a minimum pressure of 3 bar on the actuator is needed.

### ORDERING CODE

- AD** Directional valve
- 3** CETOP 3/NG6
- RI** Automatic reciprocating valve hydraulically operated automatic reciprocation
- 211** Scheme
- Z** No voltage
- \*** Setting ranges:  
1 = 15 ÷ 50 bar  
2 = 20 ÷ 140 bar  
3 = 50 ÷ 320 bar
- \*\*** 00 = No variant  
V1 = Viton
- 3** Serial No.

### HYDRAULIC SYMBOL

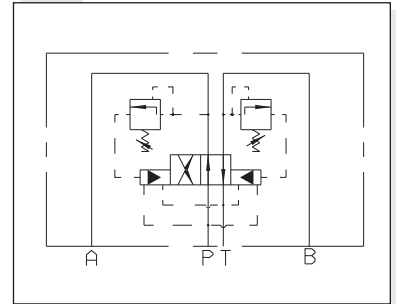

### PRESSURE DROPS

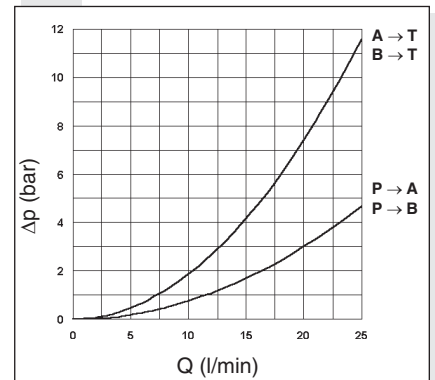

Tests carried out with mineral oil at a temperature of 40°C with viscosity of 46 mm<sup>2</sup>/s.

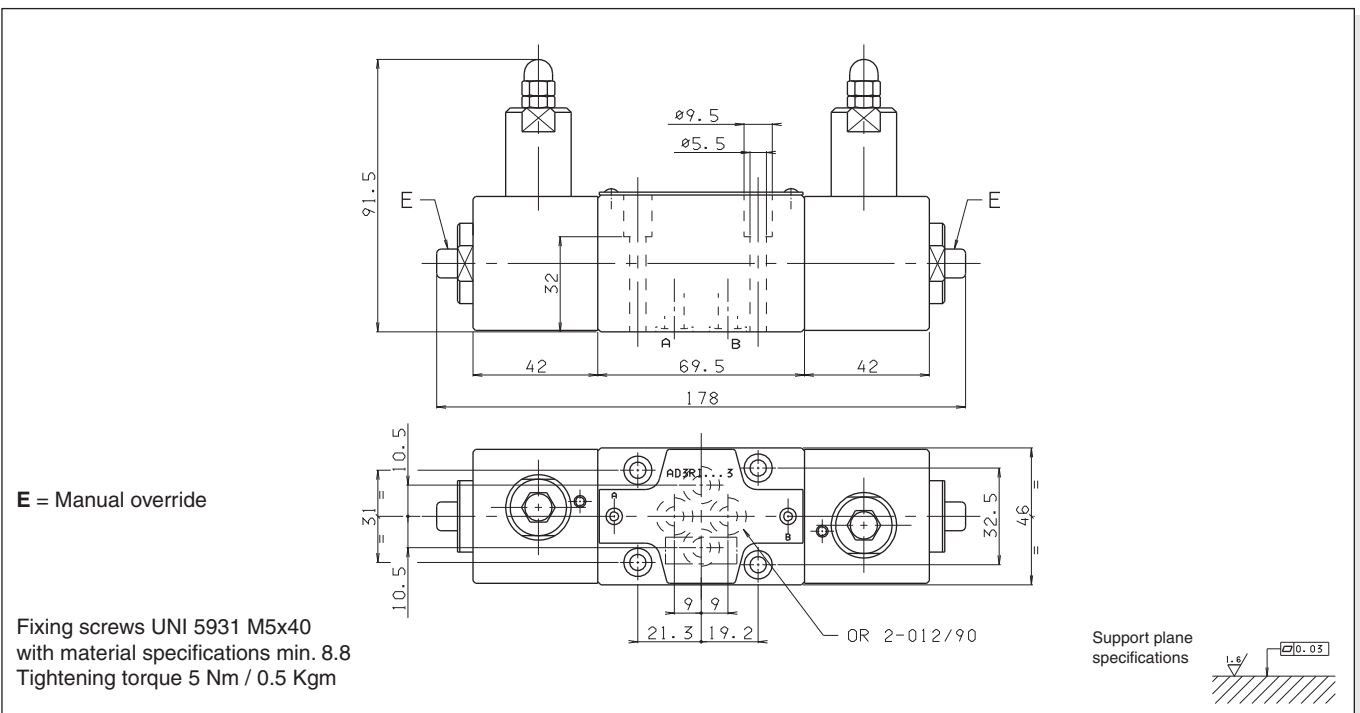

# AD5I... AUTOMATIC RECIPROCATING VALVES CETOP 5



AD5I...

The operating principle of this type of inverter valve, with interface UNI ISO 4401 - 05 - 04 - 0 - 94 standard (ex CETOP R 35 H 4.2-4-05), is based on the pressure unbalanced created in its interior as a consequence of the fluid flow rate. On starting the system this valve assumes always a preferential position P → B e A → T.

When a pressure is applied to the cylinder which exceeds the system maximum pressure relief valve setting (e.g. end stroke actuator), a hydraulic unbalanced is generated capable of changing over the valve and inverting the cylinder direction of the movement.

Max. operating pressure port P	320 bar
Max. flow	100 l/min
Minimum permitted flow	10 l/min
Fluid viscosity	32 ÷ 60 mm <sup>2</sup> /s
Fluid temperature	-20°C ÷ 60°C
Max. contamination level(*) class 10 in accordance with NAS 1638 with filter β <sub>25</sub> ≥ 75	
Positioner activating force (measured with 1 bar on the T line)	190 N
Weight of version without positioner	3,4 Kg
Weight of version with positioner	3,6 Kg

(\*) Max contamination level must be respect to obtain the right function of the valve

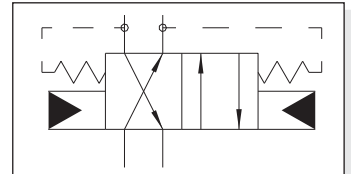

### ORDERING CODE

- AD** Directional control
- 5** CETOP 5/NG10
- I** Automatic reciprocating valve at null flow
- P** Version with positioner to adjust the pressure relief valve of the system
- \*\*** **00** = No variant  
**V1** = Viton  
**2T** = Variant for regenerative system
- 1** Serial No.

Tests carried out with mineral oil a temperature of 40°C with a viscosity of 46 mm<sup>2</sup>/s.

### PRESSURE DROPS

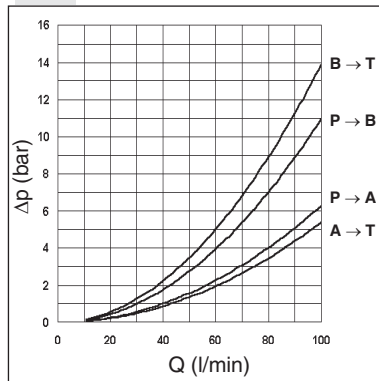

### AD5IP2T1 FOR REGENERATIVE SYSTEM

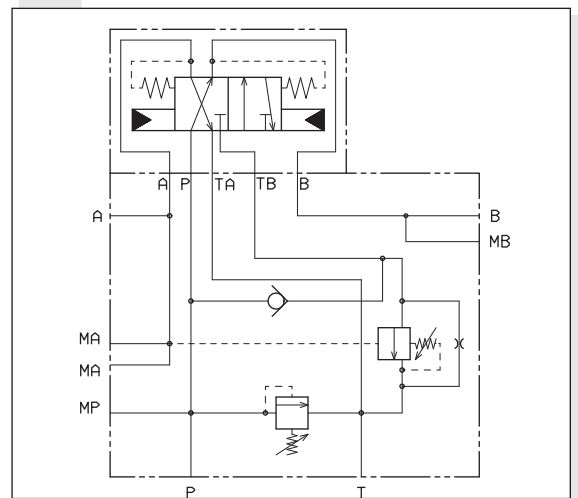

Version AD5IP2T1 integrated in a regenerative circuit for compactors with roll on-off mobile system, solution useful for all applications where to connect microswitch of proximity is not possible. For any information about our regenerative manifold please contact our technical department. For special subplate BS5RIA see Cap. X • 8.

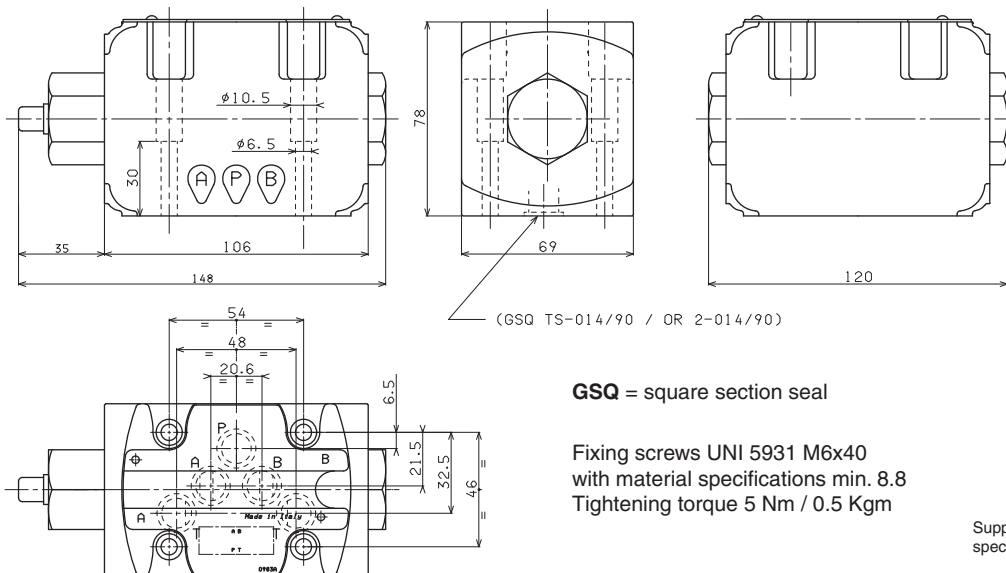

# AD5RI... AUTOMATIC RECIPROCATING VALVES CETOP 5

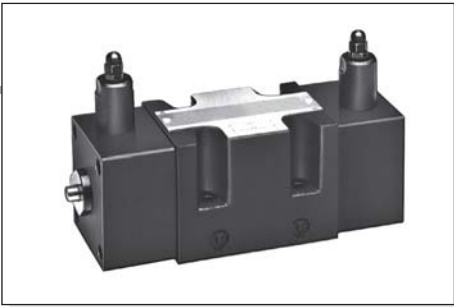

AD5RI...

This valve type is characterized by a fully hydraulic operation, as it takes advantage of the system pressure rise to cause an automatic and continuous inversion of the utilization. The changeover takes place when the system pressure exceeds the inversion valves calibration pressure, and therefore also in not predetermined position. At the cylinder stroke end, the overall maximum pressure valve should be adjusted on a value 30% higher than the system operating pressure.

Max. operating pressure	320 bar
Max. pressure port T	160 bar
Min. recommended pressure	15 bar
Max. flow	70 l/min
Min. flow	6 l/min
Setting ranges:	Spring 1 15 ÷ 50 bar
	Spring 2 20 ÷ 140 bar
	Spring 3 50 ÷ 320 bar
Fluid viscosity	10 ÷ 60 mm <sup>2</sup> /s
Fluid temperature	-20°C ÷ 75°C
Max. contamination level	class 10 in accordance with NAS 1638 with filter β <sub>25</sub> ≥ 75
Weight	5,4 Kg

### ORDERING CODE

- AD** Directional valve
- 5** CETOP 5/NG10
- RI** Automatic reciprocating valve hydraulically operated automatic reciprocation
- 211** Scheme
- Z** No voltage
- \*** Setting ranges:  
1 = 15 ÷ 50 bar  
2 = 20 ÷ 140 bar  
3 = 50 ÷ 320 bar
- \*\*** 00 = No variant  
V1 = Viton
- 3** Serial No.

The inverter valves pressure calibration values should be 15% lower than that of the overall maximum pressure valve, and 15% higher than the maximum operating pressure.

Note: to operate the push button emergency, a minimum pressure of 3 bar on the actuator is needed.

### HYDRAULIC SYMBOL

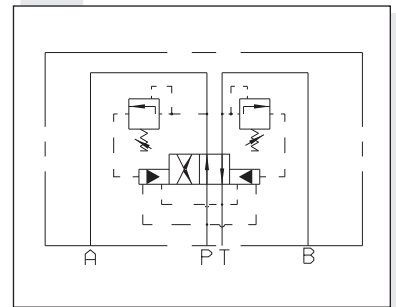

### PRESSURE DROPS

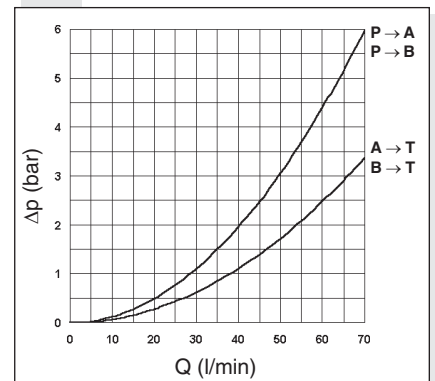

Tests carried out with mineral oil a temperature of 40°C with a viscosity of 46 mm<sup>2</sup>/s.

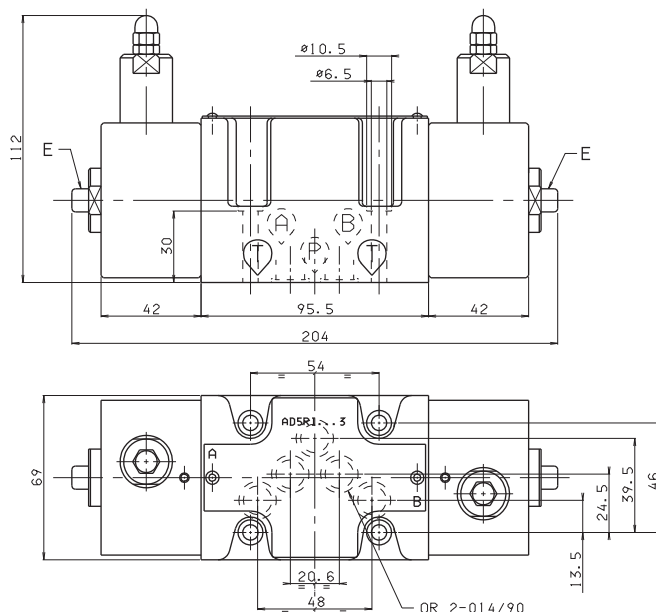

E = Manual override

Fixing screws UNI 5931 M6x40 with material specifications min. 8.8  
Tightening torque 8 Nm / 0.8 Kgm

Support plane specifications

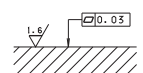



## ADPH5...

STANDARD SPOOLS FOR ADPH5	CAP. I • 51
TECH. SPECIFICATIONS ADPH5	CAP. I • 52
CETOP 2/NG04	CAP. I • 2
AD2E...	CAP. I • 4
"A09" DC COILS	CAP. I • 4
STANDARD CONNECTORS	CAP. I • 20

## ADPH5... PILOTED VALVES CETOP 5/NG10 WITH CETOP 2/NG4 PILOT VALVE

These ADPH 5 valves are used primarily for controlling the starting, stopping and direction of fluid flow. These kind of distributors are composed by a main stage crossed by the big flow from the pump (ADPH5) and by a cetop 2 pilot directional solenoid valve (AD2E) available with different mounting type .

When a short response time is requested, a special version of solenoids with high dynamics is available with the code AD2E\*\*\*\*FF2 (please, contact our technical department).

## HYDRAULIC SYMBOL

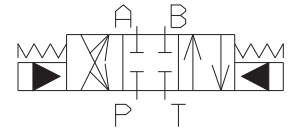

## ORDERING CODE

<b>ADPH</b>	Piloted valve <b>The pilot valves AD2E... must be ordered separately</b>
<b>5</b>	CETOP 5/NG10
<b>**</b>	Spool type (Table next page)
<b>*</b>	Mounting (Table next page) Standard orifice at port P: $\varnothing$ 1mm
<b>*</b>	Orifice type on Cetop 2 valves (Table 1) <b>0</b> = none <b>A/B/C/D/E/F/G</b> = orifice on line A <b>H/I/L/M/N/P/Q</b> = orifice on line B
<b>*</b>	Piloting and draining type (Tab.2) <b>I</b> = internal piloting internal draining <b>E</b> = internal piloting external draining <b>X</b> = external piloting internal draining (special body)
<b>00</b>	No variant
<b>1</b>	Serial No.

TAB.1 - ORIFICE ON LINE A/B

On line A	On line A	$\varnothing$ (mm)
<b>0</b>	<b>0</b>	—
<b>A</b>	<b>H</b>	0,5
<b>B</b>	<b>I</b>	0,6
<b>C</b>	<b>L</b>	0,7
<b>D</b>	<b>M</b>	0,8
<b>E</b>	<b>N</b>	0,9
<b>F</b>	<b>P</b>	1,0
<b>G</b>	<b>Q</b>	1,2

TAB.2 - PLUGS DISPOSAL

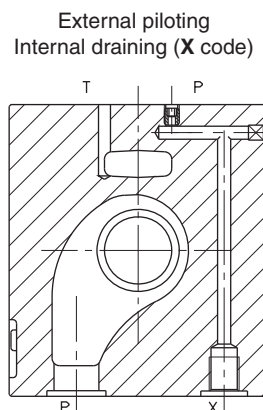
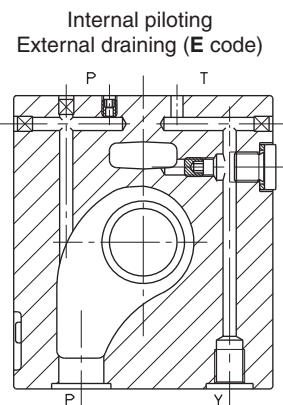
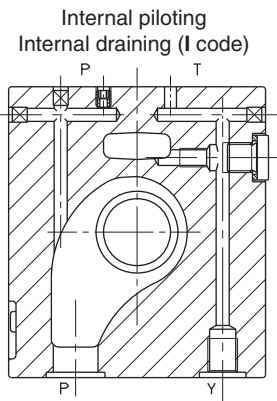

# ADPH5... PILOTED VALVES 5/NG10 WITH CETOP 2/NG4 PILOT VALVE

## HYDRAULIC SYMBOLS, SPOOLS AND MOUNTING

(\* Spools with price increasing)

1

"A" MOUNTING			
Pilot Piloted	AD.2.E.03.E... ADPH.5.**.A...		
Scheme			
Spool type		Covering	Transient position
01		+	
02		-	
03		-	
04*		-	
06		+	
15		-	
16		+	

"B" MOUNTING			
Pilot Piloted	AD.2.E.03.F... ADPH.5.**.B...		
Scheme			
Spool type		Covering	Transient position
01		+	
02		-	
03		-	
04*		-	
06		+	
15		-	
16		+	

"C" MOUNTING			
Pilot Piloted	AD.2.E.03.C... ADPH.5.**.C...		
Scheme			
Spool type		Covering	Transient position
01		+	
02		-	
03		-	
04*		-	
06		+	

### PRESSURE DROPS

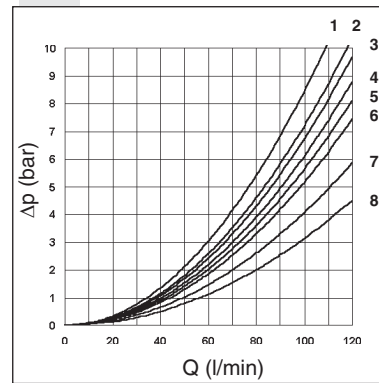

The diagram at the side shows the pressure drop curves for spools during normal usage. The used fluid is a mineral oil with a viscosity of 46 mm<sup>2</sup>/s at 40°C; the tests have been carried out at a fluid temperature of 40°C. For flow rates higher than those in the diagram, the losses will be those expressed by the following formula:

$$\Delta p1 = \Delta p \times (Q1/Q)^2$$

where  $\Delta p$  will be the value for the losses for a specific flow rate Q which can be obtained from the diagram,  $\Delta p1$  will be the value of the losses for the flow rate Q1 that is used.

Spool type	Connections				
	P→A	P→B	A→T	B→T	P→T
01	4	4	7	7	
02	6	6	8	8	7
03	3	3	8	8	
04	4	4	2	2	3
06	4	4	7	8	
15	2	2	5	5	
16	1	1	2	2	
Curve No.					

# ADPH5... PILOTED VALVES 5/NG10 WITH CETOP 2/NG4 PILOT VALVE

1

## PILOT SOLENOID CONTROL VALVE SPECIFICATIONS

Max. operating pressure: ports P/A/B	250 bar
Max. operating pressure: port T (dynamic)	70 bar
Max. piloting pressure	250 bar
Min. piloting pressure	10 bar
Max. flow	120 l/min
Switching times (*see note below)	Energizing: 20 ms De-energizing: 50 ms
Piloting oil volume for engagement	1 cm <sup>3</sup>
Hydraulic fluid	mineral oil DIN 51524
Fluid viscosity	10 ÷ 500 mm <sup>2</sup> /s
Fluid temperature	-20°C ÷ 75°C
Max. contamination level	class 10 in accordance with NAS 1638 with filter $\beta_{25} \geq 75$ plate
Mounting	
Weight ADPH5 without pilot valve	3,4 Kg
Weight ADPH5 with pilot valve with one solenoid	4,3 Kg
Weight ADPH5 with pilot valve with two solenoids	4,5 Kg

(\* All the tests have been carried out with AD2E pilot valve with variant FF, mounting type C, spool 03, flow 100 l/min, pressure 160 bar, back pressure on the T line of 2 bar and oil temperature 40°C.

## EXTERNAL BACK PRESSURE ON LINE P

(FOR SPOOL IN THE CENTRE POSITION)

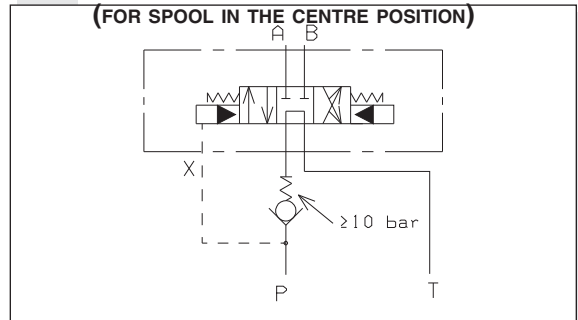

When the main spool connect P to T in the centre position, the minimum pressure of 10 bar is needed to move the main spool (see the "Specifications"); for this reason a check valve on the P line (see the drawing above) is necessary.

## OVERALL DIMENSIONS AND MOUNTING SURFACE

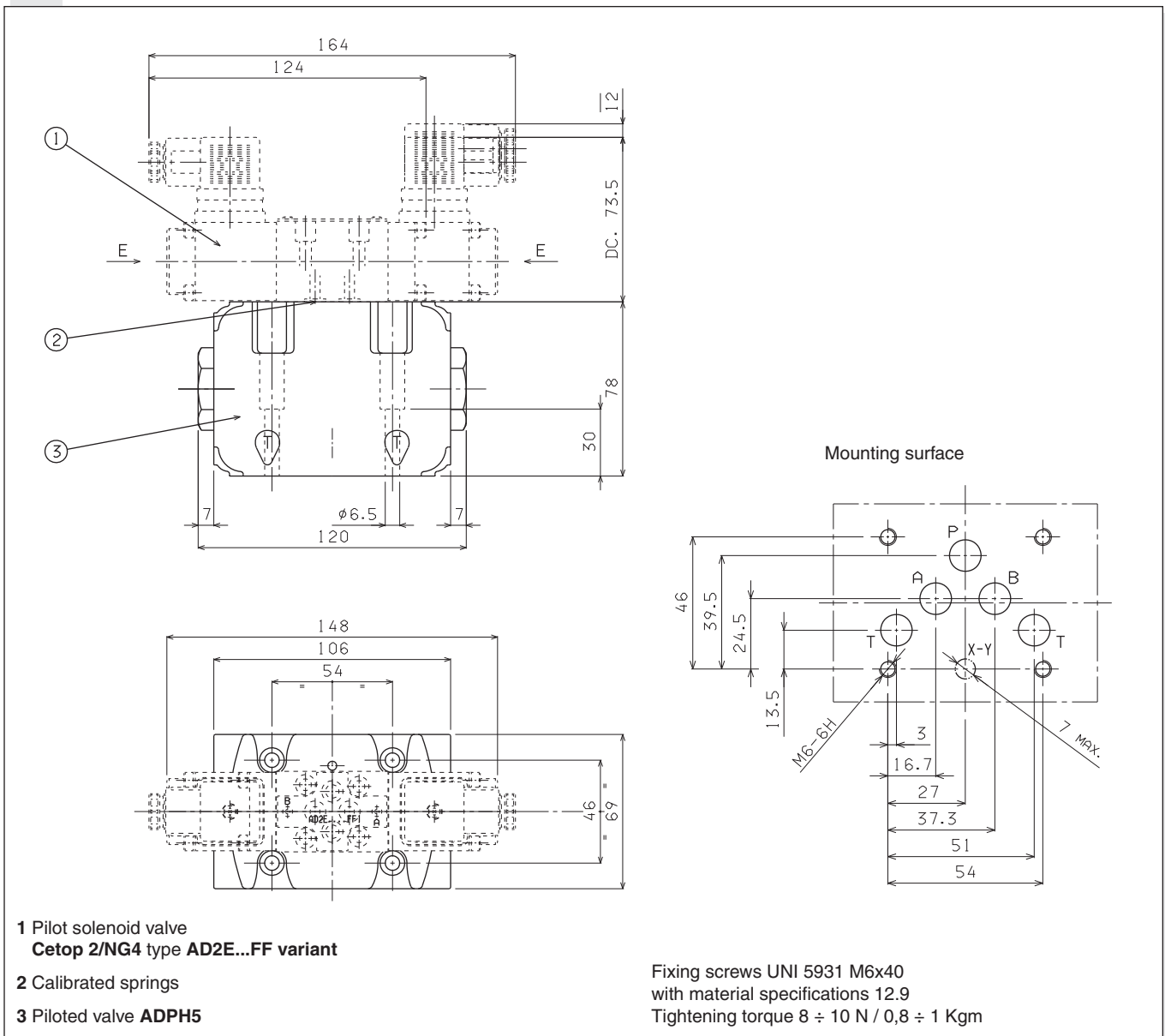

# ADH5... 4/3 AND 4/2 PILOTED VALVES CETOP 5/NG10



Type ADH.5 distributors are intended for interrupting, inserting and diverting a hydraulic system flow. Normally these distributors are composed of a main stage, crossed by circuit main flow, and of a pilot stage available in several versions.

Various types of controls are available, used either individually or in combination for, among other functions, stroke limitation and main spool movement speed control, in order to optimize the hydraulic system operation where this type of valve is employed.

In those case where normally to drain spools are used, it is necessary to remember that the minimum changeover pressure due to the opposing springs is equal to approximately 7 bar (see the operating features table on page I•46) and consequently necessary to insert a check valve in the P way (as shown above).

- Mounting surface in accordance with UNI ISO 4401 - 05 - 05 - 0 - 94 standard (ex CETOP R 35 H 4.2-4-05).
- Pilot operated spool, solenoid controller.
- Stroke control of main spool.
- Presetting for pressure reducing valve mounting.
- Presetting for single-acting throttle valve mounting.

ADH5...	
STANDARD SPOOLS FOR ADH5	CAP. I • 54
TECH. SPECIFICATIONS	CAP. I • 55
SUBPLATES BSH5...	CAP. I • 56
CMP30...	CARTRIDGE CATALOGUE
CETOP 3/NG06	CAP. I • 8
STANDARD SPOOLS FOR AD.3.E	CAP. I • 10
AD3E...	CAP. I • 11
"D15" DC COILS	CAP. I • 19
"B14" AC SOLENOIDS	CAP. I • 19
STANDARD CONNECTORS	CAP. I • 20

### ORDERING CODE

<b>ADH</b>	Piloted valve (Pilot valve and any mounting valves should be ordered separately)
<b>5</b>	CETOP 5/NG10
<b>*</b>	Mounting type (Table next page)
<b>**</b>	Spool type (Table next page)
<b>*</b>	Piloting and draining <b>I</b> = X internal / Y internal <b>IE</b> = X internal / Y external <b>EI</b> = X external / Y internal <b>E</b> = X external / Y external (see diagram at side)
<b>**</b>	<b>00</b> = No variant <b>LC</b> = Main spool stroke limiter
<b>1</b>	Serial No.

### EXTERNAL CHECK ON P

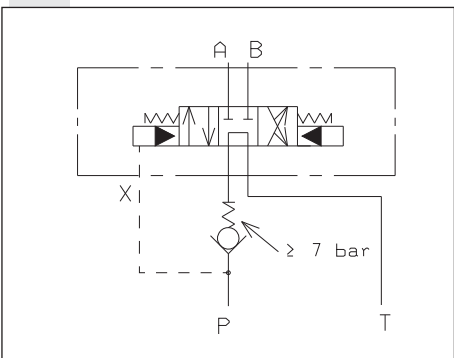

### PLUGS ARRANGEMENT FOR THE PILOT AND DRAIN LINES

Plugs type used: M5x6 both for pilot and drain

	<p><b>ADH5...I</b> X internal piloting Y internal draining</p>
	<p><b>ADH5...IE</b> X internal piloting Y external draining</p>
	<p><b>ADH5...EI</b> X external piloting Y internal draining</p>
	<p><b>ADH5...E</b> X external piloting Y external draining</p>

# ADH5... 4/3 AND 4/2 PILOTED VALVES CETOP 5/NG10

1

## PRESSURE DROPS

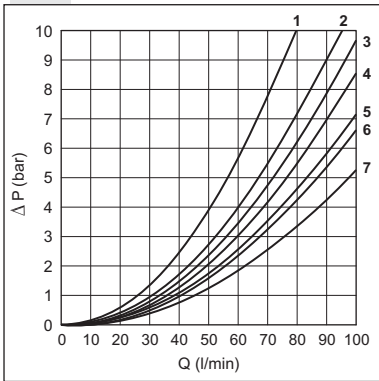

The diagram on the side shows the pressure drops in relation to spools adopted for normal usage (see table).

Tests carried out at a constant temperature of 40°C.

The fluid used was a mineral based oil with a viscosity of 46 mm<sup>2</sup>/s at 40°C.

Spool type	Connections				
	P→A	P→B	A→T	B→T	P→T
01	3	3	5	5	
02	3	3	6	6	3
03	3	3	6	6	
04	2	2	5	5	1
05	3	3	5	5	
06-66	3	3	6	6	
07		1	6		
10	3	3	5	5	
11	4		5		
22		4	5		
14-28	3	3	7	7	2
15	3	3	4	5	
16	3	3	4	5	
17	3	3			
	Curve No.				

## SPOOLS AND MOUNTING TYPE

(\* Spools with price increasing)

Pilot Piloted	C mounting AD.3.E.03.C... ADH.5.C.**..	A mounting AD.3.E.03.E... ADH.5.A.**..	B mounting AD.3.E.03.F... ADH.5.B.**..	P mounting AD3E16E/AD3E16F ADH.5.P.**..
Scheme				
Spool type				
01				
02				
03				
04*				
05				
66				
06				
07*				
10*				
11*				
22*				
14*				
28*				
15				
16				
17				



# ADH5... 4/3 AND 4/2 PILOTED VALVES CETOP 5/NG10

## PILOT SOLENOID CONTROL VALVE SPECIFICATIONS

FOR DIFFERENT CONTROLS, PLEASE CONTACT OUR TECHNICAL DEPARTMENT

Max. operating pressure ports P/A/B	320 bar
Max. operating pressure port T (int. drainage)	160 bar
Max. pressure on T (ext. drainage)	250 bar
Max. piloting pressure	250 bar
Min. piloting pressure	7 bar
Max. flow	100 l/min
Piloting oil volume engagement 3 position valves	0,8 cm <sup>3</sup>
Piloting oil volume engagement 2 position valves	1,6 cm <sup>3</sup>
Hydraulic fluid	mineral oil DIN 51524
Fluid viscosity	10 ÷ 500 mm <sup>2</sup> /s
Fluid temperature	-20°C ÷ 75°C
Max. contamination level	class 10 in accordance with NAS 1638 with filter $\beta_{25} \geq 75$
Weight ADH5 without pilot valve	2,7 Kg
Weight ADH5 with pilot valve with 1 AC solenoid	4 Kg
Weight ADH5 with pilot valve with 1 DC solenoid	4,2 Kg
Weight ADH5 with pilot valve with 2 AC solenoids	4,3 Kg
Weight ADH5 with pilot valve with 2 DC solenoids	4,7 Kg

## SWITCHING TIMES PILOTED VALVE

OPERATING PRESSURE (bar)	CURRENT	ENERGIZING centre-extern (ms)	DE-ENERGIZING extern-centre (ms)
50	ALTERNATING	30	50
100		25	
200		20	
50	DIRECT	40	60
100		35	
200		30	

3 position valve. The values are indicative and depend on the hydraulic circuit, the fluid used and the variations in pressure, flow rate and temperature.

## OVERALL DIMENSIONS

## CETOP 5 MOUNTING SURFACE

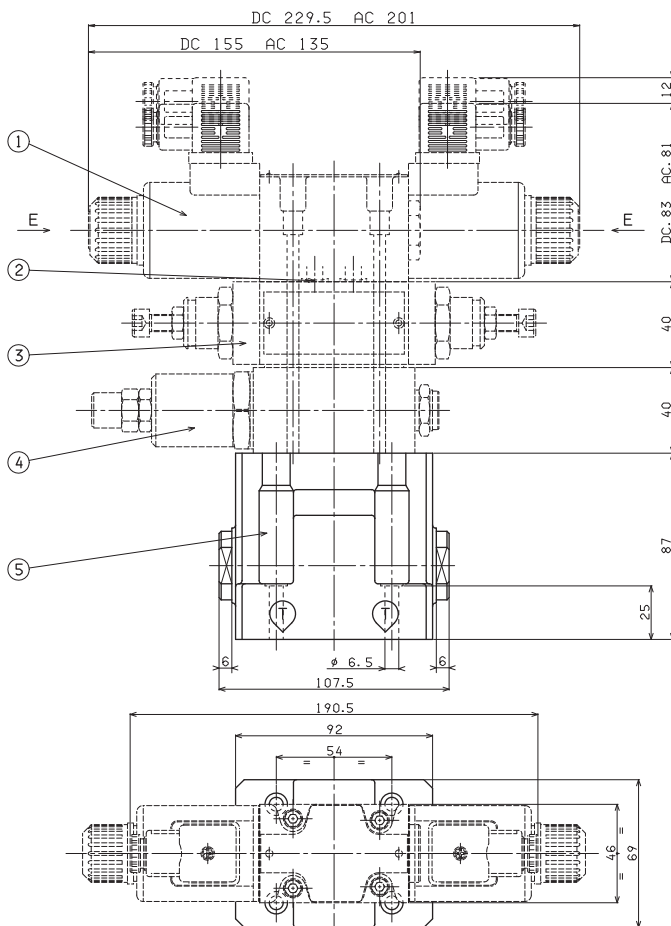

- 1 Piloted solenoid valve type **AD3E... CETOP 3/NG6**
- 2 Calibrated diaphragms for **AD3E...**
- 3 Flow regulation valve type **AM3QF..C**
- 4 Pressure reduction valve type **AM3RD..C**
- 5 Main valve type **ADH5..E**

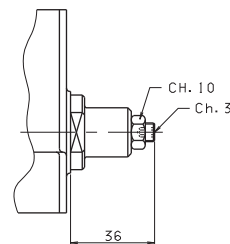
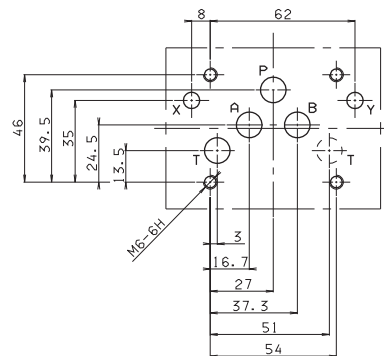

## SPOOL STROKE ADJUSTMENT

Fixing screws UNI 5931 M6x35 with material specifications 12.9  
Tightening torque 8 N / 0,8 Kgm

# BSH5... SUBPLATES MOUNTING FOR ADH5 TYPE PILOTED VALVES CETOP 5/NG10

1

## BSH513 WITH P, T AND A, B REAR 3/4" BSP, X AND Y CLEARANCE HOLES

- BSH** Single plate for piloted valve
- 5** CETOP 5/NG10
- 13** 3/4" BSP rear connectors
- 00** No variant
- 1** Serial No.

Weight: 3,8 Kg  
Fixing screws M6x50 UNI 5931

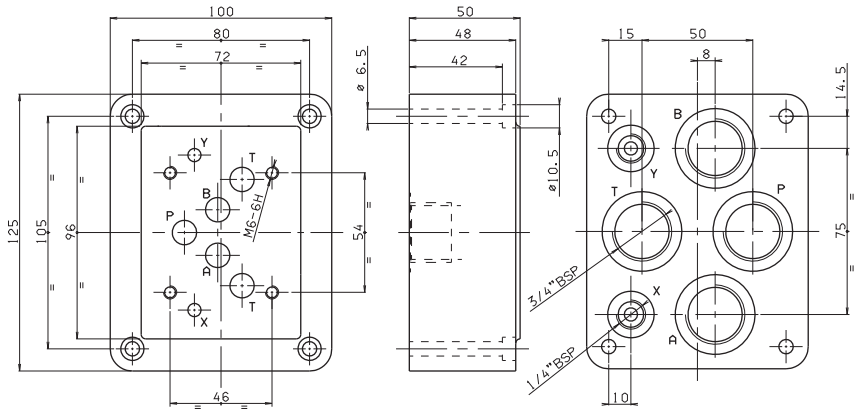

## BSH517 WITH P AND T REAR AND A, B SIDE 3/4" BSP, X AND Y CLEARANCE HOLES

- BSH** Single plate for piloted valve
- 5** CETOP 5/NG10
- 17** 3/4" BSP rear and side connectors
- 00** No variant
- 1** Serial No.

Weight: 3,9 Kg  
Fixing screws M6x50 UNI 5931

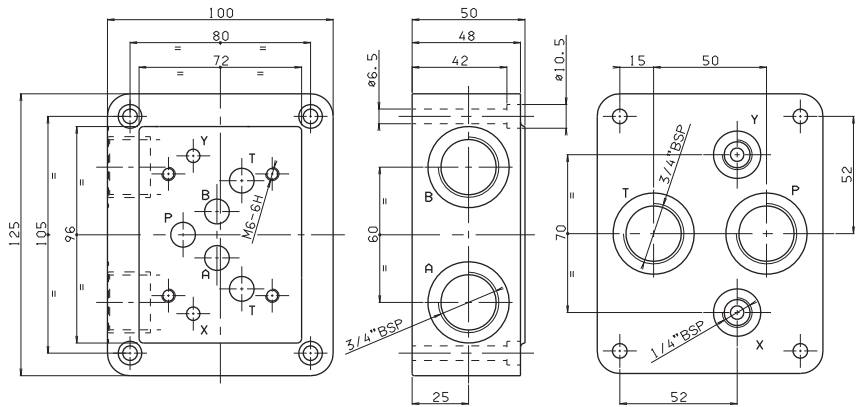

## BSH531 WITH P AND T REAR, A AND B SIDE 3/4" BSP, X AND Y CLEARANCE HOLES WITH MAXIMUM PRESSURE VALVE

- BSH** Single plate for piloted valve
- 5** CETOP 5/NG10
- 31** 3/4" BSP rear and side connectors
- \*** **M** = Plastic knob  
**C** = Grub screw
- \*** Setting ranges  
**1** = Max 50 bar  
**2** = Max 140 bar  
**3** = Max 320 bar
- \*\*** **00** = No variant  
**V1** = Viton
- 2** Serial No.

Weight: 5,5 Kg  
Fixing screws M6x75 UNI 5931

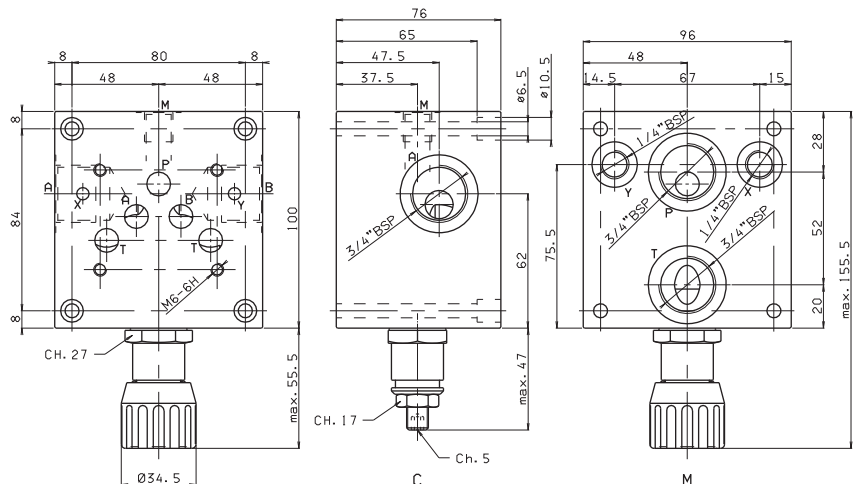

• For the minimum permissible setting pressure depending on the spring, see minimum setting curve pressure CMP30

# ADH7... 4/3 AND 4/2 PILOTED VALVES CETOP 7/NG16



ADH7...	
STANDARD SPOOLS FOR ADH7	CAP. I • 58
TECH. SPECIFICATIONS	CAP. I • 59
SUBPLATES BSH7...	CAP. I • 60
CETOP 3/NG06	CAP. I • 8
STANDARD SPOOLS FOR AD3E	CAP. I • 10
AD3E...	CAP. I • 11
ADC3...	CAP. I • 5
"A09" DC COILS	CAP. I • 7
"D15" DC COILS	CAP. I • 19
"B14" AC SOLENOIDS	CAP. I • 19
STANDARD CONNECTORS	CAP. I • 20

### ORDERING CODE

<b>ADH</b>	Piloted valve - <b>Pilot valves and any modulating valves should be ordered separately</b>
<b>7</b>	CETOP 7/NG16
<b>*</b>	Mounting type (see next page)
<b>**</b>	Spool type (see next page)
<b>*</b>	Piloting and draining <b>I</b> = X internal / Y internal <b>IE</b> = X internal / Y external <b>EI</b> = X external / Y internal <b>E</b> = X external / Y external (see Tab.1 at side)
<b>R</b>	Check valve incorporated at port P (Tab. 2) Only for <b>I</b> and <b>IE</b> versions (omit if not required)
<b>**</b>	<b>00</b> = No variant <b>LC</b> = Main spool stroke limiter
<b>2</b>	Serial No.

### TAB. 2 - INTERNAL CHECK ON P

#### ADH7\*\*\*\*R\*\*2 VERSION

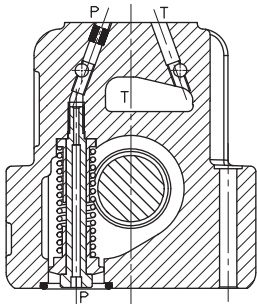

• For the spools 02-04-14-28 the piloting is normally external; the internal piloting is possible only with the internal check valve (R).

Type ADH.7 distributors are intended for interrupting, inserting and diverting a hydraulic system flow. Normally these distributors are composed of a main stage, crossed by the circuit main flow, and of a pilot stage available in several versions.

Various types of controls are available, used either individually or in combination for, among other functions, stroke limitation and main spool movement speed control, in order to optimize the hydraulic system operation where this type of valve is employed.

In those cases where normally to drain spools are used, it is necessary to remember that the minimum changeover pressure due to the opposing springs is equal to approximately 5 bar (see the operating features table next pages) and it is consequently necessary to specify when ordering the check valve incorporated in the P line, if required (as shown below).

- Mounting surface in accordance with UNI ISO 4401 - 07 - 06 - 0 - 94 standard (ex CETOP R 35 H 4.2-4-07).
- Pilot operated spool, solenoid controller.
- Stroke control of main spool.
- Presetting for pressure reducing valve mounting.
- Presetting for single-acting throttle valve mounting.

### TAB. 1 - PLUGS ARRANGEMENT FOR THE PILOT AND DRAIN LINES

Plugs type used: M5x5 both for pilot and drain.

Note: standard M6x6 orifice Ø1,5 insert in the P port (Z)

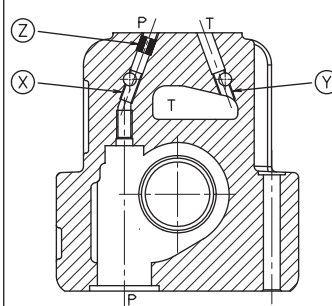

**ADH7...I**  
 X internal piloting  
 Y internal draining

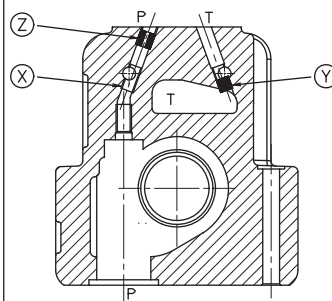
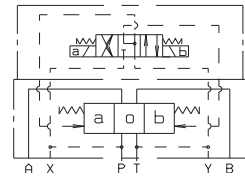

**ADH7...IE**  
 X internal piloting  
 Y external draining

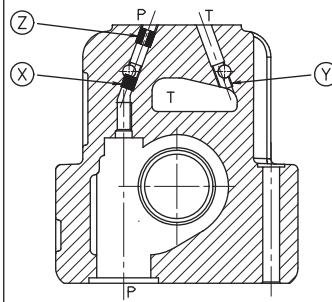
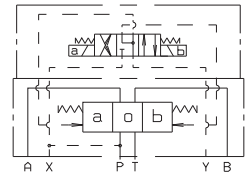

**ADH7...EI**  
 X external piloting  
 Y internal draining

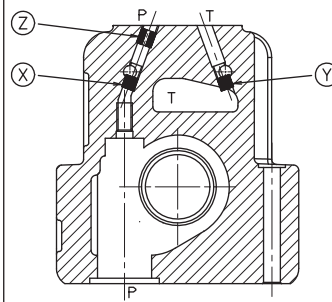
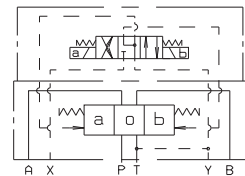

**ADH7...E**  
 X external piloting  
 Y external draining

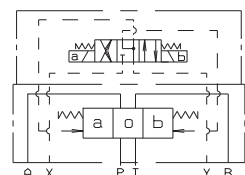

# ADH7... 4/3 AND 4/2 PILOTED VALVES CETOP 7/NG16

1

## PRESSURE DROPS

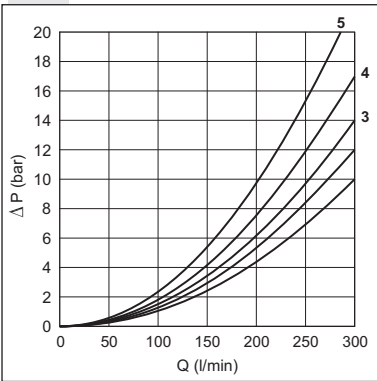

The two diagrams show the "Pressure drops" in relation to spools adopted for normal usage (see table). The fluid used was a mineral based oil with a viscosity of 46 mm<sup>2</sup>/s at 40° C.

Spool type		Connections				
		P → A	P → B	A → T	B → T	P → T
01	Energized	2	1	3	3	
02	Energized De-Energized	1	1	3	3	2
03	Energized De-Energized	2	1	3	3	
04	Energized De-Energized	2	2	4	4	5
05	Energized De-Energized	1	1	2	2	
66	Energized De-Energized	1	1	2	4	
10	Energized	2	1	3	3	
14	Energized De-Energized	1	1	3	3	4
28	Energized De-Energized	1	1	3	3	4
23	Energized	2	1	3	3	

Curve No.

## PRESSURE DROPS FOR INTERNAL CHECK ON P VERSION

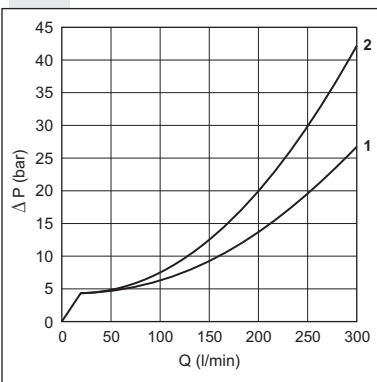

The limit of use test has been carried out with external draining and orifice Ø1,5 insert in the P port (Z). The fluid used was a mineral based oil with a viscosity of 46 mm<sup>2</sup>/s at 40° C.

## LIMIT OF USE

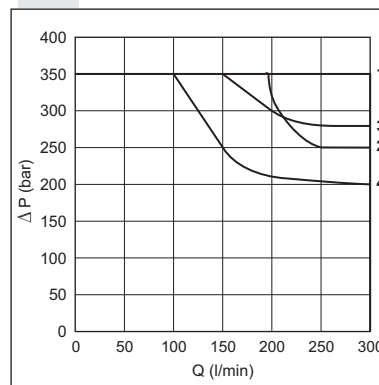

Spool type	
01	1
02	2
03	1
04	3
05	1
66	1
10	1
14	4
28	4
23	1

(\*) For the "E mounting" the locating spring works only with the steady system (\* Spools with price increasing)

## SPOOLS AND MOUNTING TYPE

	C mounting	A mounting	B mounting	E mounting (*)	P mounting
<b>Pilot Piloted</b>	AD3E03C... ADH7C...	AD3E03E... ADH7A...	AD3E03F... ADH7B...	AD3E16E... ADH7E...	AD3E16E/AD3E16F ADH7P...
<b>Scheme</b>					
<b>Spool type</b>					
01					
02					
03					
04*					
05					
66					
10*					
14*					
28*					
23*					

# ADH7... 4/3 AND 4/2 PILOTED VALVES CETOP 7/NG16

## PILOT SOLENOID CONTROL VALVE SPECIFICATIONS

FOR DIFFERENT CONTROLS, PLEASE CONTACT OUR TECHNICAL DEPARTMENT

Max. operating pressure ports P/A/B	350 bar
Max. operating pressure port T (int. drainage)	160 bar
Max. operating pressure port T (ext. drainage)	250 bar
Max. piloting pressure	210 bar
Min. piloting pressure*	12 bar
Max flow	300 l/min.
Piloting oil volume for engagement 3 position valves	4 cm <sup>3</sup>
Piloting oil volume for engagement 2 position valves	8 cm <sup>3</sup>
Hydraulic fluid	mineral oil DIN 51524
Fluid viscosity	2.8 ÷ 380 mm <sup>2</sup> /s
Fluid temperature	-20°C ÷ 70°C
Ambient temperature	-20°C ÷ 50°C
Max. contamination level	class 10 in accordance with NAS 1638 with filter $\beta_{25} \geq 75$
Weight ADH7 without pilot valve	7 Kg
Weight ADH7 with pilot valve with 1 AC solenoid	8,2 Kg
Weight ADH7 with pilot valve with 1 DC solenoid	8,4 Kg
Weight ADH7 with pilot valve with 2 AC solenoids	8,5 Kg
Weight ADH7 with pilot valve with 2 DC solenoids	9 Kg

\* For valves with internal drain (Y), tank pressure on T must be added to min. piloting pressure.

For version "R" with check valve on P, the cracking pressure of 5 bar is obtained with flow rate > 25 l/min.

### Switching time

Such values refer to a tests carried out with solenoid valve type AD3E03 with P = 100 bar pressure and Q = 100 l/min flow. Orifice  $\phi$  1.5 mm, insert on piloting port, using a mineral oil at 40°C. with 46 mm<sup>2</sup>/s viscosity.

### TEMPI DI RISPOSTA VALVOLA PILOTATA

Solenoids	ENERGIZING $\pm 10\%$ (ms)		DE-ENERGIZING $\pm 10\%$ (ms)	
	01 - 03		01 - 03	
No. Spool	01 - 03		01 - 03	
Scheme	2 positions	3 positions	2 positions	3 positions
<b>AC</b>	50	20	25	30
<b>DC</b>	70	35	40	50
Solenoids	02 - 04		02 - 04	
	02 - 04		02 - 04	
No. Spool	02	04	02 - 04	02 - 04
Scheme	2 posit.	2 posit.	3 posit.	2 positions
<b>AC</b>	35	60	30	25
<b>DC</b>	55	80	40	50

**Note:** the solenoid valve type **ADC3E...** (with A09 coil) and **AD3E...** (with D15 or B14 coils) could be used both as pilote valve, without any changement of technical features.

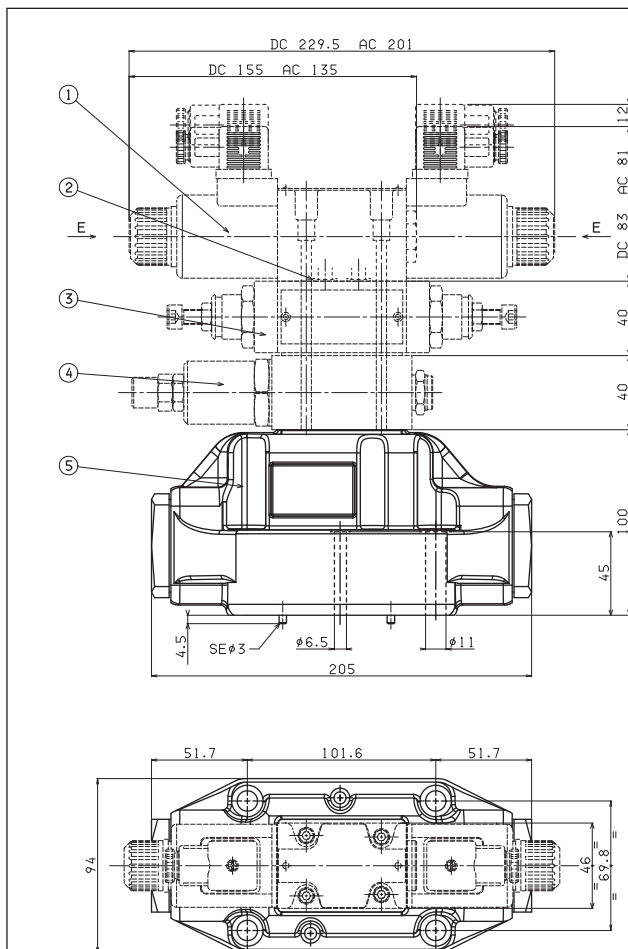

### CETOP 7 MOUNTING SURFACE

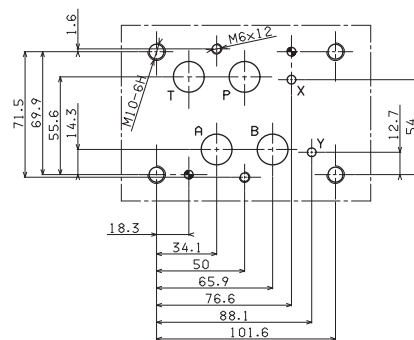

- Piloted valve fixing:  
n° 4 screws T.C.E.I. M10x60 - Tightening torque 40 Nm  
n° 2 screws T.C.E.I. M6x55 - Tightening torque 8 Nm
- Seals:  
n° 4 OR 2-118 PARKER (type 130)  
n° 2 OR 2-013 PARKER (type 2043)

### SPOOL STROKE ADJUSTMENT

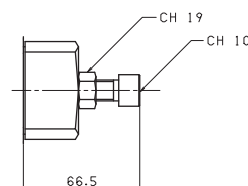

- 1 Piloted solenoid valve type **AD3E...** or **ADC3E...** CETOP 3/NG6
- 2 Calibrated diaphragms **AD3E...**
- 3 Flow regulation valve type **AM3QF.C**
- 4 Pressure reduction valve type **AM3RD..C**
- 5 Main valve type **ADH7..E**

# BSH7... SUBPLATES MOUNTING FOR ADH7 TYPE PILOTED VALVES CETOP 7/NG16

1

## BSH712 WITH P, T, AND A, B REAR 3/4" BSP

- BSH** Single plate for piloted valve
- 7** CETOP 7/NG16
- 12** 3/4" BSP rear connectors
- 00** No variant
- 1** Serial No.

Weight: 5,5 Kg

Fixing screws M8x55 UNI 5931

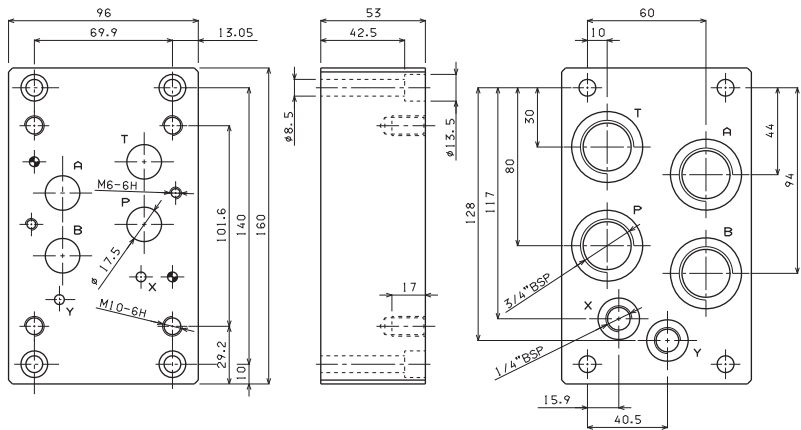

## BSH713 WITH P, T AND A, B REAR 1" BSP

- BSH** Single plate for piloted valve
- 7** CETOP 7/NG16
- 13** 1" BSP rear connectors
- 00** No variant
- 1** Serial No.

Weight: 4,7 Kg

Fixing screws M8x55 UNI 5931

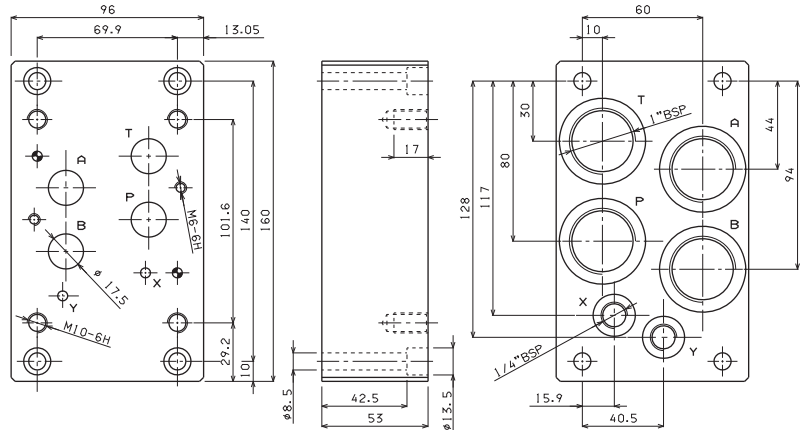

## BSH714 WITH P, T AND A, B SIDE 3/4" BSP

- BSH** Single plate for piloted valve
- 7** CETOP 7/NG16
- 14** 3/4" BSP side connectors
- 00** No variant
- 1** Serial No.

Weight: 6,3 Kg

Fixing screws M8x55 UNI 5931

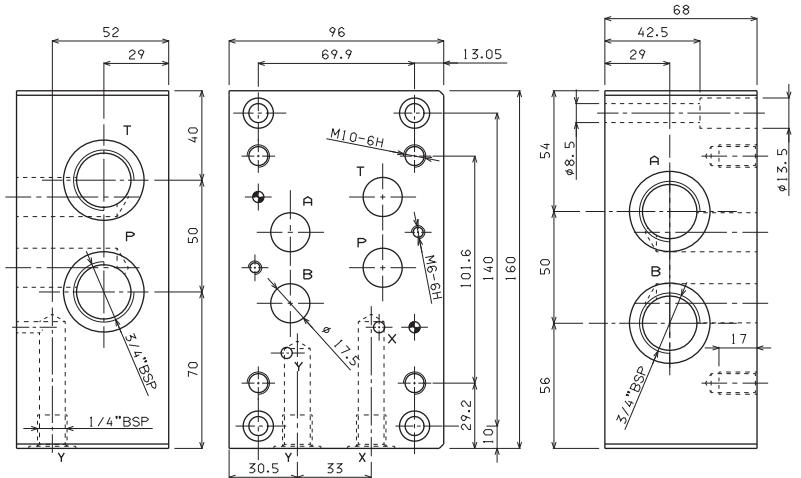

# BSH7... SUBPLATES MOUNTING FOR ADH7 TYPE PILOTED VALVES CETOP 7/NG16

1

## BSH715 WITH P, T AND A, B SIDE 1" BSP

- BSH** Single plate for piloted valve
- 7** CETOP 7/NG16
- 15** 1" BSP side connectors
- 00** No variant
- 1** Serial No.

Weight: 6,3 Kg  
Fixing screws M8x55 UNI 5931

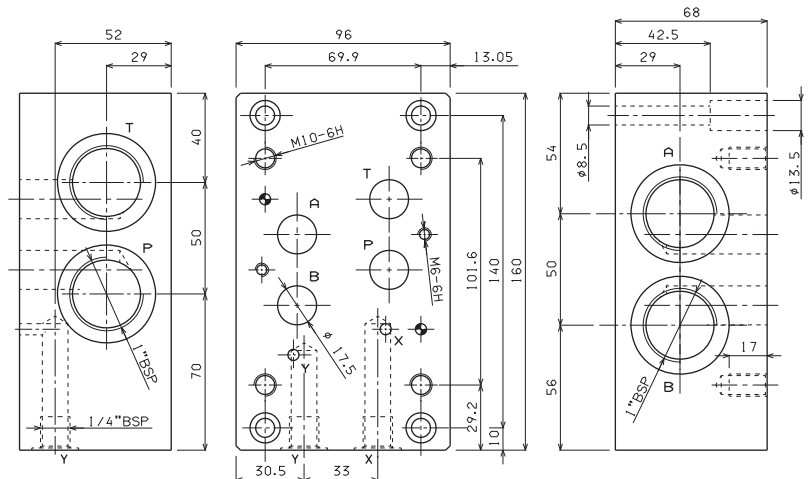

## BSH716 WITH P AND T REAR, A AND B SIDE 3/4" BSP, X AND Y REAR

- BSH** Single plate for piloted valve
- 7** CETOP 7/NG16
- 16** 3/4" BSP rear and side connectors
- 00** No variant
- 1** Serial No.

Weight: 5,1 Kg  
Fixing screws M8x50 UNI 5931

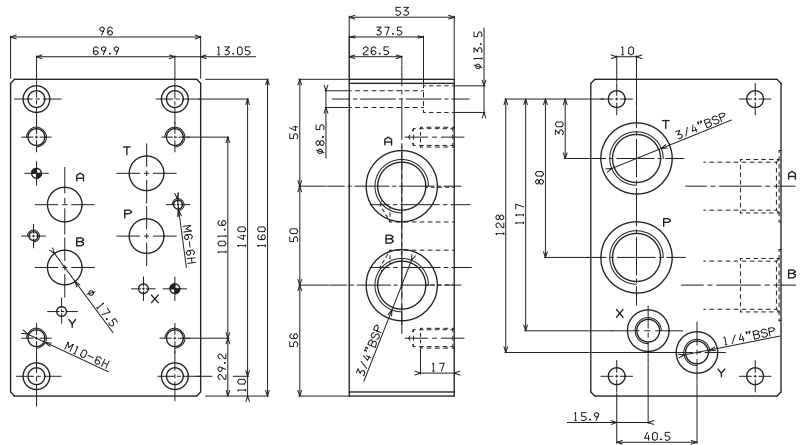

## BSH717 WITH P AND T REAR, A AND B SIDE 1" BSP, X AND Y REAR

- BSH** Single plate for piloted valve
- 7** CETOP 7/NG16
- 17** 1" BSP rear and side connectors
- 00** No variant
- 1** Serial No.

Weight: 5,3 Kg  
Fixing screws M8x55 UNI 5931

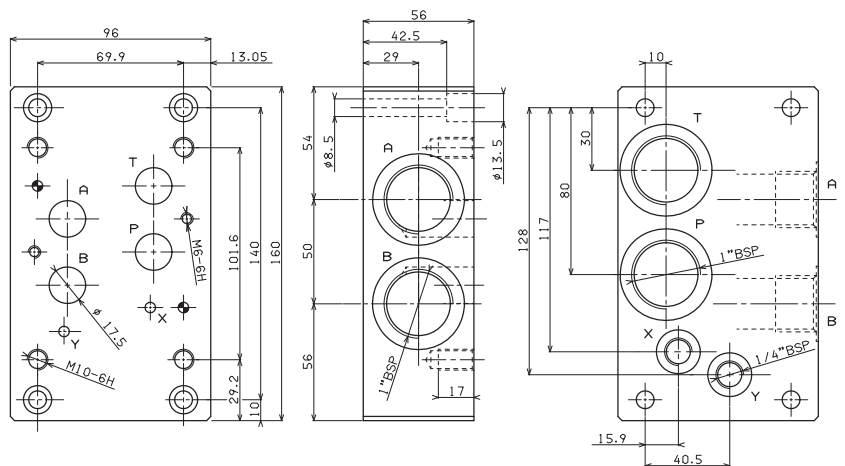



### ADH8...

STANDARD SPOOLS FOR ADH8	CAP. I • 63
TECH. SPECIFICATIONS	CAP. I • 64
BSH8...	CAP. I • 65
CETOP 3/NG06	CAP. I • 8
STANDARD SPOOLS FOR AD3E	CAP. I • 10
AD3E...	CAP. I • 11
"D15" DC COILS	CAP. I • 19
"B14" AC SOLENOIDS	CAP. I • 19
STANDARD CONNECTORS	CAP. I • 20

### ORDERING CODE

**ADH**

Piloted valve  
(Pilot valves and any modulating valves should be ordered separately)

**8**

CETOP 8/NG25

**\***

Mounting type (see next page)

**\*\***

Spool type (see next page)

**\***

Piloting and draining  
**I** = X internal / Y internal  
**IE** = X internal / Y external  
**EI** = X external / Y internal  
**E** = X external / Y external  
 (see Tab.1 at side)

**R**

Check valve incorporated at port P  
 - setting 5 bar (Tab. 2 below)  
 Only for **I**, **IE** versions  
 (Omit if not required)

**\*\***

**00** = No variant  
**LC** = Main spool stroke limiter

**2**

Serial No.

### TAB. 2 - INTERNAL CHECK ON P

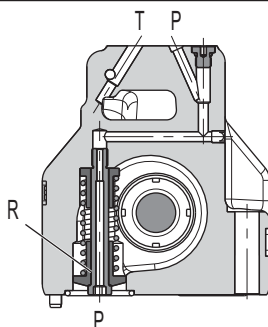

• For the spools 02-04-14-28 the piloting is normally external; the internal piloting is possible with the internal check valve (R).

## ADH8...4/3 AND 4/2 PILOTED VALVES CETOP 8/NG25

Type ADH.8 distributors are intended for interrupting, inserting and diverting a hydraulics system flow.

Normally these distributors are composed of a main stage, crossed by circuit main flow, and of a pilot stage available in several versions.

Various types of controls are available, used either individually or in combination for, among other functions, stroke limitation and main spool movement speed control, in order to optimize the hydraulic system operation where this type of valve is employed.

In those cases where normally to drain spools are used, it is necessary to remember that the minimum changeover pressure due to the opposing springs is equal to approximately 5 bar (see the operating features table next pages) and it is consequently necessary to specify when ordering the check valve incorporated in the P line, if required (as shown below).

- Mounting surface in accordance with UNI ISO 4401 - 08 - 07 - 0 - 94 standard (ex CETOP R 35 H 4.2-4-08).
- Pilot operated spool, solenoid controller.
- Stroke control of main spool.
- Presetting for pressure reducing valve mounting.
- Presetting for single-acting throttle valve mounting.

### TAB.1 - PLUGS ARRANGEMENT FOR THE PILOT AND DRAIN LINES

Plugs type used: M6x6 both for pilot X and drain Y

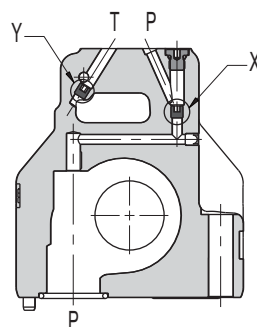

TIPO DI VALVOLA		Montaggio tappi	
		X	Y
ADH8---I	X internal piloting Y internal draining	NO	NO
ADH8---IE	X internal piloting Y external draining	NO	YES
ADH8---EI	X external piloting Y internal draining	YES	NO
ADH8---E	X external piloting Y external draining	YES	YES

### ADH8...I

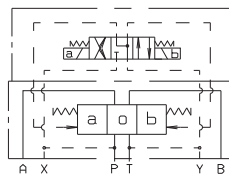

### ADH8...IE

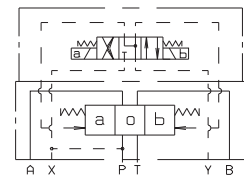

### ADH8...EI

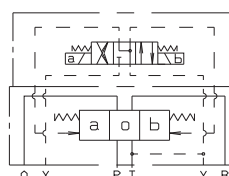

### ADH8...E

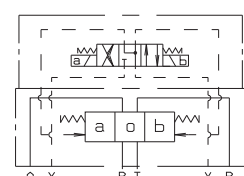



# ADH8... 4/3 AND 4/2 PILOTED VALVES CETOP 8/NG25

## PRESSURE DROPS

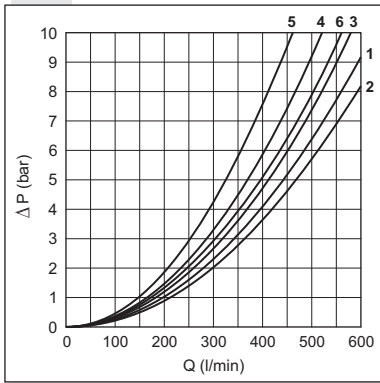

The diagram shows the pressure drops in relation to spools adopted for normal usage (see table).  
The fluid used was a mineral based oil with a viscosity of 35 mm<sup>2</sup>/s at 50° C.

Spool type		Connections				
		P → A	P → B	A → T	B → T	P → T
01	Energized	1	1	2	3	
02	Energized De-Energized	2	2	1	2	6 (1)
03	Energized De-Energized	1	1	1 4 (2)	2 4 (3)	
04	Energized De-Energized	6	6	3	4	5
05	Energized De-Energized	2 4 (2)	2 4 (3)	2	3	
66	Energized De-Energized	1	1	2	2 4	
10	Energized	1	1	2	3	
14	Energized De-Energized	6	6	3	4	5 (3)
28	Energized De-Energized	6	6	4	3	5 (2)
23	Energized De-Energized	1	2 4	2	3	
		Curve No.				

Notes: (1) A/B stopped - (2) B stopped - (3) A stopped

## SPOOLS AND MOUNTING TYPE

(\*) For the E mounting the locating spring works only with the steady system

	C mounting	A mounting	B mounting	E mounting	P mounting
Pilot Piloted	AD3E03C... ADH8C...	AD3E03E... ADH8A...	AD3E03F... ADH8B...	AD3E16E... ADH8E...	AD3E16E/AD3E16F ADH8P...
Scheme					
Spool type	A X P T Y B	A X P T Y B	A X P T Y B	A X P T Y B	A X P T Y B
01					
02					
03					
04(*) (**)					
05					
66					
10*					
14*					
28*					
23*					

(\* SPOOLS WITH PRICE INCREASING)

(\*\* THE SPOOL 04 IS AVAILABLE FOR OPERATING PRESSURES IN THE P/A/B LINES, MAX. 320 BAR)

# ADH8... 4/3 AND 4/2 PILOTED VALVES CETOP 8/NG25

## PILOT SOLENOID CONTROL VALVE SPECIFICATIONS

FOR DIFFERENT CONTROLS, PLEASE CONTACT OUR TECHNICAL DEPARTMENT

1

Max. operating pressure ports P/A/B	420 bar
The spool 04 is available for operating pressures in the P/A/B lines	max. 320 bar
Max. operating pressure port T (int. drainage)	160 bar
Max. operating pressure port T (ext. drainage)	250 bar
Max. piloting pressure	350 bar
Max. piloting pressure with main spool stroke limiter (LC variant)	250 bar
Min. piloting pressure*	5 bar
Max. flow with 04-14-28 spools	500 l/min a 210 bar 450 l/min a 320 bar
Max. flow with all other spools	600 l/min a 210 bar 500 l/min a 320 bar
Piloting oil volume for engagement 3 position valves	11.1 cm <sup>3</sup>
Piloting oil volume for engagement 2 position valves	22.12 cm <sup>3</sup>
Hydraulic fluid	mineral oil DIN 51524
Fluid viscosity	2.8 ÷ 380 mm <sup>2</sup> /s
Fluid temperature	-20°C ÷ 70°C
Ambient temperature	-20°C ÷ 50°C
Max. contamination level	class 10 in accordance with NAS 1638 with filter $\beta_{25} \geq 75$
Weight ADH8 without pilot valve	13,1 Kg
Weight ADH8 with pilot valve with 1 AC solenoid	14,3 Kg
Weight ADH8 with pilot valve with 1 DC solenoid	14,5 Kg
Weight ADH8 with pilot valve with 2 AC solenoids	14,6 Kg
Weight ADH8 with pilot valve with 2 DC solenoids	15,1 Kg

\* For valves with internal drain (Y), tank pressure on T must be added to min. piloting pressure.  
Min. piloting pressure is 5 bar with low flow rate, but it is up to 12 bar with higher flow rate.

For version "R" with check valve on P, the cracking pressure of 5 bar is obtained with flow rate > 25 l/min.

### Switching time

Such values refer to a solenoid valve with P = 100 bar pressure using a mineral oil at 50°C with 36 mm<sup>2</sup>/sec viscosity PA and BT connections.

### SWITCHING TIMES PILOTED VALVE

Solenoids	ENERGIZING ±10% (ms)		DE-ENERGIZING ±10% (ms)	
	2 posit.	3 posit.	2 posit.	3 posit.
AC	60	45	90	60
DC	75	55	90	60

### OVERALL DIMENSIONS

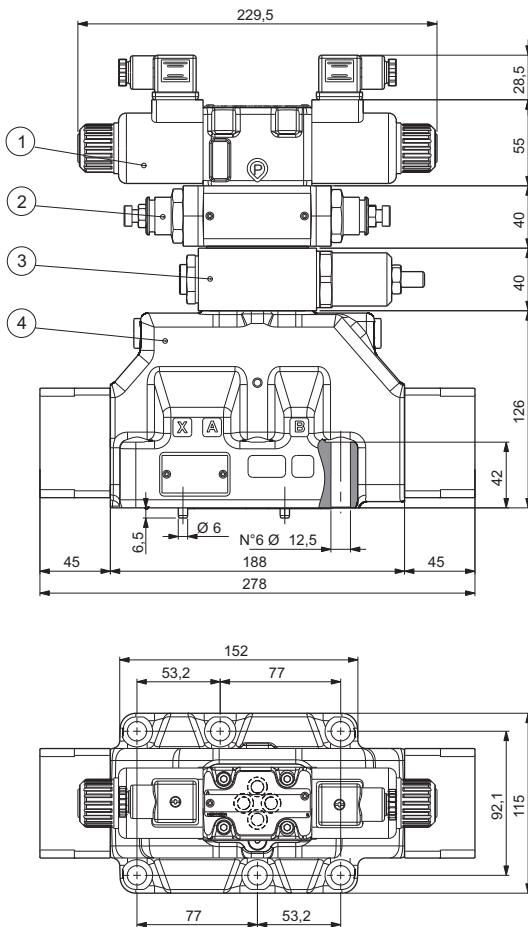

- 1 Piloted solenoid valve type **AD3E (CETOP3 NG6)**
- 2 Flow regulation valve type **AM3QF..C**
- 3 Pressure reduction valve type **AM3RD..C**
- 4 Main valve type **ADH8\***

\* The piloted valve is provided with a calibrated screw M6 with hole  $\phi 1.5$ , already mounted on the port "P".

### CETOP 8 MOUNTING SURFACE

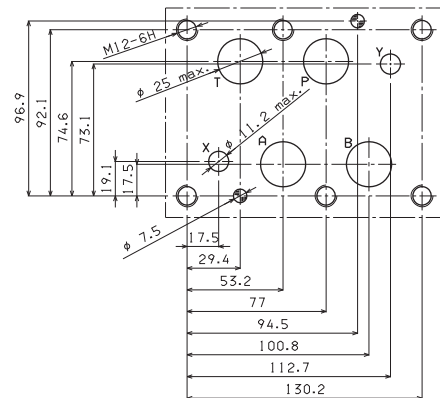

- Piloted valve fixing: n° 6 screws T.C.E.I. M12x60
- Tightening torque: 115 Nm with screw Cl. 12.9\*\*  
69 Nm with screw Cl. 8.8

\*\* Recommended for applications over 350 bar

- Seals: n°4 OR2-123/3118 type (29.82x2.62) - 90 Shore  
n°2 OR2-117/3081 type (20.24x2.62) - 90 Shore

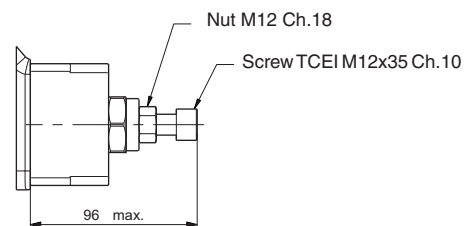

### SPOOL STROKE ADJUSTMENT (LC variant)

# BSH8... SUBPLATES MOUNTING FOR ADH8 TYPE PILOTED VALVES CETOP 8/NG25

1

## BSH813 WITH P, T AND A, B REAR 1" BSP

- BSH** Single plate for piloted valve
- 8** CETOP 8/NG25
- 13** 1" BSP rear connectors
- 00** No variant
- 1** Serial No.

Weight: 6,3 Kg - Fixing screws M10x60 UNI 5931

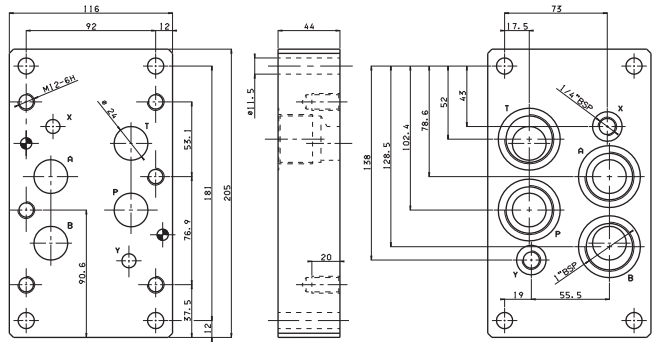

## BSH813\* WITH P, T AND A, B REAR 1"1/4 BSP OR 1" 1/2 BSP

- BSH** Single plate for piloted valve
- 8** CETOP 8/NG25
- 13\*** A = 1"1/4 BSP rear connectors  
B = 1"1/2 BSP rear connectors
- 00** No variant
- 1** Serial No.

Weight: 21,7 Kg (BSH.8.13A) - Weight: 21,2 Kg (BSH.8.13B)  
Fixing screws M12x100 UNI 5931

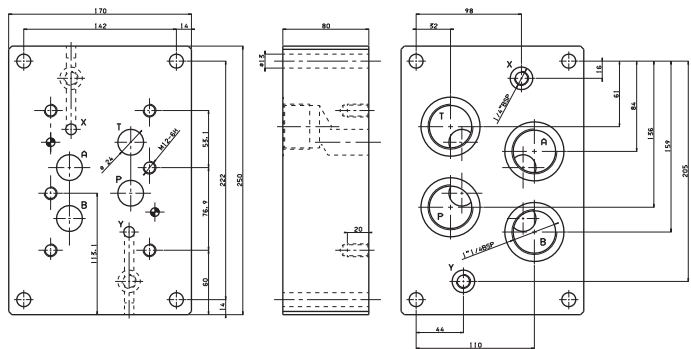

## BSH815 WITH T, P AND A, B SIDE 1" BSP

- BSH** Single plate for piloted valve
- 8** CETOP 8/NG25
- 15** 1" BSP side connectors
- 00** No variant
- 1** Serial No.

Weight: 8,2 Kg  
Fixing screws M10x75 UNI 5931

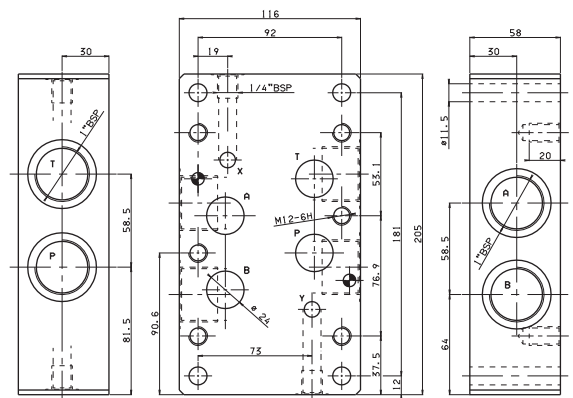

## BSH817 WITH P AND T REAR, A AND B SIDE 1" BSP, X AND Y REAR

- BSH** Single plate for piloted valve
- 8** CETOP 8/NG25
- 17** 1" BSP rear and side connectors
- 00** No variant
- 1** Serial No.

Weight: 8,3 Kg - Fixing screws M10x75 UNI 5931

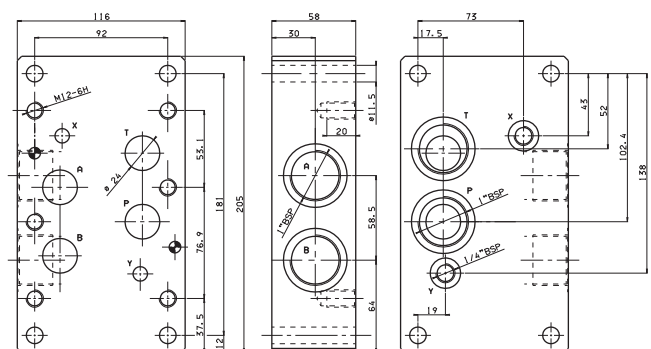



## CDL046... STACKABLE CIRCUIT SELECTOR VALVES

The stackable circuit selector valves, type CDL.04.6, allows one single drive of 5 users with 4 elements connected in series.

As they are moved from high performances solenoids they don't need the external drainage.

Additionally, beyond having a reduced and compact dimensions, they can manage high hydraulic powers with a minimal pressure drop. The body valve is white zinc plated.

Max. pressure	250 bar
Max. flow	20 l/min
Overlap	positive
Hydraulic fluids	Mineral oils DIN 51524
Fluid viscosity	10 ÷ 500 mm <sup>2</sup> /s
Fluid temperature	-25°C ÷ 75°C
Ambient temperature	-25°C ÷ 60°C
Max. contamination level	class 10 in accordance NAS with 1638 with filter $\beta_{25} \geq 75$
Weight	see "Overall dimension"

<b>CDL046...</b>	
"A09" DC Coils	CAP. I • 73
CONNECTORS STANDARD	CAP. I • 20

### ORDERING CODE

<b>CDL</b>	Stackable circuit selector valve
<b>04</b>	Size NG04
<b>6</b>	No. of way (single element)
<b>W</b>	Threaded connectors 1/4" BSP
<b>I</b>	Internal drainage
<b>*</b>	No. of elements: 1 / 2 / 3 / 4
<b>*</b>	Voltage (Tab. 1)
<b>**</b>	Variants (Tab. 2)
<b>1</b>	Serial No.

**TAB.1 - A09 (27 W) COIL**

DC VOLTAGE **	
<b>L</b>	12V
<b>4</b>	14V
<b>M</b>	24V
<b>N</b>	48V*
<b>P</b>	110V*
<b>Z</b>	102V*
<b>X</b>	205V*
<b>W</b>	Without DC coil

115Vac/50Hz  
120Vac/60Hz  
with rectifier

230Vac/50Hz  
240Vac/60Hz  
with rectifier

Voltage codes are not stamped on the plate, they are readable on the coils.

\* Special voltage  
\*\* Technical data see page CAP. I • 73

- The AMP Junior coil, the Deutsch coil with bidirectional diode and the coil with flying leads (with or without diode) coils are available in 12V or 24V DC voltage only.

**TAB. 2 - VARIANTS**

VARIANT	CODE
No variant (without connectors)	S1(*)
Viton	SV(*)
Rotary emergency button	P2(*)(**)
Emergency button	ES(*)
AMP Junior connection	AJ(*)
Bobina con fili (250 mm)	FL
with flying leads (130 mm) and integr. diode	LD
Deutsch connection with bidir. diode	CX

Other variants available on request.

(\*) Coils with Hirschmann and AMP Junior connection supplied without connectors. The connectors can be ordered separately, CAP. I • 20

(\*\*) P2 Emergency tightening torque **max. 6÷9 Nm / 0.6 ÷ 0.9 Kgm** with CH n. 22

### HYDRAULIC SYMBOLS

#### SINGLE ELEMENT

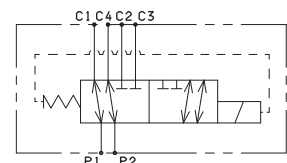

#### MULTI STATION CONNECTION

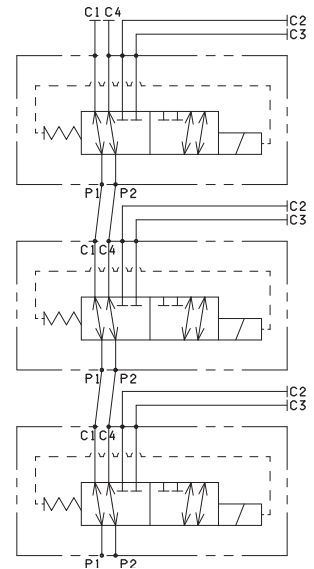

### PRESSURE DROPS

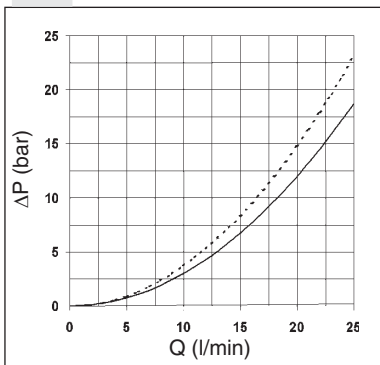

— P1 → C1  
— P1 → C2  
- - - P2 → C3  
- - - P2 → C4

### LIMITS OF USE

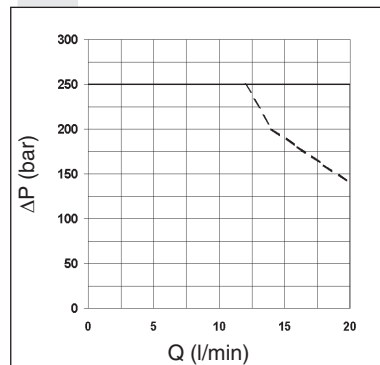

— Energizing  
- - - De-energizing

The tests have been carried out with solenoids at operating temperature and a voltage 10% less than rated voltage with a fluid temperature of 50°C. The fluid used was a mineral oil with a viscosity of 46 mm<sup>2</sup>/s at 40 degrees C.

# CDL046... STACKABLE CIRCUIT SELECTOR VALVES

## OVERALL DIMENSIONS

1

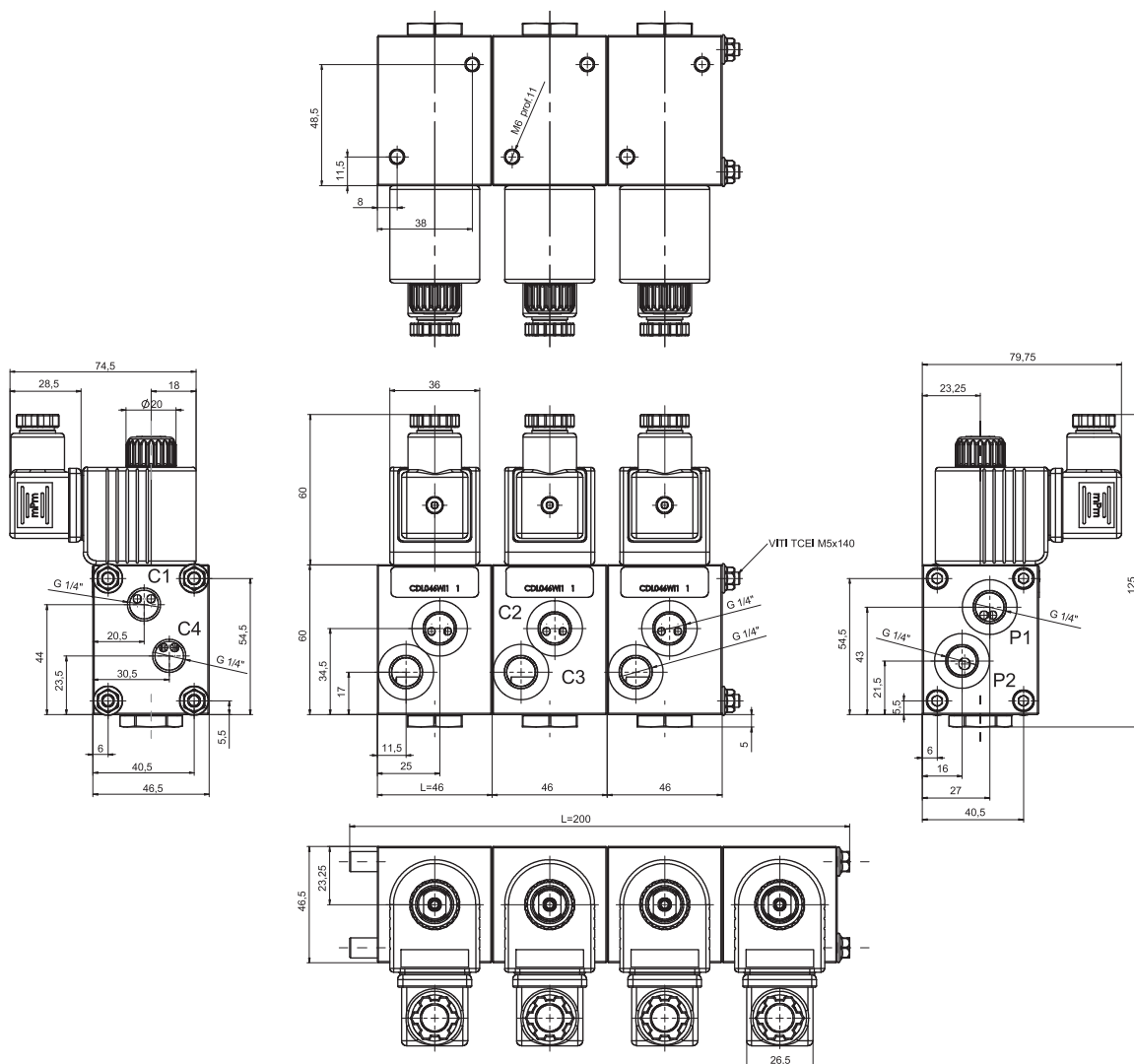

Tighten the screws to a torque of 5 Nm (0.5 Kgm)  
Fixing screws with material specifications min. 8.8

No. of elements	No. of way	L (Length)	Weight (Kg)	Fixing screws	Kit spare part code* (rods and studs)
1	06	46	1.05	—	—
2	08	100	2.20	TCEI M5x95	V89.54.0020
3	10	145	3.30	TCEI M5x140	V89.54.0021
4	12	200	4.45	TCEI M5x194 (special rods)	V89.54.0022

(\*) For multiple composition rods and studs are available.

Support plane specifications

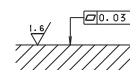



### CDL066...

"40W" DC COILS CAP. I • 74

CONNECTORS STANDARD CAP. I • 20

### ORDERING CODE

### ORDERING CODE

<b>CDL</b>	Stackable circuit selector valve
<b>06</b>	Size NG06
<b>6</b>	No. of way (single element)
<b>W</b>	Threaded connectors 3/8" BSP
<b>I</b>	Internal drainage
<b>*</b>	No. of elements: 1 / 2 / 3 / 4 / 5
<b>*</b>	Voltage (Tab. 1)
<b>**</b>	Variants (Tab. 2)
<b>1</b>	Serial No.

## CDL066... STACKABLE CIRCUIT SELECTOR VALVES

The stackable circuit selector valves, type CDL.06.6, allows one single drive of 6 users with 5 elements connected in series.

As they are moved from high performances solenoids they don't need the external drainage.

This valves can manage high hydraulic powers with a minimal pressure drop.

Max. pressure	250 bar
Max. flow	50 l/min
Overlap	negative
Hydraulic fluids	Mineral oils DIN 51524
Fluid viscosity	10 ÷ 500 mm <sup>2</sup> /s
Fluid temperature	-25°C ÷ 75°C
Ambient temperature	-25°C ÷ 60°C
Max. contamination level	class 10 in accordance NAS with 1638 with filter $\beta_{25} \geq 75$
Weight	see "Overall dimension"

### TAB.1 - 40W COIL

#### DC VOLTAGE

<b>L</b>	12V
<b>M</b>	24V
<b>W</b>	Without DC coil

Voltage codes are not stamped on the plate, their are readable on the coils.

### TAB.2 - VARIANTS

No variant (without connectors)	S1(*)
Viton	SV(*)
Emergency button	ES(*)
Rotary emergency button	P2(*)
Raccordements Deutsch DT04-2P	CZ

Other variants available on request.

(\*) Coils with Hirschmann connection supplied without connectors. The connectors can be ordered separately, CAP. I • 20.

### HYDRAULIC SYMBOLS

#### SINGLE ELEMENT

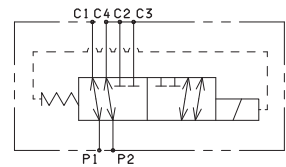

#### MULTISTATION CONNECTION

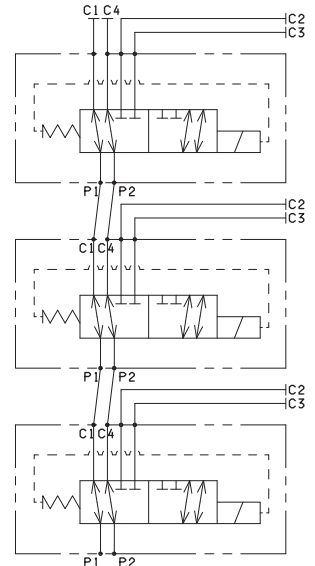

### PRESSURE DROPS

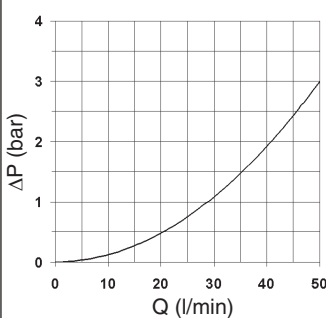

— P1 → C1, P1 → C2,  
P2 → C3 e P2 → C4

The fluid used is a mineral oil with a viscosity of 46 mm<sup>2</sup>/s at 40°C; the tests have been carried out at a fluid temperature of 40°C.

### OVERALL DIMENSIONS

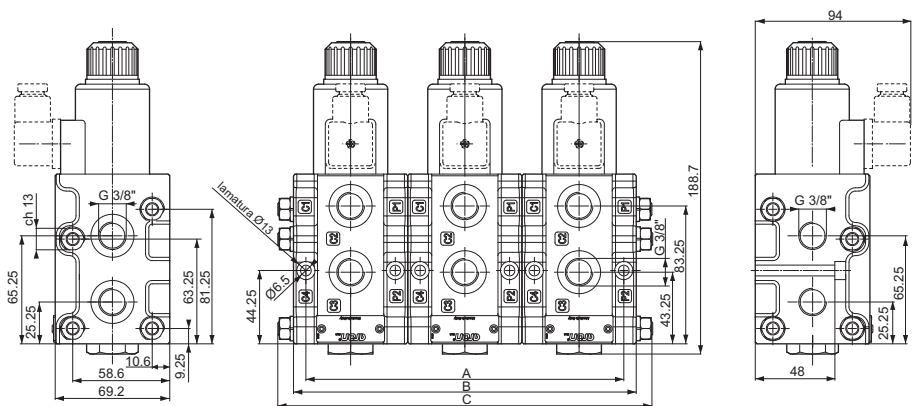

Fixing screws UNI 5931 M6x60  
with material specifications min. 8.8  
Tightening torque for studs 8 Nm / 0.8 Kgm  
Tightening torque for rods 20 Nm / 2 Kgm

(\*) For multiple composition rods and studs are available.



## ADL066... FLOW DIVERSION VALVES

The 6 way flow diversion valves are special solenoid valves which allow the simultaneous connection of two systems.

In order to obtain valve's working at pressure of 250 bar up to 320 bar (external drainage) the G 1/8" BSP plug must be removed to Y connector.

Max. pressure (without drainage, Y plugged)	250 bar
Max. pressure (external drainage)	320 bar
Max. flow	40 l/min
Overlap	negative
Fluid viscosity	10 ÷ 500 mm <sup>2</sup> /s
Fluid temperature	-25°C ÷ 75°C
Ambient temperature	-25°C ÷ 60°C
Max. contamination level	class 10 in accordance with NAS 1638 with filter β <sub>25</sub> > 75
Weight	2,4 Kg

<b>ADL066...</b>	
"D15" DC Coils	CAP. I • 73
STANDARD CONNECTORS	CAP. I • 20

### ORDERING CODE

<b>ADL06</b>	Flow diversion valves NG6
<b>6</b>	No. of way
<b>W</b>	Threaded connectors 3/8" BSP
<b>I</b>	Drainage plugged
<b>*</b>	Voltage (see table 1)
<b>**</b>	Variants (see table 2)
<b>3</b>	Serial No.

### TAB.2 - VOLTAGE

#### D15 COIL (30W) \*\*

<b>L</b>	12V	
<b>M</b>	24V	
<b>V</b>	28V*	115Vac/50Hz 120Vac/60Hz with rectifier
<b>N</b>	48V*	
<b>Z</b>	102V*	
<b>P</b>	110V*	230Vac/50Hz 240Vac/60Hz with rectifier
<b>X</b>	205V*	
<b>W</b>	Without DC coils and connectors	

Voltage codes are not stamped on the plate, they are readable on the coils.

\* Special voltage  
\*\* Technical data see CAP. I • 73

- AMP Junior (with or without diode) and Deutsch and with flying leads coils, are available in 12V or 24V DC voltage only.
- Plastic type coils are available in 12V, 24V, 28V or 110V DC voltage only.

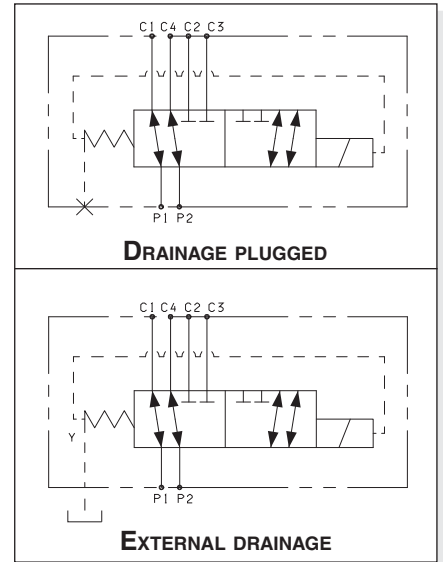

### TAB.2 - VARIANTS

No variant (without connectors)	S1(*)
Viton	SV(*)
Emergency button	ES(*)
Rotary emergency button	P2(*)
AMP Junior coil	AJ(*)
AMP Junior coil and integrated diode	AD(*)
Coil with flying leads (175mm)	SL
Deutsch DT04-2P Coil type	CZ
Plastic type coil D15	RS(*)

Other variants available on request.

(\*) Coils with Hirschmann and AMP Junior connection supplied without connectors. The connectors can be ordered separately, CAP. I • 20.

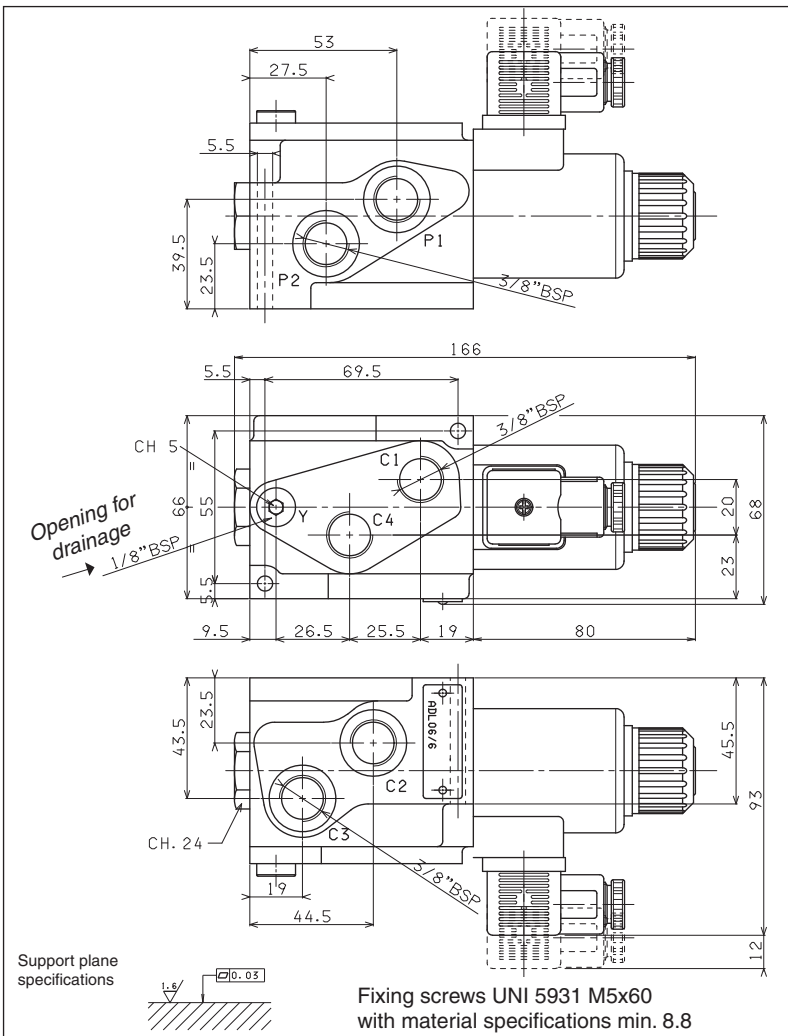

### PRESSURE DROPS

Curve n° 1:

- P1 → C1
- P1 → C2
- P2 → C3
- P2 → C4

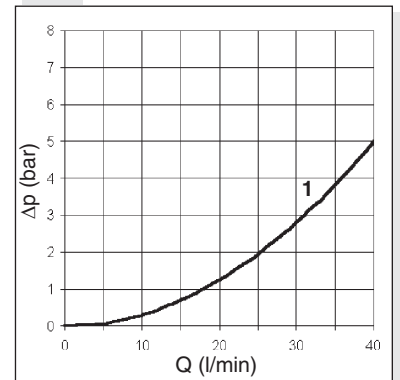

**BDL066...**

"40W" DC COILS	CAP. I • 74
STANDARD CONNECTORS	CAP. I • 20

**BDL066... FLOW DIVERSION VALVES**

The 6 way flow diversion valves, type BDL.06.6, are special solenoid valves which allow the simultaneous connection of two systems. With all user ports on the same side, these valves allow to simplify the layout of hydraulic plant. As they are moved from high performances solenoids they don't need the external drainage.

This valves can manage high hydraulic powers with a low pressure drop.

Max. pressure	250 bar
Max. flow	50 l/min
Overlap	negative
Hydraulic fluids	Mineral oils DIN 51524
Fluid viscosity	10 ÷ 500 mm <sup>2</sup> /s
Fluid temperature	-25°C ÷ 75°C
Ambient temperature	-25°C ÷ 60°C
Max. contamination level	class 10 in accordance with NAS 1638 with filter $\beta_{25} \geq 75$
Weight	3 Kg

**ORDERING CODE**

<b>BDL</b>	Flow diversion valves
<b>06</b>	Size NG06
<b>6</b>	No. of way
<b>W</b>	Threaded connectors 3/8"BSP
<b>I</b>	Internal drainage
<b>*</b>	Voltage (Tab. 1)
<b>**</b>	Variants (Tab. 2)
<b>1</b>	Serial No.

**TAB.1 - 40W COIL****DC VOLTAGE**

<b>L</b>	12V
<b>M</b>	24V
<b>N</b>	48V*
<b>W</b>	Without DC coils

Voltage codes are not stamped on the plate, their are readable on the coils.

\* Special voltage

**TAB.2 - VARIANTS**

No variant (without connectors)	S1(*)
Viton	SV(*)
Emergency button	ES(*)
Rotary emergency button	P2(*)
Deutsch DT04-2P Coil type	CZ

Other variants available on request.

(\*) Coils with Hirschmann connection supplied without connectors. The connectors can be ordered separately, CAP. I • 20.

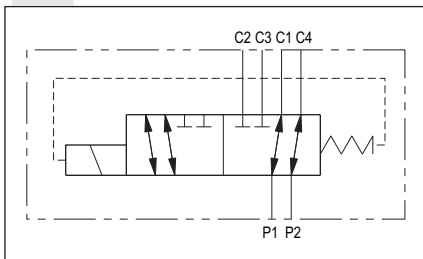
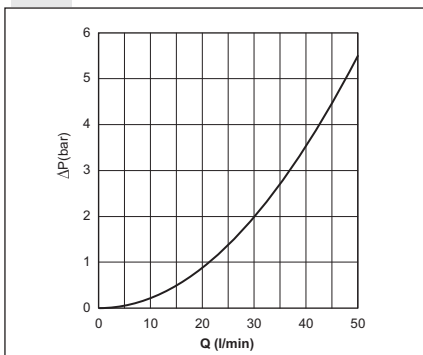
**HYDRAULIC SYMBOL****PRESSURE DROPS**

P1 → C1 , P1 → C2  
P2 → C4 , P2 → C3

The fluid used is a mineral oil with a viscosity of 46 mm<sup>2</sup>/s at 40°C; the tests have been carried out at a fluid temperature of 40°C.

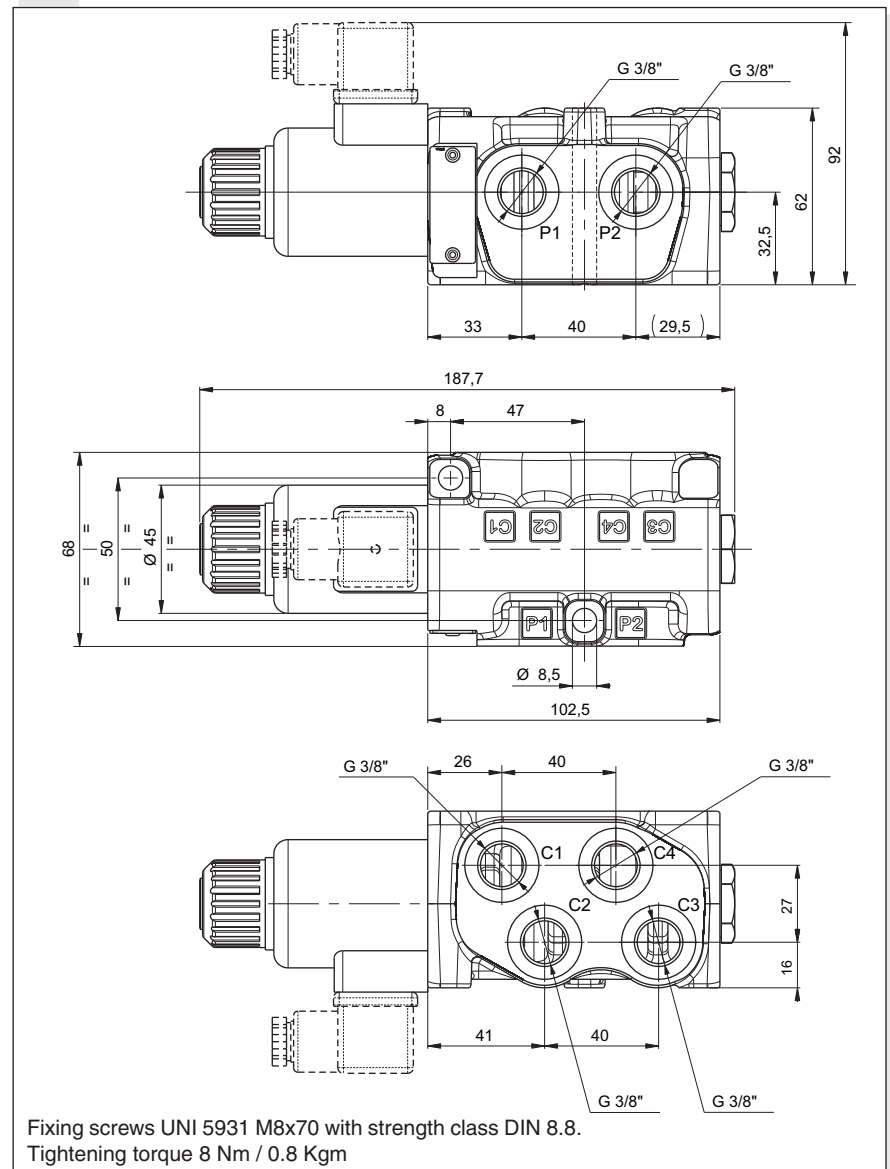
**OVERALL DIMENSIONS**



# CDL106... STACKABLE CIRCUIT SELECTOR VALVES

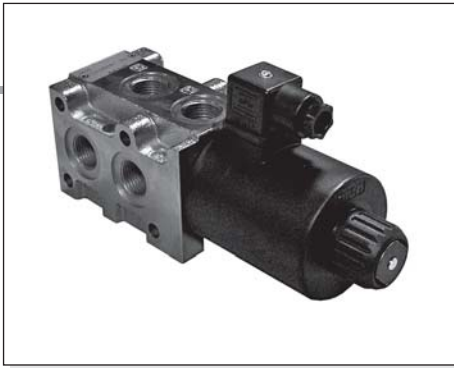

The stackable circuit selector valves, type CDL.10.6, allows one single drive of 6 users with 5 elements connected in series.

As they are moved from high performances solenoids they don't need the external drainage.

This valves can manage high hydraulic powers with a minimal pressure drop.

Max. pressure	250 bar
Max. flow	80 l/min
Overlap	negative
Hydraulic fluids	Mineral oils DIN 51524
Fluid viscosity	10 ÷ 500 mm <sup>2</sup> /s
Fluid temperature	-25°C ÷ 75°C
Ambient temperature	-25°C ÷ 60°C
Max. contamination level	class 10 in accordance NAS with 1638 with filter β <sub>25</sub> <sup>375</sup>
Weight	see "Overall dimension"

<b>CDL106...</b>	
"A16" DC Coils	CAP. I • 74
CONNECTORS STANDARD	CAP. I • 20

### ORDERING CODE

<b>CDL</b>	Stackable circuit selector valve
<b>10</b>	Size NG10
<b>6</b>	No. of way (single element)
<b>*</b>	W = Threaded connectors 1/2" BSP U = Threaded connectors SAE 107/8"-14 UNF
<b>I</b>	Internal drainage
<b>*</b>	No. of elements: 1 / 2 / 3 / 4 / 5
<b>*</b>	Voltage (Tab. 1)
<b>**</b>	Variants (Tab. 2)
<b>1</b>	Serial No.

### TAB.1 - A16 COIL

DC VOLTAGE **	
L	12V
M	24V
N	48V*
P	110V*
Z	102V*
X	205V*
W	Without DC coil

115Vac/50Hz
120Vac/60Hz with rectifier

230Vac/50Hz
240Vac/60Hz with rectifier

Voltage codes are not stamped on the plate, they are readable on the coils.

\* Special voltage  
\*\* Technical data see CAP. I • 74

### TAB.2 - VARIANTS

No variant (without connectors)	S1(*)
Viton	SV(*)
Emergency button	ES(*)
Rotary emergency button	P2(*)

Other variants available on request.

(\*) Coils with Hirschmann connection supplied without connectors. The connectors can be ordered separately, CAP. I • 20.

### HYDRAULIC SYMBOLS

#### SINGLE ELEMENT

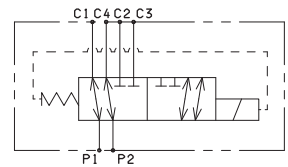

#### MULTISTATION CONNECTION

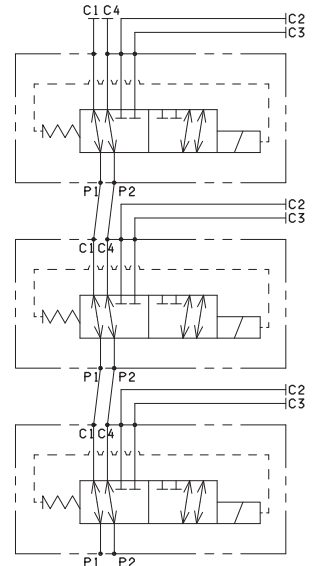

### PRESSURE DROPS

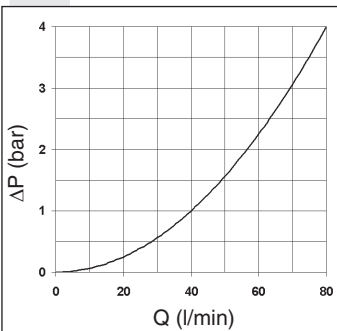

— P1 → C1, P1 → C2,  
P2 → C3 e P2 → C4

The fluid used is a mineral oil with a viscosity of 46 mm<sup>2</sup>/s at 40°C; the tests have been carried out at a fluid temperature of 40°C.

Fixing screws UNI 5931 M6x60 with material specifications min. 8.8  
Tightening torque for studs 8 Nm / 0.8 Kg  
Tightening torque for rods 20 Nm / 2 Kg

### OVERALL DIMENSIONS

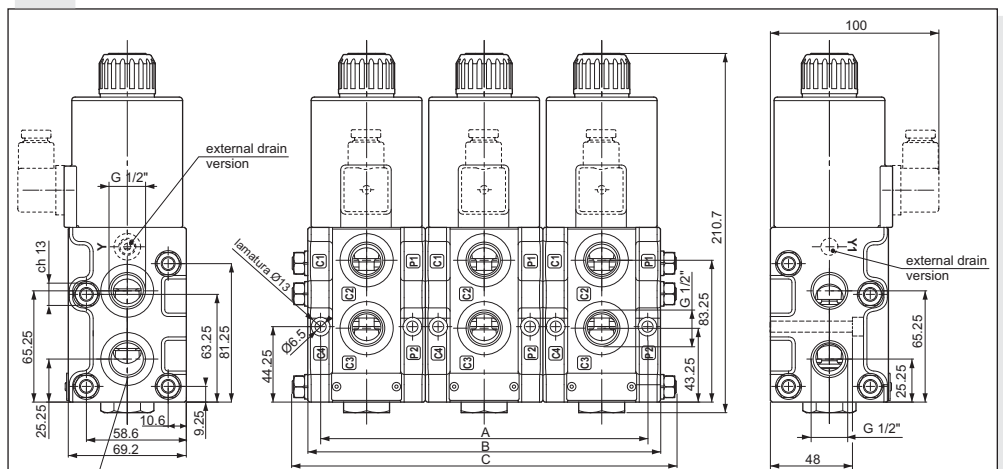

N. 2 O-ring  
1/2" BSP: 2-024  
SAE107/8"-14 UNF: 2-025

No. of elements	No. of way	A	B	C	Weight (Kg)	Kit spare part code* (rods and studs)
1	06	54	69	-	4,5	/
2	08	123	138	160	9,3	V89.56.0001
3	10	192	207	226	14	V89.56.0002
4	12	261	276	296	18,5	V89.56.0003
5	14	330	345	365	23,3	V89.56.0004

(\*) For multiple composition rods and studs are available.



## ADL106... FLOW DIVERSION VALVES

The 6 way flow diversion valves are special solenoid valves which allow the simultaneous connection of two systems.

In order to obtain valve's working at pressure of 250 bar up to 320 bar (external drainage) the G 1/8" BSP plug must be removed to Y connector.

Max. pressure (without drainage, Y plugged)	250 bar
Max. pressure (external drainage)	320 bar
Max. flow	80 l/min
Fluid viscosity	10 ÷ 500 mm <sup>2</sup> /s
Fluid temperature	-25°C ÷ 75°C
Ambient temperature	-25°C ÷ 60°C
Max. contamination level	class 10 in accordance with NAS 1638 with filter $\beta_{25} \geq 75$
Weight	3,6 Kg

### ADL106...

"A16" DC COILS	CAP. I • 74
STANDARD CONNECTORS	CAP. I • 20

### ORDERING CODE

<b>ADL10</b>	Flow diversion valves NG10
<b>6</b>	No. of way
<b>J</b>	Connectors 3/4"BSP
<b>I</b>	Drainage plugged
<b>*</b>	Voltage (see table 1)
<b>**</b>	Variants (see table 2)
<b>1</b>	Serial No.

### TAB.1 - A16 COIL

#### DC VOLTAGE \*\*

<b>L</b>	12V	115Vac/50Hz 120Vac/60Hz with rectifier
<b>M</b>	24V	
<b>N</b>	48V*	230Vac/50Hz 240Vac/60Hz with rectifier
<b>P</b>	110V*	
<b>Z</b>	102V*	Without DC coil
<b>X</b>	205V*	
<b>W</b>	Without DC coil	

Voltage codes are not stamped on the plate, their are readable on the coils.

\* Special voltage

\*\* Technical data see CAP. I • 74

### DRAINS AND HYDRAULIC SYMBOLS

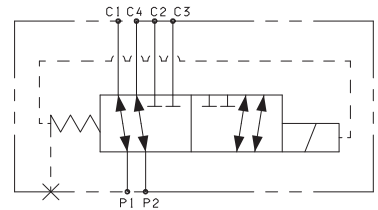

**DRAINAGE PLUGGED**

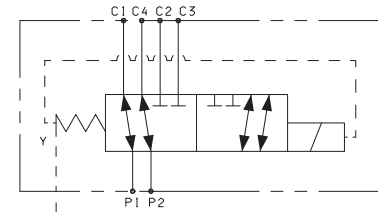

**EXTERNAL DRAINAGE**

### TAB.2 - VARIANTS

No variant (without connectors)	S1(*)
Viton	SV(*)
Emergency button	ES(*)
Rotary emergency button	P2(*)

Other variants available on request.

(\*) Coils with Hirschmann and AMP Junior connection supplied without connectors. The connectors can be ordered separately, CAP. I • 20.

### PRESSURE DROPS

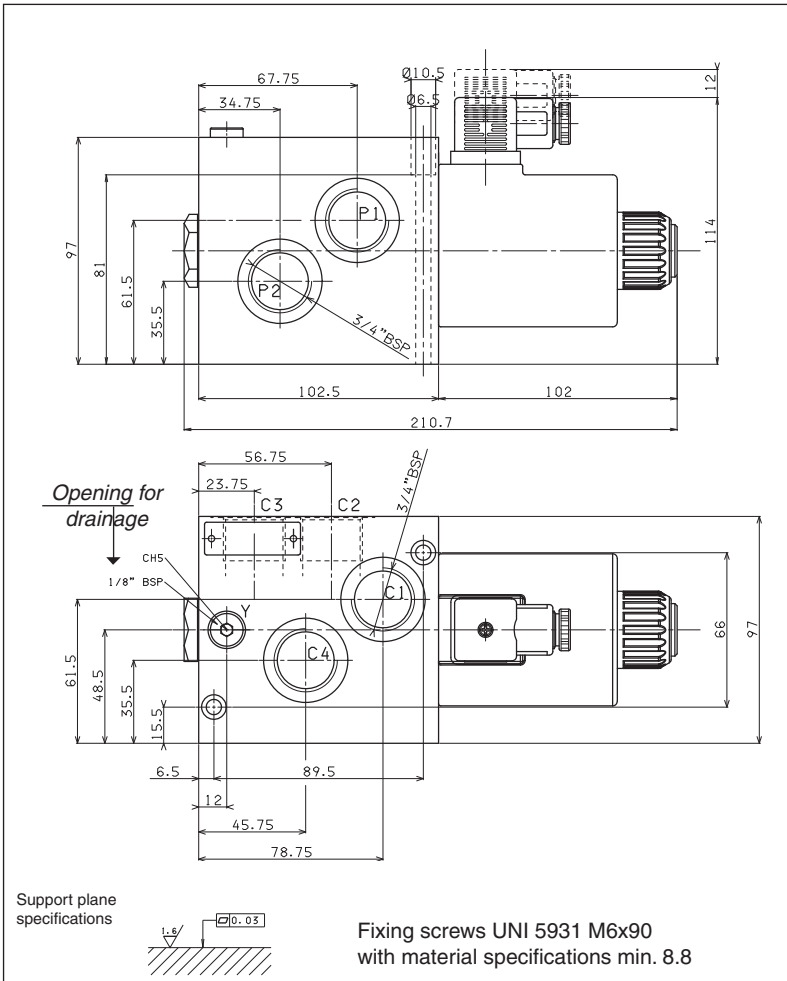
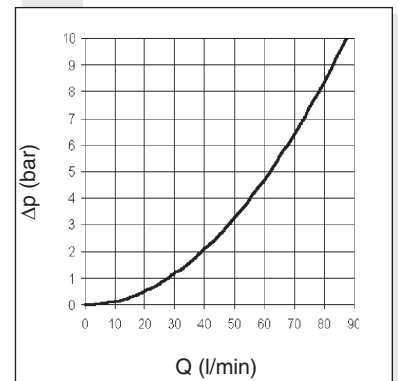

## "A09" DC COILS FOR CDL04...



Type of protection (in relation to connector used)	IP 65
Number of cycle	18.000/h
Supply tolerance	±10%
Ambient temperature	-30°C ÷ 60°C
Duty cycle	100% ED
Insulation class wire	H
Weight	0,215 Kg

• The AMP Junior coil, the Deutsch coil with bidirectional diode and the coil with flying leads (with or without diode) coils are available in 12V or 24V DC voltage only.

### AMP JUNIOR (AJ)

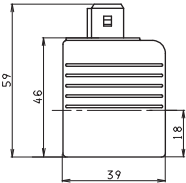

VOLTAGE (V)	MAX WINDING TEMPERATURE (AMBIENT TEMPERATURE 25°C)	RATED POWER (W)	RESISTANCE AT 20°C (OHM) ±7%
12V	123°C	27	5.3
24V	123°C	27	21.3
48V*	123°C	27	85.3
102V(**)	123°C	27	392
110V(**)	123°C	27	448
205V(**)	123°C	27	1577

\* Special voltages

\*\* The european low voltage directive is applied to electrical equipments used at a nominal voltages between 50 and 1000 VAC or 75 and 1500 VDC. In conformity with the low directive each part of the manifold or the subplate on which the valve is mounted should be connected to a protective earth with a resistance less than 0.1 ohms.

### DEUTSCH COIL WITH BIDIR. DIODE (CX) DT04 - 2P

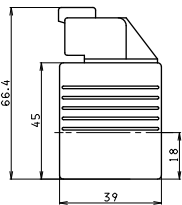

### FLYING LEADS (FL) LEADS WITH DIODO (LD)

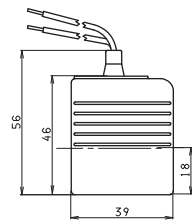

### EMERGENCY (COILS WITH HIRSCHMANN CONNECTION)

#### MANUAL WITHOUT CONN. (ES) MANUAL WITH CONN. (E1)

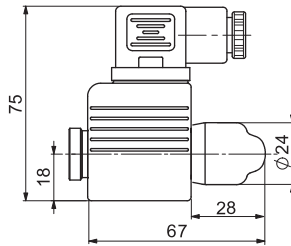

#### ROTARY WITHOUT CONNECTOR (P2\*) ROTARY WITH CONNECTOR (P1\*)

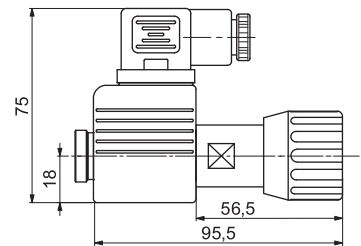

(\*) Emergency tightening torque max. 6±9 Nm / 0.6 ÷ 0.9 Kgm with CH n. 22

## "D15" DC COILS FOR ADL06... AND A66..



Type of protection (in relation to the connector used)	IP 66
Number of cycles	18.000/h
Supply tolerance	±10%
Ambient temperature	-25°C ÷ 60°C
Duty cycle	100% ED
Insulation class wire	H
Weight	0,354 Kg

• AMP Junior coils (with or without diode) and coils with flying leads and coils type Deutsch, are available in 12V or 24V DC voltage only.

• The pastic type coil (BR variant) is available in 12V, 24V, 28V or 110V DC voltage only.

• Emergency, plastic coil, and Amp Junior, leads or deutch coils, are not available for A66 valve.

### eCOAT COIL (RS)

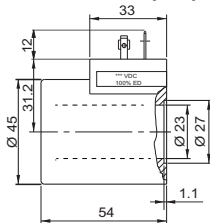

VOLTAGE (V)	MAX WINDING TEMPERATURE (AMBIENT TEMPERATURE 25°C)	RATED POWER (W)	RESISTANCE AT 20°C (OHM) ±10%
12V	110°C	30	4.8
24V	110°C	30	18.8
28V*	110°C	30	25.6
48V*	110°C	30	75.2
102V(**)	110°C	30	340
110V(**)	110°C	30	387
205V(**)	110°C	30	1375

\* Special voltages

\*\* The european low voltage directive is applied to electrical equipments used at a nominal voltages between 50 and 1000 VAC or 75 and 1500 VDC. In conformity with the low directive each part of the manifold or the subplate on which the valve is mounted should be connected to a protective earth with a resistance less than 0.1 ohms.

### FLYING WITH LEADS COIL (SL)

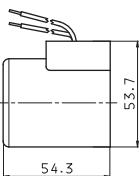

### AMP JUNIOR (AJ) AJ + DIODE (AD)

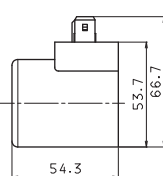

### DEUTSCH DT04 - 2P (CZ) CZ + eCOAT (R6)

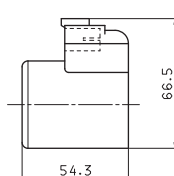

### EMERGENCY (COILS WITH HIRSCHMANN CONNECTION)

#### MANUAL WITHOUT CONNECTOR (ES) MANUAL WITH CONNECTOR (E1)

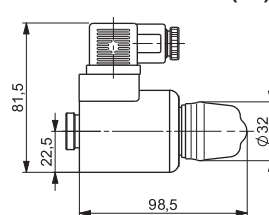

#### ROTARY WITHOUT CONNECTOR (P2) ROTAN ROTARY WITH CONNECTOR (P1)

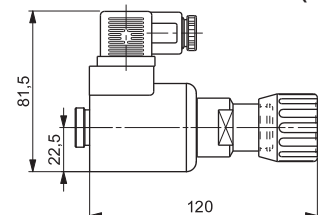

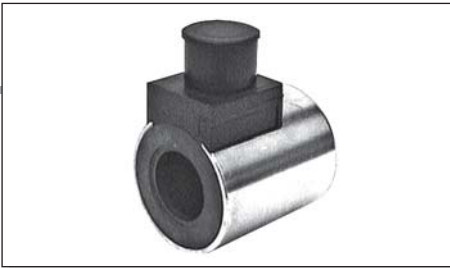

## "40W" DC COILS FOR CDL06...

Type of protection (in relation to the connector used)	IP 66
Number of cycles	18.000/h
Supply tolerance	+10% / -10%
Ambient temperature	-54°C ÷ 60°C
Duty cycle	100% ED
Insulation class wire	H
Weight	0,354 Kg

VOLTAGE (V)	MAX. WINDING TEMPERATURE (AMBIENT TEMPERATURE 25°C)	RATED POWER (W)	RESISTANCE AT 20°C (OHM) ±10%
12V	135°C	40	3.6
24V	135°C	40	14.4

IT40W - 01/2004/i

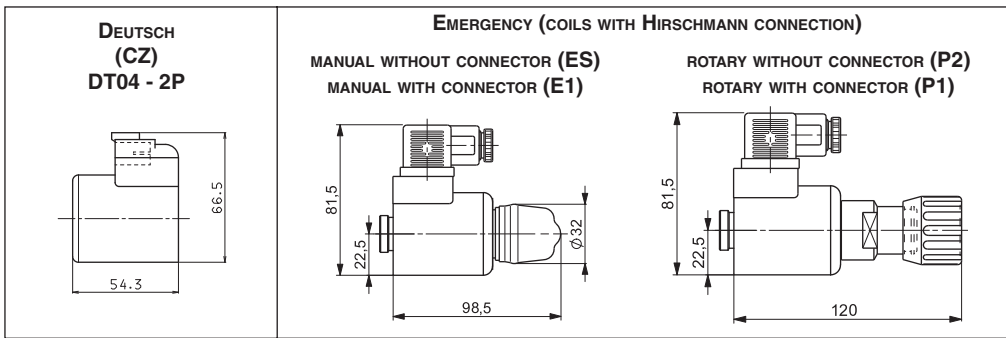

## "A16" DC COILS FOR ADL10 AND CDL10

Type of protection (in relation to the connector used)	IP 65
Number of cycles	18.000/h
Supply tolerance	±10%
Ambient temperature	-30°C ÷ 60°C
Duty cycle	100% ED
Insulation class wire	H
Weight	0,9 Kg

VOLTAGE (V)	MAX WINDING TEMPERATURE (AMBIENT TEMPERATURE 25°C)	RATED POWER (W)	RESISTANCE AT 20°C (OHM) ±7%
12V	106°C	45	3.2
24V	113°C	45	12.4
48V*	-	45	-
102V(**)	-	45	-
110V(**)	118°C	45	268
205V(**)	-	45	-

\* Special voltages

\*\* The european low voltage directive is applied to electrical equipments used at a nominal voltages between 50 and 1000 VAC or 75 and 1500 VDC. In conformity with the low directive each part of the manifold or the subplate on which the valve is mounted should be connected to a protective earth with a resistance less than 0.1 ohms.

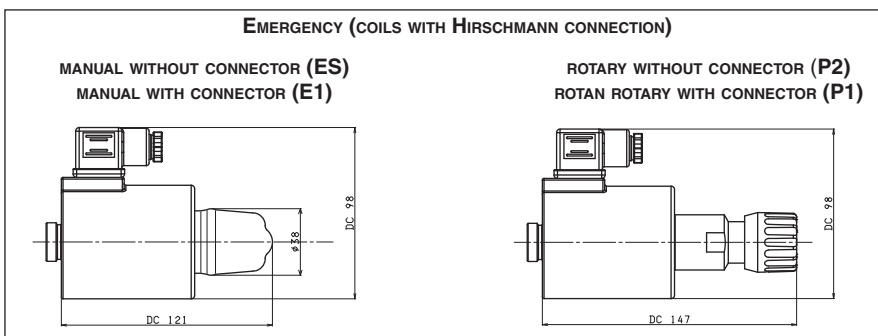

## ABBREVIATIONS

<b>AP</b>	HIGH PRESSURE CONNECTION
<b>AS</b>	PHASE LAG (DEGREES)
<b>BP</b>	LOW PRESSURE CONNECTION
<b>C</b>	STROKE (MM)
<b>CH</b>	ACROSS FLATS
<b>Ch</b>	INTERNAL ACROSS FLATS
<b>DA</b>	AMPLITUDE DECAY (dB)
<b>DP</b>	DIFFERENTIAL PRESSURE (BAR)
<b>F</b>	FORCE (N)
<b>I%</b>	INPUT CURRENT (A)
<b>M</b>	MANOMETER CONNECTION
<b>NG</b>	KNOB TURNS
<b>OR</b>	SEAL RING
<b>P</b>	LOAD PRESSURE (BAR)
<b>PARBAK</b>	PARBAK RING
<b>PL</b>	PARALLEL CONNECTION
<b>Pr</b>	REDUCED PRESSURE (BAR)
<b>Q</b>	FLOW (L/MIN)
<b>QP</b>	PUMP FLOW (L/MIN)
<b>SE</b>	ELASTIC PIN
<b>SF</b>	BALL
<b>SR</b>	SERIES CONNECTION
<b>X</b>	PILOTING
<b>Y</b>	DRAINAGE

## SUBPLATE MOUNTING PRESSURE CONTROL VALVES



PV*3 / PV*U3...	CAP. II • 2
PV*5 / PV*U5...	CAP. II • 4

2

## SUBPLATE MOUNTING PRESSURE CONTROL VALVES



V*P...	CAP. II • 6
V*L...	CAP. II • 6
BSVMP...	CAP. II • 11

## PV\*3 / PV\*U3 PRESSURE REDUCING AND SEQUENCING VALVES CETOP 3/NG6

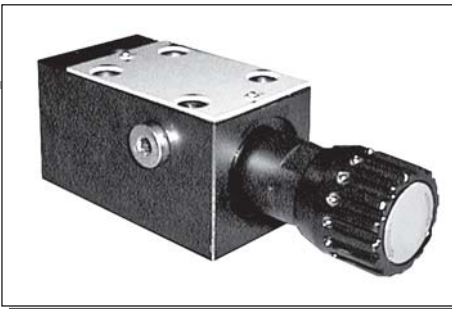

PVR3 / PVS3...

These subplate mounting piloted type pressure reducing and sequencing valves ensure a minimum variation in their calibrated pressure value with changing flow rate.

They are normally supplied with internal piloting and internal drainage on B, but they are already provided with a hole on the front cover to allow for external drainage.

They are available with two different types of adjustment and three calibrated ranges that cover pressure 7 ÷ 250 bar, with and without check valve.

The adjustment is carried out by means of a grub screw or a metric plastic knob.

Max. pressure	320 bar
Setting ranges	Spring 1 max. 60 bar
	Spring 2 max. 120 bar
	Spring 3 max. 250 bar

Maximum allowed $\Delta p$ pressure between the inlet and outlet pressure (PVR only)	150 bar
Max. flow	40 l/min
Draining on port T	0.5 ÷ 0.7 l/min
Hydraulic fluids	Mineral oils DIN 51524
Fluid viscosity	10 ÷ 500 mm <sup>2</sup> /s
Fluid temperature	-25°C ÷ 75°C
Ambient temperature	-25°C ÷ 60°C
Max. contamination lever	class 10 in accordance with NAS 1638 with filter $\beta_{25} \geq 75$
Weight (without check valve)	1,5 Kg
Weight (with check valve)	2 Kg

### ORDERING CODE

<b>PV*</b>	R = Reducing valve S = Sequencing valve
<b>U</b>	Check valve (omit if not required)
<b>3</b>	CETOP 3/NG6
<b>*</b>	Type of adjustment: M = Plastic knob C = Grub screw
<b>*</b>	Setting ranges 1 = max. 60 bar (white spring) 2 = max. 120 bar (yellow spring) 3 = max. 250 bar (green spring)
<b>**</b>	00 = No variant V1 = Viton
<b>1</b>	Serial No.

### HYDRAULIC SYMBOLS

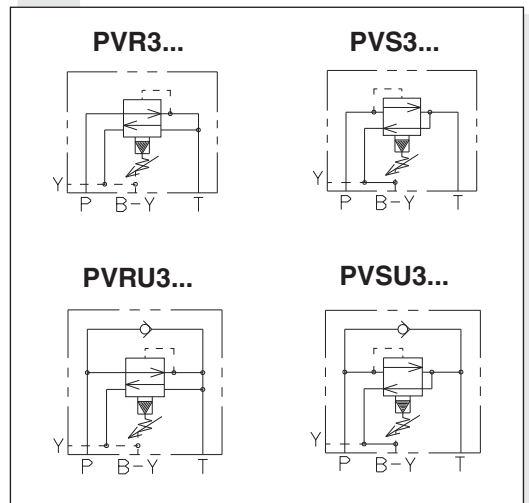

### DIAGRAMS

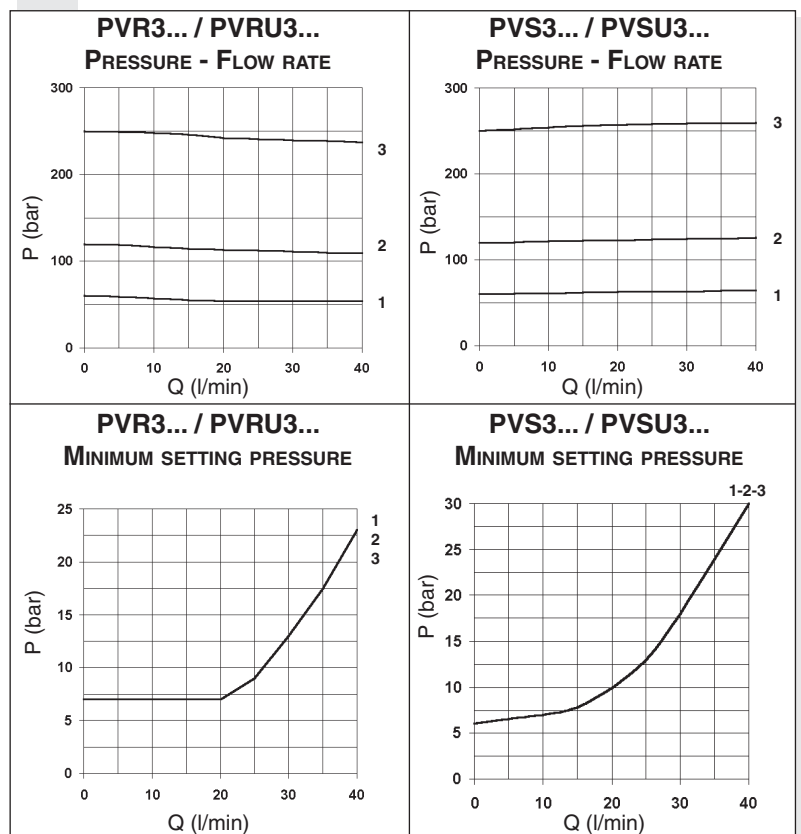

Curves n° 1 - 2 - 3 = setting ranges

The fluid used is a mineral oil with viscosity of 46 mm<sup>2</sup>/s at 40°C. The tests were carried out at a fluid temperature of 50°C.

OVERALL DIMENSIONS

REDUCING VALVE AND SEQUENCING VALVE PVR3... / PVS3... CETOP 3

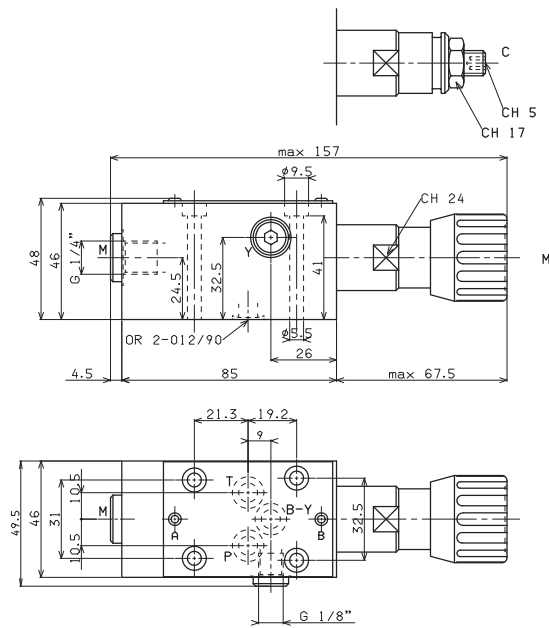

Type of adjustment

- M Plastic knob
- C Grub screw

Fixing screws UNI 5931 M5x50  
with material specifications min. 8.8  
Tightening torque 5 Nm / 0.5 Kgm

Support plane specifications

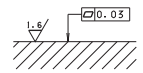

OVERALL DIMENSIONS

REDUCING VALVE WITH CHECK VALVE AND SEQUENCING VALVE WITH CHECK VALVE PVRU3... / PVSU3... WITH CHECK VALVE CETOP 3

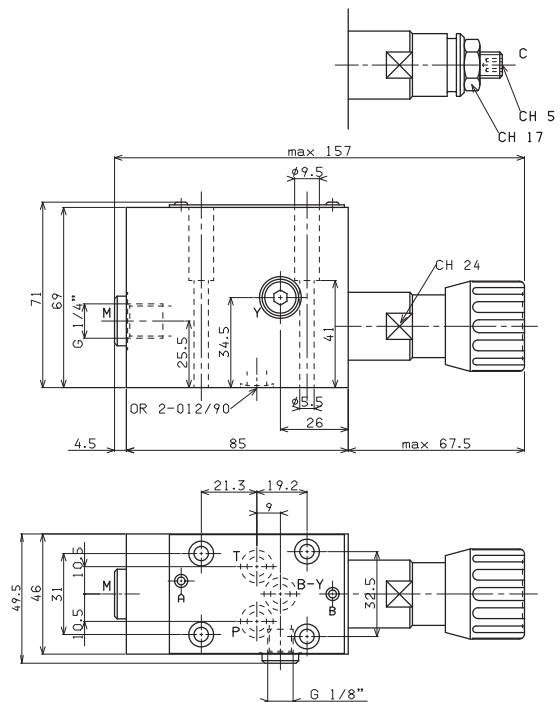

Type of adjustment

- M Plastic knob
- C Grub screw

Fixing screws UNI 5931 M5x50  
with material specifications min. 8.8  
Tightening torque 5 Nm / 0.5 Kgm

Support plane specifications

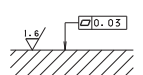



PVR5 / PVS5...

## PV\*3 / PV\*U3 PRESSURE REDUCING AND SEQUENCING VALVES CETOP 3/NG6

These subplate mounting piloted type pressure reducing and sequencing valves ensure a minimum variation in their calibrated pressure value with changing flow rate.

They are normally supplied with internal piloting and internal drainage on B, but they are already provided with a hole on the front cover to allow for external drainage.

They are available with two different types of adjustment and three calibrated ranges that cover pressure 7 ÷ 250 bar, with and without check valve.

The adjustment is carried out by means of a grub screw or a metric plastic knob.

Max. pressure	320 bar	
Setting ranges	Spring 1	max. 60 bar
	Spring 2	max. 120 bar
	Spring 3	max. 250 bar
Maximum allowed $\Delta p$ pressure between the inlet and outlet pressure (PVR only)	150 bar	
Max. flow	40 l/min	
Draining on port T	0.5 ÷ 0.7 l/min	
Hydraulic fluids	Mineral oils DIN 51524	
Fluid viscosity	10 ÷ 500 mm <sup>2</sup> /s	
Fluid temperature	-25°C ÷ 75°C	
Ambient temperature	-25°C ÷ 60°C	
Max. contamination lever	class 10 in accordance with NAS 1638 with filter $\beta_{25} \geq 75$	
Weight (without check valve)	1,5 Kg	
Weight (with check valve)	2 Kg	

### ORDERING CODE

<b>PV*</b>	<b>R</b> = Reducing valve <b>S</b> = Sequencing valve
<b>U</b>	Check valve (omit if not required)
<b>3</b>	CETOP 3/NG6
<b>*</b>	Type of adjustment: <b>M</b> = Plastic knob <b>C</b> = Grub screw
<b>*</b>	Setting ranges <b>1</b> = max. 60 bar ( <b>white spring</b> ) <b>2</b> = max. 120 bar ( <b>yellow spring</b> ) <b>3</b> = max. 250 bar ( <b>green spring</b> )
<b>**</b>	<b>00</b> = No variant <b>V1</b> = Viton
<b>1</b>	Serial No.

### HYDRAULIC SYMBOLS

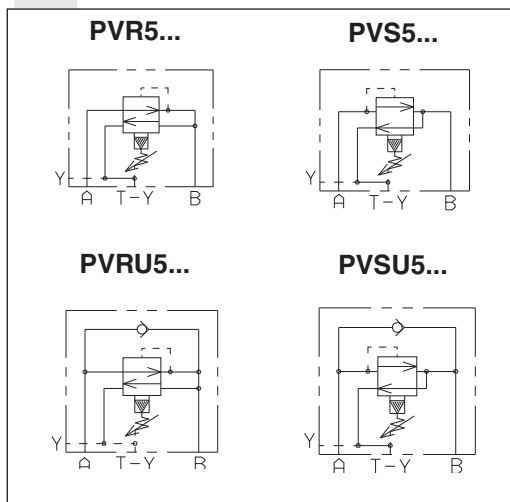

### DIAGRAMS

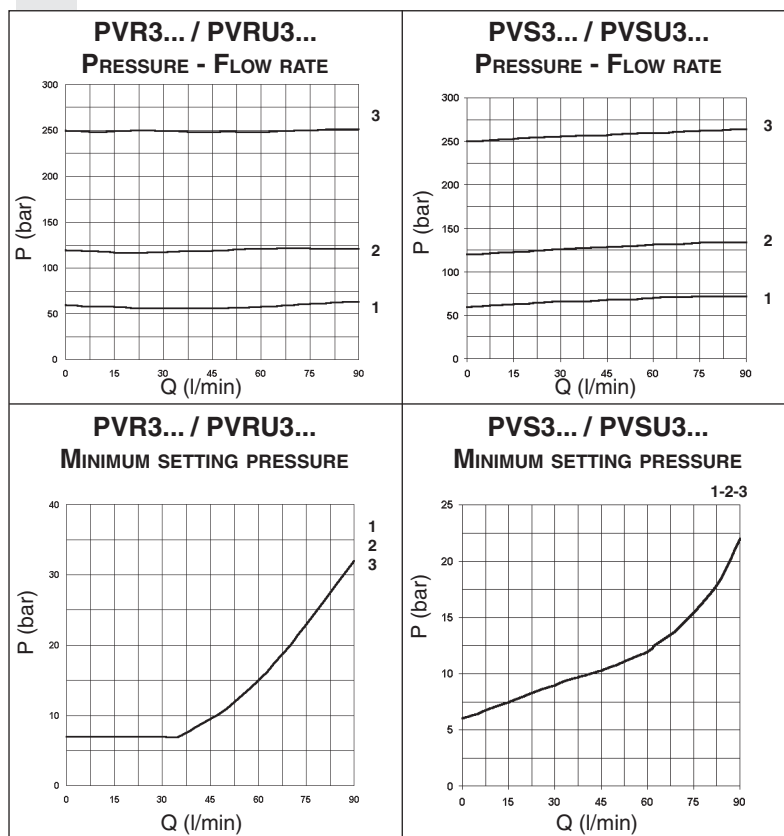



OVERALL DIMENSIONS

REDUCING VALVE  
PVR3... CETOP 3/NG6

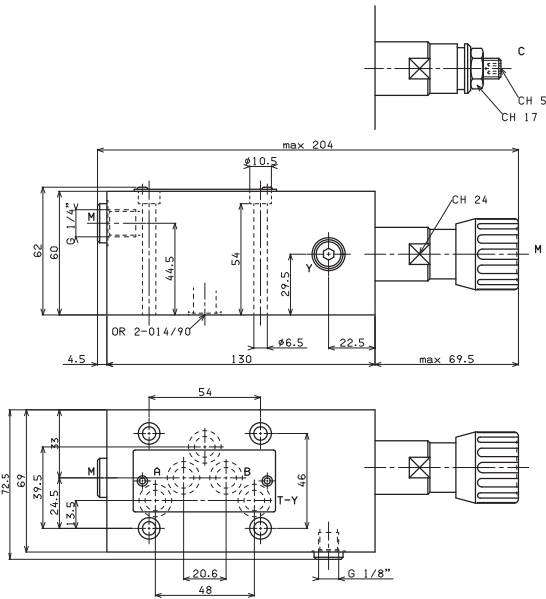

SEQUENCING VALVE  
PVS3... CETOP 3/NG6

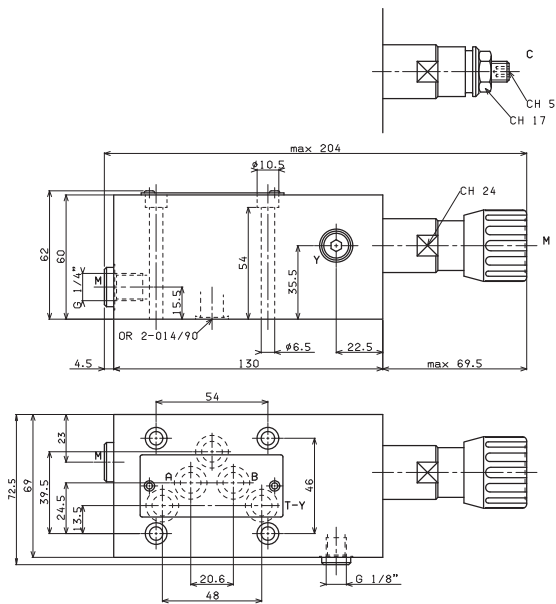

Type of adjustment

- M Plastic knob
- C Grub screw

Fixing screws UNI 5931 M5x50  
with material specifications min. 8.8  
Tightening torque 5 Nm / 0.5 Kgm

Support plane  
specifications

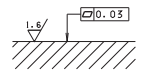

OVERALL DIMENSIONS

REDUCING VALVE WITH CHECK VALVE  
PVRU3... CETOP 3/NG6

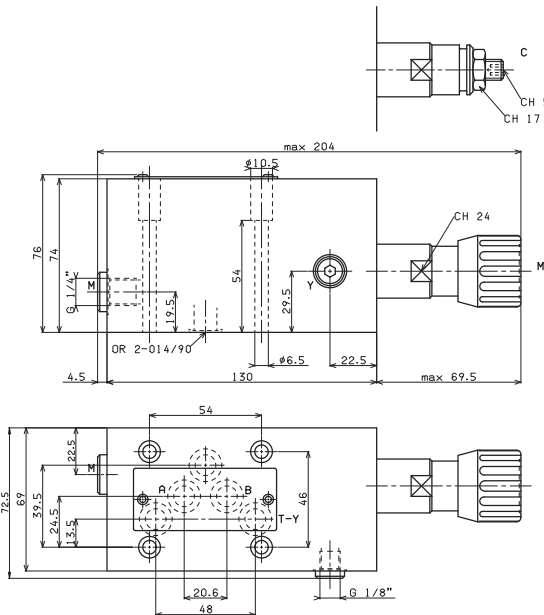

SEQUENCING VALVE WITH CHECK VALVE  
PVSU3... CETOP 3/NG6

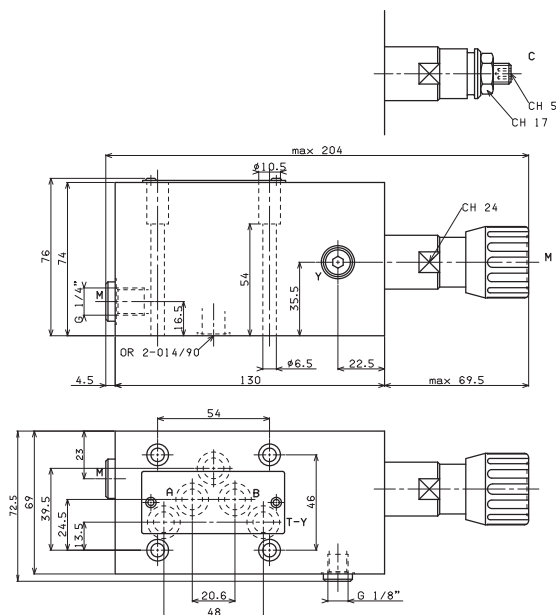

Type of adjustment

- M Plastic knob
- C Grub screw

Fixing screws UNI 5931 M5x50  
with material specifications min. 8.8  
Tightening torque 5 Nm / 0.5 Kgm

Support plane  
specifications

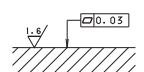

## V\*P PRESSURE CONTROL VALVES PLATE

## V\*L PRESSURE CONTROL VALVES IN LINE

These pressure control valves are available in the basic VMP\* maximum pressure, VSP\* sequence and VUP\* exclusion versions, with a single pressure value and three calibration ranges that cover the band 15 ÷ 400 bar. It is possible to use auxiliary pilot valves, which can be the simple standard AD3E solenoid valve, by the mere exchange of covers.

**These valves have been fitted with an important safety feature for the operation of the system where they are used; a mechanical end of stroke stop prevents the operator from setting pressure values higher than those specified in the catalogue (it is impossible to compress the spring completely). In the standard configuration these valves are supplied with a 1.6 bar main spring and with calibrated  $\varnothing 1$  mm pilot feed orifice (Variant part No. 00).**

Pressure max.		400 bar
Setting ranges	Spring 1	15 ÷ 45 bar
	Spring 2	15 ÷ 145 bar
	Spring 3	45 ÷ 400 bar
Max. flow V*P16...		150 l/min
Max. flow V*P25...		350 l/min
Hydraulic fluids		Mineral oils DIN 51524
Fluid viscosity		10 ÷ 500 mm <sup>2</sup> /s
Fluid temperature		-25°C ÷ 75°C
Ambient temperature		-25°C ÷ 60°C
Max. contamination level	class 10 in accordance with NAS 1638 with filter $\beta_{25} \geq 75$	
Drainage V*P16...		1 ÷ 2 l/min
Drainage V*P25...		1 ÷ 2.5 l/min
Dynamic pressure at drainage		Max. 2 bar
Weight V*P16... (without pilot valve)		3,3 Kg
Weight V*P25... (without pilot valve)		7,4 Kg
Weight V*L16... (without pilot valve)		4,6 Kg
Weight V*L161... (without pilot valve)		4,5 Kg
Weight V*L251... (without pilot valve)		7,7 Kg
Weight V*L25... (without pilot valve)		8,3 Kg

Subplate mounting valves are suitable for covers which do not conform to DIN standards type C\*P16/25.. whilst in line mounting valves are suitable for DIN standards covers type KEC16/25...

### V\*P / V\*L...

V*P...	CAP. II • 7
V*PE...	CAP. II • 8
V*L...	CAP. II • 9 - CAP. II • 10
BSVMP...	CAP. II • 11
KEC16/25...	CAP. II • 9
C*P16/25...	CAP. II • 9
CETOP 3/NG06	CAP. II • 8
STANDARD SPOOLS FOR AD3E	CAP. II • 10
AD3E...	CAP. II • 11
AM3VM...	CAP. II • 9

### ORDERING CODE

<b>V</b>	Valve
<b>*</b>	<b>M</b> = maximum pressure <b>S</b> = sequence <b>U</b> = exclusion (areas rep. 1,15 : 1)
<b>*</b>	<b>P</b> = Plate mounting <b>L</b> = In line mounting
<b>*</b>	<b>E</b> = Presetting for solenoid valve <b>Not for sequencing valve V.S.P...</b> (omit if not required)
<b>***</b>	Size (see overall dimensions) <b>16 - 25</b> = NG16 or NG25 <b>161 - 251</b> = for V*.L... only (in line mounting valve)
<b>*</b>	Type of adjustment: <b>M</b> = Plastic knob <b>C</b> = Grub screw
<b>*</b>	Setting ranges <b>1</b> = 15 ÷ 45 bar ( <b>white spring</b> ) <b>2</b> = 15 ÷ 145 bar ( <b>yellow spring</b> ) <b>3</b> = 45 ÷ 400 bar ( <b>green spring</b> )
<b>**</b>	<b>00</b> = No variant <b>V1</b> = Viton <b>AC</b> = Exclusion valve for accumulators (only for VU*, logic element areas rep. 12.5 : 1) <b>AQ</b> = Presetting for XP3
<b>2</b>	Serial No.

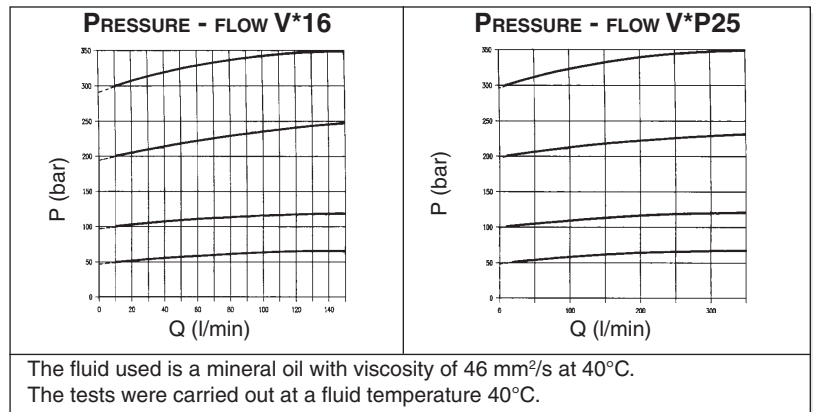

### HYDRAULIC SYMBOLS

<b>VMP16**...</b> <b>VMP25**...</b> <b>Maximum pressure valve</b> Internal piloting and draining			
<b>VSP16**...</b> <b>VSP25**...</b> <b>Sequencing valve</b> Internal piloting External draining			
<b>VUP16**...</b> <b>VUP25**...</b> <b>Exclusion valve</b> External piloting Internal draining			

# V\*P... PRESSURE CONTROL VALVES PLATE

## OVERALL DIMENSIONS V\*P16...

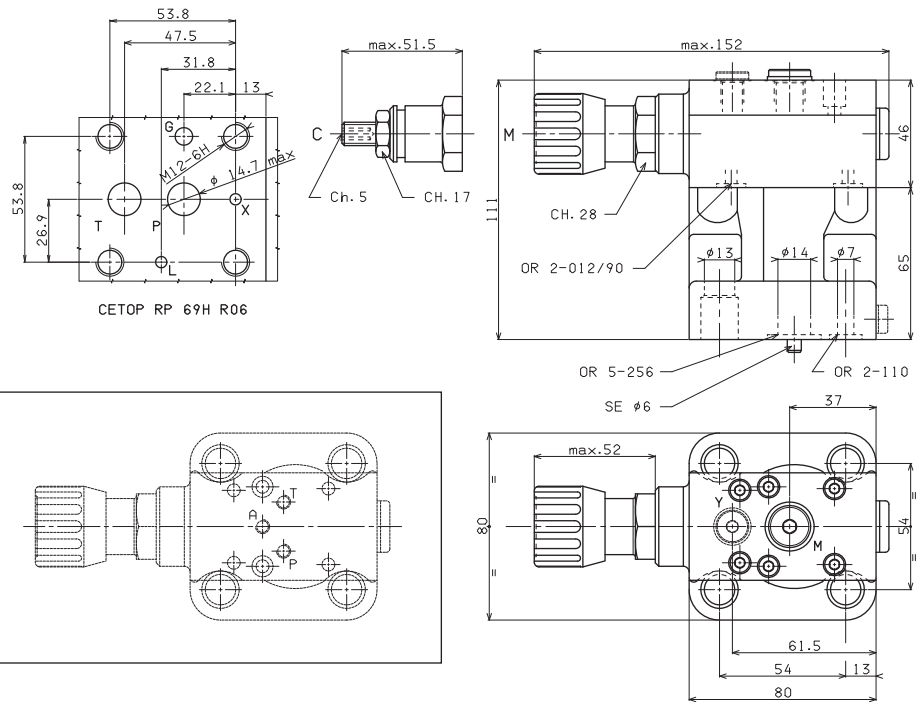

VERSION WITH  
PRESETTING FOR  
SOLENOID VALVE

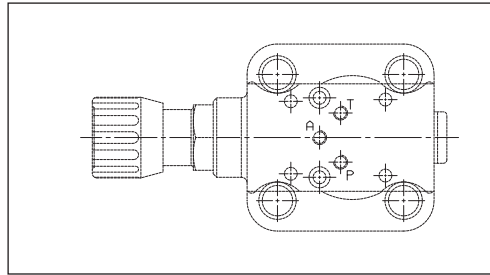

Fixing screws UNI 5931 M12x40 with material specifications min. 8.8  
Tightening torque 70 Nm / 7 Kgm

**M** = 1/4" BSP connector for pressure gauge for maximum pressure valve version only  
**Y** = 1/8" BSP external draining for sequencing valve version only

Support plane  
specifications

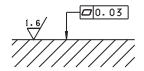

## OVERALL DIMENSIONS V\*P25...

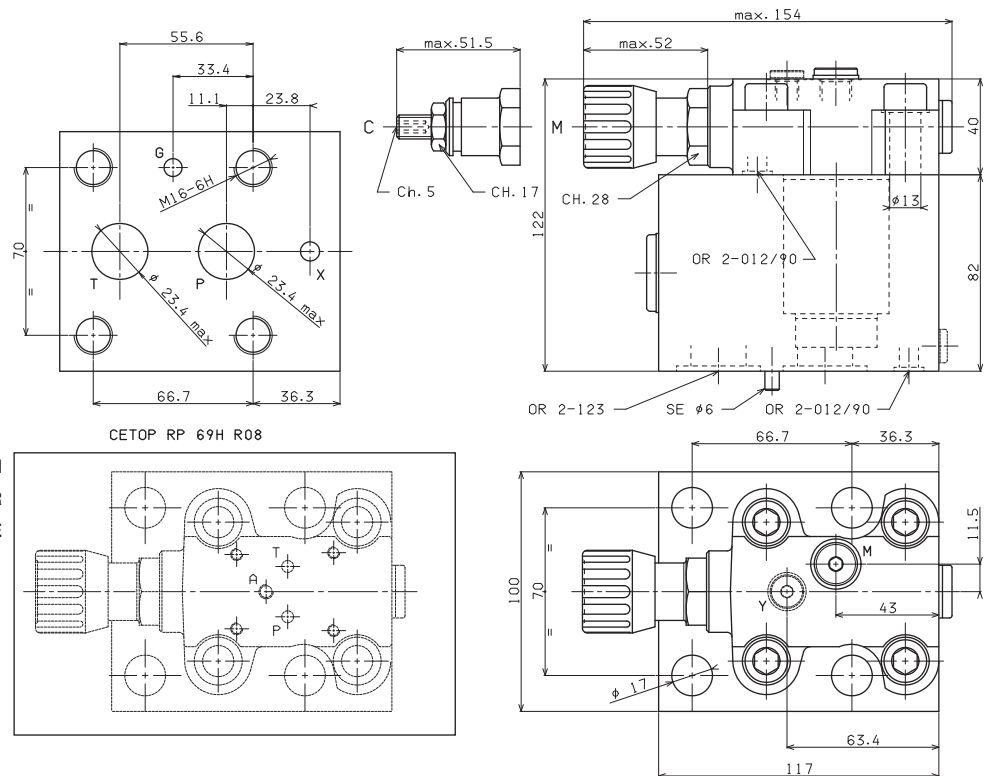

VERSION WITH  
PRESETTING FOR  
SOLENOID VALVE

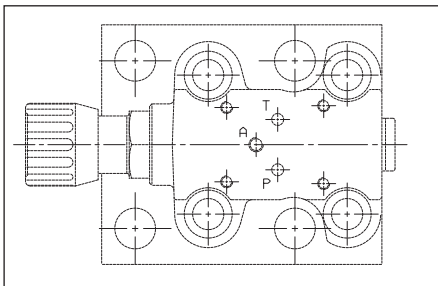

Fixing screws UNI 5931 M16x100 with material specifications min. 8.8  
Tightening torque 70 Nm / 7 Kgm

**M** = 1/4" BSP connector for pressure gauge for maximum pressure valve version only  
**Y** = 1/8" BSP external draining for sequencing valve version only

Support plane  
specifications

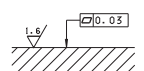

2

# V\*PE... PRESSURE CONTROL VALVES PLATE

## MOUNTING TYPE V\*PE...

2

<p><b>V*PE... + AD3E15E... OR AD3E16E...</b></p> <p>1) Solenoid de-energized, pump to tank. 2) Solenoid energized, circuit pressure controlled by valve on cover. For mounting valves to have normally discharged configuration it is necessary to use an AD3E15F.. or AD3E16F... type solenoid valve, whilst for subplate mounting valves it is necessary to use type AD3E15E.. or AD3E16E..</p>		
<p><b>V*PE... + AD3E15F... OR AD3E16F...</b></p> <p>1) Solenoid de-energized, pump pressure controlled by valve on cover. 2) Solenoid B energized, pump to tank.</p>		
<p><b>V*PE... + AM3VMB... + AD3E15E... OR AD316E...</b></p> <p>1) Solenoid de-energized, pump pressure controlled by valve on cover. 2) Solenoid energized, pump pressure controlled by valve AM3VMB.</p>		
<p><b>V*PE... + AM3VMB... + AD3E02C...</b></p> <p>1) Solenoid de-energized, pump to tank. 2) Solenoid A energized, pump pressure controlled by valve AM3VMB. 3) Solenoid B energized, pump pressure controlled by valve on cover.</p>		
<p><b>V*PE... + AM3VMB... + AD3E01C...</b></p> <p>1) Solenoid de-energized, pump pressure controlled by valve on cover. 2) Solenoid A energized, pump pressure controlled by valve AM3VMAB. 3) Solenoid B energized, pump pressure controlled by valve AM3VMAB.</p>		

# V\*L... PRESSURE CONTROL VALVES IN LINE

## OVERALL DIMENSIONS V\*L16...

1/2" BSP P connector  
3/4" BSP T connector

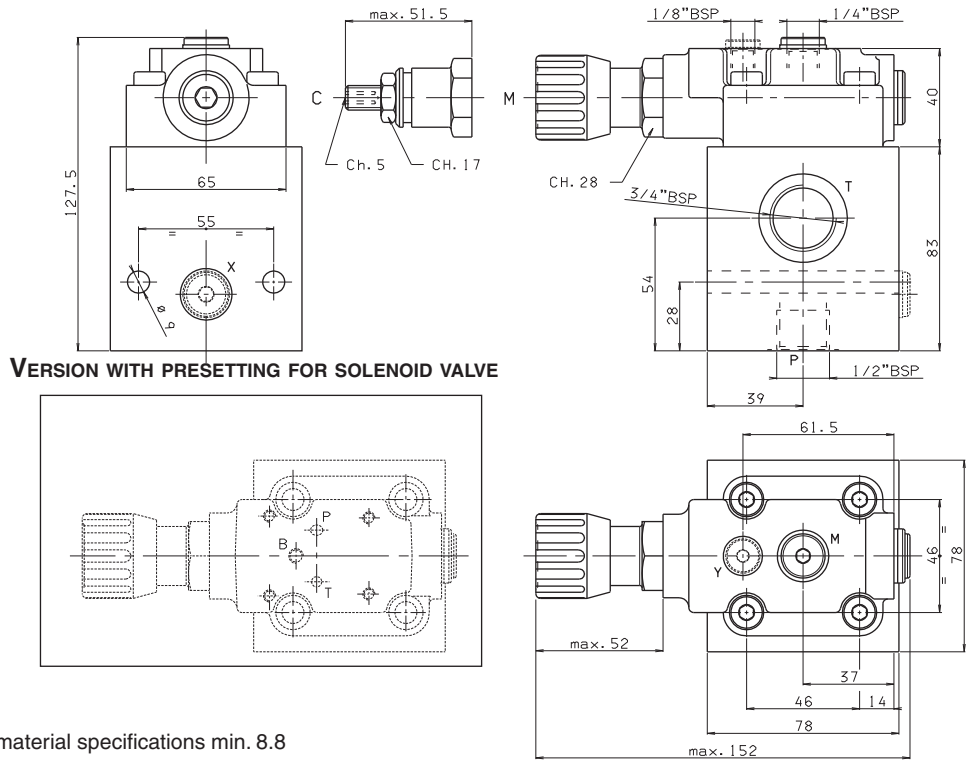

VERSION WITH PRESETTING FOR SOLENOID VALVE

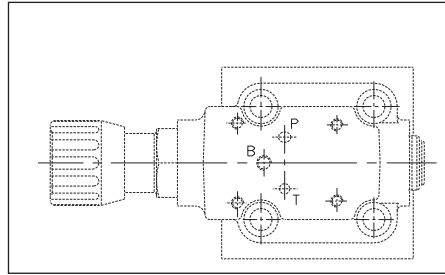

Fixing screws UNI 5931 M8x90 with material specifications min. 8.8  
Tightening torque 24 Nm / 2.4 Kgm

M = 1/4" BSP connector for pressure gauge for maximum pressure valve version only  
Y = 1/8" BSP external draining for sequencing valve version only

2

## OVERALL DIMENSIONS V\*L161...

3/4" BSP P and T connectors

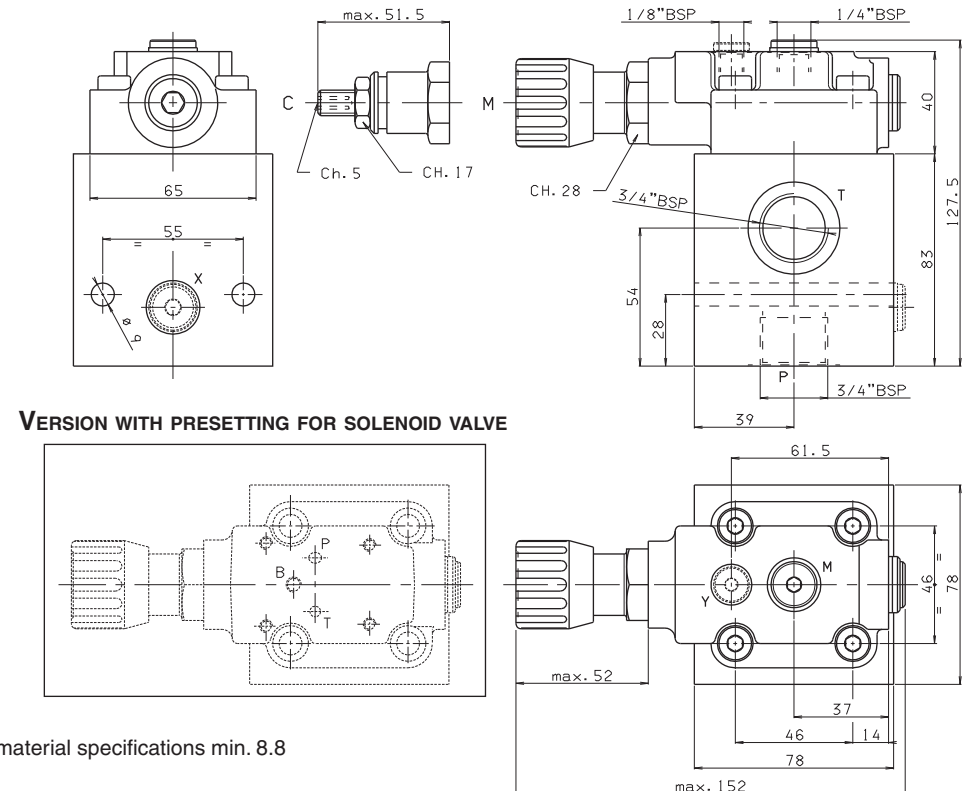

VERSION WITH PRESETTING FOR SOLENOID VALVE

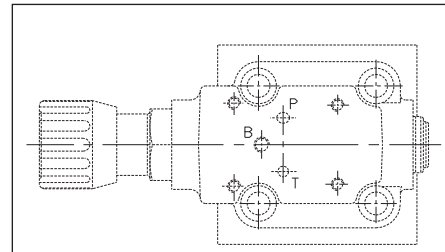

Fixing screws UNI 5931 M8x90 with material specifications min. 8.8  
Tightening torque 24 Nm / 2.4 Kgm

M = 1/4" BSP connector for pressure gauge for maximum pressure valve version only  
Y = 1/8" BSP external draining for sequencing valve version only

# V\*L... PRESSURE CONTROL VALVES IN LINE

## OVERALL DIMENSIONS V\*L25...

1" BSP P connector  
1 1/4" BSPT connector

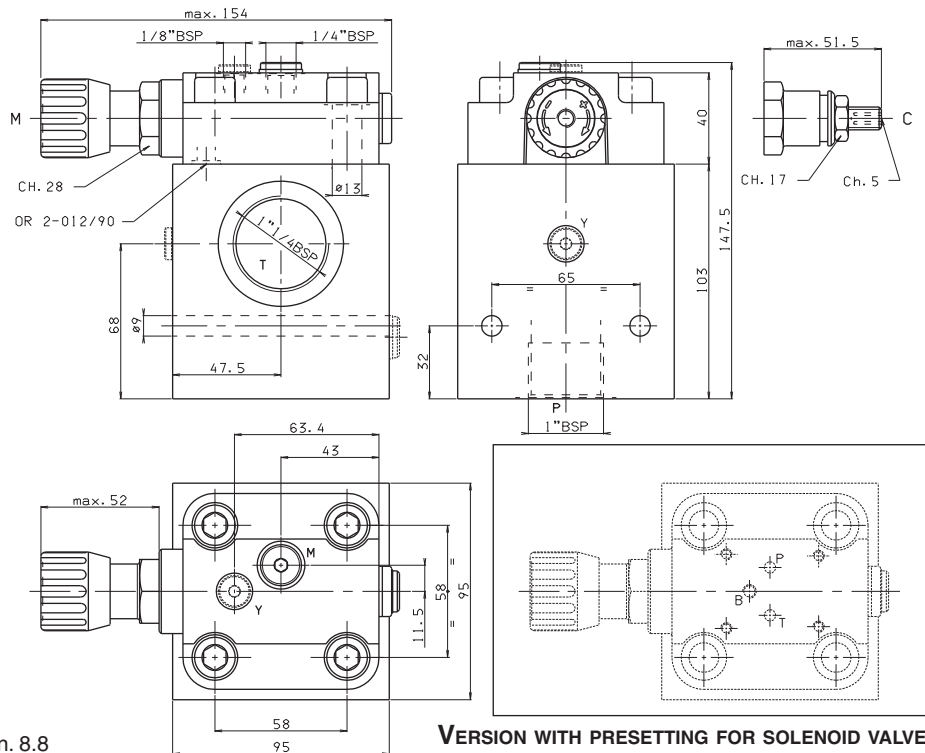

Fixing screws UNI 5931  
M8x110 with material specifications min. 8.8  
Tightening torque 24 Nm / 2.4 Kgm

M = 1/4" BSP connector for pressure gauge for maximum pressure valve version only  
Y = 1/8" BSP external draining for sequencing valve version only

VERSION WITH PRESETTING FOR SOLENOID VALVE

## OVERALL DIMENSIONS V\*L251...

1 1/4" BSP P connector  
1 1/2" BSPT connector

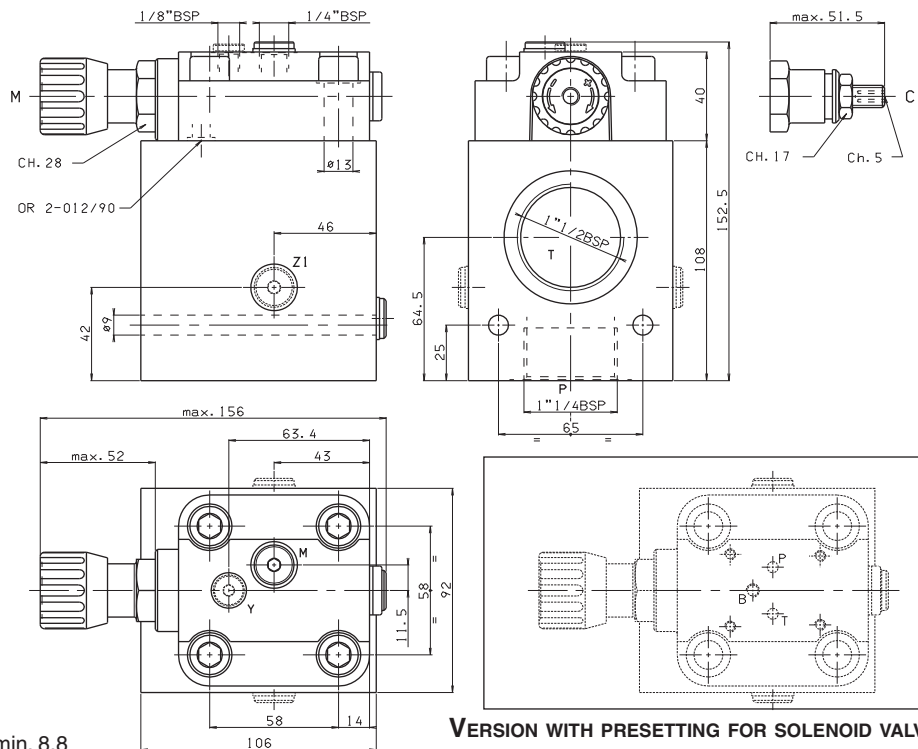

Fixing screws UNI 5931  
M8x120 with material specifications min. 8.8  
Tightening torque 24 Nm / 2.4 Kgm

M = 1/4" BSP connector for pressure gauge for maximum pressure valve version only  
Y = 1/8" BSP external draining for sequencing valve version only

VERSION WITH PRESETTING FOR SOLENOID VALVE

# BSVMP... SUBPLATE MOUNTING FOR V\*P

**BSVMP16... CONNECTORS: P = 1/2" BSP - T = 3/4" BSP - X = 1/4" BSP**

- BS** Single plate
- VMP** Maximum pressure
- 16** Size NG16
- 00** No variant
- 1** Serial No.

Weight: 2,2 Kg  
Fixing screws M8x45 UNI 5931

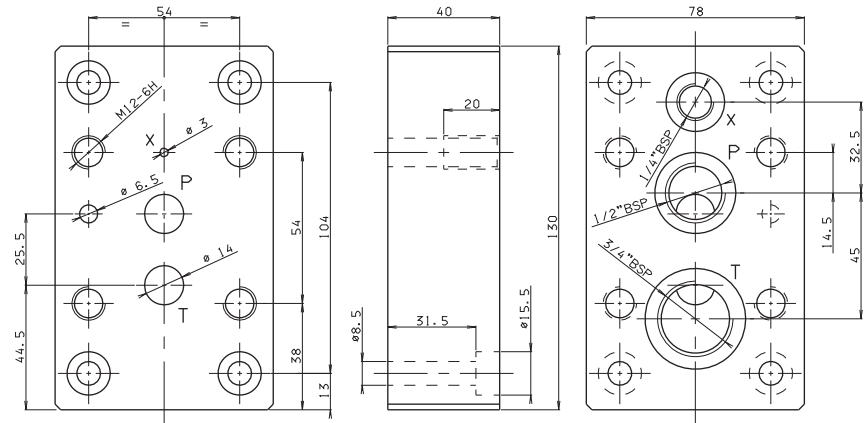

**2**

**BSVMP25... CONNECTORS: P AND T = 3/4" BSP - X = 1/4" BSP**

- BS** Single plate
- VMP** maximum pressure
- 25** Size NG25
- 00** No variant
- 1** Serial No.

Weight: 3,6 Kg  
Fixing screws M12x35 UNI 5931

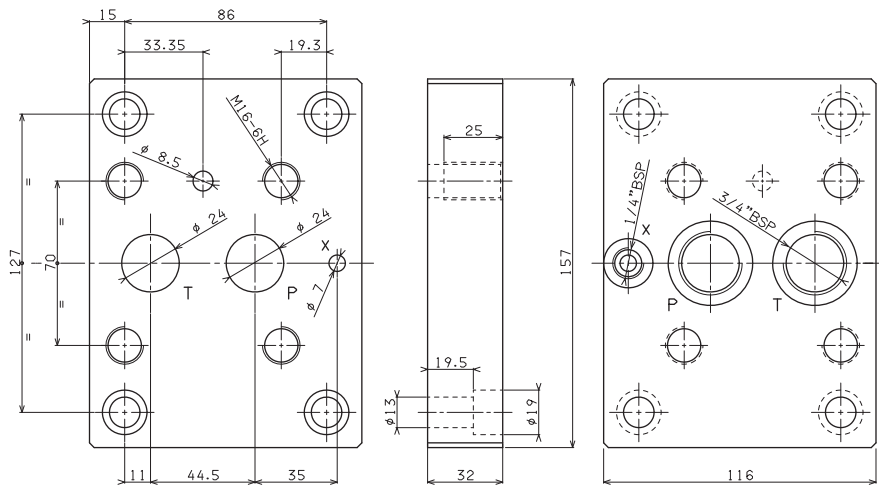

**BSVMP25/1... CONNECTORS: P AND T = 1" BSP - X = 1/4" BSP**

- BS** Single plate
- VMP** maximum pressure
- 25/1** Size NG25
- 00** No variant
- 1** Serial No.

Weight: 4,2 Kg  
Fixing screws M10x45 UNI 5931

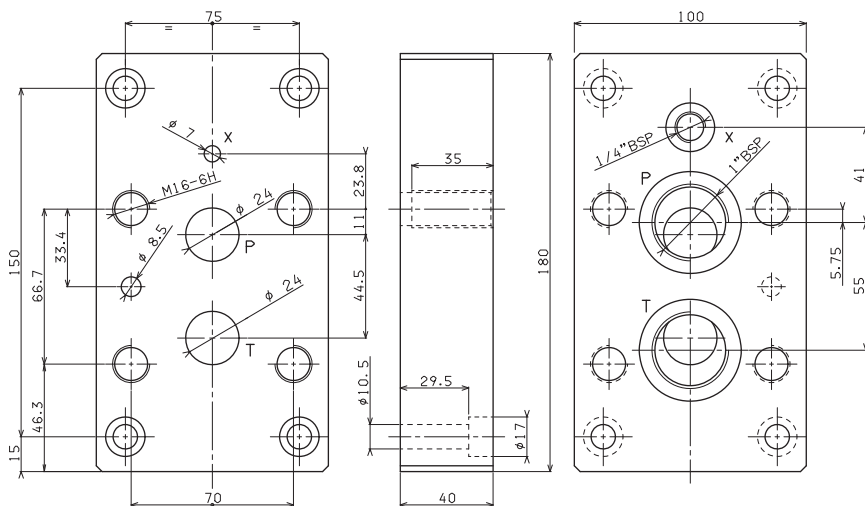





## ABBREVIATIONS

<b>AP</b>	HIGH PRESSURE CONNECTION
<b>AS</b>	PHASE LAG (DEGREES)
<b>BP</b>	LOW PRESSURE CONNECTION
<b>C</b>	STROKE (MM)
<b>CH</b>	ACROSS FLATS
<b>Ch</b>	INTERNAL ACROSS FLATS
<b>DA</b>	AMPLITUDE DECAY (dB)
<b>DP</b>	DIFFERENTIAL PRESSURE (BAR)
<b>F</b>	FORCE (N)
<b>I%</b>	INPUT CURRENT (A)
<b>M</b>	MANOMETER CONNECTION
<b>NG</b>	KNOB TURNS
<b>OR</b>	SEAL RING
<b>P</b>	LOAD PRESSURE (BAR)
<b>PARBAK</b>	PARBAK RING
<b>PL</b>	PARALLEL CONNECTION
<b>Pr</b>	REDUCED PRESSURE (BAR)
<b>Q</b>	FLOW (L/MIN)
<b>QP</b>	PUMP FLOW (L/MIN)
<b>SE</b>	ELASTIC PIN
<b>SF</b>	BALL
<b>SR</b>	SERIES CONNECTION
<b>X</b>	PILOTING
<b>Y</b>	DRAINAGE

## COMPENSATED FLOW REGULATORS



QC32...	CAP. III • 2
QC33...	CAP. III • 3
QCV32	CAP. III • 5

3

## CHECK VALVE HOLDER FOR REGULATORS



AM3ABU...	CAP. III • 4
-----------	--------------



QC32...

DIMENSIONS

CAP. III • 4

## QC32... 2 WAY COMPENSATED FLOW RATE REGULATORS

These QC32... compensated flow rate regulators are designed to control and maintain a constant irrespective of the pressure variations upstream and downstream of the regulation section. Their new cast construction has made it possible to obtain a wider flow rate range, taking the upper limit to 35 l/min (4 turns version) while maintaining unchanged the pressure differential required to obtain good pressure compensation.

All models are available with and without reverse flow check valve, complete with an "anti-jump" device on request. This accessory has been designed to eliminate the problem which manifests itself as a "anti-jump" in the controlled actuator due to the instantaneous flow rate variation that takes place under the form of a transient every time the flow is made to pass through the regulator.

Max. operating pressure	320 bar
Opening pressure (with bypass)	1 bar
Min. regulated flow rate (Q1 version)	0.03 ÷ 0.05 l/min
Nominal regulated flow rate (1 turn version)	1,5 ÷ 30 l/min
Nominal regulated flow rate (4 turns version)	1,5 ÷ 35 l/min
Difference in pressure ( $\Delta p$ ) for vers. Q1	3 bar
Difference in pressure ( $\Delta p$ ) Q2-Q3-Q4-Q5-Q6	8 bar
Hydraulic fluids	Mineral oils DIN 51524
Fluid viscosity	10 ÷ 500 mm <sup>2</sup> /s
Fluid temperature	-25°C ÷ 75°C
Ambient temperature	-25°C ÷ 60°C
Max. contamination level(*)	class 10 in accordance with NAS 1638 with filter $\beta_{25} \geq 75$
Dependency on temperature (Q1 vers.)	5%
Dependency on temperature (Q2 vers.)	3%
Dependency on temperature (Q3-Q4-Q5-Q6)	2%
Weight	1,5 Kg

(\*) Max contamination level must be respect to obtain the right function of the valve

### ORDERING CODE

**QC** Compensated flow rate regulated

**3** CETOP 3/NG6

**2** 2 way

**G** Anti-jump system with internal check valve (omit if not required)

**\*\*** Nominal flow rate ranges  
**1 Turn version 4 Turn version**  
**Q1** = 1,5 l/min **Q1** = 1,5 l/min  
**Q2** = 3 l/min **Q2** = 4 l/min  
**Q3** = 9 l/min **Q3** = 10 l/min  
**Q4** = 19 l/min **Q4** = 21 l/min  
**Q5** = 24 l/min **Q5** = 28 l/min  
**Q6** = 30 l/min **Q6** = 35 l/min

**K** Version with lock (omit if not required)

**\*** **1** = 1 turn version  
**4** = 4 turns version

**R** With internal check valve (omit if not required)

**\*\*** **00** = No variant  
**V1** = Viton

**5** Serial No.

### HYDRAULIC SYMBOLS

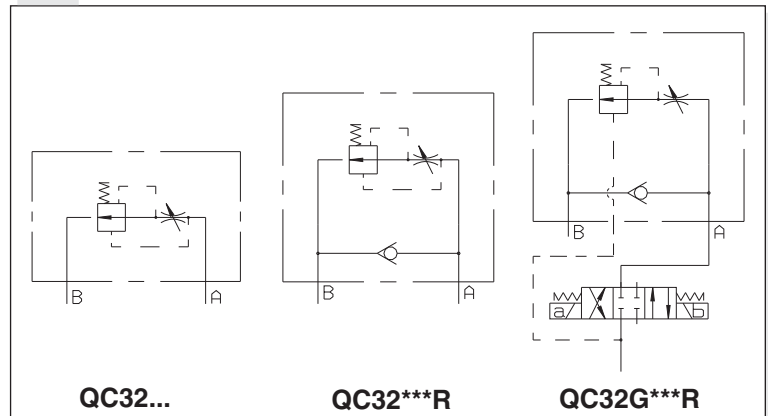

### DIAGRAMS

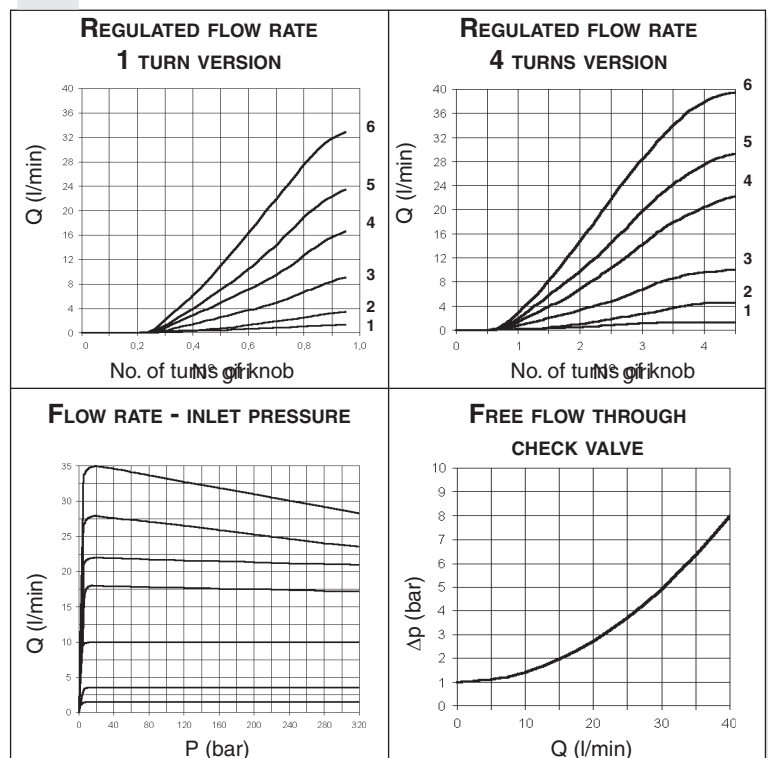

## QC33... 3 WAY COMPENSATED FLOW RATE REGULATORS



**QC33...**

OVERALL DIMENSIONS	CAP. III • 4
AM3ABU...	CAP. III • 4

This regulator type can be used whenever it is necessary to obtain a constant fluid flow irrespective of the pressure variations present upstream or downstream. It is fitted with a third T line for discharging any excessive flow rate.

When the reverse flow check valve is needed, the check valve holder type "AM3ABU3..." can be fitted underneath the valve. (The check valve holder must be ordered separately see next page).

Max. operating pressure	320 bar
Opening pressure (with bypass)	1 bar
Min. regulated flow rate (Q1 version)	0.03 ÷ 0.05 l/min
Nominal regulated flow rate	1 ÷ 22 l/min
Difference in pressure ( $\Delta p$ ) for vers. Q1	3 bar
Difference in pressure ( $\Delta p$ ) Q2-Q3-Q4-Q5-Q6	8 bar
Hydraulic fluids	Mineral oils DIN 51524
Fluid viscosity	10 ÷ 500 mm <sup>2</sup> /s
Fluid temperature	-25°C ÷ 75°C
Ambient temperature	-25°C ÷ 60°C
Max. contamination level(*)	class 10 in accordance with NAS 1638 with filter $\beta_{25} \geq 75$
Dependency on temperature (Q1 vers.)	5%
Dependency on temperature (Q2 vers.)	3%
Dependency on temperature (Q3-Q4-Q5)	2%
Weight	1,5 Kg
(*) Max contamination level must be respect to obtain the right function of the valve	

### ORDERING CODE

<b>QC</b>	Compensated flow rate regulator
<b>3</b>	CETOP 3/NG6
<b>3</b>	3 way
<b>**</b>	Flow rate ranges <b>Q1</b> = 1 l/min <b>Q2</b> = 3 l/min <b>Q3</b> = 9 l/min <b>Q4</b> = 17 l/min <b>Q5</b> = 24 l/min
<b>K</b>	Version with lock (omit if not required)
<b>*</b>	<b>1</b> = 1 turn version <b>4</b> = 4 turns version
<b>**</b>	<b>00</b> = No variant <b>V1</b> = Viton
<b>3</b>	Serial No.

### HYDRAULIC SYMBOLS

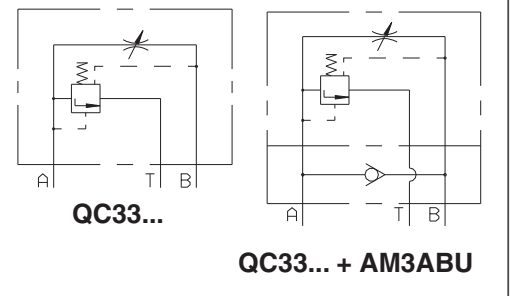

### DIAGRAMS

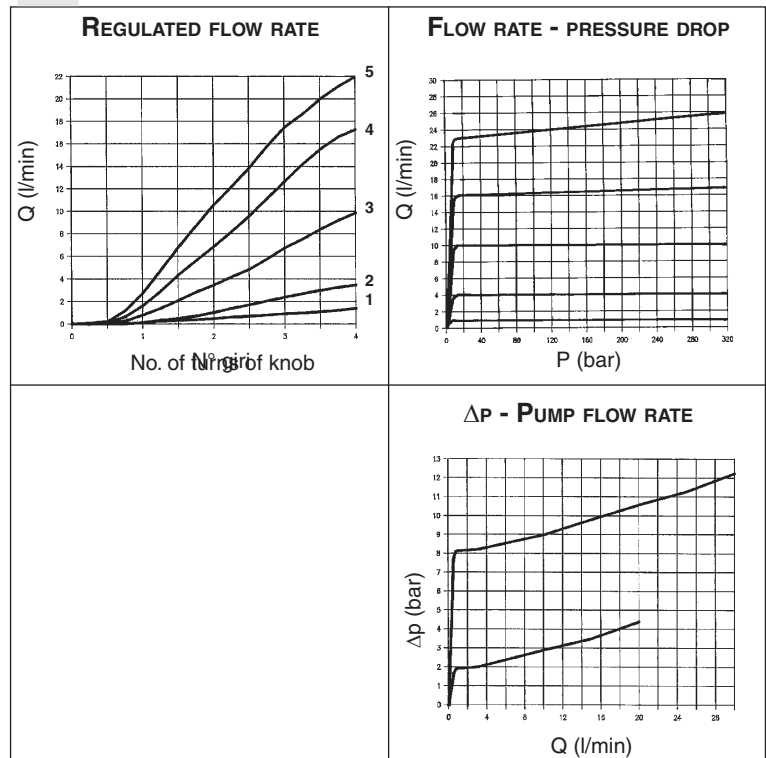

# QC32... QC33... COMPENSATED FLOW RATE REGULATORS

3

## QC32... 2 WAY FLOW RATE REGULATOR

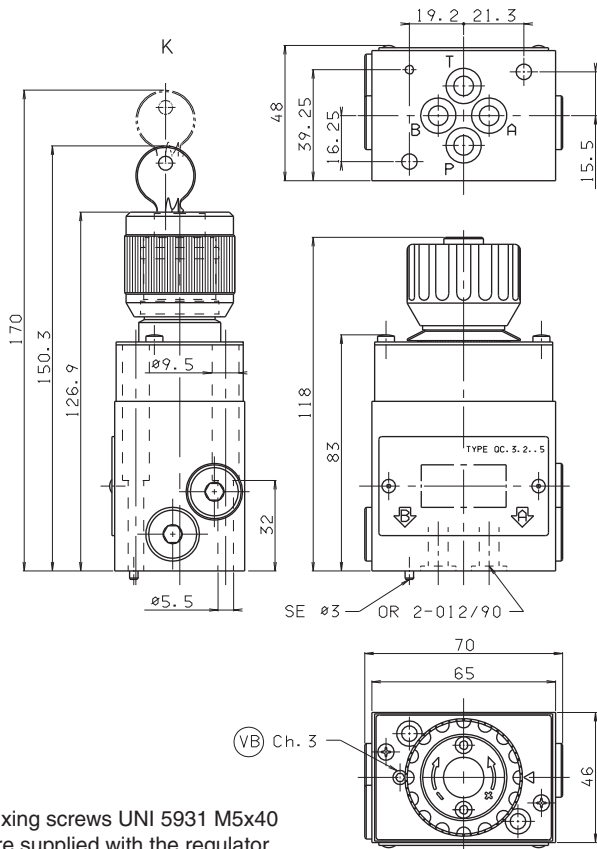

Fixing screws UNI 5931 M5x40 are supplied with the regulator, material specifications min. 12.9  
Tightening torque 6.5÷7 Nm / 0.65÷0.70 Kgm

## QC33... 3 WAY FLOW RATE REGULATOR

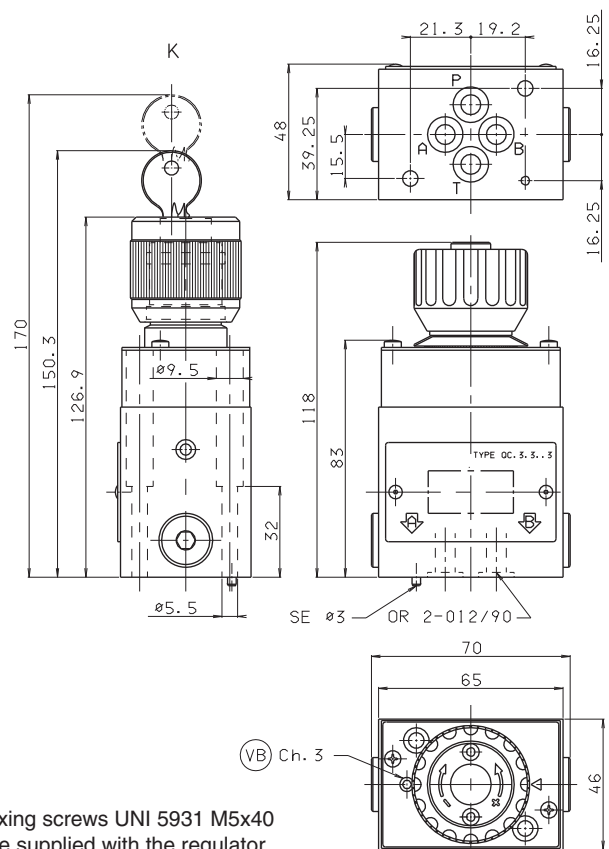

Fixing screws UNI 5931 M5x40 are supplied with the regulator, material specifications min. 12.9  
Tightening torque 6.5÷7 Nm / 0.65÷0.70 Kgm

## AM3ABU... CHECK VALVE HOLDER FOR REGULATORS TYPE QC3...



This check valve holder must be fitted underneath the QC valve when the reverse flow function is needed.

### ORDERING CODE

<b>AM</b>	Modulating valve
<b>3</b>	CETOP 3/NG06
<b>ABU</b>	External check valve for QC3*.
<b>3</b>	For 2 way and 3 way
<b>00</b>	No variant
<b>1</b>	Serial No.

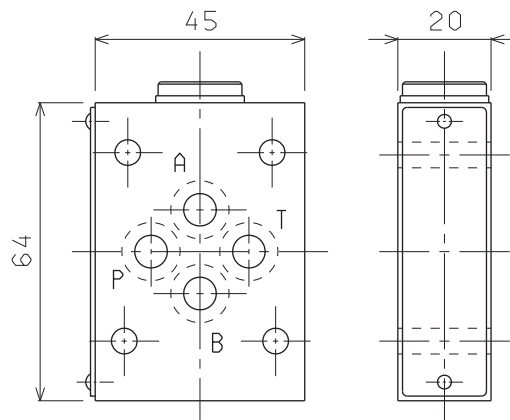

Weight: 0,4 Kg  
Fixing screws for regulator and modular check valve M5x60 UNI 5931 - 12.9 K

## QCV32... 2 WAY COMPENSATED FLOW RATE REGULATORS WITH ADJUSTABLE $\Delta p$



QCV32...

Compensated flow regulators with antijump system and adjustable differential pressure can be defined as hydraulic power control units. Their design is suitable to circuits in which the flow rate has to be automatically operated as a function of the actuator working pressure.

For application requirements, please contact our technical service that can help you to choose the right valve and use it properly.

Max. operating pressure	320 bar
Nominal regulated flow rate	1 ÷ 24 l/min
Hydraulic fluids	Mineral oils DIN 51524
Fluid temperature	-25°C ÷ 75°C
Ambient temperature	-25°C ÷ 60°C
Fluid viscosity	10 ÷ 500 mm <sup>2</sup> /s
Max. contamination level(*)	class 10 in accordance with NAS 1638 with filter $\beta_{25} \geq 75$
Weight	1.5 Kg

(\*) Max contamination level must be respect to obtain the right function of the valve

### ORDERING CODE

**QCV**

Compensated flow rate regulated with adjustable  $\Delta p$

**3**

CETOP 3/NG06

**2G**

Pre-setting for external operating

**\*\***

Flow rate ranges

**Q1** = 1.5 l/min

**Q2** = 3 l/min

**Q3** = 9 l/min

**Q4** = 19 l/min

**Q5** = 24 l/min

**\***

**1** = 1 turn version

**4** = 4 turns version

**R**

Internal check valve  
(omit if not required)

**\*\***

**00** = No variants

**V1** = Viton

**FS** = Sintered filters (Q1/Q2 only)

**KK** = Version with tightening key

**5**

Serial No

### HYDRAULIC SYMBOL

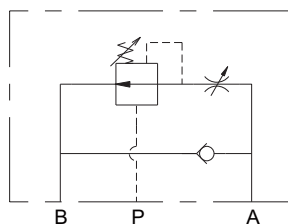

### OVERALL DIMENSIONS

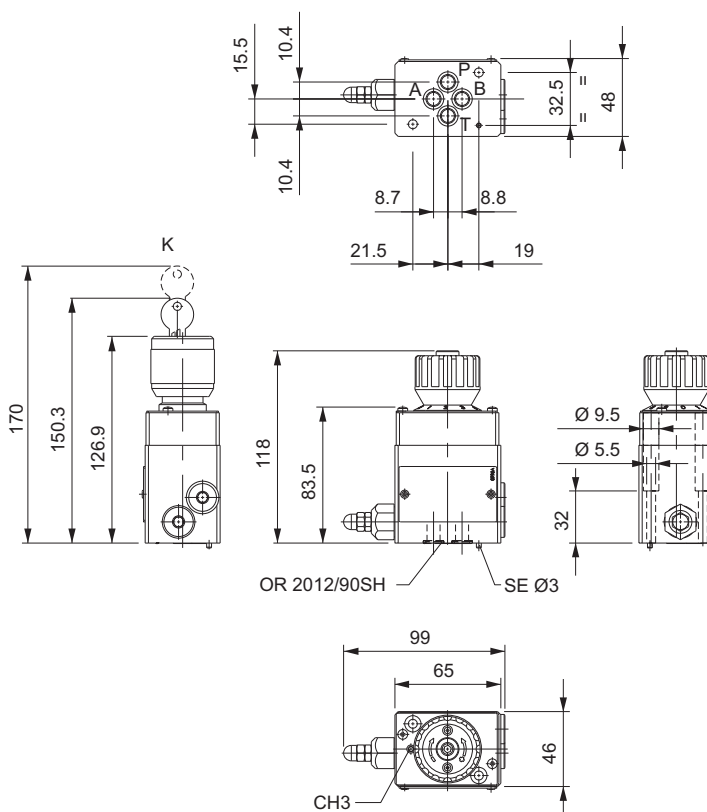

Fixing screws UNI 5931 M5x40 are supplied with the regulator, material specifications min. 12.9  
Tightening torque 6.5÷7 Nm / 0.65÷0.70 Kgm

Support plane specifications

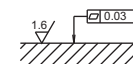



# MODULAR VALVES

## ABBREVIATIONS

AP	HIGH PRESSURE CONNECTION
AS	PHASE LAG (DEGREES)
BP	LOW PRESSURE CONNECTION
C	STROKE (MM)
CH	ACROSS FLATS
Ch	INTERNAL ACROSS FLATS
DA	AMPLITUDE DECAY (dB)
DP	DIFFERENTIAL PRESSURE (BAR)
F	FORCE (N)
I%	INPUT CURRENT (A)
M	MANOMETER CONNECTION
NG	KNOB TURNS
OR	SEAL RING
P	LOAD PRESSURE (BAR)
PARBAK	PARBAK RING
PL	PARALLEL CONNECTION
Pr	REDUCED PRESSURE (BAR)
Q	FLOW (L/MIN)
QP	PUMP FLOW (L/MIN)
SE	ELASTIC PIN
SF	BALL
SR	SERIES CONNECTION
X	PILOTING
Y	DRAINAGE

## MODULAR VALVES CETOP 2



AM2UD...	CAP. IV • 2
AM2UP...	CAP. IV • 3
AM2VM...	CAP. IV • 4
AM2QF...	CAP. IV • 5
SCREWS AND STUDS	CAP. IV • 6

## MODULAR VALVES CETOP 5



AM5UD...	CAP. IV • 22
AM5UP...	CAP. IV • 23
AM5VM... / AM5VI...	CAP. IV • 24
AM5CP...	CAP. IV • 26
AM5VR...	CAP. IV • 27
AM5VS...	CAP. IV • 29
AM5SH...	CAP. IV • 30
AM5QF...	CAP. IV • 31
AM88...	CAP. IV • 33
A88...	CAP. IV • 34
AM5RGT...	CAP. IV • 36
SCREWS AND STUDS	CAP. IV • 36

## MODULAR VALVES CETOP 3



AM3UD...	CAP. IV • 7
AM3UP / AM3UP1	CAP. IV • 8
AM3VM... / AM3VI...	CAP. IV • 9
AM3CP...	CAP. IV • 11
AM3RD... / AM3SD...	CAP. IV • 12
AM3VR...	CAP. IV • 13
AM3VS...	CAP. IV • 15
AM3SH...	CAP. IV • 16
AM3QF...	CAP. IV • 17
AM66...	CAP. IV • 18
A66...	CAP. IV • 19
AM3RGT...	CAP. IV • 20
SCREWS AND STUDS	CAP. IV • 21

## MODULAR VALVES CETOP 7



AM7UP...	CAP. IV • 37
AM7QF...	CAP. IV • 38

4



AM2UD...

SCREWS AND STUDS

CAP. IV • 6

## AM2UD... MODULAR DIRECT CHECK VALVES CETOP 2

AM.2.UD type modular check valves allow one way free flow, while preventing any flow in the opposite direction by means of a conical seated poppet.

They are available on single P and T lines (see hydraulic symbols).

1 bar spring is standard, while a 5 bar rated spring is available on request.

Max. operating pressure	250 bar
Minimum opening pressure spring 1	1 bar
Minimum opening pressure spring 5	5 bar
Max. flow	20 l/min
Hydraulic fluids	Mineral oils DIN 51524
Fluid viscosity	10 ÷ 500 mm <sup>2</sup> /s a 50°C
Fluid temperature	-20°C ÷ 75°C
Max. contamination level	class 10 in accordance with NAS 1638 with filter $\beta_{25} \geq 75$
Weight	0,4 Kg

4

### ORDERING CODE

<b>AM</b>	Modular valve
<b>2</b>	CETOP 2/NG4
<b>UD</b>	Direct check valve
<b>*</b>	Control on lines <b>P / T</b>
<b>*</b>	Minimum opening pressure <b>1</b> = 1 bar <b>5</b> = 5 bar
<b>**</b>	<b>00</b> = No variant <b>V1</b> = Viton
<b>1</b>	Serial No.

### HYDRAULIC SYMBOLS

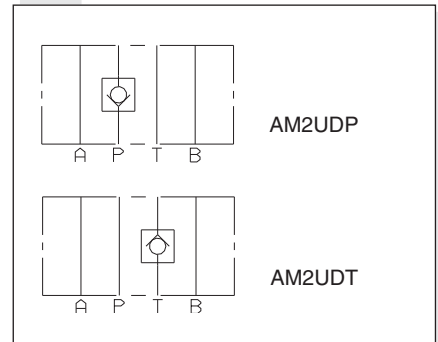

### PRESSURE DROPS

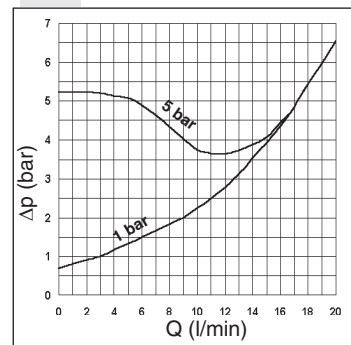

### OVERALL DIMENSIONS

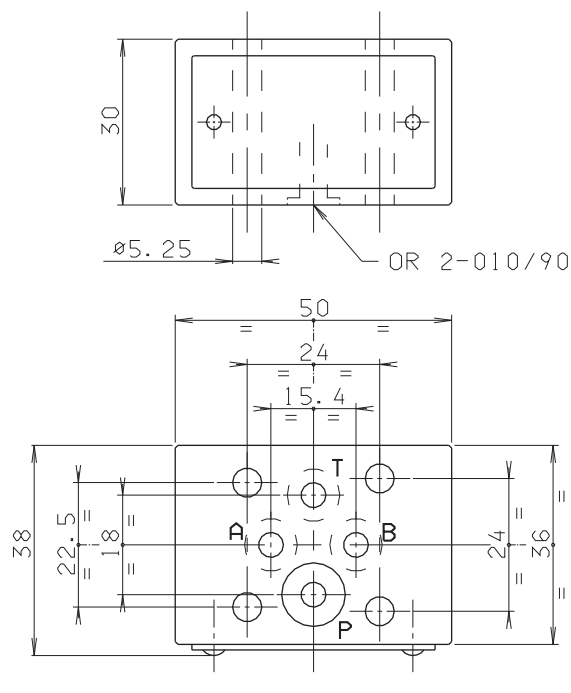

Support plane specifications

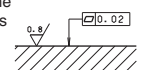





**AM2UP...**

SCREWS AND STUDS

CAP. IV • 6

**AM2UP... MODULAR PILOT OPERATED CHECK VALVES CETOP 2**

AM.2.UP type modular check valves allow one way free flow by raising a conical shutter, while in the opposite direction the fluid can return by means of a small piston piloted by the pressure in the other line.

They are available on single A or B lines, and on double A and B lines (see hydraulic symbols ).

Max. operating pressure	250 bar
Minimum opening pressure spring 1	1 bar
Minimum opening pressure spring 5	5 bar
Piloting ratio:	1:4
Max. flow	20 l/min
Hydraulic fluids	Mineral oils DIN 51524
Fluid viscosity	10 ÷ 500 mm <sup>2</sup> /s a 50°C
Fluid temperature	-20°C ÷ 75°C
Max. contamination level	class 10 in accordance with NAS 1638 with filter $\beta_{25} \geq 75$
Weight	0,5 Kg

**ORDERING CODE**

- AM** Modular valve
- 2** CETOP 2/NG4
- UP** Piloted check valve
- \*\*** Control on lines **A / B / AB**
- \*** Minimum opening pressure  
1 = 1 bar  
5 = 5 bar
- \*\*** 00 = No variant  
V1 = Viton
- 1** Serial No.

**PRESSURE DROPS**

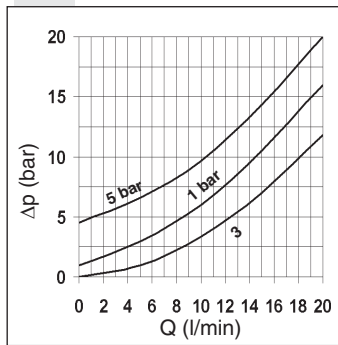

Curve n. 3 = Piloted side flow

**HYDRAULIC SYMBOLS**

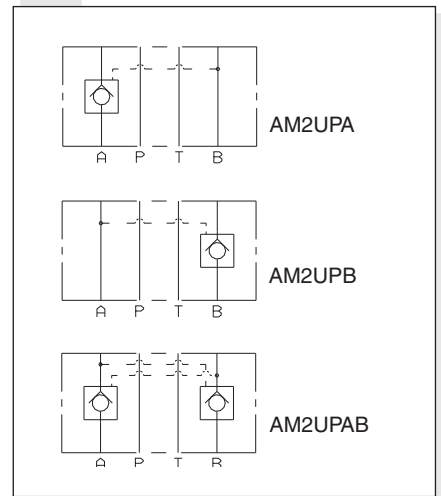

**4**

**OVERALL DIMENSIONS**

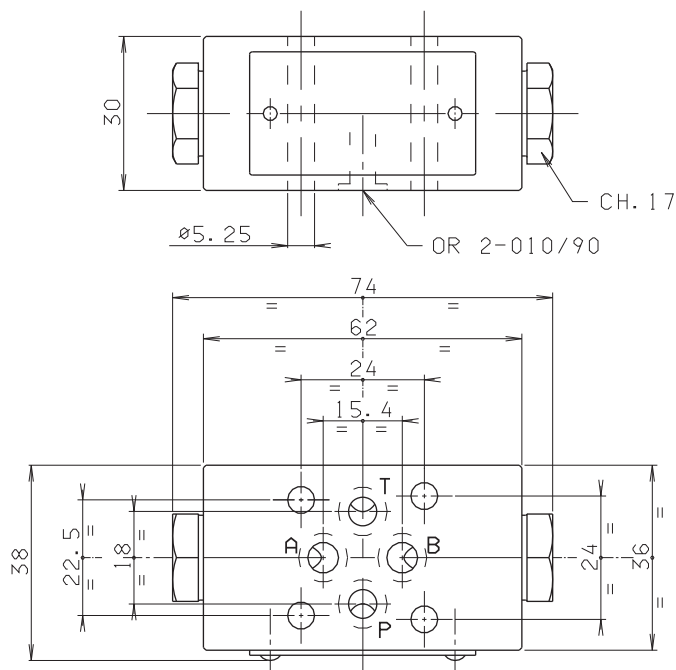

Support plane specifications

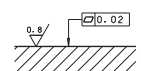

# AM2VM... MODULAR MAXIMUM PRESSURE VALVES CETOP 2

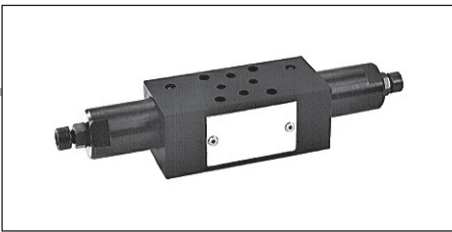

<b>AM2VM...</b>	
CMP02...	CARTRIDGE CATALOGUE
SCREWS AND STUDS	CAP. IV • 6

AM.2.VM type pressure regulating valves are available with an operating pressure range of 4 to 250 bar. Adjustment is via a grub screw. Two base versions are available: **AM2VM..** single on A or B, and double on A and B lines, with drainage on T; **AM2VMP..** single on P line, with drainage on T. 4 different types of springs can be mounted on all versions, with the adjustment range specified in the specifications. The cartridge used is the CMP02 type.

Max. operating pressure	250 bar	
Setting ranges:	spring 1	30 bar
	spring 2	90 bar
	spring 3	180 bar
	spring 4	250 bar
Max. flow	20 l/min	
Hydraulic fluids	Mineral oils DIN 51524	
Fluid viscosity	10 ÷ 500 mm <sup>2</sup> /s a 50°C	
Fluid temperature	-20°C ÷ 75°C	
Max. contamination level	class 10 in accordance with NAS 1638 with filter $\beta_{25} \geq 75$	
Weight AM2VMA/B/P...	0,53 Kg	
Weight AM2VMAB...	0,7 Kg	

## ORDERING CODE

<b>AM</b>	Modular valve
<b>2</b>	CETOP 2/NG4
<b>VM</b>	Max. pressure valves
<b>**</b>	Adjustment on the lines <b>A / B / P / AB</b>
<b>C</b>	Type of adjustment grub screw
<b>*</b>	Setting ranges at port A/B/P <b>1 = max.30 bar (white spring)</b> <b>2 = max.90 bar (yellow spring)</b> <b>3 = max.180 bar (green spring)</b> <b>4 = max.250 bar (orange spring)</b>
<b>*</b>	Setting ranges at port B (Omit if the setting is same as that at port A) <b>1 = max.30 bar (white spring)</b> <b>2 = max.90 bar (yellow spring)</b> <b>3 = max.180 bar (green spring)</b> <b>4 = max.250 bar (orange spring)</b>
<b>**</b>	<b>00</b> = No variant <b>V1</b> = Viton
<b>1</b>	Serial No.

## PRESSURE - FLOW RATE

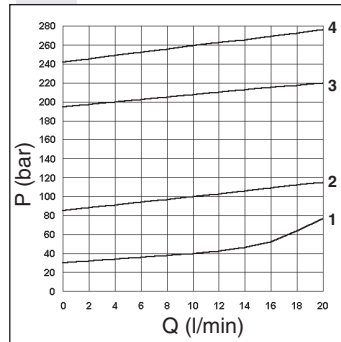

## MINIMUM SETTING PRESSURE

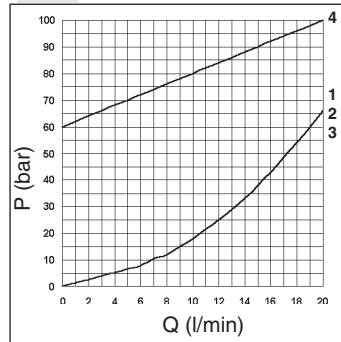

## HYDRAULIC SYMBOLS

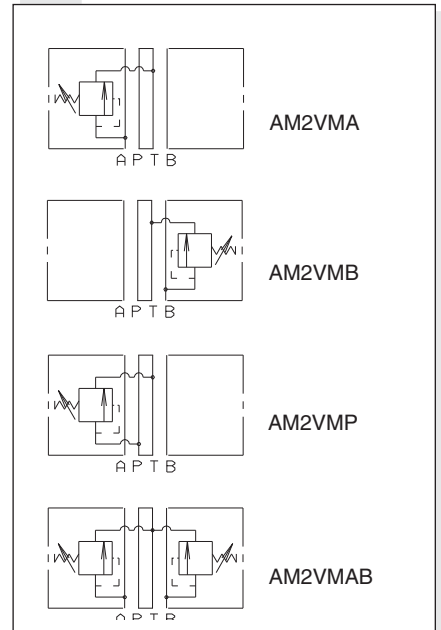

## OVERALL DIMENSIONS

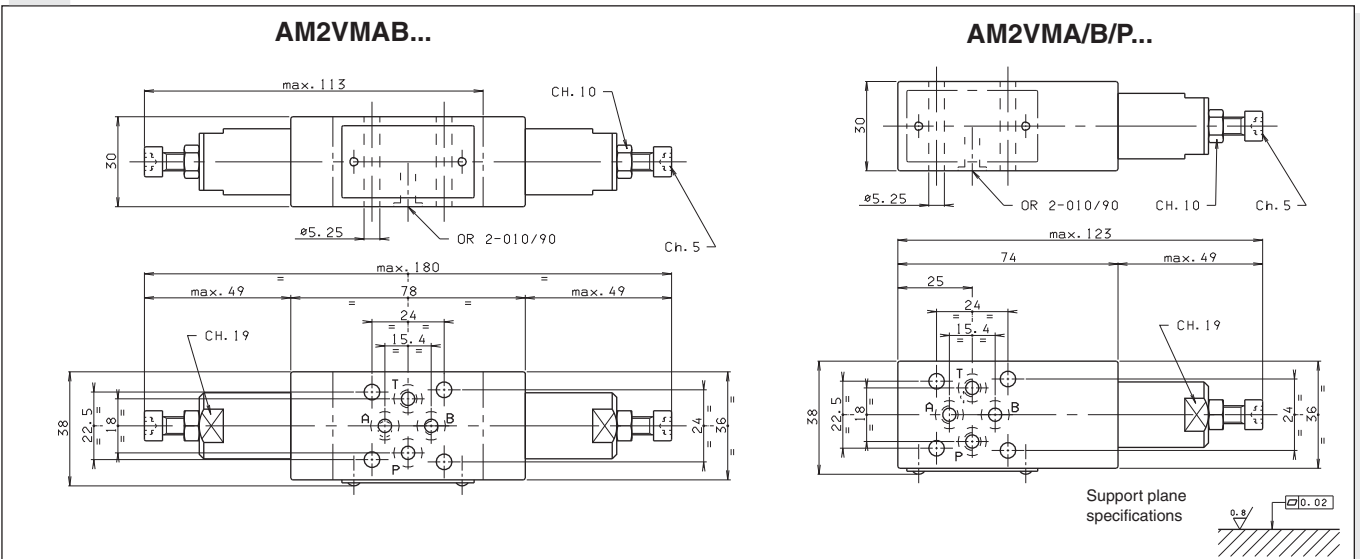

# AM2QF... MODULAR FLOW REGULATOR CETOP 2



AM2QF...

SCREWS AND STUDS

CAP. IV • 6

AM2QF type one way non-compensated throttle valves are adjustable by means of a grub screw.

Three types of regulations are available on A / B / AB lines, as shown in the hydraulic symbols.

Max. operating pressure	250 bar
Flow rate regulation	on 6 screw turns
Max. flow.	20 l/min
Hydraulic fluids	Mineral oils DIN 51524
Fluid viscosity	10 ÷ 500 mm <sup>2</sup> /s a 50°C
Fluid temperature	-20°C ÷ 75°C
Max. contamination level	class 10 in accordance with NAS 1638 with filter $\beta_{25} \geq 75$
Weight AM2QFA/B...	0,5 Kg
Weight AM2QFAB...	0,6 Kg

### ORDERING CODE

<b>AM</b>	Modular valve
<b>2</b>	CETOP 2/NG4
<b>QF</b>	Non-compensated flow rate regulator
<b>**</b>	Control on lines <b>A / B / AB</b>
<b>C</b>	Type of adjustment grub screw
<b>**</b>	<b>00</b> = No variant <b>V1</b> = Viton
<b>1</b>	Serial No.

### FLOW REGULATION

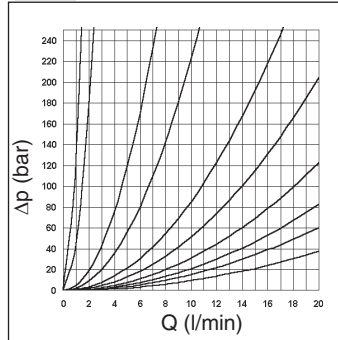

### FREE FLOW THROUGH CHECK VALVE

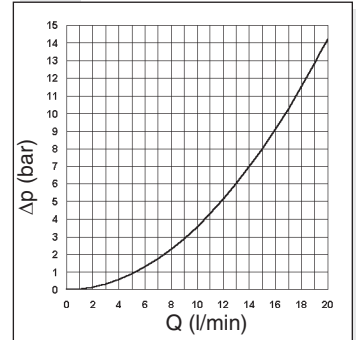

### HYDRAULIC SYMBOLS

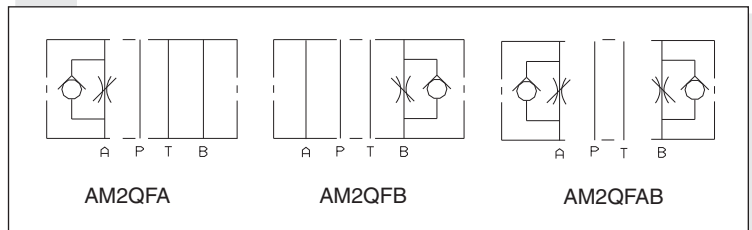

### OVERALL DIMENSIONS

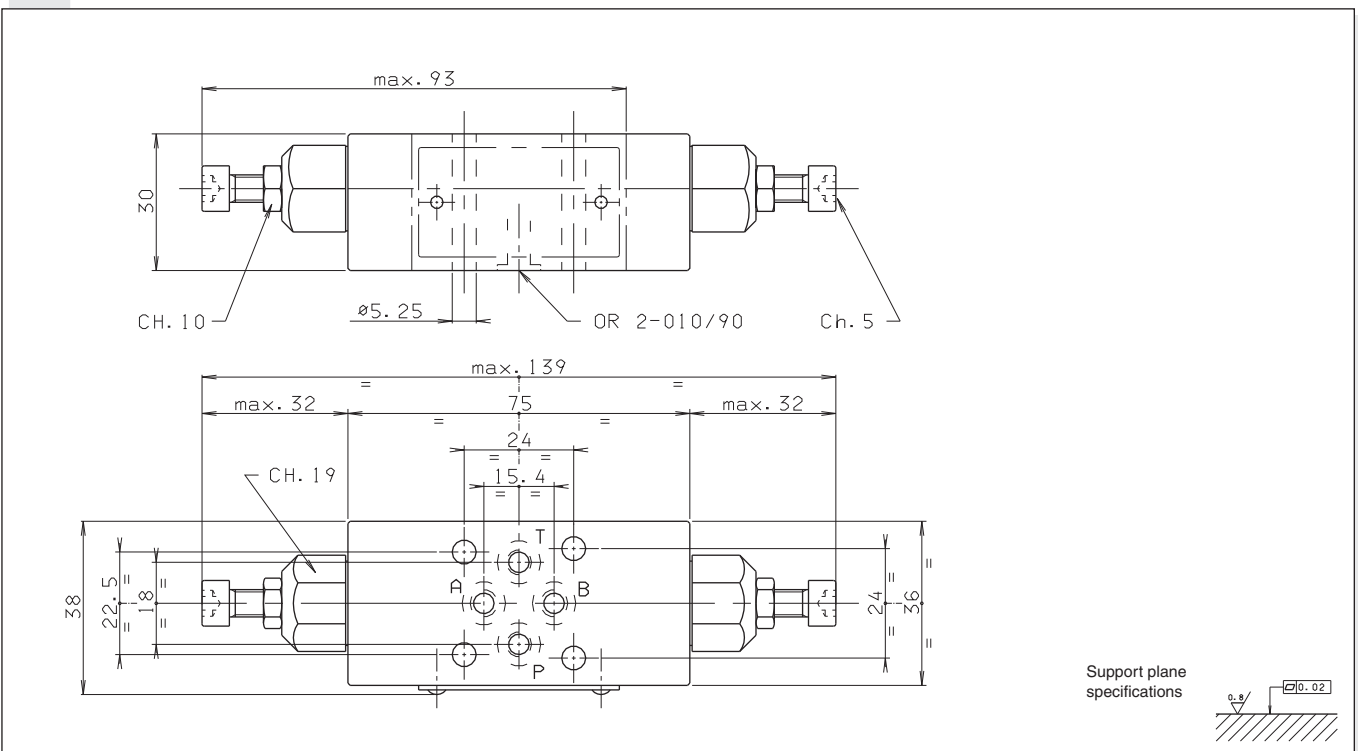

# TABLE OF SCREWS AND STUDS FOR MOUNTING MODULES CETOP 2

## OVERALL DIMENSIONS

Tighten M27.05.0001 to a torque of 5 Nm / 0.5 Kgm max.

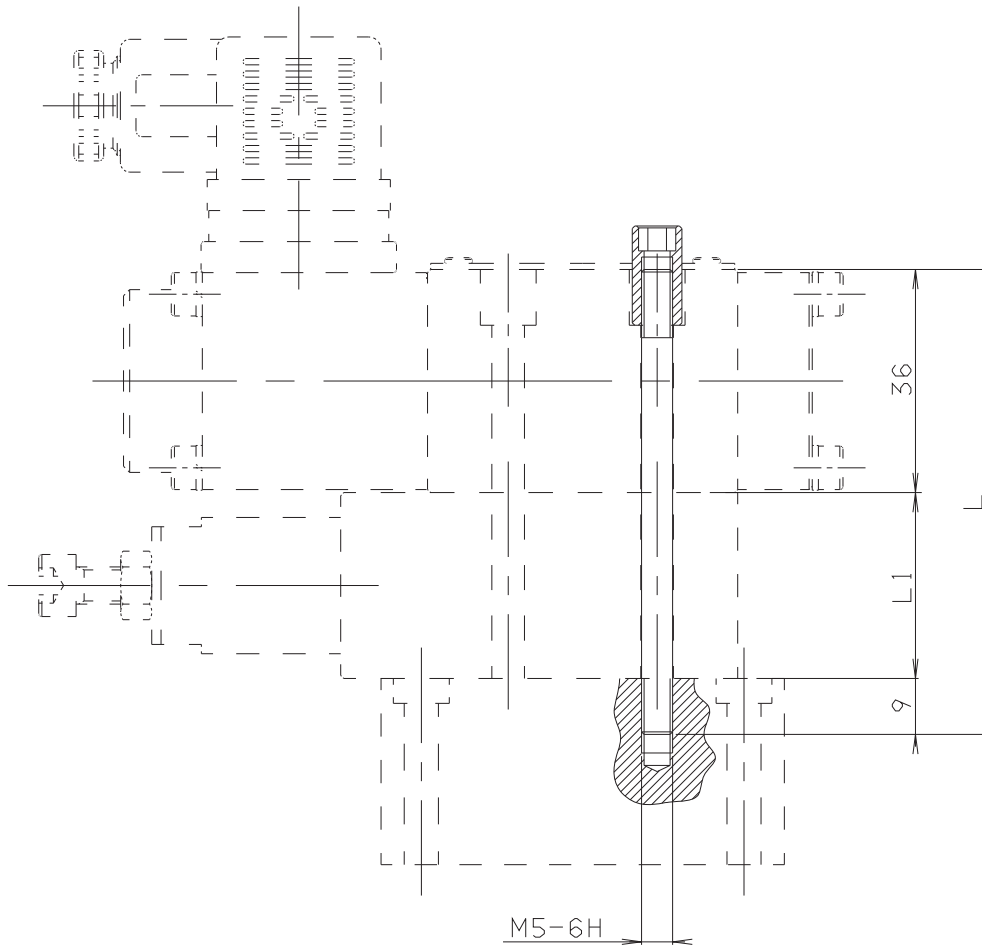

4

SCREWS T.C.E.I CODE	L mm	L1* mm	COMPOSITION	Q.TY	SPECIAL NUTS CODE
Q26074069	35	—	AD2...	4	—
Q26074243	65	30	AD2... + 1 AM2... (ISO)	4	
Q26074252	95	60	AD2... + 2 AM2... (ISO)	4	
M80100008	135	90	AD2... + 3 AM2...	4	V89240000 (No. 20 nuts kit)
M80100020	165	120	AD2... + 4 AM2...	4	

\* Indicative overall dimensions valves composition



**AM3UD...**

SCREWS AND STUDS

CAP. IV • 21

# AM3UD... MODULAR DIRECT CHECK VALVES CETOP 3

AM.3.UD type modular check valves allow one way free flow, while flow in the opposite direction is prevented by means of a conical seated poppet.

They are available on single A, B, P and T lines, and on double A and B, P and T lines (see hydraulic symbols).

1 bar spring is standard, while a 5 bar rated spring is available on request.

Max. operating pressure	350 bar
Minimum opening pressure spring 1	1 bar
Minimum opening pressure spring 5	5 bar
Max. flow	40 l/min
Hydraulic fluids	Mineral oils DIN 51524
Fluid viscosity	10 ÷ 500 mm <sup>2</sup> /s a 50°
Fluid temperature	-25°C ÷ 75°C
Ambient temperature	-25°C ÷ 60°C
Max. contamination level	class 10 in accordance with NAS 1638 with filter $\beta_{25} \geq 75$
Weight	0,8 Kg

**ORDERING CODE**

- AM** Modular valve
- 3** CETOP 3/NG6
- UD** Direct check valve
- \*\*** Control on lines **A / B / P / T / AB**
- \*** Minimum opening pressure  
1 = 1 bar  
5 = 5 bar
- \*\*** 00 = No variant  
V1 = Viton
- 2** Serial No.

**PRESSURE DROPS**

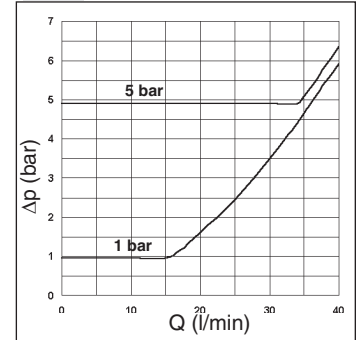

4

**HYDRAULIC SYMBOLS**

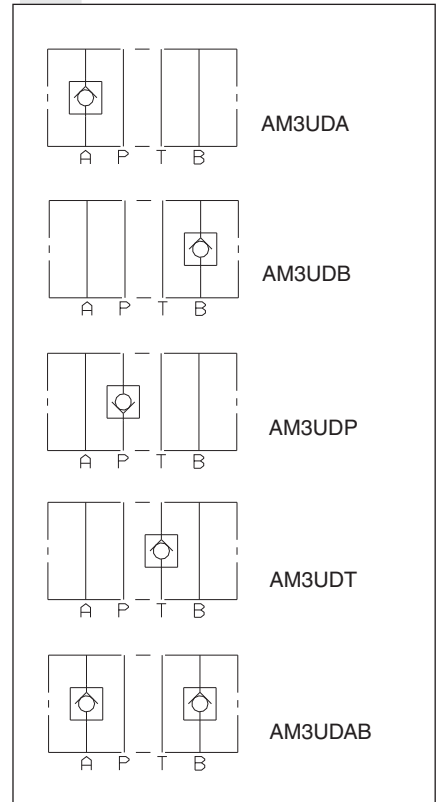

**OVERALL DIMENSIONS**

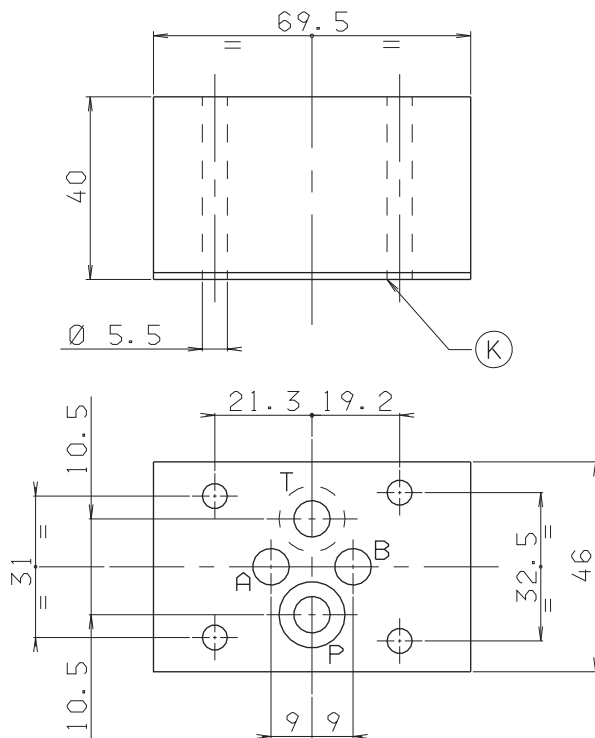

K = OR plate

Support plane specifications

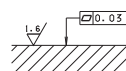

# AM3UP... / AM3UP1... MODULAR PILOT OPERATED CHECK VALVES CETOP 3



**AM3UP / AM3UP1**

SCREWS AND STUDS

CAP. IV • 21

AM.3.UP type modular check valves allow free flow in one direction by raising a conical seated poppet valve, while in the opposite direction the fluid can return by means of a small piston piloted by the other line pressure (piloted side).

They are available on single A or B lines, and double A and B lines (see hydraulic symbols).

A pre-opening version is also available (AM3UP1..) only with 5 bar spring.

Max. operating pressure	350 bar
Minimum opening pressure spring 1	1 bar
Minimum opening pressure spring 5	5 bar
Piloting ratio AM.3.UP	1:4
Piloting ratio AM.3.UP1	1:12,5
Max. flow	40 l/min
Hydraulic fluids	Mineral oils DIN 51524
Fluid viscosity	10 ÷ 500 mm <sup>2</sup> /s
Fluid temperature	-25°C ÷ 75°C
Ambient temperature	-25°C ÷ 60°C
Max. contamination level	class 10 in accordance with NAS 1638 with filter $\beta_{25} \geq 75$
Weight	1 Kg

4

### ORDERING CODE

- AM** Modular valve
- 3** CETOP 3/NG6
- \*\*** **UP** = Piloted check valve  
**UP1** = With pre-opening
- \*\*** Control on lines **A / B / AB**
- \*** Minimum opening pressure  
**1** = 1 bar (only for UP version)  
**5** = 5 bar  
**8** = 8 bar (only for UP version)
- \*\*** **00** = No variant  
**V1** = Viton
- 3** Serial No.

### HYDRAULIC SYMBOLS

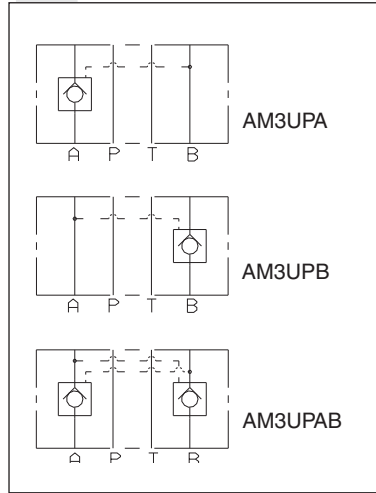

### PRESSURE DROPS AM3UP

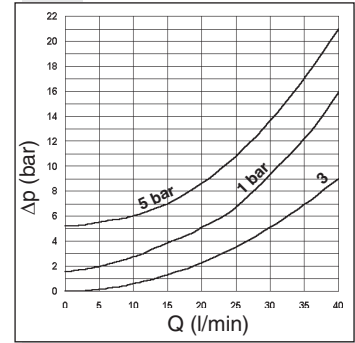

### PRESSURE DROPS AM3UP1

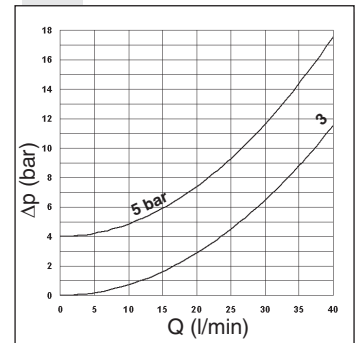

Curve n. 3 = Piloted side flow

The fluid used is a mineral oil with a viscosity of 46 mm<sup>2</sup>/s at 40°C. The tests have been carried out at a fluid temperature of 50°C.

### OVERALL DIMENSIONS

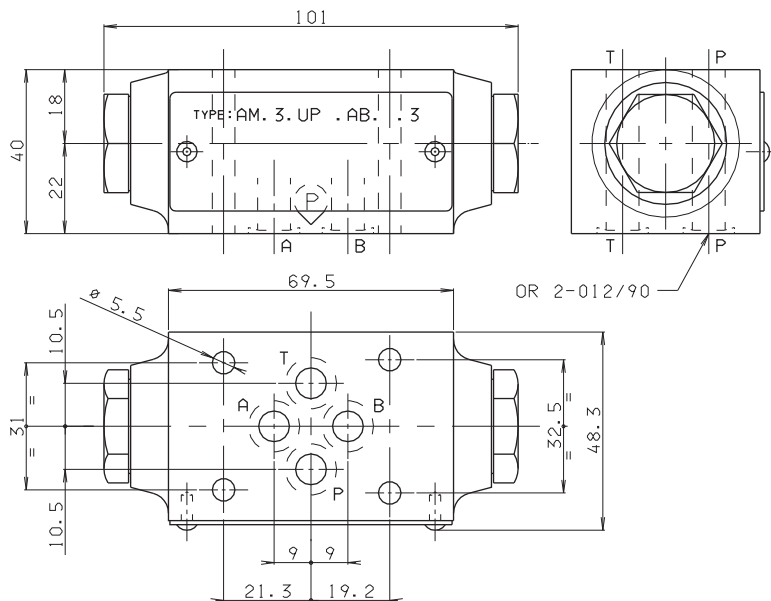

Support plane specifications

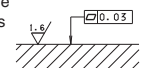

# AM3VM... / AM3VI... MODULAR MAX PRESSURE VALVES CETOP 3



AM3VM...

CMP10... CAP. VII • 30  
SCREWS AND STUDS CAP. IV • 21

AM.3.VM type pressure regulating valves are available with a pressure range of 2 ÷ 320 bar.

Adjustment is by means of a grub screw or a plastic knob.

Three basic versions are available:  
 - AM3VM on single A or B lines, and on A and B lines, with drainage to T;  
 - AM3VMP on single P line, with drainage to T;  
 - AM3VI on single A or B lines, and on A and B lines, with crossed drainage on A or B (see hydraulic symbols).  
 All versions can accept three types of springs with calibrated ranges as shown in the specifications.

Max. operating pressure	320 bar
Setting ranges:	spring 1 max. 50 bar spring 2 max. 150 bar spring 3 max. 320 bar
Max. flow	40 l/min
Hydraulic fluids	Mineral oils DIN 51524
Fluid viscosity	10 ÷ 500 mm <sup>2</sup> /s
Fluid temperature	-25°C ÷ 75°C
Ambient temperature	-25°C ÷ 60°C
Max. contamination level	class 10 in accordance with NAS 1638 with filter $\beta_{25} \geq 75$
Weight AM3VMA/B/P...	1,2 Kg
Weight AM3VMAB...	1,3 Kg
Weight AM3VIA/B...	2 Kg
Weight AM3VIAB...	2,2 Kg

The cartridge, which is the same for all versions, is the direct acting type CMP10.

**For the minimum permissible setting pressure depending on the spring, see minimum pressure setting curve.**

## ORDERING CODE

AM

Modular valve

3

CETOP 3/NG6

\*\*

VM = Maximum pressure  
VI = Maximum pressure crossline

\*\*

Adjustment on the lines  
AM3VM Version = A / B / P / AB  
AM3VI Version = A / B / AB

\*

Type of adjustment  
M = Plastic knob  
C = Grub screw

\*

Setting ranges at port A/B/P  
1 = max. 50 bar (**white spring**)  
2 = max. 150 bar (**yellow spring**)  
3 = max. 320 bar (**green spring**)

\*

Setting ranges at port B  
(Omit if the setting is same as that at port A)  
1 = max. 50 bar (**white spring**)  
2 = max. 150 bar (**yellow spring**)  
3 = max. 320 bar (**green spring**)

\*\*

00 = No variant  
V1 = Viton

3

Serial No.

## PRESSURE - FLOW RATE

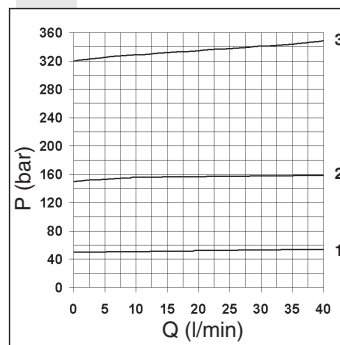

## MINIMUM SETTING PRESSURE

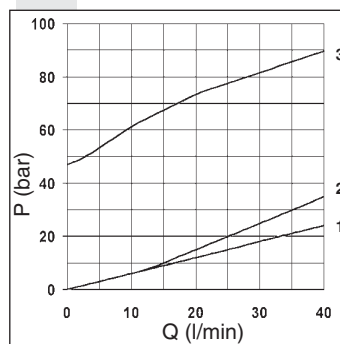

Curves n° 1 - 2 - 3 = setting ranges

## HYDRAULIC SYMBOLS

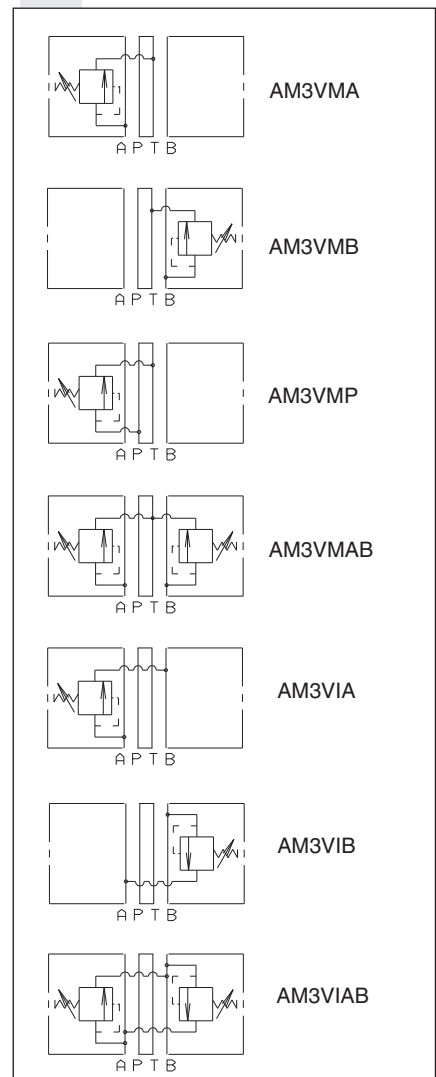

# AM3VM... / AM3VI... MODULAR MAX PRESSURE VALVES CETOP 3

## OVERALL DIMENSIONS

### AM.3.VM.AB...

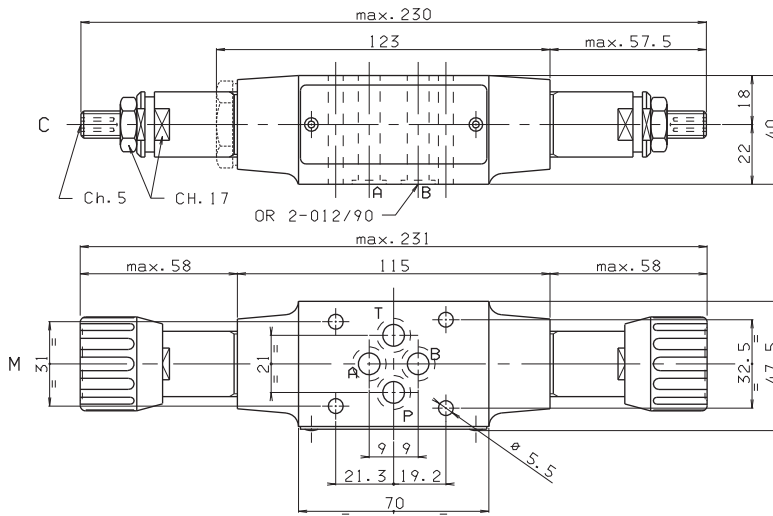

Type of adjustment

- M Plastic knob
- C Grub screw

Support plane specifications

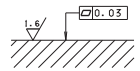

4

### AM.3.VM.P...

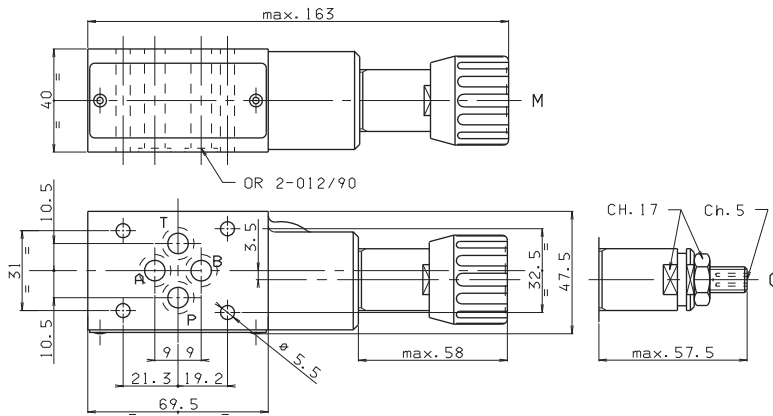

Type of adjustment

- M Plastic knob
- C Grub screw

Support plane specifications

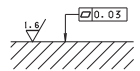

### AM.3.VI.AB...

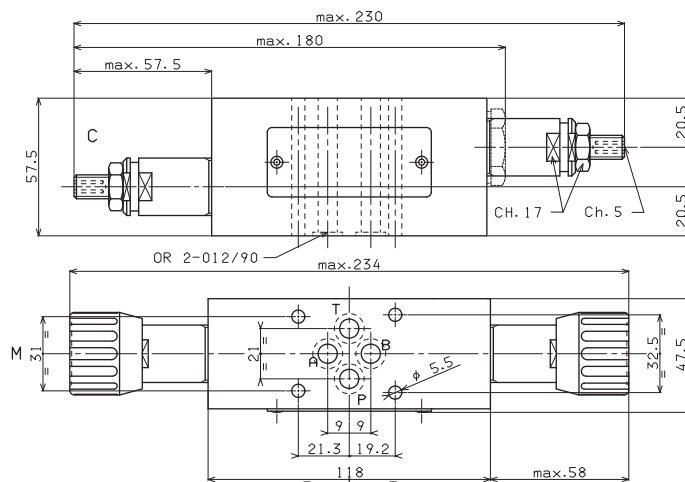

Type of adjustment

- M Plastic knob
- C Grub screw

Support plane specifications

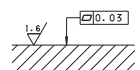



# AM3CP... MODULAR BACK PRESSURE VALVE CETOP 3



<b>AM3CP...</b>	
CMP.10...	CAP. VII • 30
SCREWS AND STUDS	CAP. IV • 21

AM3CP type back pressure valves are damped in-line direct acting pressure relief valves fitted with bypass non-return valves.

Adjustment within the range 2 ÷ 320 bar is by means of a grub screw or a plastic knob, on ports A or B (single) or AB (double).

The cartridge is the direct acting type CMP10.

These valves are especially used on vertically working cylinders with dragging loads.

Max. operating pressure	350 bar	
Setting ranges:	spring 1	max. 50 bar
	spring 2	max. 150 bar
	spring 3	max. 320 bar
Max. flow	40 l/min	
Hydraulic fluids	Mineral oils DIN 51524	
Fluid viscosity	10 ÷ 500 mm <sup>2</sup> /s	
Fluid temperature	-25°C ÷ 75°C	
Ambient temperature	-25°C ÷ 60°C	
Max. contamination level	class 10 in accordance with NAS 1638 with filter β <sub>25</sub> ≥ 75	
Weight AM3CPA/B...	2 Kg	
Weight AM3CPAB...	2,7 Kg	

For the minimum permissible setting pressure depending on the spring, see minimum pressure setting curve.

## ORDERING CODE

<b>AM</b>	Modular valve
<b>3</b>	CETOP 3/NG6
<b>CP</b>	Back pressure valve
<b>**</b>	Control on lines <b>A / B / AB</b>
<b>*</b>	Type of adjustment <b>M</b> = Plastic knob <b>C</b> = Grub screw
<b>*</b>	Setting ranges <b>1</b> = max. 50 bar ( <b>white spring</b> ) <b>2</b> = max. 150 bar ( <b>yellow spring</b> ) <b>3</b> = max. 320 bar ( <b>green spring</b> )
<b>**</b>	<b>00</b> = No variant <b>V1</b> = Viton
<b>3</b>	Serial No.

## HYDRAULIC SYMBOLS

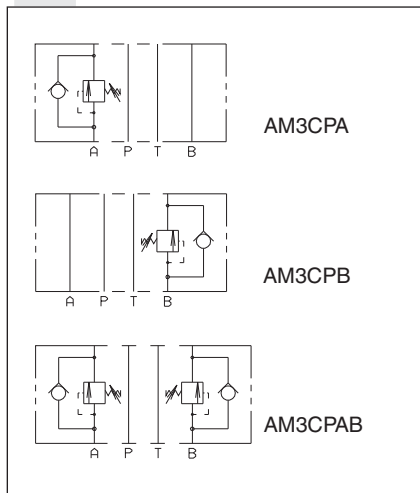

## PRESSURE - FLOW RATE

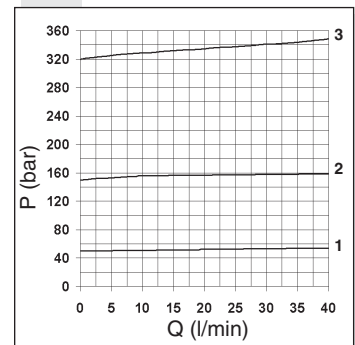

## MINIMUM SETTING PRESSURE

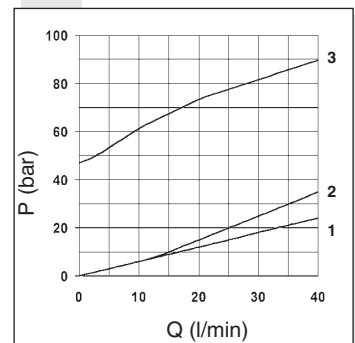

## OVERALL DIMENSIONS

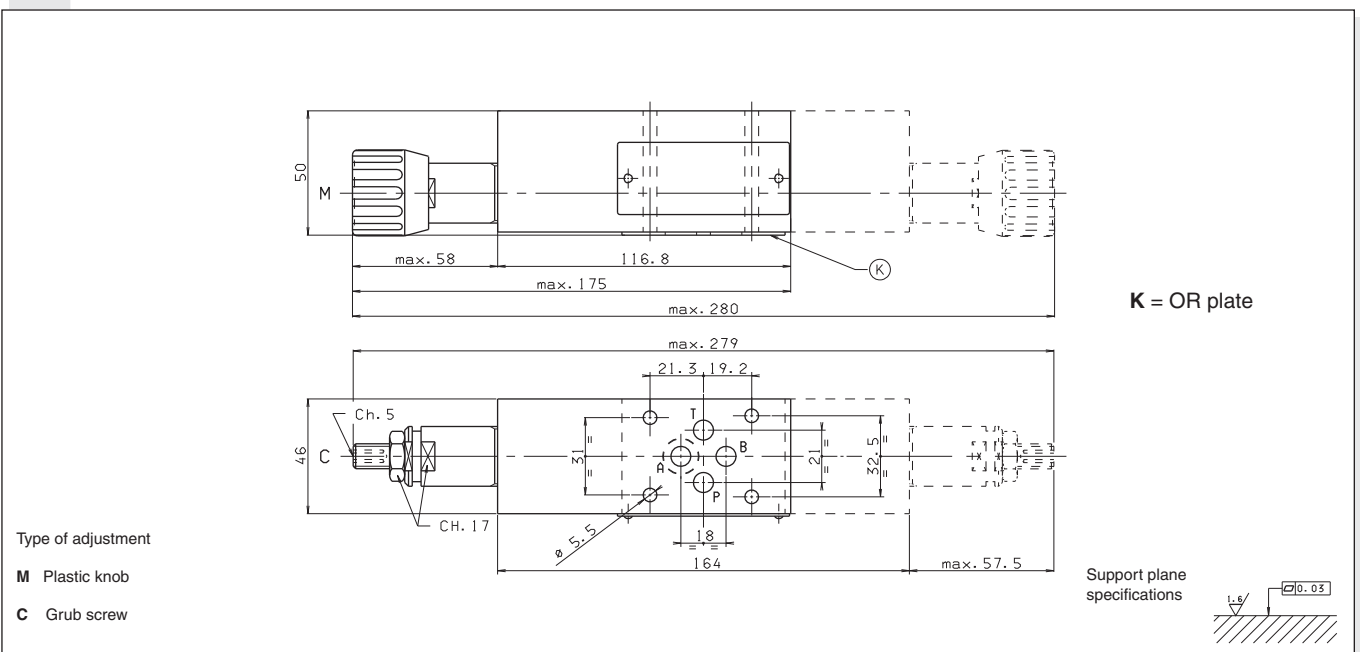

# AM3RD... / AM3SD... MODULAR PRESSURE REDUCING / PRESSURE SEQUENCING VALVES CETOP 3



**AM3RD / AM3SD...**

SCREWS AND STUDS

CAP. IV • 21

AM3RD and AM3SD valves are direct acting spool type pressure reducing and sequencing units, respectively, with one end pre-loaded by means of a spring at the other end exposed to the hydraulic pressure.

The drainage is drained within the valve to port T. Pressure is adjustable by means of a screw and locknut, or of a handwheel. Three types of springs allow adjustment within the range 2÷250 bar. The pressure reducing valves are available in two versions: with positive overlap (suitable with low flow rate) and with negative overlap to obtain a greater pressure reinstatement speed.

Max. operating pressure: port P	350 bar
Max. pressure adjustable	250 bar
Setting ranges:	
spring 1	2 ÷ 30 bar
spring 2	10 ÷ 120 bar
spring 3	60 ÷ 250 bar
Max. flow	40 l/min
Internal drainage RD:	
Positive overlap version	0,5 l/min
Negative overlap version	2 l/min
Hydraulic fluids	Mineral oils DIN 51524
Fluid viscosity	10 ÷ 500 mm <sup>2</sup> /s
Fluid temperature	-25°C ÷ 75°C
Ambient temperature	-25°C ÷ 60°C
Max. contamination level	class 10 in accordance with NAS 1638 with filter β <sub>25</sub> ≥ 75
Weight	1,3 Kg

## ORDERING CODE

**AM**

Modular valve

**3**

CETOP 3/NG6

**\*\***

**RD** = Direct pressure reducing valve  
**SD** = Direct pressure sequencing valve

**\***

Control on lines

AM3RD version = **A / P**

AM3SD version = **P**

**\***

**1** = Positive overlap

**2** = Negative overlap

Omit for version AM3SD

**\***

Type of adjustment

**C** = Grub screw

**V** = Handwheel

**\***

Setting ranges

**1** = max. 2 ÷ 30 bar (**white spring**)

**2** = max. 10 ÷ 120 bar (**yellow spring**)

**3** = max. 60 ÷ 250 bar (**green spring**)

**\*\***

**00** = No variant

**V1** = Viton

**4**

Serial No.

**PRESSURE - FLOW RATE AM3RD**

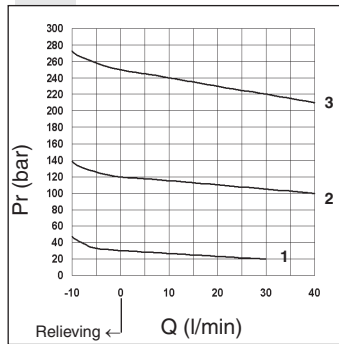

**PRESSURE - FLOW RATE AM3SD**

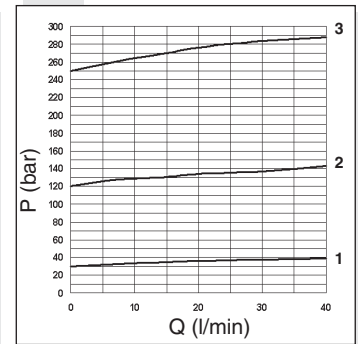

The fluid used is a mineral based oil with a viscosity of 46 mm<sup>2</sup>/sec at 40 degrees C. The tests have been carried out at with a fluid temperature of 40 degrees C.

## OVERALL DIMENSIONS

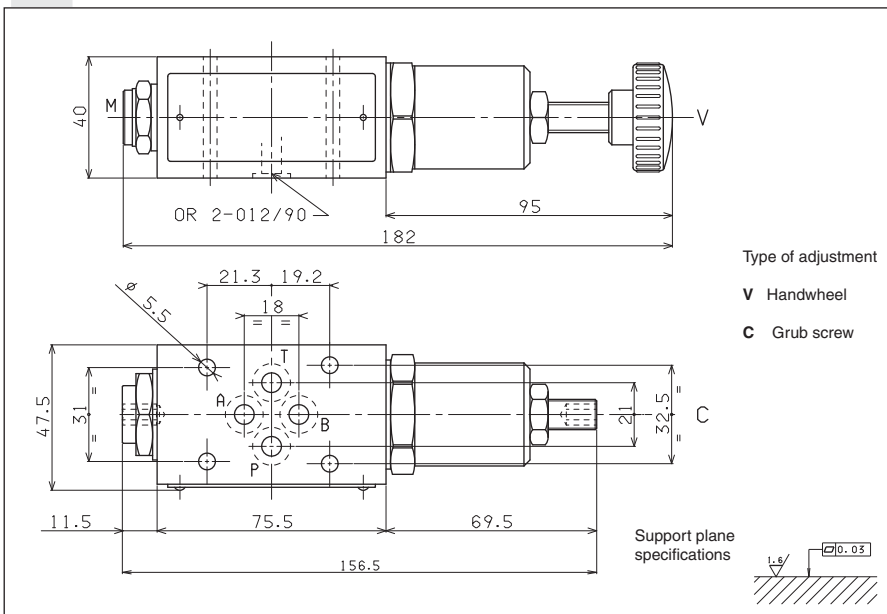

## HYDRAULIC SYMBOLS

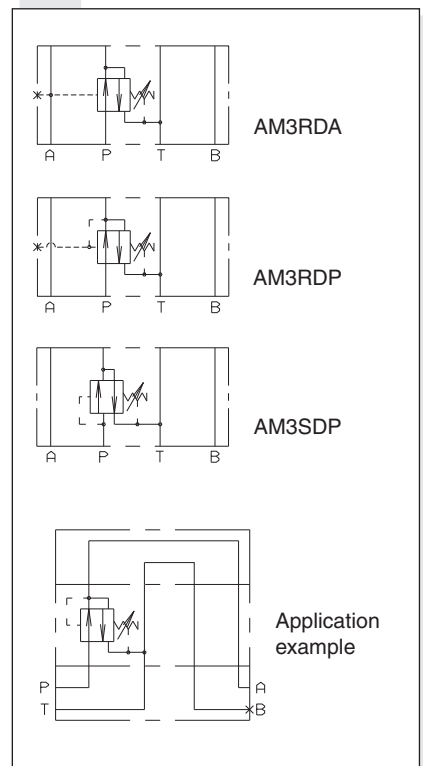

# AM3VR... MODULAR REDUCING VALVES WITH RELIEVING - PILOT OPERATED CETOP 3

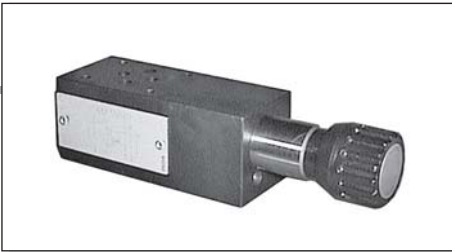

**AM3VR...**  
CVR.20... CATALOGO CARTUCCE  
SCREWS AND STUDS CAP. IV • 21

These pressure reducing valves ensure a minimum pressure variation on the P or A port with changing flow rate up to 90 l/min.

Three spring types allow adjustment within the range 7 ÷ 250 bar. Manual adjustment is available by a grub screw or plastic knob.

The RELIEVING SYSTEM inside the valve AM3VR allows the passage from the setting pressure line to T line of the flow through the valve to avoid the increasing of pressure in the reduced-pressure line by diverting exceeding flow to reservoir. A bypass module with check valve for free flow from A to AR port (see hydraulic symbol) is available..

Max. operating pressure 350 bar  
Setting ranges: spring 1 max. 60 bar  
spring 2 max. 120 bar  
spring 3 max. 250 bar

**Maximum allowed  $\Delta p$  pressure between the inlet an outlet pressure 150 bar**  
Max. flow 40 l/min  
Draining on port T 0,5 ÷ 0,7 l/min  
Hydraulic fluids Mineral oils DIN 51524  
Fluid viscosity 10 ÷ 500 mm<sup>2</sup>/s  
Fluid temperature -25°C ÷ 75°C  
Ambient temperature -25°C ÷ 60°C  
Max. contamination level class 10 in accordance with NAS 1638 with filter  $\beta_{25} \geq 75$   
Weight 1,36 Kg  
Weight bypass version 2 Kg

## ORDERING CODE

- AM** Modular valve
- 3** CETOP 3/NG6
- VR** Pilot operated pressure reducing valve with relieving
- \*** Control on lines  
P = Drain on T  
A = Drain on T  
D = Drain on B reduct pressure on A
- \*** Drain connection  
E = External (only for control on the P line)  
I = Internal (Standard)
- B** Version with bypass on line A only  
**Omit if not required**
- \*** Type of adjustment  
M = Plastic knob  
C = Grub screw
- \*** Setting ranges  
1 = max. 60 bar (**white spring**)  
2 = max. 120 bar (**yellow spring**)  
3 = max. 250 bar (**green spring**)
- \*\*** 00 = No variant  
V1 = Viton
- 1** Serial No

To changes valves AM3VRP... from internal to external drainage it is necessary:  
- screw out the plug on the "Y" port  
- screw out the plug T.C.E.I. M8x1 from the body  
- screw in a screw S.T.E.I. M6  
- rescrew the T.C.E.I. M8x1 plug on the body

**NOTE:** the external draining can be used as a piloting line (please, contact our technical department for other informations)

## HYDRAULIC SYMBOLS

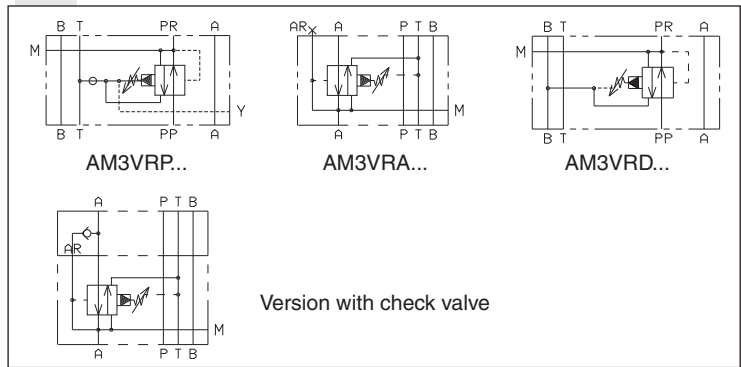

## PRESSURE-FLOW RATE

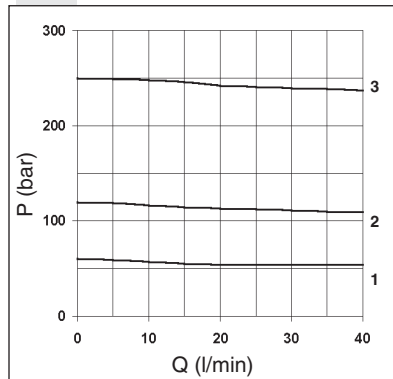

## PRESSURE-FLOW OF RELIEVING

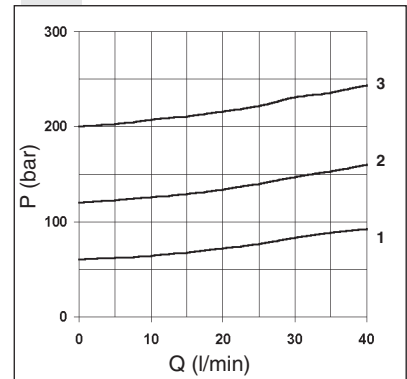

## $\Delta P$ AM3+VR... + BYPASS

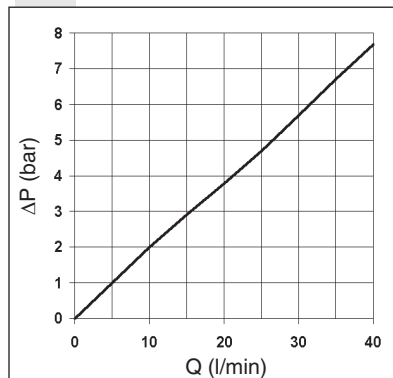

## MINIMUM SETTING PRESSURE

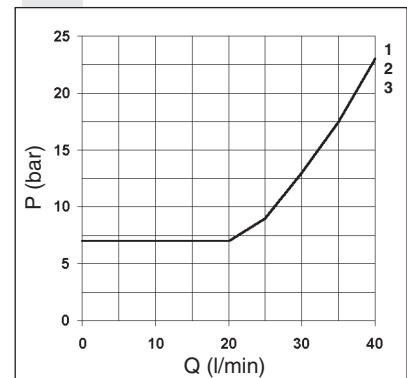

Curves n° 1 - 2 - 3 = setting ranges

The fluid used is a mineral oil with a viscosity of 46 mm<sup>2</sup>/s at 40°C. The tests have been carried out a fluid temperature of 50°C.

## OVERALL DIMENSIONS

### AM.3.VR.P... / AM.3.VR.D...

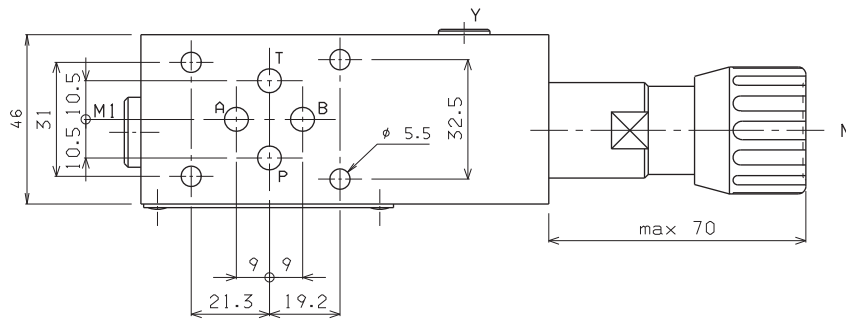
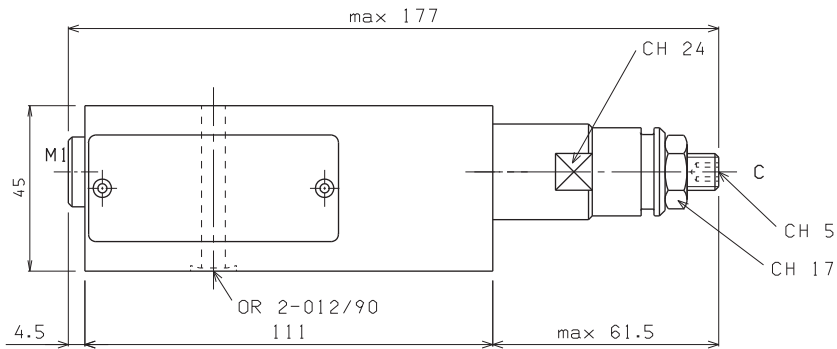

**(B)** Bypass (optional)  
 Ordering code:  
 V89.45.000  
 (if ordered separately)

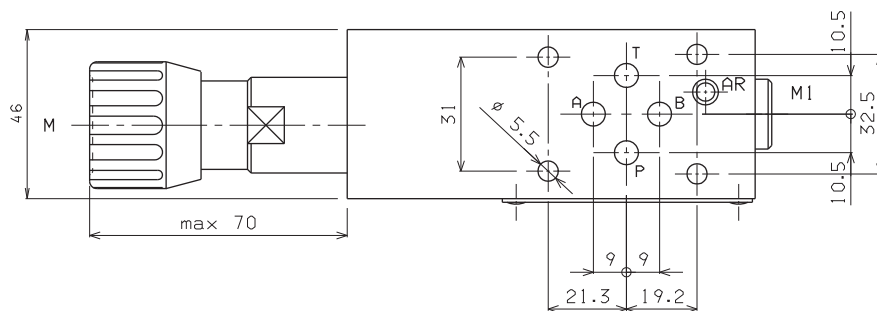
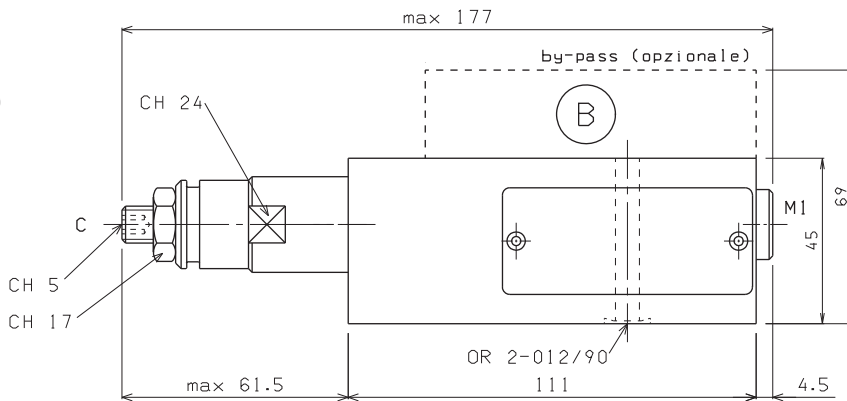

Type of adjustment

**M** Plastic knob

**C** Grub screw

Support plane  
 specifications

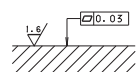

4

# AM3VS... MODULAR SEQUENCING VALVES CETOP 3

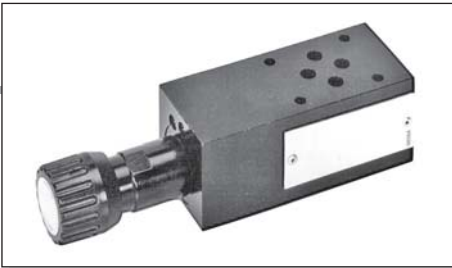

AM3VS...

CVS.20... CARTRIDGE CATALOGUE  
SCREWS AND STUDS CAP. IV • 21

The sequence valve are used to assure that a secondary circuit is pressurized when the setting pressure is reached.

These valves grant a minimum variation of the setting pressure with a changing flow up to 40 l/min (see diagram).

Three spring types allow adjustment within the range 7 ÷ 250 bar. Manual adjustment is available by a grub screw or plastic knob.

The cartridge used is the "CVS" type.

Max. operating pressure	350 bar
Setting ranges:	Spring 1 max. 60 bar
	Spring 2 max. 120 bar
	Spring 3 max. 250 bar
Max. flow	40 l/min
Draining on port T	0,5 ÷ 0,7 l/min
Hydraulic fluids	Mineral oils DIN 51524
Fluid viscosity	10 ÷ 500 mm <sup>2</sup> /s
Fluid temperature	-25°C ÷ 75°C
Ambient temperature	-25°C ÷ 60°C
Max. contamination level	class 10 in accordance with NAS 1638 with filter β <sub>25</sub> ≥ 75
Weight	1,36 Kg

## ORDERING CODE

<b>AM</b>	Modular valve
<b>3</b>	CETOP 3/NG6
<b>VS</b>	Sequencing valve
<b>*</b>	Drain connection <b>E</b> = External <b>I</b> = Internal (Standard)
<b>*</b>	Type of adjustment <b>M</b> = Plastic knob <b>C</b> = Grub screw
<b>*</b>	Setting ranges <b>1</b> = max. 60 bar ( <b>white spring</b> ) <b>2</b> = max. 120 bar ( <b>yellow spring</b> ) <b>3</b> = max. 250 bar ( <b>green spring</b> )
<b>**</b>	<b>00</b> = No variant <b>V1</b> = Viton
<b>1</b>	Serial No

The fluid used is a mineral oil with a viscosity of 46 mm<sup>2</sup>/s at 40°C. The tests have been carried out at a fluid temperature of 50°C.

Curves n° 1 - 2 - 3 = setting ranges

## HYDRAULIC SYMBOL

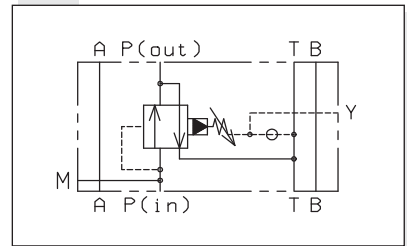

## PRESSURE-FLOW RATE

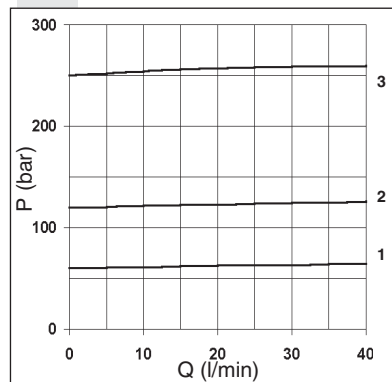

## MINIMUM SETTING PRESSURE

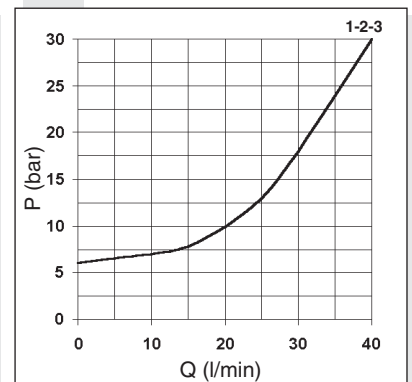

## OVERALL DIMENSIONS

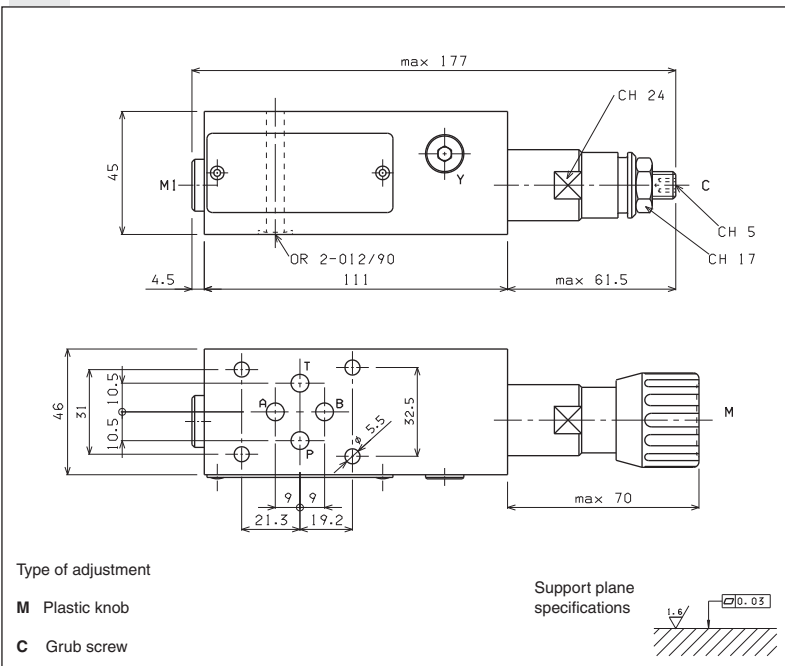

To changes valves AM.3.VS... from internal to external drainage it is necessary:

- screw out the plug on the Y port
- screw out the plug T.C.E.I. M8x1 from the body
- screw in a screw S.T.E.I. M6
- rescrew the T.C.E.I. M8x1 plug on the body

**NOTE:** the external draining can be used as a piloting line (please, contact our technical department for other informations)



# AM3QF... MODULAR FLOW REGULATOR CETOP 3



**AM3QF...**

SCREWS AND STUDS

CAP. IV • 21

AM.3.QF type one way non-compensated throttle valve are fitted with an O-Ring mounting plate which allows its assembly for either input or output regulation. Adjustment is obtained by means of a grub screw or a plastic knob. They are available in the four regulating configurations shown in the hydraulic diagrams.

The standard valve configuration allows "meter in" regulation, while it is possible to obtain "meter out" regulation by turning the valve by 180° along its longitudinal axis.

Max. operating pressure	350 bar
Max. pressure adjustable	250 bar
Flow rate regulation	on 8 screw turns
Max. flow	40 l/min
Hydraulic fluids	Mineral oils DIN 51524
Fluid viscosity	10 ÷ 500 mm <sup>2</sup> /s
Fluid temperature	-25°C ÷ 75°C
Ambient temperature	-25°C ÷ 60°C
Max. contamination level	class 10 in accordance with NAS 1638 with filter $\beta_{25} \geq 75$
Weight	1,5 Kg

## ORDERING CODE

<b>AM</b>	Modular valve
<b>3</b>	CETOP 3/NG6
<b>QF</b>	Non compensated throttle valve
<b>**</b>	Control on lines <b>A / B / P / AB</b>
<b>*</b>	Type of adjustment <b>M</b> = Plastic knob <b>C</b> = Grub screw
<b>**</b>	<b>00</b> = No variant <b>V1</b> = Viton
<b>4</b>	Serial No.

## FLOW REGULATION

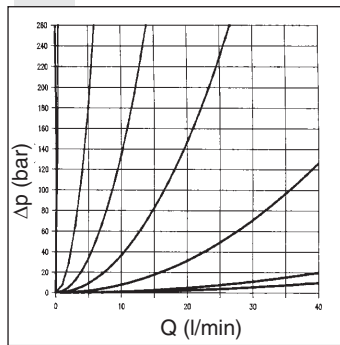

## FREE FLOW

TOWARDS CHECK VALVE

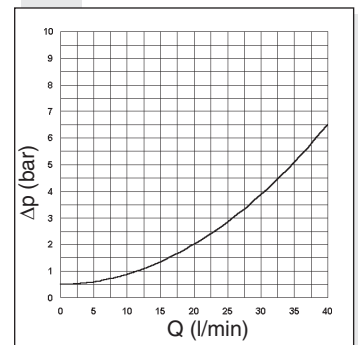

## HYDRAULIC SYMBOLS

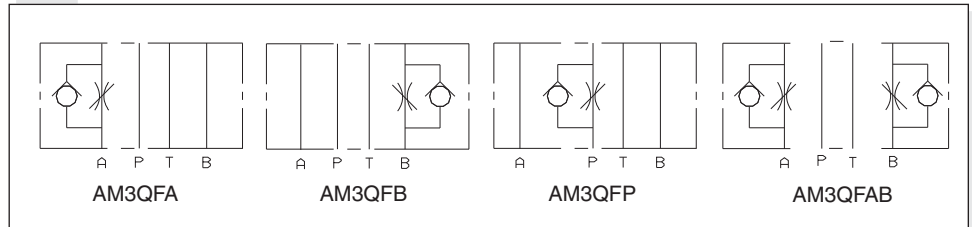

## OVERALL DIMENSIONS

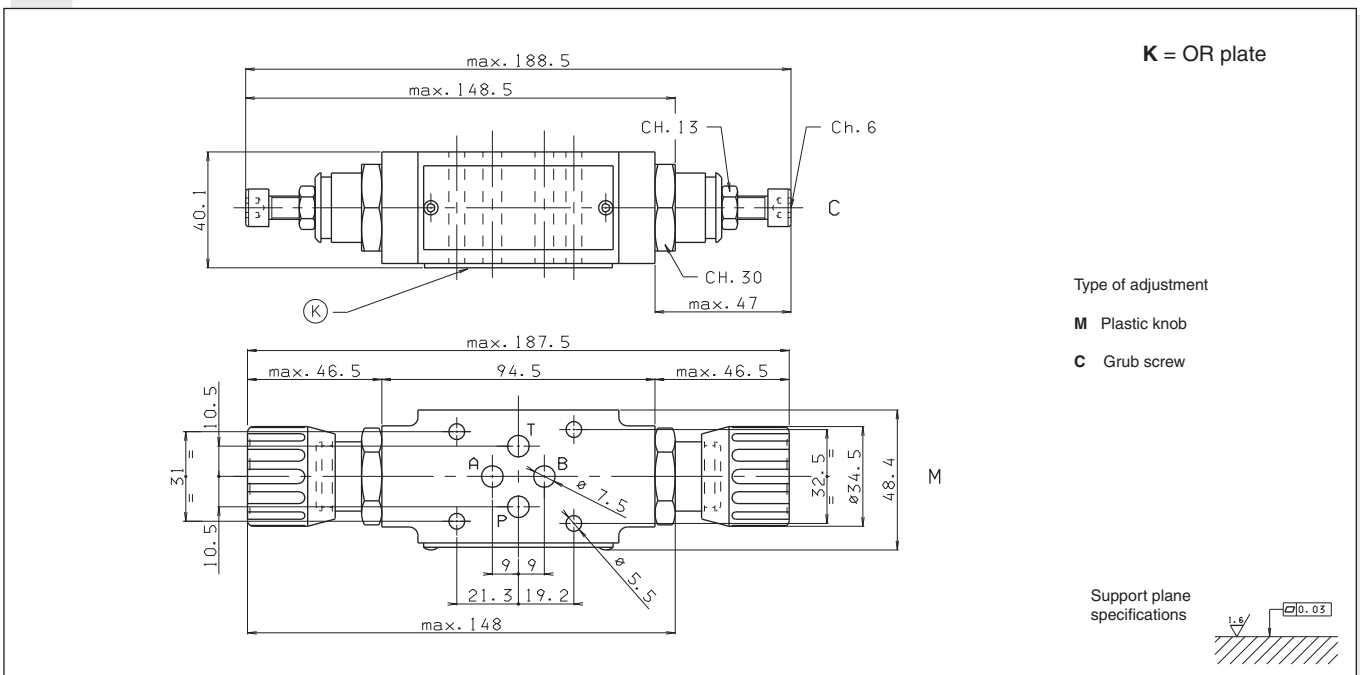

# AM66... MODULAR COMPENSATED FLOW CONTROL ASSEMBLY CETOP 3



This is an intermediate block for modular mounting of one or two flow rate regulators type QC3...

The flow regulator type QC3\* must be ordered separately.

Max. operating pressure	320 bar
Hydraulic fluids	Mineral oils DIN 51524
Fluid viscosity	10 ÷ 500 mm <sup>2</sup> /s
Fluid temperature	-25°C ÷ 75°C
Ambient temperature	-25°C ÷ 60°C
Max. contamination level	class 10 in accordance with NAS 1638 with filter $\beta_{25} \geq 75$
Weight	1,3 Kg

## AM066...

QC32...	CAP. III • 2
QC33...	CAP. III • 3
SCREWS AND STUDS	CAP. IV • 21

4

## ORDERING CODE

AM

Modular valve

66

Size

\*\*

Control on lines

**A / B / P / PT\* / AB**

For T / A1 / B1 / A1B1 versions see table "Hydraulic symbols"

\*\*

**00** = No variant

**V3** = regulators for three-way QC33 (only with adjustment of P)

**V1** = Viton

3

Serial No.

## HYDRAULIC SYMBOLS

### For regulators two-way QC32

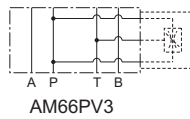
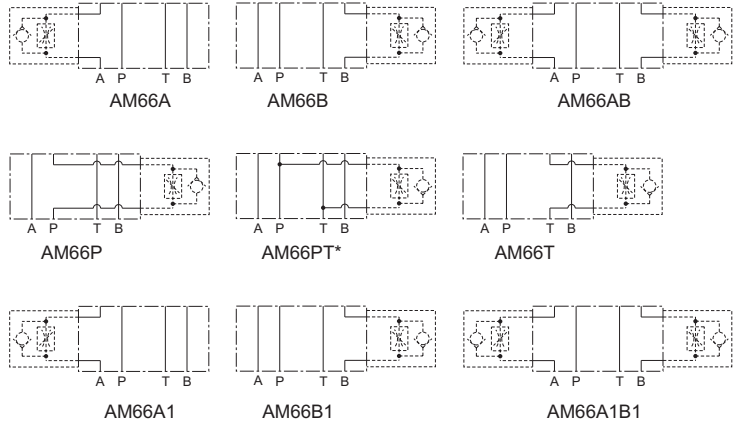

### For regulators for three-way QC33

**PT\*** = From line towards exhaust (P → T drain)

• In order to obtain versions with regulation on **T**, the AM66P regulator carrying block should be turned by 180°.

• In order to obtain versions **A1**, **B1** and **A1B1** the AM66A, AM66B or AM66AB regulators carrying block should be turned by 180°.

## OVERALL DIMENSIONS

K = OR plate

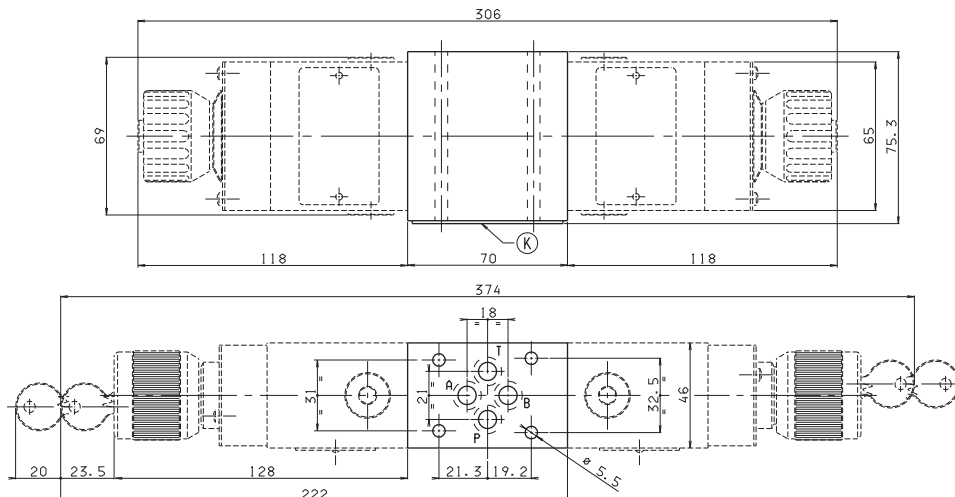



# A66... MODULAR FLOW CONTROL VALVES

## FAST / SLOW ASSEMBLY CETOP 3



A66...	
STANDARD CONNECTORS	CAP. I • 20
DC COILS	CAP. I • 72
QC32...	CAP. III • 2
SCREWS AND STUDS	CAP. IV • 21

This is modular assembly ON/OFF solenoid valve which, by fitting suitable 2 way regulator, allows two speed operation in the same system via an electrical changeover command.

**The flow rate regulator type QC32... must be ordered separately.**  
**The operational limit curves have been obtained with the regulator fully closed, and those same limits improve gradually with the opening of the regulator.**

Max. operating pressure	320 bar
Hydraulic fluids	Mineral oils DIN 51524
Fluid viscosity	10 ÷ 500 mm <sup>2</sup> /s
Fluid temperature	-25°C ÷ 75°C
Ambient temperature	-25°C ÷ 60°C
Max. contamination level	class 10 in accordance with NAS 1638 with filter $\beta_{25} \geq 75$
Weight	2,4 Kg

The test have been carried out at operating temperature, with a voltage 10% lower than rated voltage and with a fluid temperature of 50 degrees C. The fluid used was a mineral based oil with a viscosity of 46 mm<sup>2</sup>/s at 40 degrees C.

### ORDERING CODE

<b>A</b>	Speed control valve
<b>66</b>	Size
<b>E</b>	Electrical operator
<b>***</b>	<b>120</b> = Normally open <b>121</b> = Normally closed See table hydraulic symbols
<b>*</b>	Control on lines <b>A/B/P/T</b> (see symbols) The interface holder "H" must be turned by 180° in order to obtain the <b>A1</b> and <b>B1</b> versions.
<b>*</b>	Voltage: see tab.1
<b>**</b>	Variants: see tab.2
<b>4</b>	Serial No.

### LIMITS OF USE

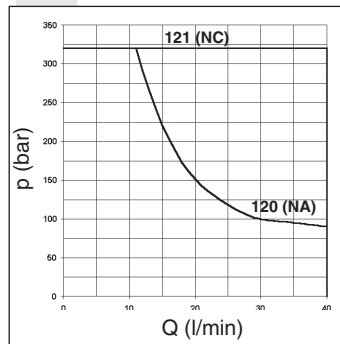

### HYDRAULIC SYMBOLS

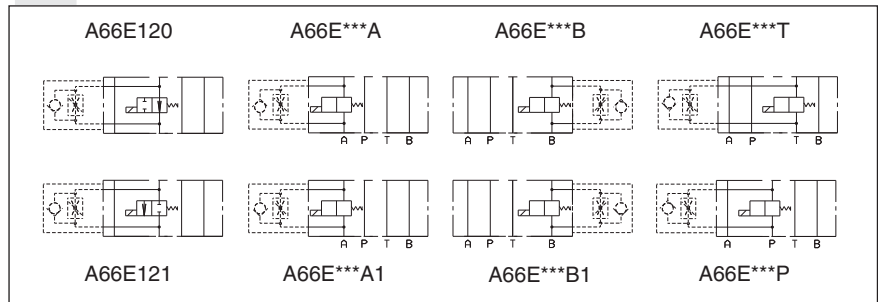

### TAB.1 VOLTAGE

#### D15 COILS (IN DC - 30W) \*\*

L	12V	115Vac/50Hz 120Vac/60Hz with rectifier
M	24V	
V	28V*	230Vac/50Hz 240Vac/60Hz with rectifier
N	48V*	
Z	102V*	230Vac/50Hz 240Vac/60Hz with rectifier
P	110V*	
X	205V*	230Vac/50Hz 240Vac/60Hz with rectifier
W	without coils	

Voltage codes are not stamped on the plate, their are readable on the coils.

\* Special voltage

\*\* Technical data see Cap. XII • 4

### TAB.2 - VARIANTS

No variant (without connectors)	S1(*)
Viton	SV(*)
Other variants available on request	

(\*) Coils with Hirschmann connection supplied without connectors. The connectors can be ordered separately, Cap. I • 20.

### OVERALL DIMENSIONS

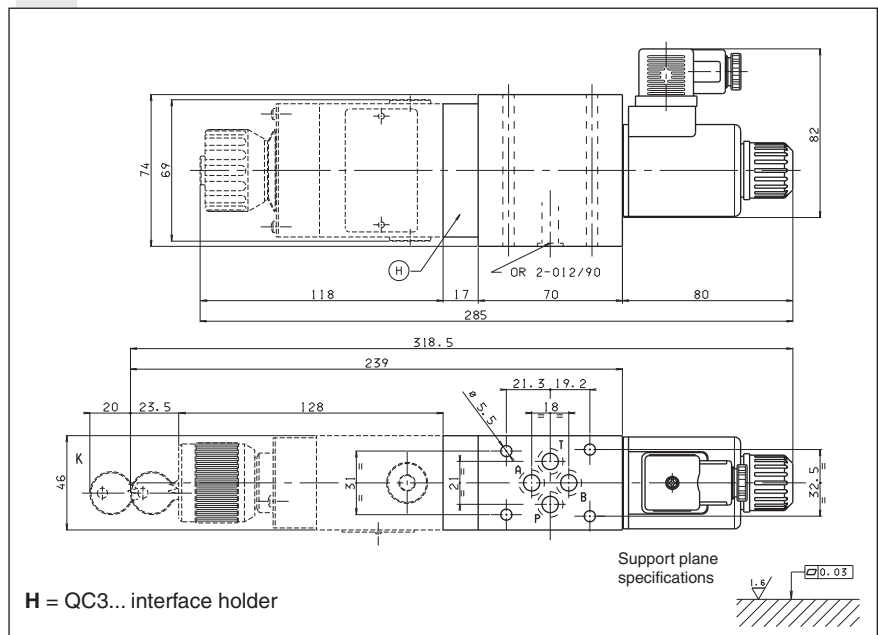

## AM3RGT... MODULAR VALVES FOR REGENERATIVE CIRCUIT CETOP 3



AM3RGT...

SCREWS AND STUDS

CAP. IV • 21

This modular valve produces a regenerative system to increase the actuator (differential cylinder) exit speed as shown in the diagram.

In particular, if a cylinder is used with a 2:1 ratio for the operating surfaces, the exit and re-entry speeds are the same.

Max. operating pressure	350 bar
Max. flow at port A/B/P/T	20 l/min
Hydraulic fluids	Mineral oils DIN 51524
Fluid viscosity	10 ÷ 500 mm <sup>2</sup> /s
Fluid temperature	-25°C ÷ 75°C
Ambient temperature	-25°C ÷ 60°C
Max. contamination level	class 10 in accordance with NAS 1638 with filter $\beta_{25} \geq 75$
Weight	1,7 Kg

4

### ORDERING CODE

<b>AM</b>	Modular valve
<b>3</b>	CETOP 3/NG6
<b>RGT</b>	For regenerative circuit
<b>A</b>	Size of check valves 3/8" BSP
<b>1</b>	Opening pressure 1 bar
<b>**</b>	<b>00</b> = No variant <b>V1</b> = Viton
<b>1</b>	Serial No.

### PRESSURE DROPS A → P

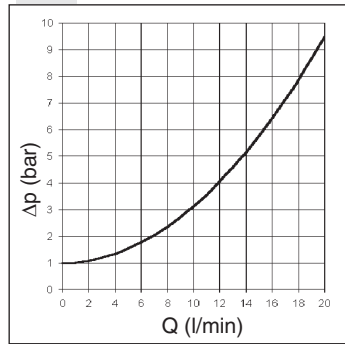

### HYDRAULIC SYMBOL

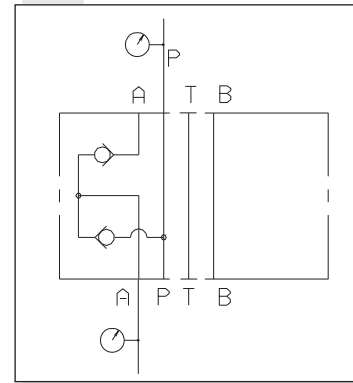

### OVERALL DIMENSIONS

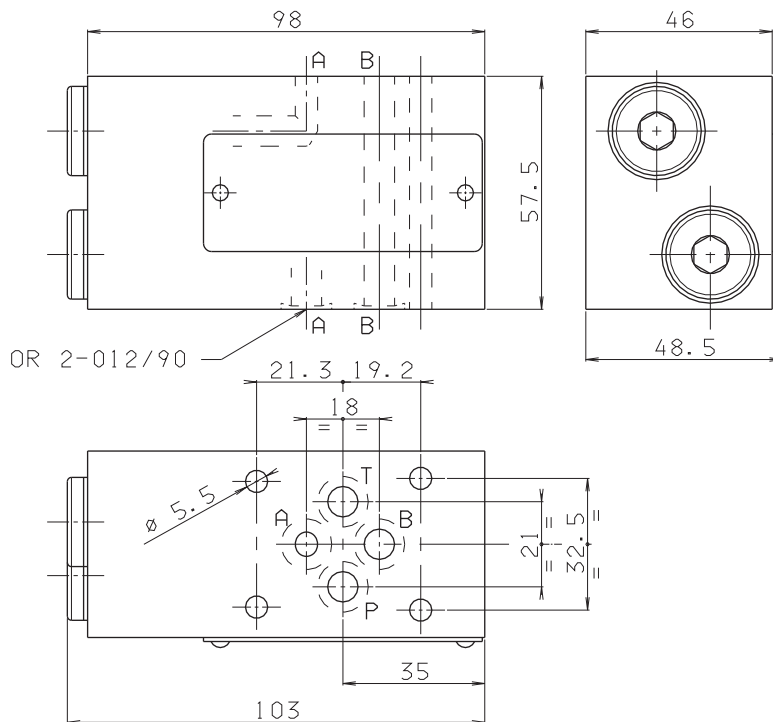

Support plane specifications

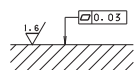

# TABLE OF SCREWS AND STUDS FOR MOUNTING MODULES CETOP 3

## OVERALL DIMENSIONS

Tighten M27.05.0001 to a torque of **5 Nm / 0.5 Kgm max.**

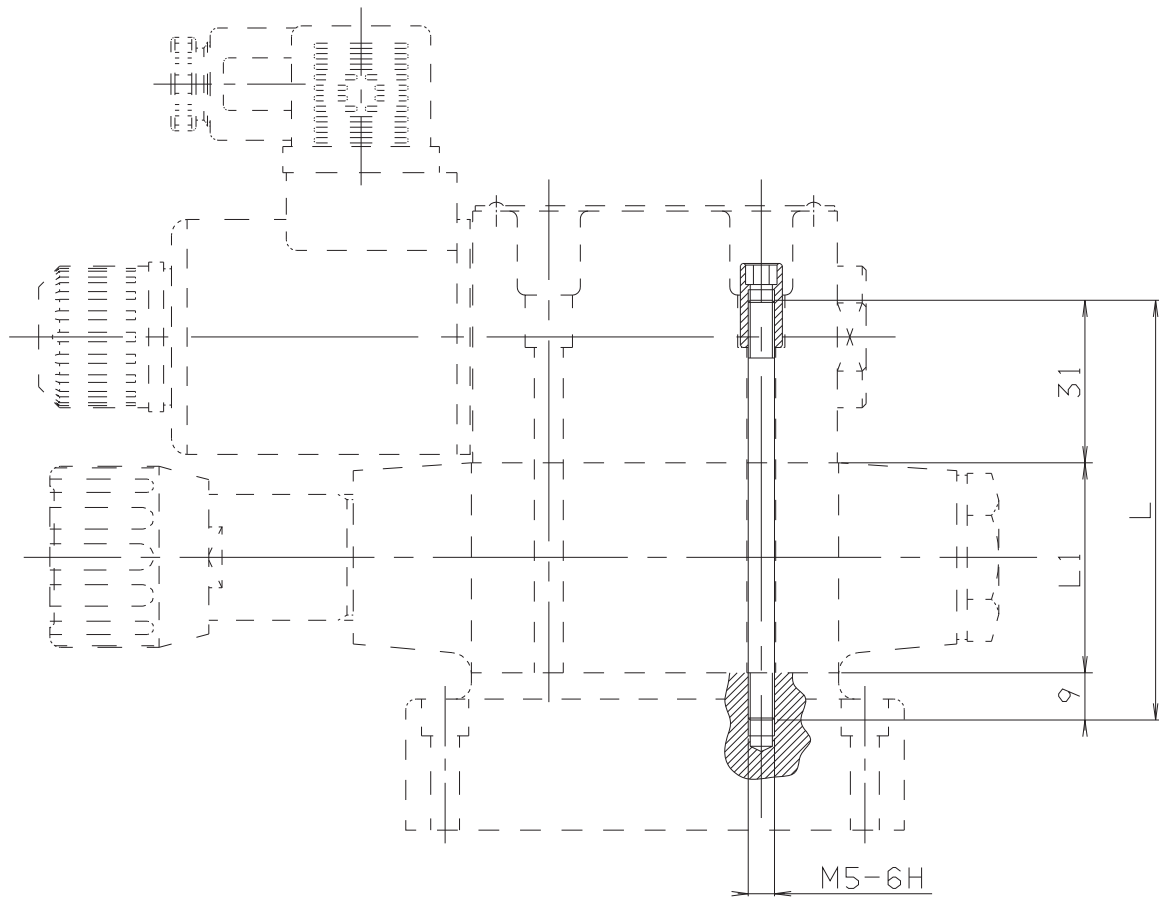

4

SCREWS T.C.E.I CODE	L mm	L1* mm	COMPOSITION	Q.TY	SPECIAL NUTS CODE
Q26074068	30	—	AD3...	4	—
Q26074075	70	40	AD3... + 1 AM3... (ISO)	4	
Q26074076	75	45	AD3... + AM3VR	4	
M80100015	97	57,5	AD3... + AM3VI...	4	V89240000 (No. 20 nuts kit)
M80100007	115	74	AD3... + A66 o AM66...	4	
M80100003	120	80	AD3... + 2 AM3... (ISO)	4	
M80100013	125	85	AD3... + AM3VR... + AM3... (ISO)	4	
M80100011	155	114	AD3... + A66... + AM3... (ISO)	4	
M80100005	160	119	AD3... + A66... + AM3VR	4	
M80100005	160	120	AD3... + 3 AM3... (ISO)	4	
M80100020	165	125	AD3 + AM3VR + 2 AM3... (ISO)	4	
M80100017	170	130	AD3 + AM3CP + 2 AM3... (ISO)	4	
M80100023	195	154	A66... + 2 AM3... (ISO)	4	

\* Indicative overall dimensions valves composition

# AM5UD... MODULAR DIRECT CHECK VALVES CETOP 5



AM5UD...

SCREWS AND STUDS

CAP. IV • 36

AM5UD type modular check valves allow free flow in one direction, while a conical seated poppet prevents flow in the opposite direction.

They are available on single A, B, P and T lines, and on double A and B, P and T lines (see hydraulic symbols).

1 bar springs are standard, while 5 bar rated springs are available on request.

Max. operating pressure	350 bar
Minimum opening pressure spring 1	1 bar
Minimum opening pressure spring 5	5 bar
Max. flow	80 l/min
Hydraulic fluids	Mineral oils DIN 51524
Fluid viscosity	10 ÷ 500 mm <sup>2</sup> /s
Fluid temperature	-25°C ÷ 75°C
Ambient temperature	-25°C ÷ 60°C
Max. contamination level	class 10 in accordance with NAS 1638 with filter $\beta_{25} \geq 75$
Weight	2,1 Kg

4

### ORDERING CODE

<b>AM</b>	Modular valve
<b>5</b>	CETOP 5/NG10
<b>UD</b>	Direct check valve
<b>**</b>	Control on lines <b>A / B / P / T / AB / PT</b>
<b>*</b>	Minimum opening pressure <b>1 = 1 bar</b> <b>5 = 5 bar</b>
<b>**</b>	<b>00 = No variant</b> <b>V1 = Viton</b>
<b>2</b>	Serial No.

### PRESSURE DROPS

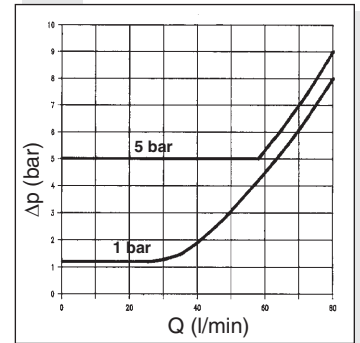

### OVERALL DIMENSIONS

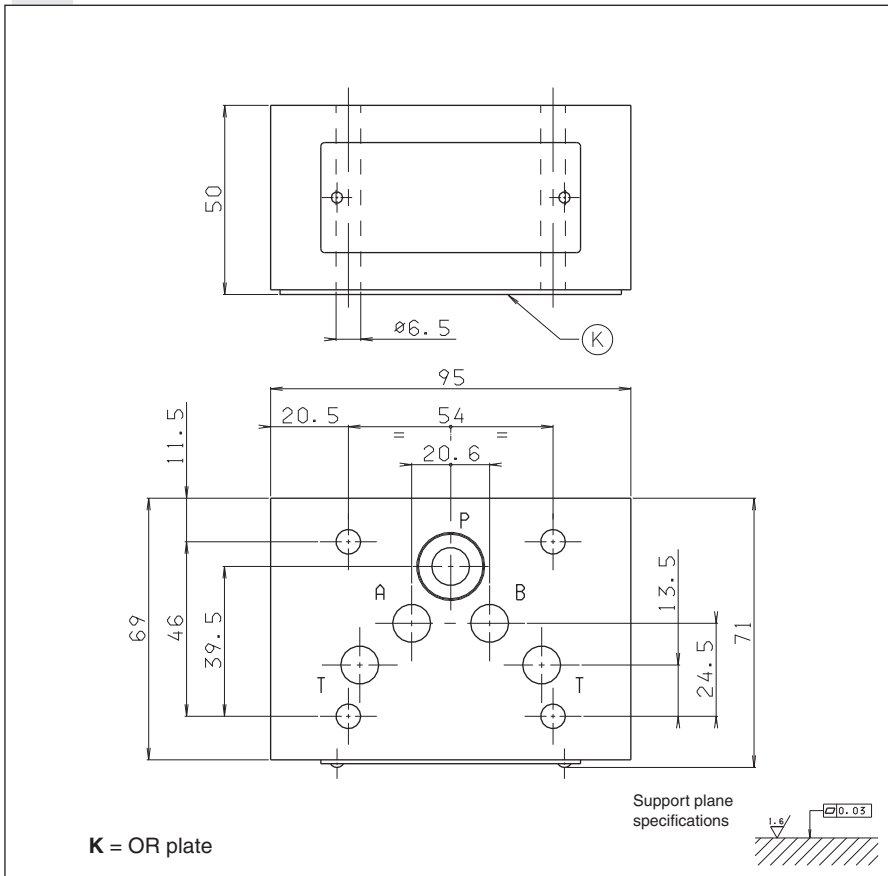

### HYDRAULIC SYMBOLS

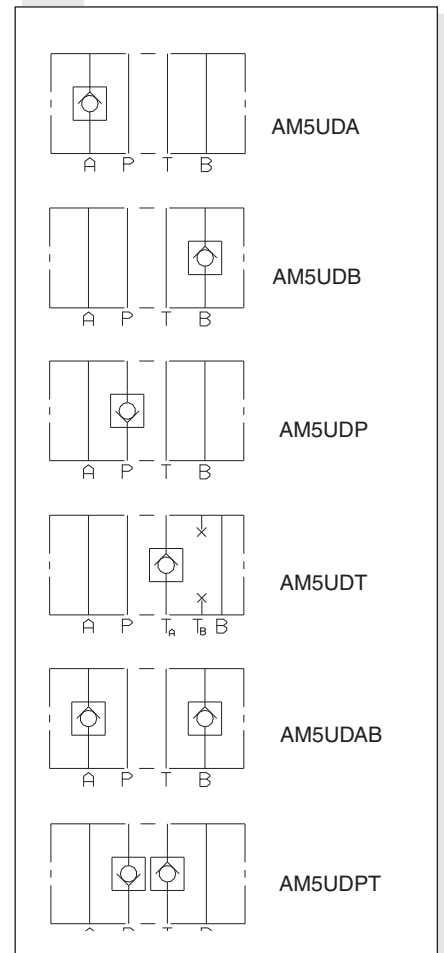



AM5UP...

SCREWS AND STUDS

CAP. IV • 36

## AM5UP... MODULAR

### PILOT OPERATED CHECK VALVES CETOP 5

AM5UP type modular check valves allow free flow in one direction by lifting a conical steel seated poppet, while in the opposite direction the fluid can return by means of a small piston piloted by the other line pressure (piloted side).

The cast valve body allows limited pressure drops during the fluid flow through the various P/A/B/T lines.

They are available on single A or B lines, and on double A and B lines (see hydraulic symbols).

Max. operating pressure	280 bar
Minimum opening pressure spring 1	1 bar
Minimum opening pressure spring 5	5 bar
Piloting ratio	1 : 14,3
Max. flow	80 l/min
Hydraulic fluids	Mineral oils DIN 51524
Fluid viscosity	10 ÷ 500 mm <sup>2</sup> /s
Fluid temperature	-25°C ÷ 75°C
Ambient temperature	-25°C ÷ 60°C
Max. contamination level	class 10 in accordance with NAS 1638 with filter $\beta_{25} \geq 75$
Weight	2,7 Kg

#### ORDERING CODE

AM

Modular valve

5

CETOP 5/NG10

UP

Piloted check valve

\*\*

Control on lines  
A / B / AB

\*

Minimum opening pressure  
1 = 1 bar  
5 = 5 bar

\*\*

00 = No variant  
V1 = Viton

5

Serial No.

#### PRESSURE DROPS

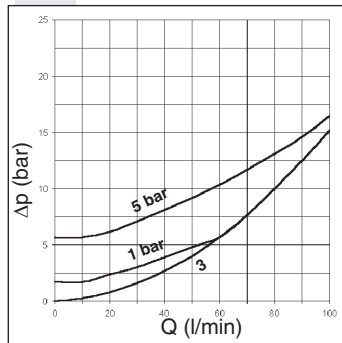

Curve n. 3 = Piloted side flow

The fluid used is a mineral oil with a viscosity of 46 mm<sup>2</sup>/s at 40°C. The tests have been carried out at a fluid temperature of 50°C.

#### HYDRAULIC SYMBOLS

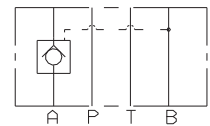

AM5UP.A

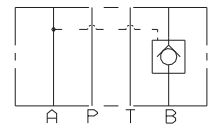

AM5UP.B

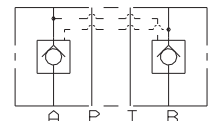

AM5UPAB

#### OVERALL DIMENSIONS

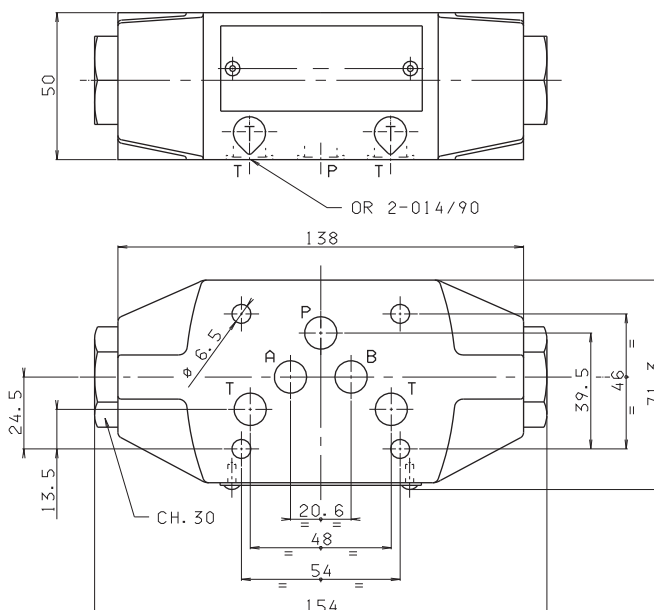

Support plane specifications

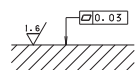

# AM5VM... / AM5VI... MODULAR MAX. PRESSURE VALVES CETOP 5



AM5VM / AM5VI...	
CMP20...	CARTRIDGE CATALOGUE
CMP30...	CARTRIDGE CATALOGUE
SCREWS AND STUDS	CAP. IV • 36

AM5VM type pressure regulating valves are available within operating range 7 ÷ 350 bar. Adjustment is by means of a grub screw or a plastic knob. They are three basic versions: **AM5VM**, on single A or B lines, and on double A and B lines, with drainage on T; **AM5VMP**, on single P line, with drainage on T; **AM5VI**, on single A or B lines, and on double A and B lines, with crossed drainage on either A or B (see hydraulic symbols). Three spring types can be fitted on all versions, with calibrated ranges as shown in the unit specifications. Piloted operation cartridge type CMP30 is used on versions AM5VM and AM5VM.P (see ordering code), while on version AM5VI direct acting cartridge type CMP20 is used instead.

Max. operating pressure	350 bar
Setting ranges:	spring 1 50 bar
	spring 2 140 bar
	spring 3 350 bar
Max. flow	80 l/min
Hydraulic fluids	Mineral oils DIN 51524
Fluid viscosity	10 ÷ 500 mm <sup>2</sup> /s
Fluid temperature	-25°C ÷ 75°C
Ambient temperature	-25°C ÷ 60°C
Max. contamination level	class 10 in accordance with NAS 1638 with filter $\beta_{25} \geq 75$
Weight AM5VMA/B/P...	2,5 Kg
Weight AM5VMAB...	2,7 Kg
Weight AM5VIA/B...	5,7 Kg
Weight AM5VIAB...	5,9 Kg

4

## ORDERING CODE

<b>AM</b>	Modular valve
<b>5</b>	CETOP 5/NG10
<b>**</b>	<b>VM</b> = Maximum pressure <b>VI</b> = Maximum crossline relief
<b>**</b>	Adjustment on the lines AM.5.VM Version = <b>A / B / P / AB</b> AM.5.VI Version = <b>A / B / AB</b>
<b>*</b>	Type of adjustment <b>M</b> = Plastic knob <b>C</b> = Grub screw
<b>*</b>	Setting ranges at port A/B/P CMP 30      CMP 20 (AM5VM only) (AM5VI only) <b>1</b> = max. 50 bar <b>1</b> = max. 50 bar    ( <b>white spring</b> ) <b>2</b> = max. 140 bar <b>2</b> = max. 140 bar   ( <b>yellow spring</b> ) <b>3</b> = max. 350 bar <b>3</b> = max. 250 bar   ( <b>green spring</b> )
<b>*</b>	Setting ranges at port B Omit if the setting is same as that at port A CMP 30      CMP 20 (AM5VM only) (AM5VI only) <b>1</b> = max. 50 bar <b>1</b> = max. 50 bar    ( <b>white spring</b> ) <b>2</b> = max. 140 bar <b>2</b> = max. 140 bar   ( <b>yellow spring</b> ) <b>3</b> = max. 350 bar <b>3</b> = max. 250 bar   ( <b>green spring</b> )
<b>**</b>	<b>00</b> = No variant <b>V1</b> = Viton
<b>3</b>	Serial No.

For the minimum permissible setting pressure depending on the spring, see the minimum pressure setting curve.

## HYDRAULIC SYMBOLS

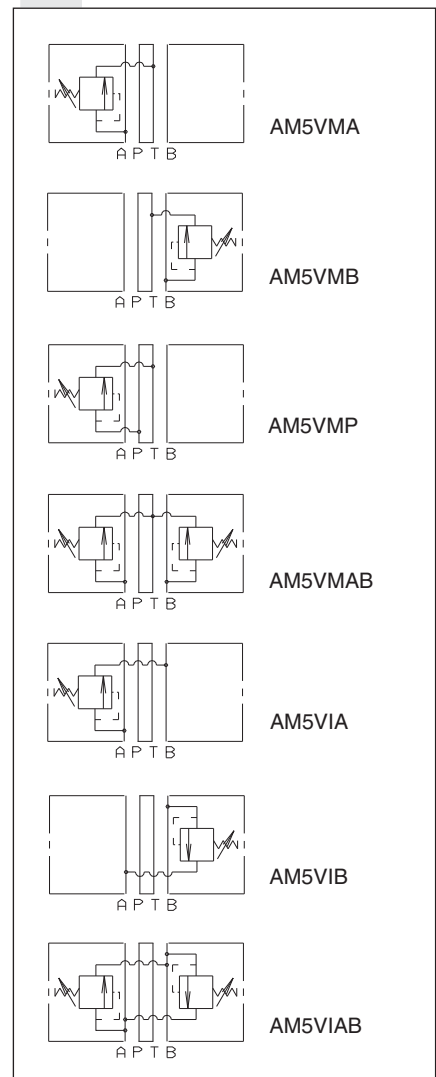

**PRESSURE - FLOW RATE  
FOR CMP30**

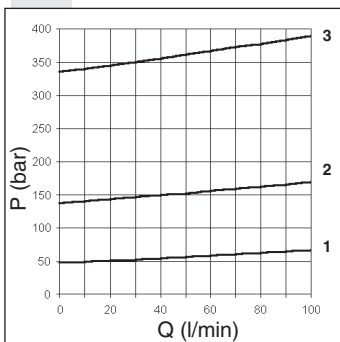

**MINIMUM SETTING PRESSURE  
FOR CMP30**

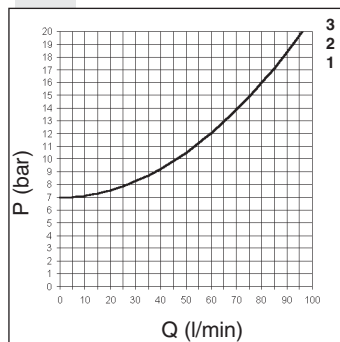

# AM5VM... / AM5VI... MODULAR MAX. PRESSURE VALVES CETOP 5

## OVERALL DIMENSIONS

### AM5VMAB...

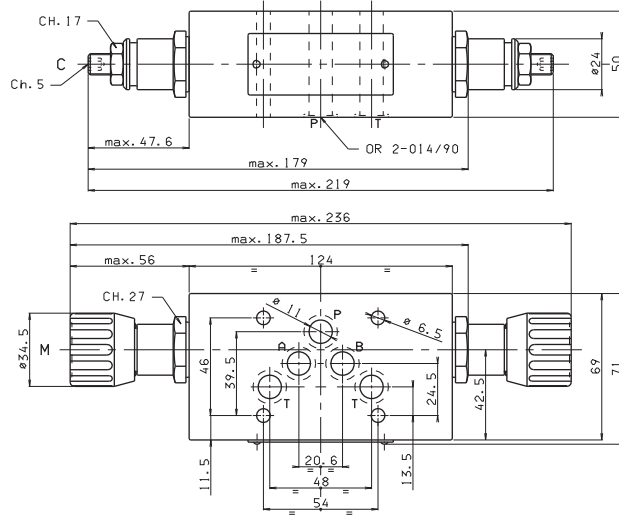

Type of adjustment

**M** Plastic knob

**C** Grub screw

Support plane specifications

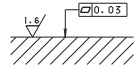

4

### AM5VMP...

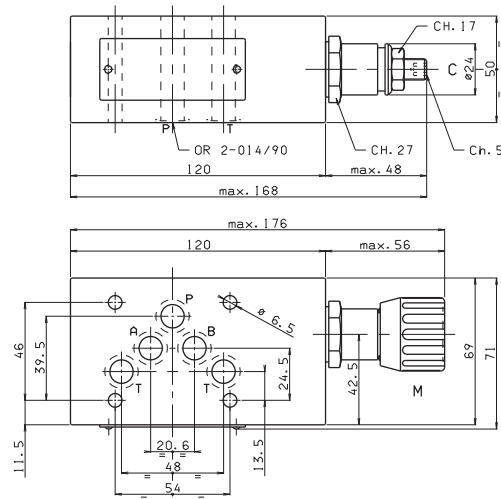

Type of adjustment

**M** Plastic knob

**C** Grub screw

Support plane specifications

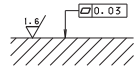

### AM5VIAB...

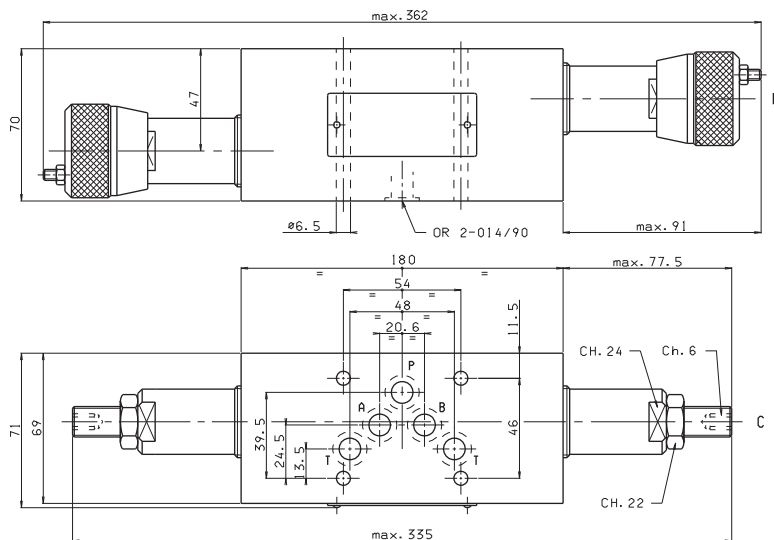

Type of adjustment

**M** Plastic knob

**C** Grub screw

Support plane specifications

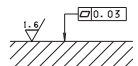

# AM5CP... MODULAR BACK PRESSURE VALVES CETOP 5



**AM5CP...**  
CMP20... CARTRIDGE CATALOGUE  
SCREWS AND STUDS CAP. IV • 36

Back pressure valves type AM.5.CP are direct acting damped maximum pressure in-line valves fitted with bypass non-return valves. They are obtainable within the adjustable range 2 ÷ 250 bar.

Adjustment is by means of a grub screw or a plastic knob, on ports A or B (single), or on AB double.

The cartridge is direct acting type CMP.20.

These valves are especially used on vertical working cylinders with dragging loads.

**For the minimum permissible setting pressure depending on the spring, see the minimum pressure setting curve**

Max. operating pressure	350 bar
Setting ranges:	spring 1 30 bar
	spring 2 140 bar
	spring 3 250 bar
Max. flow	80 l/min
Hydraulic fluids	Mineral oils DIN 51524
Fluid viscosity	10 ÷ 500 mm <sup>2</sup> /s
Fluid temperature	-25°C ÷ 75°C
Ambient temperature	-25°C ÷ 60°C
Max. contamination level	class 10 in accordance with NAS 1638 with filter $\beta_{25} \geq 75$
Weight AM5CPA/B...	5,3 Kg
Weight AM5CPAB...	7,2 Kg

## ORDERING CODE

4

- AM** Modular valve
- 5** CETOP 5/NG10
- CP** Back pressure valve
- \*\*** Control on lines **A / B / AB**
- \*** Type of adjustment  
M = Plastic knob  
C = Grub screw
- \*** Setting ranges  
1 = max. 30 bar (**white spring**)  
2 = max. 140 bar (**yellow spring**)  
3 = max. 250 bar (**green spring**)
- \*\*** 00 = No variant  
V1 = Viton
- 3** Serial No.

## HYDRAULIC SYMBOLS

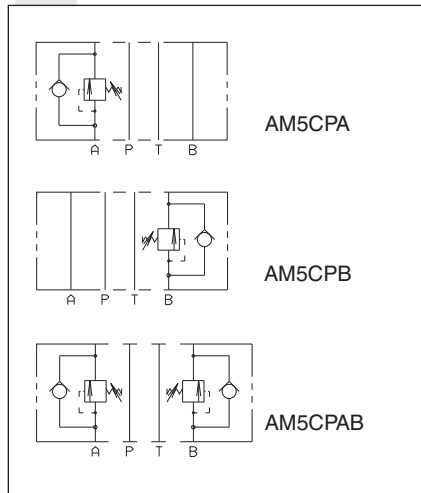

## PRESSURE - FLOW RATE

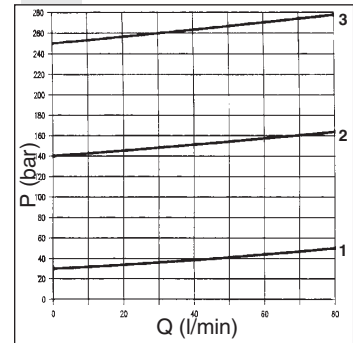

## MINIMUM SETTING PRESSURE

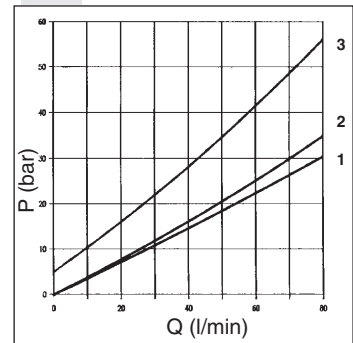

## OVERALL DIMENSIONS

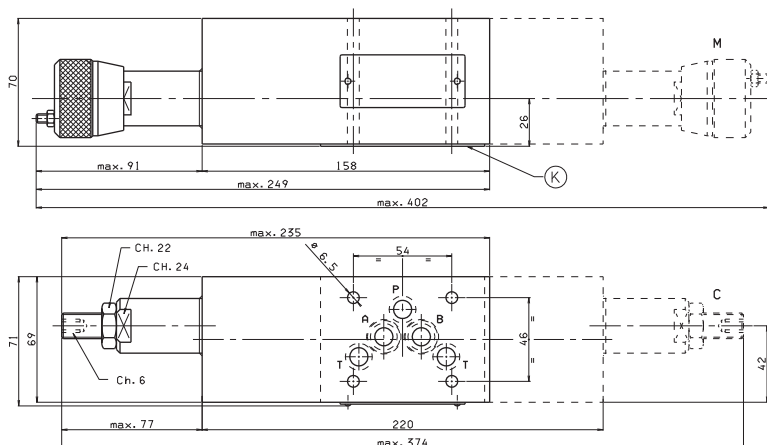

K = OR plate

Type of adjustment

M Plastic knob

C Grub screw

Support plane specifications

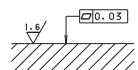



# AM5VR... MODULAR PRESSURE REDUCING VALVES WITH RELIEVING - PILOT OPERATED CETOP 5

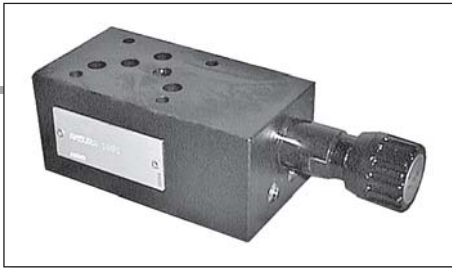

**AM5VR...**  
CVR20... CARTRIDGE CATALOGUE  
SCREWS AND STUDS CAP. IV • 36

These pressure reducing valves ensure a minimum pressure variation on the P or A port with changing flow rate up to 90 l/min.

Three spring types allow adjustment with the range 7 ÷ 250 bar. Manual adjustment is available by a grub screw or plastic knob.

The RELIEVING SYSTEM inside the valve AM5VR allows the passage from the setting pressure line to T line of the flow through the valve to avoid the increasing of pressure in the reduced-pressure line by diverting exceeding flow to reservoir.

A by pass module with check valve for free flow from A to AR port (see hydraulic symbol) is available.

Max. operating pressure	350 bar
Setting ranges:	spring 1 60 bar
	spring 2 120 bar
	spring 3 250 bar

<b>Maximum allowed <math>\Delta p</math> pressure between the inlet and outlet pressure</b>	<b>150 bar</b>
Max. flow	90 l/min
Draining on port T	0,5 ÷ 0,7 l/min
Hydraulic fluids	Mineral oils DIN 51524
Fluid viscosity	10 ÷ 500 mm <sup>2</sup> /s
Fluid temperature	-25°C ÷ 75°C
Ambient temperature	-25°C ÷ 60°C
Max. contamination level	class 10 in accordance with NAS 1638 with filter $\beta_{25} \geq 75$
Weight	3,73 Kg
Weight by-pass version	6,56 Kg

## ORDERING CODE

<b>AM</b>	Modular valve
<b>5</b>	CETOP 5/NG10
<b>VR</b>	Pilot operated pressure reducing valve with relieving
<b>*</b>	Control on lines P = Drain on T A = Drain on T D = Drain on B reduct pressure on A
<b>*</b>	Drain connection E = External (only for control on the P line) I = Internal (Standard)
<b>B</b>	Version with by-pass on line A only <b>Omit if not required</b>
<b>*</b>	Type of adjustment M = Plastic knob C = Grub screw
<b>*</b>	Setting ranges 1 = max. 60 bar ( <b>white spring</b> ) 2 = max. 120 bar ( <b>yellow spring</b> ) 3 = max. 250 bar ( <b>green spring</b> )
<b>**</b>	00 = No variant V1 = Viton
<b>1</b>	Serial No.

## HYDRAULIC SYMBOLS

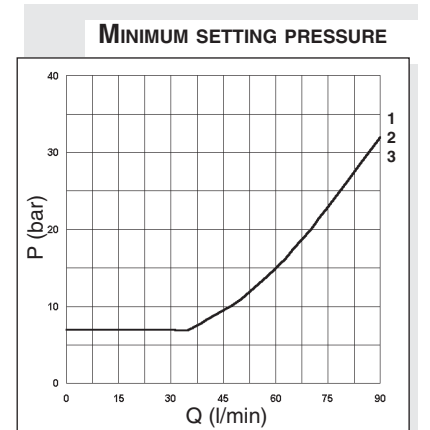
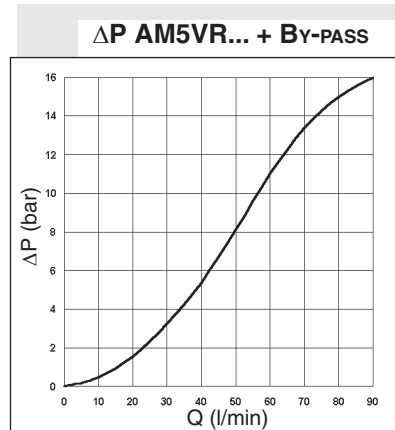
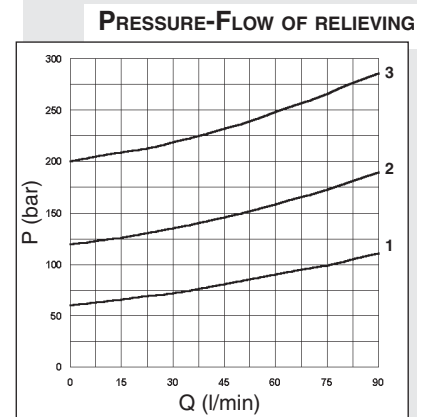
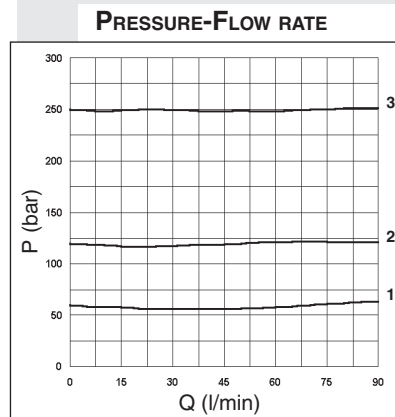
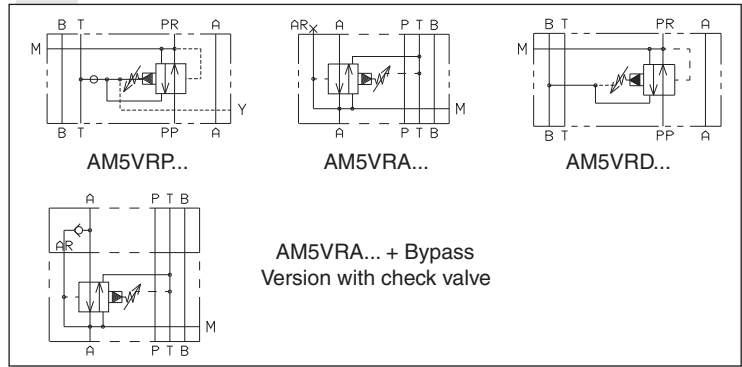

To change valves AM5VRP... from internal to external drainage it is necessary:

- screw out the plug on the Y port
- screw out the plug T.C.E.I. M8x1 from the body
- screw in a screw S.T.E.I. M6
- rescrew the T.C.E.I. M8x1 plug on the body

**NOTE:** the external draining can be used as a piloting line (please, contact our technical department for other informations)

Curves n° 1 - 2 - 3 = setting ranges

The fluid used is a mineral oil with a viscosity of 46 mm<sup>2</sup>/s at 40°C. The tests have been carried out at a fluid temperature of 50°C.

# AM5VR... MODULAR PRESSURE REDUCING VALVES WITH RELIEVING - PILOT OPERATED CETOP 5

## OVERALL DIMENSIONS

### AM5VRP... / AM5VRD...

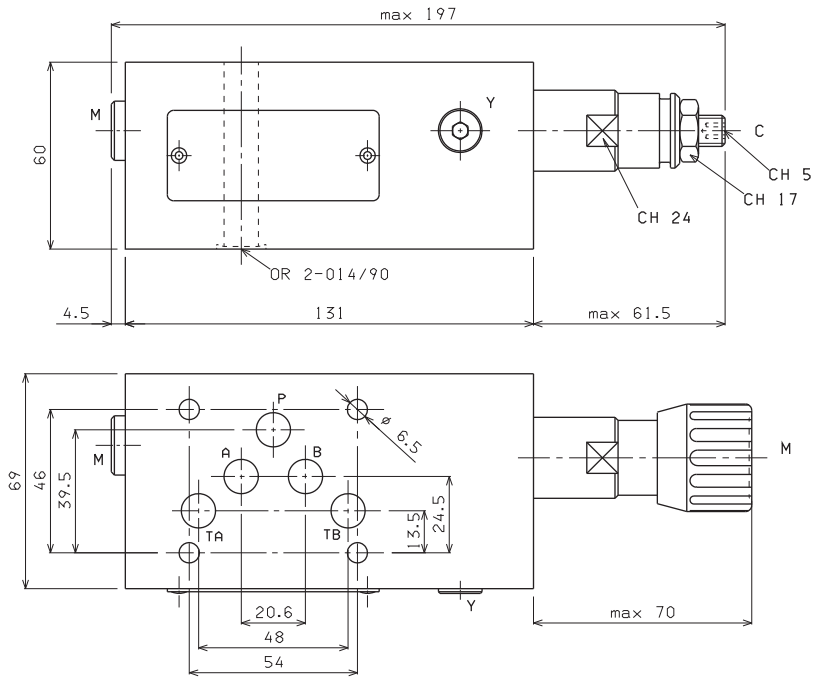

### AM5VRA... + BYPASS

(B) By-pass (optional)  
Ordering code:  
V89460000  
(if ordered separately)

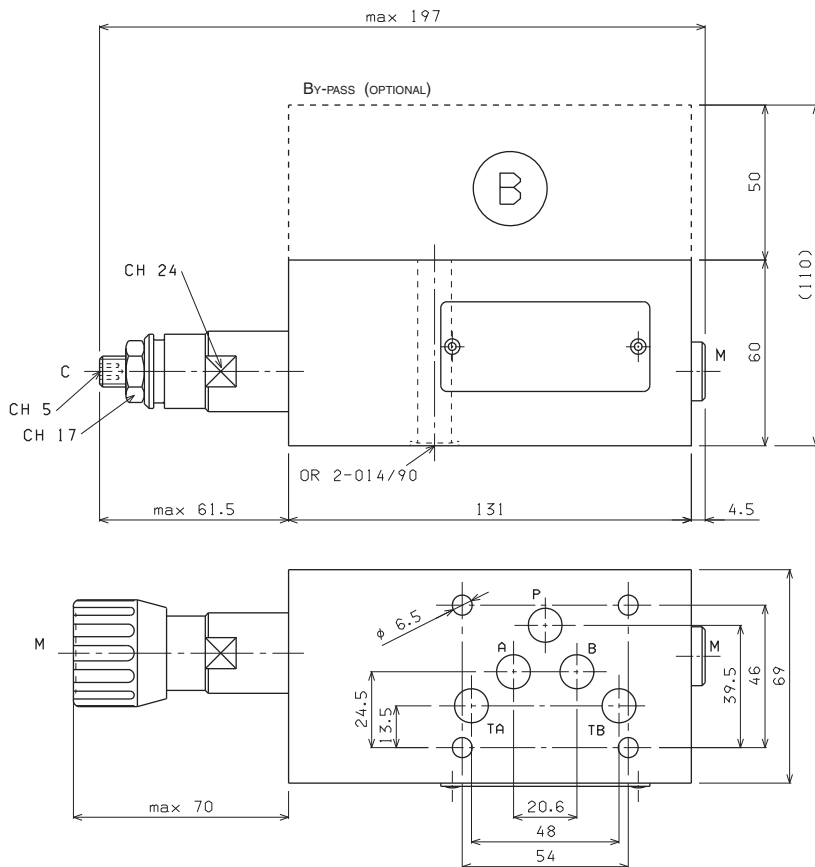

Type of adjustment

**M** Plastic knob

**C** Grub screw

Support plane  
specifications

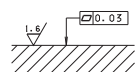

# AM5VS... MODULAR PRESSURE SEQUENCING VALVES CETOP 5

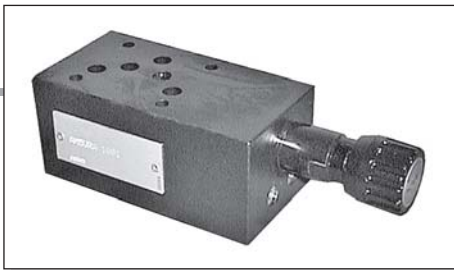

**AM5VS...**  
CVS20... CARTRIDGE CATALOGUE  
SCREWS AND STUDS CAP. IV • 36

The sequence valve are used to assure that a secondary circuit is pressurized when the setting pressure with a changing flow to up 90 l/min (see diagram).

Three spring types allow adjustment within the range 7 ÷ 250 bar. Manual adjustment is available by a grub screw or plastic knob.

The cartridge used is the "CVS" type.

Max. operating pressure	350 bar
Setting ranges:	spring 1 60 bar
	spring 2 120 bar
	spring 3 250 bar
Max. flow	90 l/min
Draining on port T	0,5 ÷ 0,7 l/min
Hydraulic fluids	Mineral oils DIN 51524
Fluid viscosity	10 ÷ 500 mm <sup>2</sup> /s
Fluid temperature	-25°C ÷ 75°C
Ambient temperature	-25°C ÷ 60°C
Max. contamination level	class 10 in accordance with NAS 1638 with filter $\beta_{25} \geq 75$
Weight	3,73 Kg

## ORDERING CODE

<b>AM</b>	Modular valve
<b>5</b>	CETOP 5/NG10
<b>VS</b>	Sequencing valve
<b>*</b>	Drain connection E = External I = Internal (Standard)
<b>*</b>	Type of adjustment M = Plastic knob C = Grub screw
<b>*</b>	Setting ranges 1 = max. 60 bar (white spring) 2 = max. 120 bar (yellow spring) 3 = max. 250 bar (green spring)
<b>**</b>	00 = No variant V1 = Viton
<b>1</b>	Serial No.

The fluid used is a mineral oil with a viscosity of 46 mm<sup>2</sup>/s at 40°C. The tests have been carried out a fluid temperature of 50°C.

Curves n° 1 - 2 - 3 = setting ranges

## HYDRAULIC SYMBOL

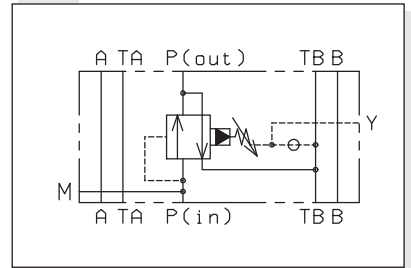

## PRESSURE-FLOW RATE

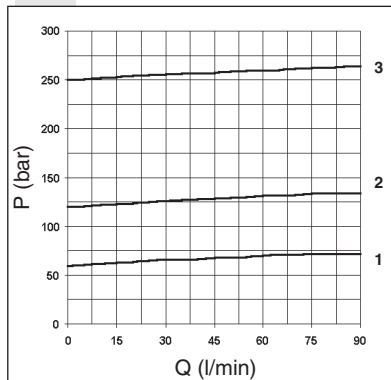

## MINIMUM SETTING PRESSURE

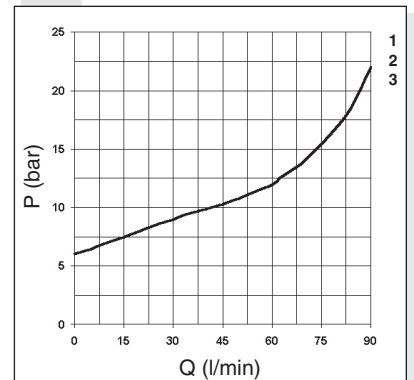

## OVERALL DIMENSIONS

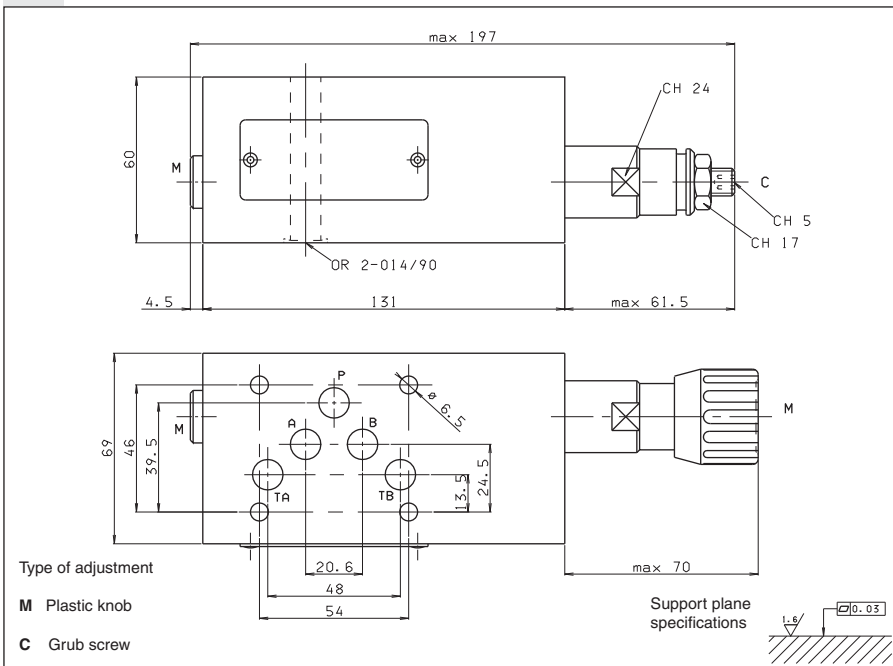

To change valves AM.5.VS... from internal to external drainage it is necessary:

- screw out the plug on the Y port
- screw out the plug T.C.E.I. M8x1 from the body
- screw in a screw S.T.E.I. M6
- rescrew the T.C.E.I. M8x1 plug on the body

NOTE: the external draining can be used as a piloting line (please, contact our technical department for other informations)

# AM5SH... MODULAR SHUTTLE VALVES CETOP 5



**AM5SH...**

SH03... CARTRIDGE CATALOGUE  
SCREWS AND STUDS CAP. IV • 36

Modular valves type AM5SH are actuator load pressure selecting units, as they are fitted with an integral shuttle valve cartridge which allows taking of the highest pressure signal to the external port via displacement of a ball. They are usually employed to signal the actuator load to the pressure compensator of a load sensing pump, or for the command of fail-safe brakes. For seat overall dimensions see cartridge shuttle type SH03.

Max. operating pressure	350 bar
Max. flow at the cartridge	3 l/min
Max. flow at ports A/B/P/T	80 l/min
Hydraulic fluids	Mineral oils DIN 51524
Fluid viscosity	10 ÷ 500 mm <sup>2</sup> /s
Fluid temperature	-25°C ÷ 75°C
Ambient temperature	-25°C ÷ 60°C
Max. contamination level	class 10 in accordance with NAS 1638 with filter $\beta_{25} \geq 75$
Weight	2,1 Kg
Cartridge tightening torque	20÷30 Nm/2÷3 Kgm

4

### ORDERING CODE

- AM** Modular valve
- 5** CETOP 5/NG10
- SH** Cartridge shuttle
- \*\*** **00** = No variant  
**V1** = Viton
- 1** Serial No.

### PRESSURE DROPS ( $\Delta p$ ) ON THE SHUTTLE VALVE

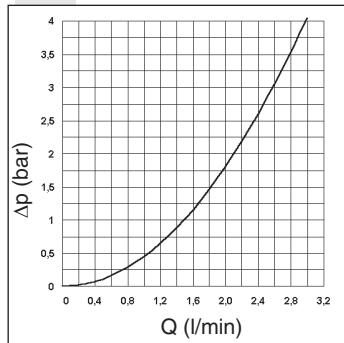

### HYDRAULIC SYMBOL

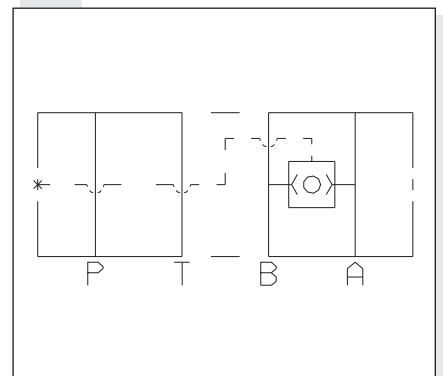

### OVERALL DIMENSIONS

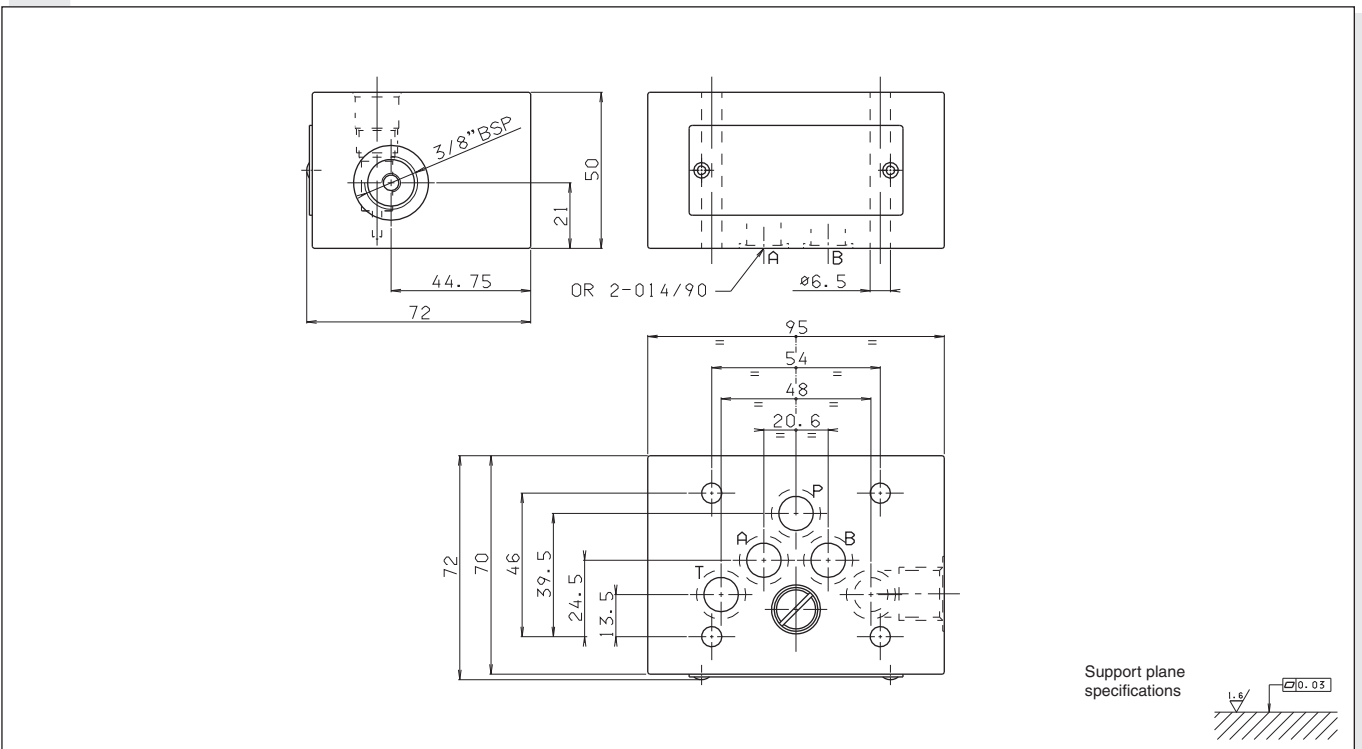

Support plane specifications

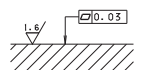



**AM5QF...**

SCREWS AND STUDS

CAP. IV • 36

## AM5QF... MODULAR FLOW REGULATOR CETOP 5

AM.5.QF type one way non-compensated throttle valve are fitted with an O-Ring mounting plate which allows its assembly for either input or output regulation. Adjustment is obtained by means of a grub screw or a plastic knob. They are available in the four regulating configurations shown in the hydraulic diagrams.

These valves are supplied with related hydraulic scheme. In case of inversion of rated flow direction, turn valve 180° right or left (attention: in this case the label will appear upside down with A and B inverted).

Max. operating pressure	350 bar
Flow rate regulation	on 9 screw turns
Max. flow	100 l/min
Hydraulic fluids	Mineral oils DIN 51524
Fluid viscosity	10 ÷ 500 mm <sup>2</sup> /s
Fluid temperature	-25°C ÷ 75°C
Ambient temperature	-25°C ÷ 60°C
Max. contamination level	class 10 in accordance with NAS 1638 with filter $\beta_{25} \geq 75$
Weight	3,5 Kg

### ORDERING CODE

<b>AM</b>	Modular valve
<b>5</b>	CETOP 5/NG10
<b>QF</b>	Non compensated throttle valve
<b>**</b>	Control on lines <b>A / B / P / AB</b>
<b>*</b>	Type of adjustment <b>M</b> = Plastic knob <b>C</b> = Grub screw
<b>**</b>	<b>00</b> = No variant <b>V1</b> = Viton
<b>5</b>	Serial No.

### FLOW RATE

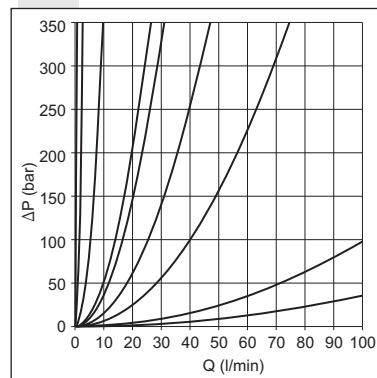

Each curve represents the flow rate adjustment for each screw turns, starting from the closed position.

### FREE FLOW

#### TOWARDS CHECK VALVE

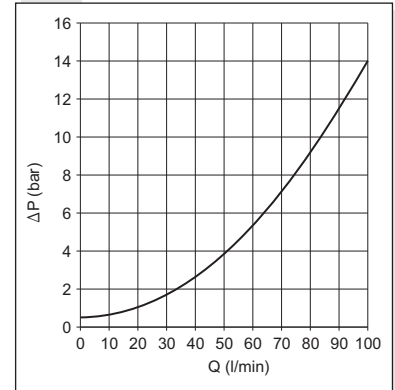

4

### HYDRAULIC SYMBOLS

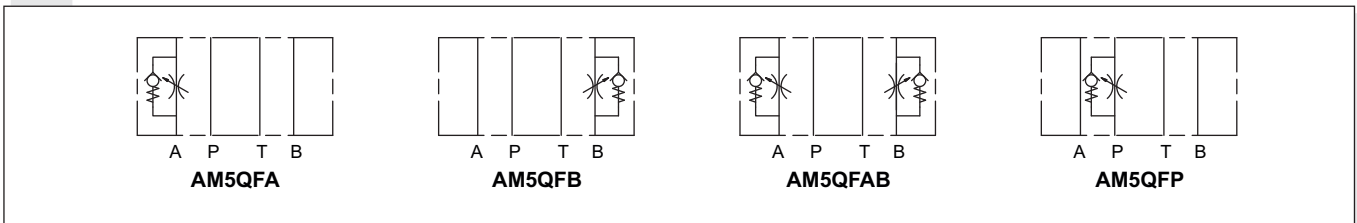

# AM5QF... MODULAR FLOW REGULATOR CETOP 5

## OVERALL DIMENSIONS

### AM5QF/ A / B / AB

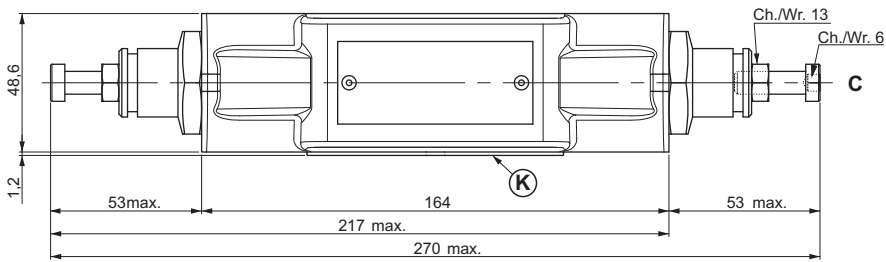

per versioni con regolazione su due vie (AB)  
versions with double regulation (AB)

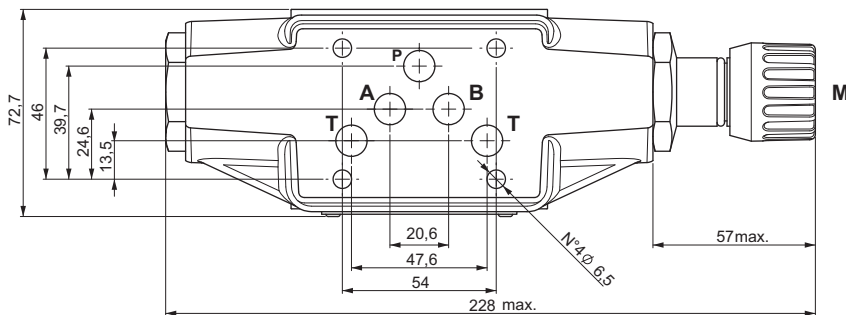

per versioni con regolazione su una singola via (A o B)  
versions with single regulation (A or B)

K = OR plate

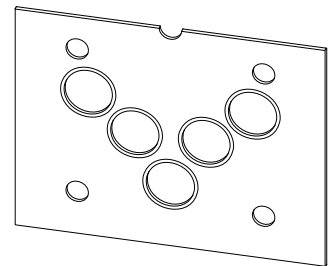

Type of adjustment

M Plastic knob

C Grub screw

### AM5QF/ P

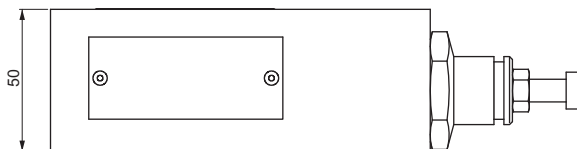
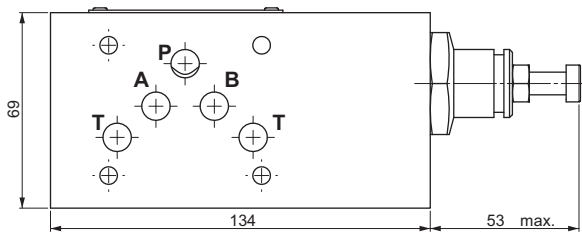

Support plane  
specifications

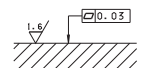

4

# AM88... MODULAR COMPENSATED FLOW CONTROL ASSEMBLY CETOP 5



This is an intermediate block (AM88) for modular mounting of one or two compensated flow rate regulators QC3...

The flow regulator type QC32 must be ordered separately.

Max. operating pressure	320 bar
Hydraulic fluids	Mineral oils DIN 51524
Fluid viscosity	10 ÷ 500 mm <sup>2</sup> /s
Fluid temperature	-25°C ÷ 75°C
Ambient temperature	-25°C ÷ 60°C
Max. contamination level	class 10 in accordance with NAS 1638 with filter $\beta_{25} \geq 75$
Weight	2,75 Kg

AM88...	
QC32...	CAP. III • 2
SCREWS AND STUDS	CAP. IV • 36

### ORDERING CODE

<b>AM</b>	Modular valve
<b>88</b>	Size
<b>**</b>	Control on lines <b>A / B / P / T / PT* / AB</b> For A1 / B1 / A1B1 see table "Hydraulic symbols"
<b>**</b>	<b>00</b> = No variant <b>V1</b> = Viton
<b>3</b>	Serial No.

### HYDRAULIC SYMBOLS

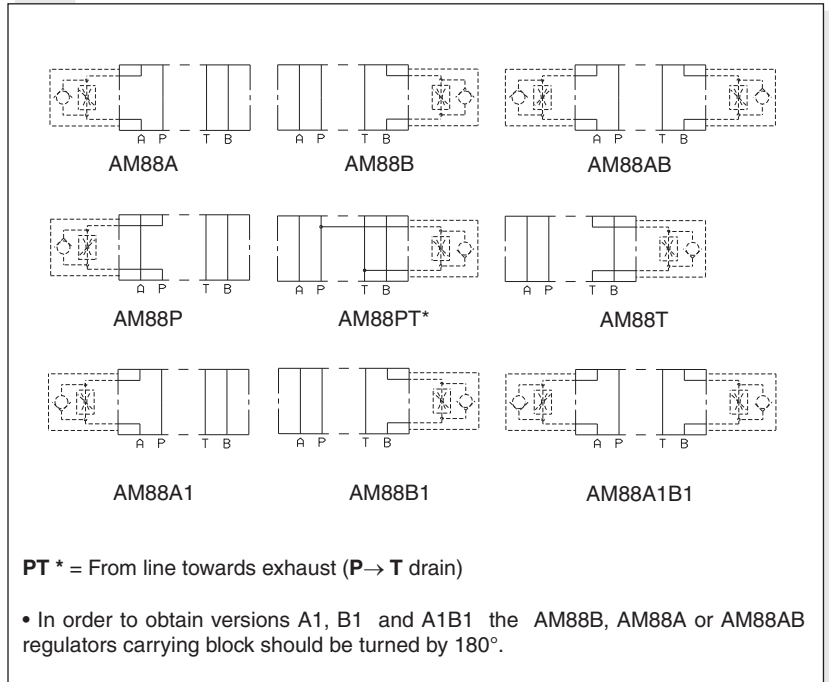

### OVERALL DIMENSIONS

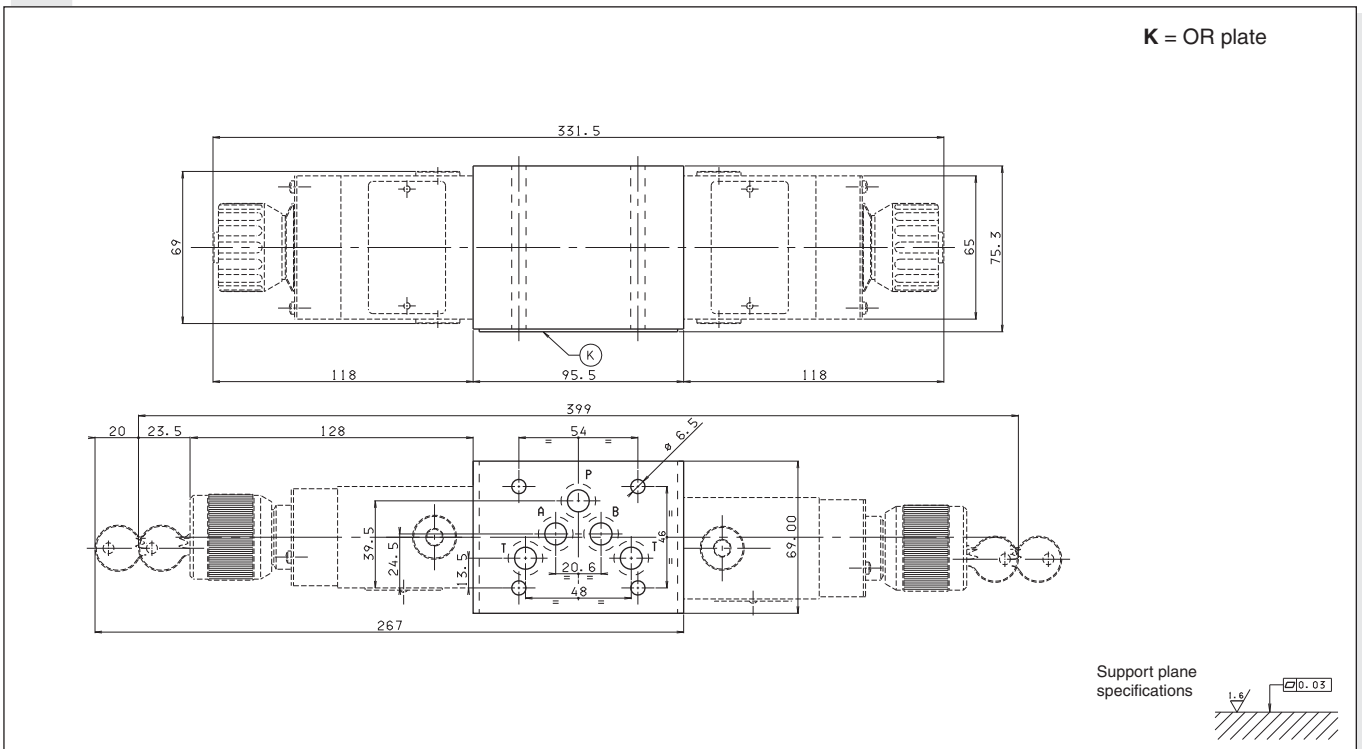

# A88... MODULAR FLOW CONTROL VALVES

## FAST / SLOW ASSEMBLY CETOP 5



This is a modular assembly ON/OFF solenoid valve which, by fitting a suitable 2 way regulator, allows two speed operation in the same system via an electrical changeover command.

Max. operating pressure	320 bar
Hydraulic fluids	Mineral oils DIN 51524
Fluid viscosity	10 ÷ 500 mm <sup>2</sup> /s
Fluid temperature	-25°C ÷ 75°C
Ambient temperature	-25°C ÷ 60°C
Max. contamination level	class 10 in accordance with NAS 1638 with filter β <sub>25</sub> ≥ 75
Weight with a DC solenoid	4,2 Kg

**The flow rate regulator type QC32 must be ordered separately.**

**The limit of use curves have been obtained with the regulator fully closed, and those same limits improve gradually with the opening of the regulator.**

The test have been carried out at operating temperature, with a voltage 10% lower than rated voltage and with a fluid temperature of 50 degrees C. The fluid used was a mineral based oil with a viscosity of 46 mm<sup>2</sup>/sec at 40 degrees C.

• Solenoids used are standard type A16 for DC voltage.

A88...	
"A16" DC COILS	CAP. I • 40
STANDARD CONNECTORS	CAP. I • 20
QC32...	CAP. III • 2
SCREWS AND STUDS	CAP. IV • 36

### ORDERING CODE

4

- A** Speed control valve
- 88** Size
- E** Electrical operator
- \*\*\*** **120** = Normally open  
**121** = Normally closed  
See table "Hydraulic symbols"
- \*** Control on lines **A/B/P/T** (see symbols)  
The interface holder "H" must be turned by 180° in order to obtain the **A1** and **B1** versions.
- \*** Voltage : see tab.1
- \*\*** Variants: see tab.2
- 3** Serial No.

### LIMITS OF USE DC SOLENOID

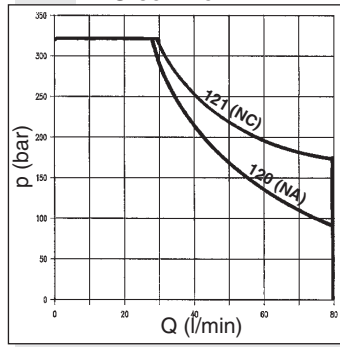

### FREE FLOW THROUGH SPOOL

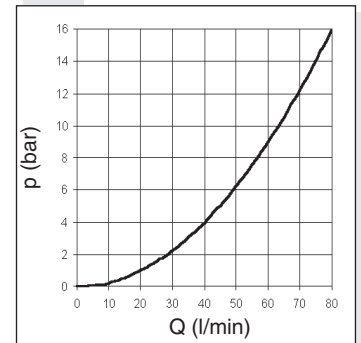

### HYDRAULIC SYMBOLS

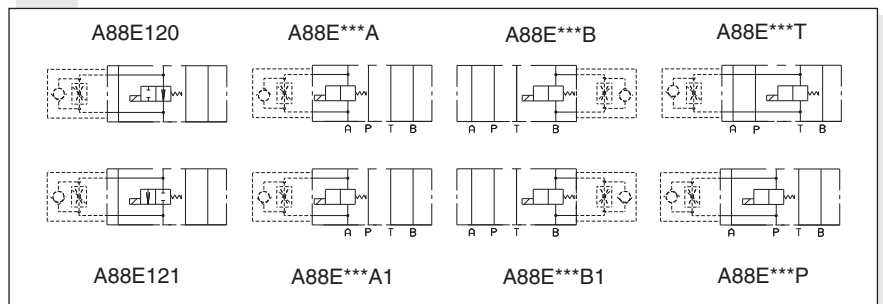

**TAB.1 - A16 COIL (45W)**

DC VOLTAGE **	
<b>L</b>	12V
<b>M</b>	24V
<b>N</b>	48V*
<b>P</b>	110V*
<b>Z</b>	102V*
<b>X</b>	205V*
<b>W</b>	Without DC coil

115Vac/50Hz  
120Vac/60Hz with rectifier

230Vac/50Hz  
240Vac/60Hz with rectifier

Voltage codes are not stamped on the plate, their are readable on the coils.

\* Special voltage  
\*\* Technical data see Cap. VII • 7

**TAB.2 - VARIANTS**

No variant (without connectors)	S1(*)
Viton	SV(*)
Other variants available on request	

(\*) Coils with Hirschmann connection supplied without connectors. The connectors can be ordered separately, Cap. I • 20.

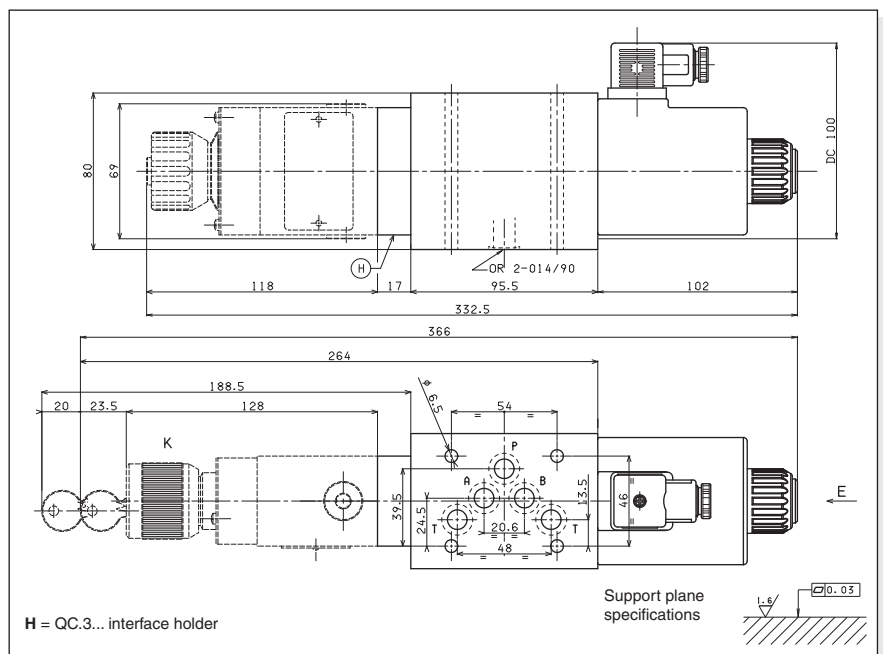



# AM5RGT... MODULAR VALVES FOR REGENERATIVE CIRCUIT CETOP 5



AM5RGT...

SCREWS AND STUDS

CAP. IV • 36

This modular system produces a regenerative circuit to increasing the actuator (differential cylinder) exit speed as shown in the diagram. In particular, if a cylinder is used with a 2:1 ratio for operating surfaces, the exit and re-entry speeds are the same.

Max. operating pressure	350 bar
Max. flow at port A/B/P/T	70 l/min
Hydraulic fluids	Mineral oils DIN 51524
Fluid viscosity	10 ÷ 500 mm <sup>2</sup> /s
Fluid temperature	-25°C ÷ 75°C
Ambient temperature	-25°C ÷ 60°C
Max. contamination level	class 10 in accordance with NAS 1638 with filter $\beta_{25} \geq 75$
Weight	2,1 Kg

### ORDERING CODE

<b>AM</b>	Modular valve
<b>5</b>	CETOP 5/NG10
<b>RGT</b>	For regenerative circuit
<b>A</b>	Size of check valves 1/2"BSP
<b>1</b>	Opening pressure 1 bar
<b>**</b>	<b>00</b> = No variant <b>V1</b> = Viton
<b>1</b>	Serial No.

### PRESSURE DROPS B → P

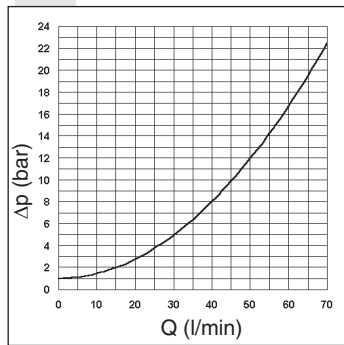

### HYDRAULIC SYMBOL

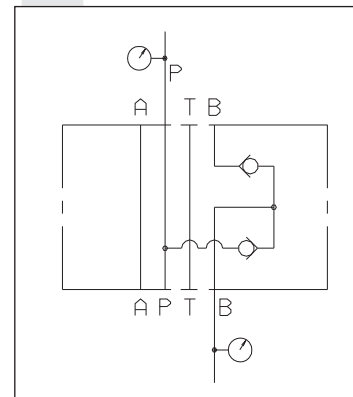

4

### OVERALL DIMENSIONS

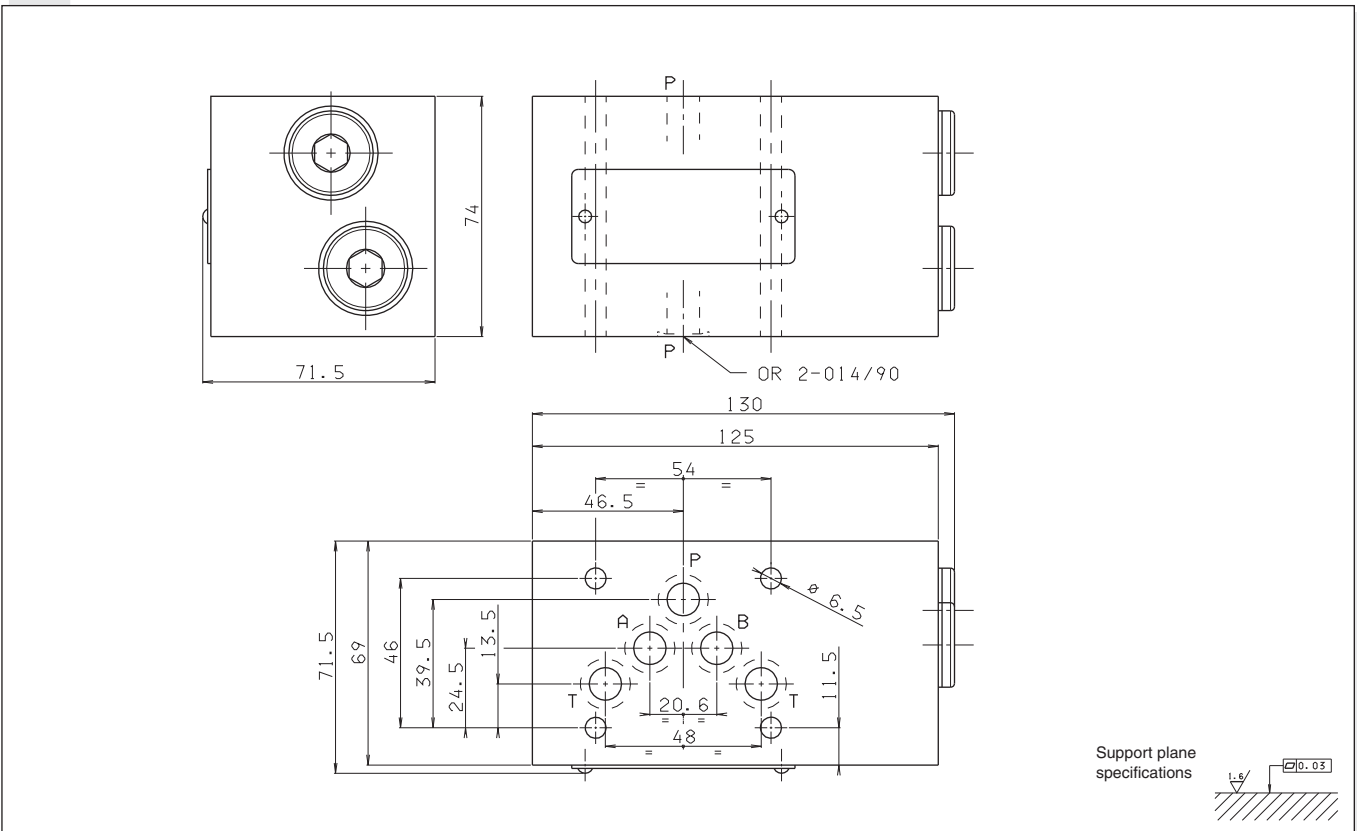

# TABLE OF SCREW AND STUDS FOR MOUNTING CETOP 5/NG10

## OVERALL DIMENSIONS

Tighten M27050002 to a torque of **8 Nm / 0.8 Kgm max.**

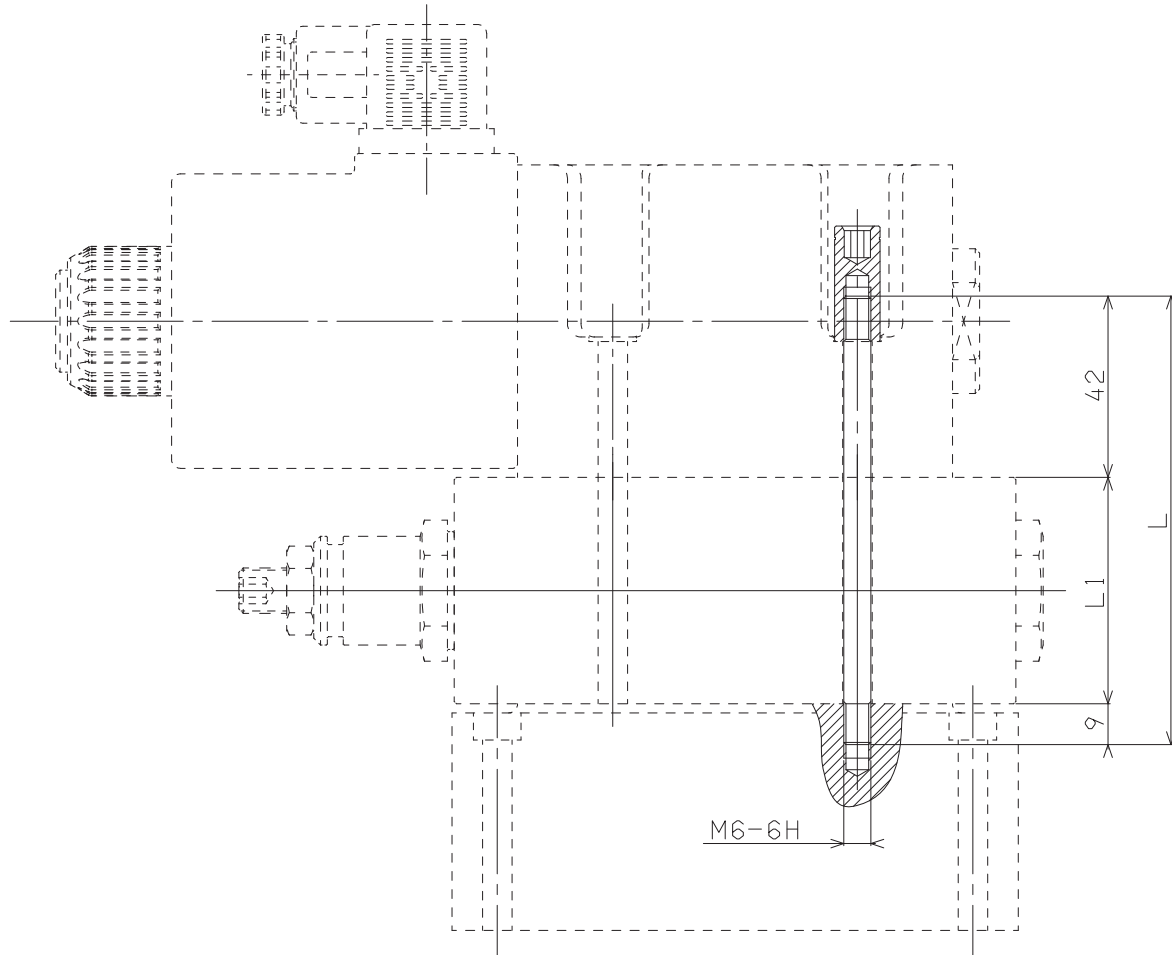

SCREWS T.C.E.I CODE	L mm	L1* mm	COMPOSITION	Q.TY	SPECIAL NUTS CODE
Q26074090	40	—	AD5...	4	—
Q26074098	90	50	AD5... + 1 AM5... (ISO)	4	
Q26074301	100	60	AD5... + AM5VR	4	
Q26074302	110	70	AD5... + AM5VI	4	
Q26074099	120	80	AD5... + A88	4	
M80150004	150	100	AD5... + 2 AM5... (ISO)	4	V89250000 (No. 20 nuts kit)
M80150012	160	110	AD5... + AM5VR + AM5... (ISO)	4	
M80150010	180	130	AD5... + A88... + AM5... (ISO)	4	
M80150006	190	140	AD5... + A88... + AM5VR	4	
M80150011	200	150	AD5... + 3 AM5... (ISO)	4	

\* Indicative overall dimensions valves composition

# AM7UP... MODULAR PILOT OPERATED CHECK VALVES CETOP 7



AM.7.UP...

AM7UP type modular check valves allow free flow in one direction by lifting a seated poppet, while in the opposite direction the fluid can return by means of a small piston piloted by the other line pressure (piloted side).

The cast valve body allows limited pressure drops during the fluid flow through the various P/A/B/T lines.

They are available on single A or B lines, and on double A and B lines (see hydraulic symbols).

Max. operating pressure	350 bar
Opening pressure	2 bar
Piloting ratio	1 : 11,7
Max. flow	250 l/min
Hydraulic fluids	Mineral oils DIN 51524
Fluid viscosity	10 ÷ 500 mm <sup>2</sup> /s
Fluid temperature	-20°C ÷ 80°C
Ambient temperature	-20°C ÷ 50°C
Max. contamination level	class 10 in accordance with NAS 1638 with filter $\beta_{25} \geq 75$
Weight	7,2 Kg

## ORDERING CODE

<b>AM</b>	Modular valve
<b>7</b>	CETOP 7/NG16
<b>UP</b>	Piloted check valve
<b>**</b>	Control on lines <b>A / B / AB</b>
<b>2</b>	Minimum opening pressure 2 bar
<b>**</b>	<b>00</b> = No variant <b>V1</b> = Viton
<b>1</b>	Serial No.

## HYDRAULIC SYMBOLS

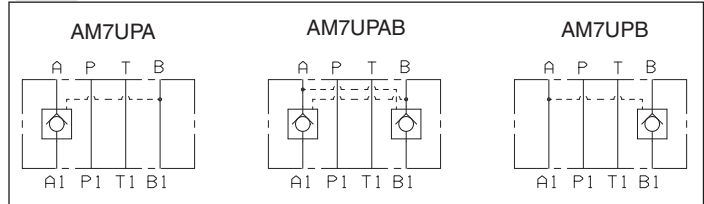

**Curve 1** = A1→A  
B1→B



**Curve 2** = A→A1  
B→B1



**Curve 3** = A1→A (AM7UPB)  
B1→B (AM7UPA)

**Curve 4** = P1→T  
T1→P

The fluid used is a mineral oil with a viscosity of 46 mm<sup>2</sup>/s at 40°C. The tests have been carried out a fluid temperature of 50°C.

## PRESSURE DROPS ΔP-Q

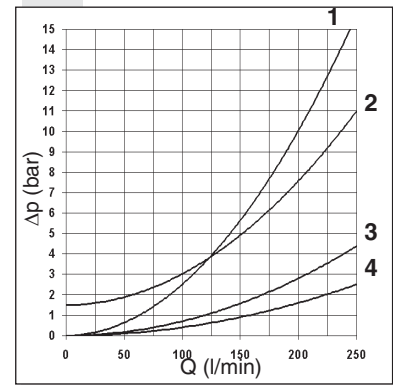

## OVERALL DIMENSIONS

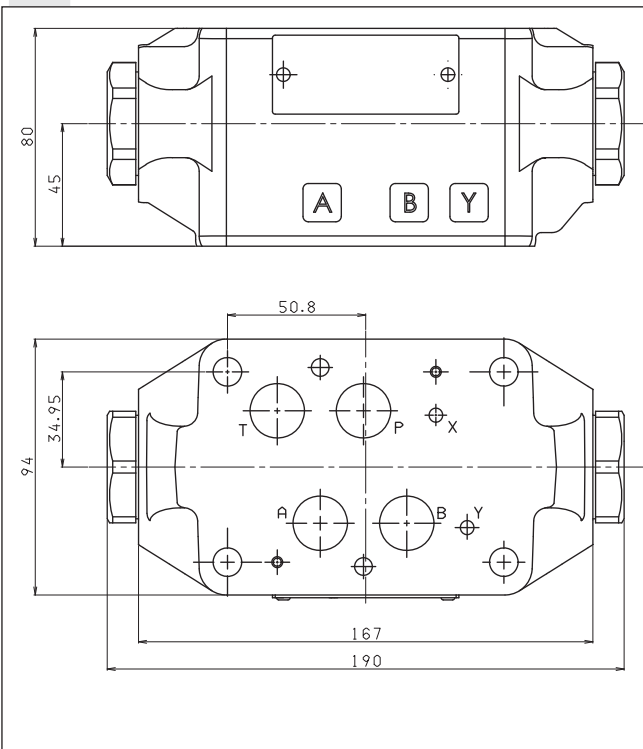

- Valve fixing:  
n° 4 screws T.C.E.I. M10 - Tightening torque 40 Nm  
n° 2 screws T.C.E.I. M6 - Tightening torque 8 Nm  
The longer of the screws depends on the type of assembly used.  
Fixing screws UNI 5931 with material specifications 12.9

- Seals:  
n° 4 pieces OR 2-118/90SH PARKER (type 130)  
n° 2 pieces OR 2-013/90SH PARKER (type 2043)

## CETOP 7 (4.2-4-07) MOUNTING SURFACE

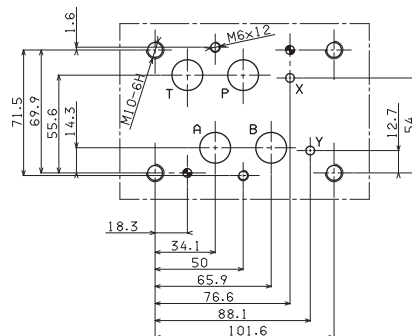

Support plane specifications

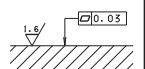



AM7QF...

## AM7QF... MODULAR FLOW REGULATOR CETOP 7

AM7QF type one way non-compensated throttle valve.

Adjustment is obtained by means of a grub screw. They are available in the three regulating configurations shown in the hydraulic diagrams.

All configurations have a built in check valve that allows reserve free flow.

Max. operating pressure	350 bar
Flow rate regulation	on 10 screw turns
Max. flow	250 l/min
Hydraulic fluids	Mineral oils DIN 51524
Fluid viscosity	10 ÷ 500 mm <sup>2</sup> /s
Fluid temperature	-20°C ÷ 80°C
Ambient temperature	-20°C ÷ 50°C
Max. contamination level	class 10 in accordance with NAS 1638 with filter $\beta_{25} \geq 75$
Weight AM7QF for A or B versions	7,35 Kg
Weight AM7QF for AB version	7,7 Kg

### ORDERING CODE

<b>AM</b>	Modular valve
<b>7</b>	CETOP 7/NG16
<b>QF</b>	Non compensated throttle valve
<b>**</b>	Control on lines <b>A / AB / B</b>
<b>*</b>	Type of adjustment <b>M</b> = Plastic knob <b>C</b> = Grub screw
<b>**</b>	<b>00</b> = No variant <b>V1</b> = Viton
<b>1</b>	Serial No.

### HYDRAULIC SYMBOLS

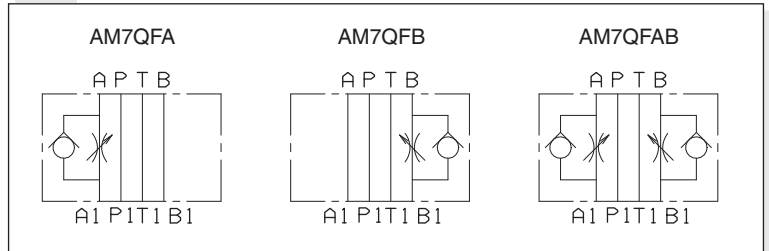

### PRESSURE DROPS $\Delta P-Q$

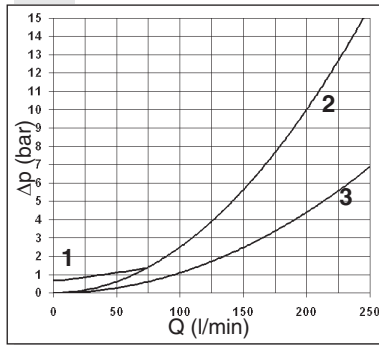

- Curve 1** = Regulator closed A → A1 / B → B1
- Curve 2** = Regulator open A → A1 / B → B1
- Curve 3** = Without regulator A → A1 (AM7QFB) / B → B1 (AM7QFA)

### REGULATED FLOW RATE

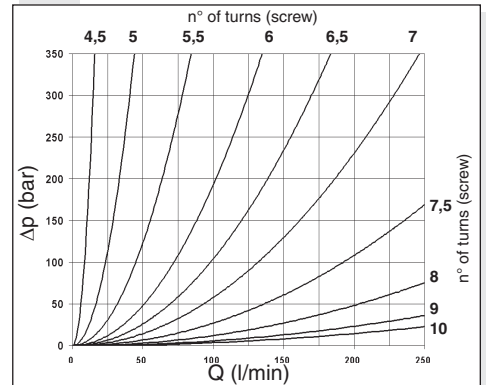

Regulated flow rate depending on No. of turns: from 4,5 to 10 turns (unscrewing).

### OVERALL DIMENSIONS

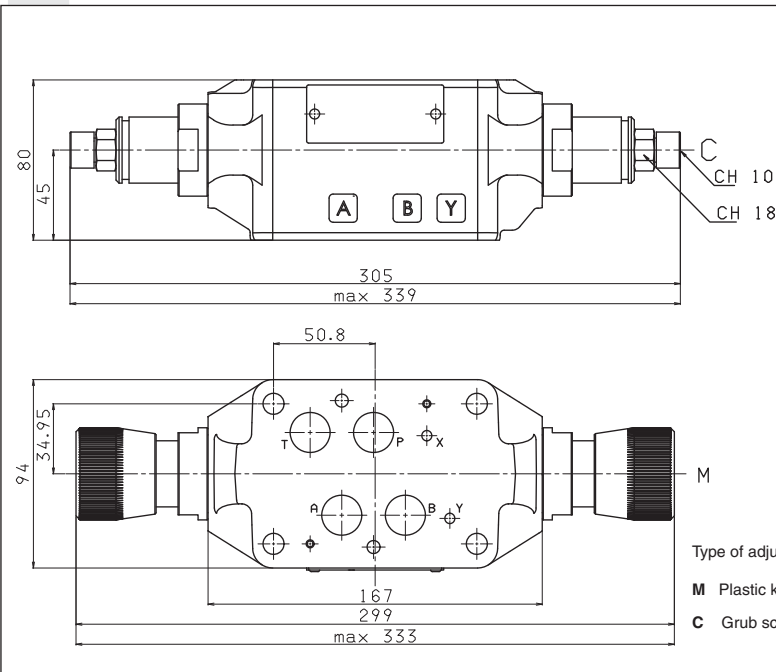

- Valve fixing:**  
n° 4 screws T.C.E.I. M10 - Tightening torque 40 Nm  
n° 2 screws T.C.E.I. M6 - Tightening torque 8 Nm  
The longer of the screws depends on the type of assembly used. Fixing screws UNI 5931 with material specifications 12.9.
- Seals:**  
n° 4 pieces OR 2-118/90<sub>SH</sub> PARKER (type 130)  
n° 2 pieces OR 2-013/90<sub>SH</sub> PARKER (type 2043)

### CETOP 7 (4.2-4-07) MOUNTING SURFACE

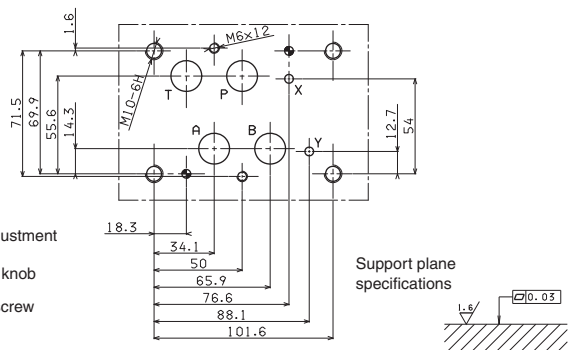

## ABBREVIATIONS

<b>AP</b>	HIGH PRESSURE CONNECTION
<b>AS</b>	PHASE LAG (DEGREES)
<b>BP</b>	LOW PRESSURE CONNECTION
<b>C</b>	STROKE (MM)
<b>CH</b>	ACROSS FLATS
<b>Ch</b>	INTERNAL ACROSS FLATS
<b>DA</b>	AMPLITUDE DECAY (dB)
<b>DP</b>	DIFFERENTIAL PRESSURE (BAR)
<b>F</b>	FORCE (N)
<b>I%</b>	INPUT CURRENT (A)
<b>M</b>	MANOMETER CONNECTION
<b>NG</b>	KNOB TURNS
<b>OR</b>	SEAL RING
<b>P</b>	LOAD PRESSURE (BAR)
<b>PARBAK</b>	PARBAK RING
<b>PL</b>	PARALLEL CONNECTION
<b>Pr</b>	REDUCED PRESSURE (BAR)
<b>Q</b>	FLOW (L/MIN)
<b>QP</b>	PUMP FLOW (L/MIN)
<b>SE</b>	ELASTIC PIN
<b>SF</b>	BALL
<b>SR</b>	SERIES CONNECTION
<b>X</b>	PILOTING
<b>Y</b>	DRAINAGE

## CARTRIDGE VALVES ISO 7368 (DIN 24342)



CARTRIDGE VALVES	CAP. V • 2
KEL 2/2 LOGIC ELEMENTS	CAP. V • 3
KEC COVERS	CAP. V • 5
COVERS WITH CMP	CAP. V • 10
KRA.16/25...	CAP. V • 13
PROXIMITY	CAP. V • 16

5

## CARTRIDGE VALVES CARTRIDGE SOLENOID VALVES WITH CHECK VALVE CARTRIDGE SOLENOID VALVES

SEE ALSO CATALOGUE  
CODE **DOC00044**

## 2/2 CARTRIDGE VALVES LOGIC ELEMENTS ACCORDING TO ISO 7368 (DIN 24342)



### 2/2 LOGIC ELEMENTS AND COVERS

KEL16/25...	CAP. V • 3
NG16/NG25 KEL SEATS	CAP. V • 4
KEC16/25	CAP. V • 5
KEC HYDRAULIC MOUNTING DIAGR.	CAP. V • 6
KEC16/25... WITH CMP	CAP. V • 10
C*P16/25...	CAP. V • 10
KRA16/25...	CAP. V • 13
KRA16/25... + AD3V...	CAP. V • 15
PROXIMITY FOR KRA	CAP. V • 16

Cartridge valves are basically composed of a cover and an operating unit insert in the ISO 7368 (DIN 24342) mounting frame. Each cartridge valve is characterized by 2 main way for the nominal flow (up to 350 l/min).

Nominal size (max. diameter)	16mm / 25mm
Max. opening pressure	350 bar
Max. nominal flow rate NG16	150 l/min
Max. nominal flow rate NG25	350 l/min
Fluid temperature	-20°C ÷ 75°C
Max. contamination level	class 10 in accordance with NAS 1638 with filter $\beta_{25} \geq 75$

By combining the various covers, operating units and connections within the block, many different functions can be obtained like: direct control, non-return, hydraulically piloted non-return, pressure control, flow rate regulation, as well as a combination of these same functions.

Thanks to their design features and operational flexibility, cartridge valves can be used to:

- speed-up machine cycles, and therefore increase productivity and efficiency (better response time compared to traditional valves);
- ensure minimum thermal dissipation (thanks to the passageway dimensions);
- reduce the hydraulic plant weight (thanks to the compact functions block);
- reduce to a minimum any internal leakages;
- provide ease of installation and serving.

The logic units 2/2 (Fig. 1) are formed by a cover (1), a functional unit (2), a spacer (3), a closure spring (4) and a guide bush (5) for each functional unit. Covers can be changed according to the required application and the functional unit can be combined with different springs in order to obtain various opening pressure.

### Covers

Covers serve to enclose the functional unit and to house the piloting ports and any incorporated valves or manual adjustment devices. Inside the cover are housed also the seats for the calibrated orifice used to optimize the valve opening/closed response time in according to the type of hydraulic system being implemented.

CETOP 3 interface covers are available, ready to accept solenoid valves or other modular valves for the implementation of particular control functions.

**The maximum allowed pressure is a function of the flow rate (max.400 bar).**

FIG. 1 - AREA RATIO

<b>A</b>	MAIN FLOW
<b>B</b>	MAIN FLOW
<b>X</b>	EXTERNAL PILOTING
<b>Z1</b>	EXTERNAL PILOTING
<b>Z2</b>	EXTERNAL PILOTING
<b>Y</b>	DRAINAGE
<b>A1</b>	A PORT EFFECTIVE CROSS SECTION
<b>A2</b>	B PORT EFFECTIVE CROSS SECTION
<b>A3</b>	SPRING CHAMBER EFFECTIVE CROSS SECTION

### ORIFICE FUNCTIONAL SYMBOLS

	STANDARD ORIFICE (ALREADY INSERTED) Ø 1mm (DIAMETER)
	A GRUB SCREW ORIFICE CAN BE INSERTED IN THE THREADED SEAT
	BLIND

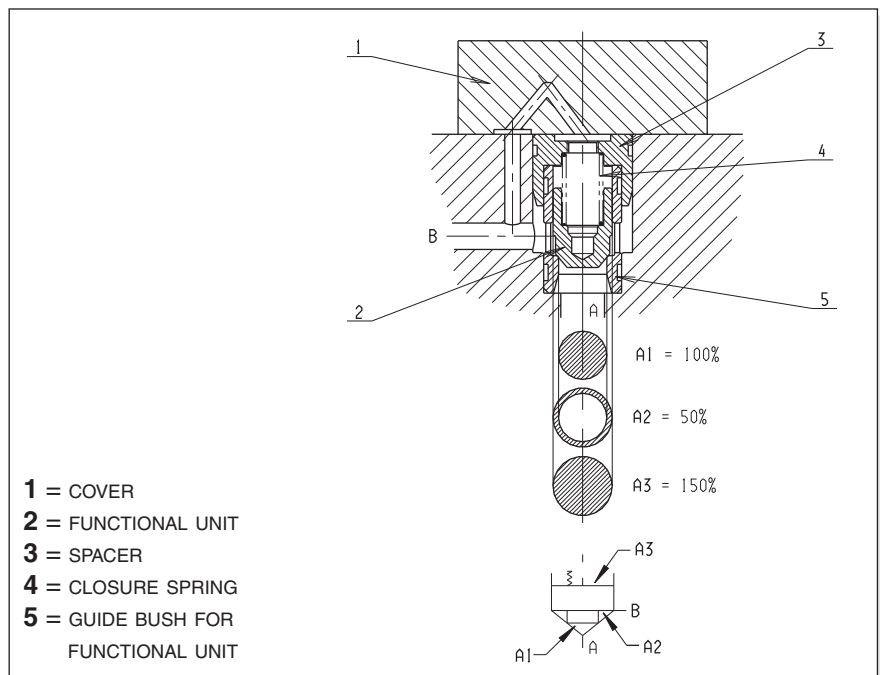

The logic unit operates as a function of the pressures acting on the relevant areas, and different opening pressures are obtained, depending on the dimensions of these areas.

A description of how to interpret the cartridge opening ratios is as follows:

- there are three relevant areas A1, A2, A3;
- area A1 is taken to represent 100%, i.e. it is the reference area;
- area A2, when a 2:1 ratio is shown, is equal to 50% of area A1 and all the other ratios shown in the Table 2 can be calculated on this basis.

As consequence of these area ratios there are different opening pressures whether proceeding from A → B or from B → A.

# CARTRIDGE VALVES

## 2/2 LOGIC ELEMENTS ACCORDING TO ISO 7368 (DIN 24342)

### ORDERING CODE

**KEL**

Logic element 2/2

**\*\***

**16** = NG16  
**25** = NG25

**\***

Function: see table 1

Areas ratio:

**U** = 1 : 1

**S** = 12.5 : 1

**B** = 2 : 1

(for version with drilled poppet see CF variant)

**F** = 2 : 1

**R** = 2 : 1

**\***

Opening pressure (bar)

(Tab.1 pressure values)

(Tab.2 spring's colour and code)

**\*\***

Calibrated orifices:

**00** = blind

**08** = 0.8 mm

**09** = 0.9 mm

**10** = 1.0 mm

**12** = 1.2 mm

**14** = 1.4 mm

**\*\***

**00** = No variant

**V1** = Viton

**CF** = With drilled poppet only for KEL\*\*B

**2**

Serial No.

**TAB. 1 - SYMBOL, FUNCTION, AREA RATIO AND OPENING PRESSURE**

Function	Symbol	Area ratio	Code	Opening pressure (bar)	
				A→B	B→A
Directional (U) (normally used for relief valve)		<b>A1 : A3</b> 1 : 1	KEL**UL00 KEL**UM00 KEL**UH00 KEL**UJ00	L = 0.3 M = 1.6 H = 4 J = 9	
Directional (U) with orifice		<b>A1 : A3</b> 1 : 1	KEL**UL** KEL**UM** KEL**UH**	L = 0.3 M = 1.6 H = 4	
Directional (S)		<b>A1 : A2</b> 12.5 : 1	KEL**SL00 KEL**SM00 KEL**SH00	L = 0.3 M = 0.6 H = 1.5	L = 4 M = 8 H = 20
Directional (S) with orifice		<b>A1 : A2</b> 12.5 : 1	KEL**SL** KEL**SM** KEL**SH**	L = 0.3 M = 0.6 H = 1.5	L = 4 M = 8 H = 20
Directional (B) (normally used for check valve)		<b>A1 : A2</b> 2 : 1	KEL**BL00 KEL**BM00 KEL**BH00	L = 0.5 M = 1 H = 2.5	L = 1 M = 2 H = 5
Flow control (F)		<b>A1 : A2</b> 2 : 1	KEL**FL** KEL**FM** KEL**FH**	L = 0.5 M = 1 H = 2.5	L = 1 M = 2 H = 5
With sensitized cover (R)		<b>A1 : A2</b> 2 : 1	KEL**RL00 KEL**RM00 KEL**RH00 KEL**RJ00	A → B	
				NG16	NG25
				L = 0.7 M = 1.5 H = 4	L = 0.6 M = 1.5 H = 3.5 J = 9

**TAB. 2 - SPRING'S COLOUR AND CODE**

Spring type	U		S		B-F		R	
	NG16	NG25	NG16	NG25	NG16	NG25	NG16	NG25
Cod. L	without colour	red	without colour	red	without colour	red	without colour	red
Cod. M	green	yellow	red	green	red	green	red	green
Cod. H	blue	blue	yellow	yellow	green	yellow	green	yellow
Cod. J	without colour							blue

**NG 16 PRESSURE DROP**

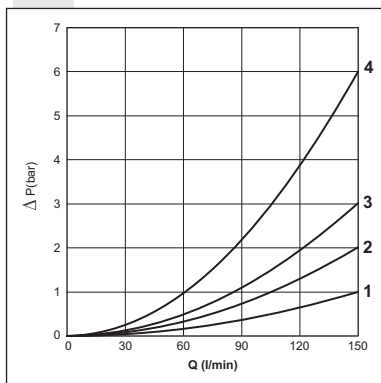

1 = KEL16U  
KEL16S  
2 = KEL16B  
3 = KEL16R  
4 = KEL16F

**NG25 PRESSURE DROP**

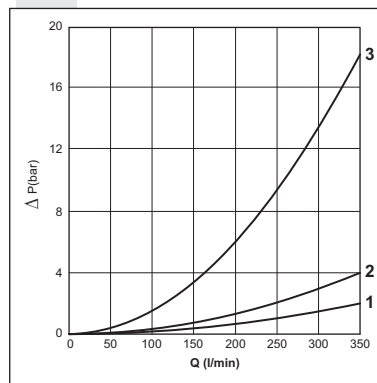

1 = KEL25U  
KEL25B  
KEL25R  
2 = KEL25S  
3 = KEL25F

The fluid used is a mineral oil with a viscosity of 46 mm<sup>2</sup>/s at 40°C. The tests were performed at a fluid temperature of 50°C.

OVERALL DIMENSIONS OF TWO-WAY VALVE SEAT ISO 7368/BA-06-2-A NG16 (DIN 24342)

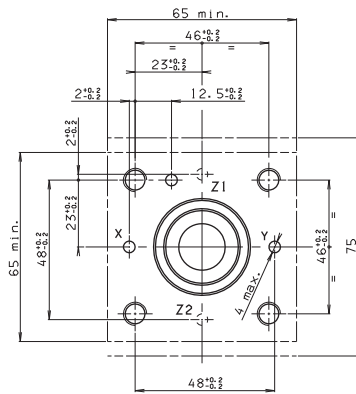
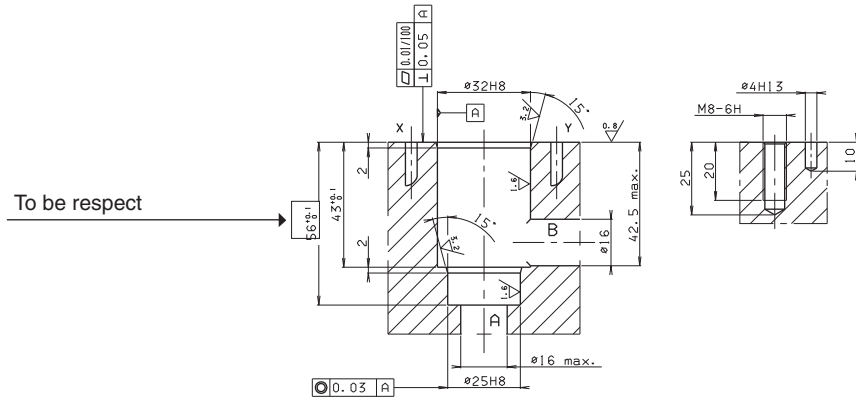

- X = piloting
- Y = draining
- Z = additional piloting
- Z1 = preferential piloting
- Z2 = preferential draining

OVERALL DIMENSIONS OF TWO-WAY VALVE SEAT ISO 7368/BB-08-2-A NG25 (DIN 24342)

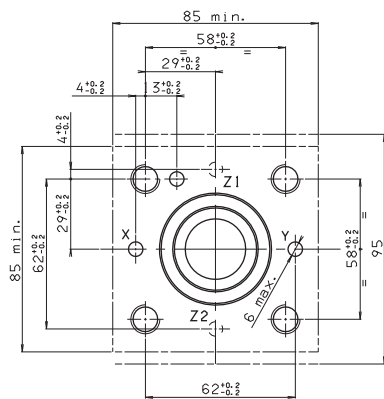
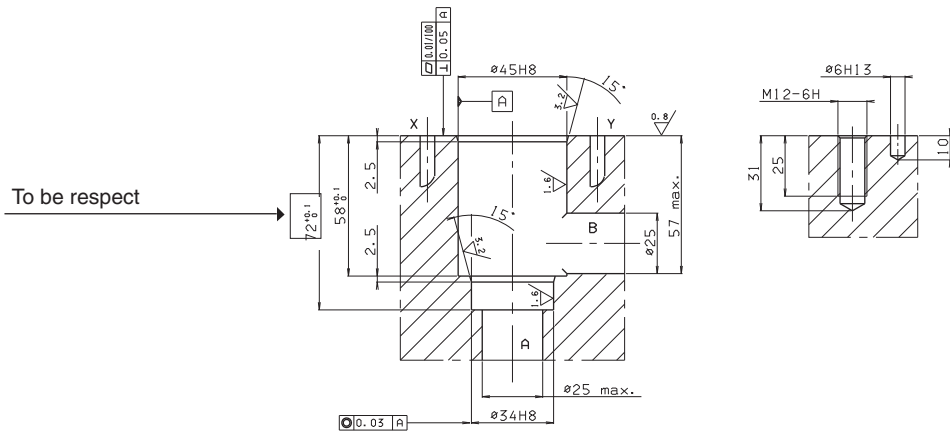

- X = piloting
- Y = draining
- Z = additional piloting
- Z1 = preferential piloting
- Z2 = preferential draining



# CARTRIDGE VALVES - COVERS

## COVERS ORDERING CODE

<b>KEC</b>	Covers for logic element 2/2
<b>**</b>	<b>16</b> = NG16 <b>25</b> = NG25
<b>**</b>	Type of cover (see Tab. 3) <b>RI</b> = Directional with external piloting <b>CQ</b> = Directional with stroke adjustment <b>RC</b> = Directional with interface NG6 <b>PC</b> = With hydraulic outlet pilot valve <b>SH</b> = With built-in-exchange (shuttle) <b>SP</b> = With built-in-exchange and interface NG6
<b>**</b>	<b>00</b> = No variant <b>V1</b> = Viton
<b>2</b>	Serial No.

**TAB. 1 - COVERS HYDRAULIC SYMBOLS**

Type	Symbol
<b>KEC**RI**2</b> Directional with external piloting	
<b>KEC**CQ**2</b> Directional with stroke adjustment	
<b>KEC**RC**2</b> Directional with interface NG6	
<b>KEC**PC**2</b> With hydraulic outlet pilot valve	
<b>KEC**SH**2</b> With built-in-exchange valve (shuttle)	
<b>KEC**SP**2</b> With built-in-exchange valve (shuttle) and interface NG6	

# CARTRIDGE VALVES - COVERS

## HYDRAULIC MOUNTING SCHEMES FOR KEC COVERS AND KEL LOGIC ELEMENTS

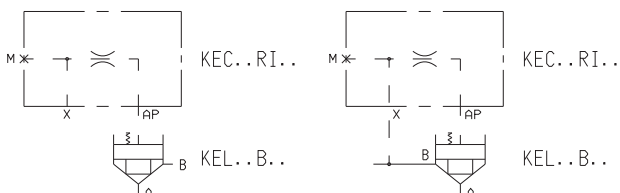
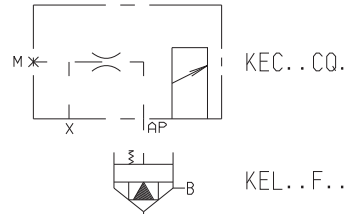
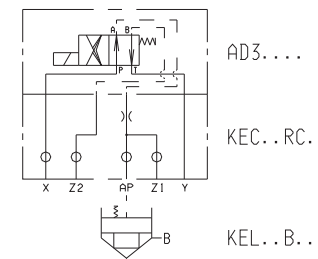
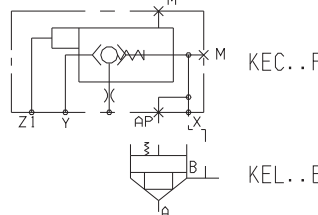
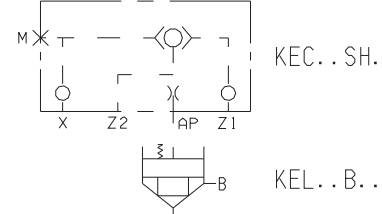
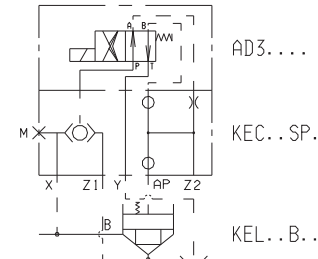
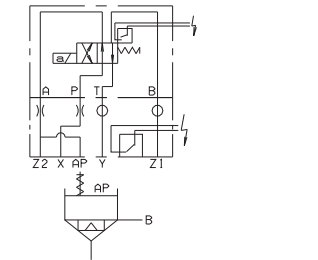
<p><b>KEC16/25RI...</b> <b>COVER WITH EXTERNAL PILOTING PORT</b></p> <p>A = External piloting X allows flow in both directions A → B and B → A. B = For rapid sequence safety circuit; A → B flow is allowed; when pressure reaches X valve closes. Only for CF variant (KEL.**:B... with drilled poppet), with no pressure in X it operates as a check valve between A and B.</p>	 <p>KEC..RI..    KEC..RI..</p> <p>KEL..B..    KEL..B..</p>
<p><b>KEC16/25CQ...</b> <b>COVER WITH STROKE LIMITATION</b></p> <p>Allows flow regulation in both directions A → B and B → A. By limiting the spool stroke the flow in both direction can be limited.</p>	 <p>KEC..CQ..    KEC..CQ..</p> <p>KEL..F..    KEL..F..</p>
<p><b>KEC16/25RC...</b> <b>COVER WITH INTERFACE NG6</b></p> <p>These covers have one mounting surface preset for a solenoid pilot valve. Proper connection of Y and Z2 to the A and/or B ports will allowing piloting of the valve opening and closing functions.</p>	 <p>AD3...    AD3...</p> <p>KEC..RC..    KEC..RC..</p> <p>KEL..B..    KEL..B..</p>
<p><b>KEC16/25PC...</b> <b>COVER WITH HYDRAULIC RELEASE PILOT VALVE</b></p> <p>This is a cover with external piloting to be connected to B port to obtain the standard unit function. Z1 pressure piloting allows flow transfer from B → A. Normally, in order to ensure the holding condition the main port B is connected to the load; piloting in Z1 should be at least 50% of the load pressure in B.</p>	 <p>KEC..PC..    KEC..PC..</p> <p>KEL..B..    KEL..B..</p>
<p><b>KEC16/25SH...</b> <b>COVER WITH INTEGRAL CHANGEOVER VALVE</b></p> <p>The logic element closes as function of the larger pressure in X and Z1, selected by the shuttle valve.</p>	 <p>KEC..SH..    KEC..SH..</p> <p>KEL..B..    KEL..B..</p>
<p><b>KEC16/25SP... COVER WITH INTEGRAL CHANGEOVER VALVE AND INTERFACE NG6</b></p> <p>The AP branch of the cartridge valve spring is connected with the pilot valve port. External piloting operates from Z2 → A of the pilot valve. An example is shown in the diagram of a type of connection used to keep the conical seat valve closed on both sides (interrupted flow both from A → B and from B → A).</p>	 <p>AD3...    AD3...</p> <p>KEC..SP..    KEC..SP..</p> <p>KEL..B..    KEL..B..</p>
<p><b>KRA16/25... COVER WITH ELECTRICAL CONTROL OF THE CLOSED POSITION AND INTERFACE NG6</b></p> <p>See cartridge type KRA... next pages</p>	

5

# CARTRIDGE VALVES - COVERS

## OVERALL DIMENSIONS KEC16RI... CHECK VALVE COVER

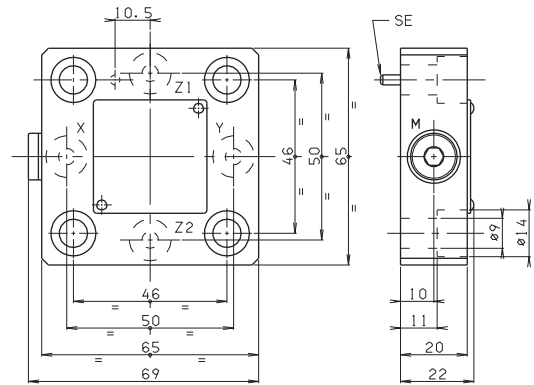
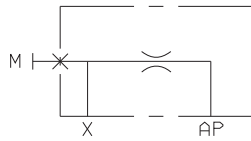

Weight: 0,5 Kg  
**M** = pressure gauge attachment  
 Orifice with calibrated  $\varnothing 1$  mm standard diameter  
 The covers are supplied with M8x25 UNI 5931  
 fixing screws, reference pin SE  $\varnothing 3 \times 12$  UNI 6873-71  
 Tightening torque 19÷24 Nm/1.9÷2.4 Kgm with 8.8 screws

## OVERALL DIMENSIONS KEC25RI... CHECK VALVE COVER

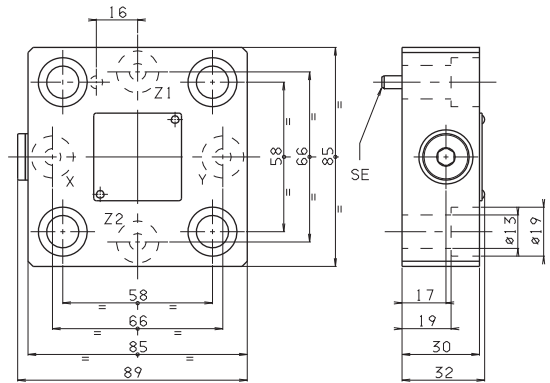
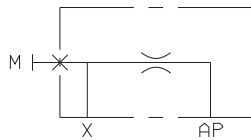

Weight: 1,3 Kg  
**M** = pressure gauge attachment  
 Orifice with calibrated  $\varnothing 1$  mm standard diameter  
 The covers are supplied with M12x35 UNI 5931  
 fixing screws, reference pin SE  $\varnothing 5 \times 12$  UNI 6873-71  
 Tightening torque 69÷80 Nm/6.9÷8 Kgm with 8.8 screws

## OVERALL DIMENSIONS KEC16CQ.. COVER WITH STROKE ADJUSTMENT

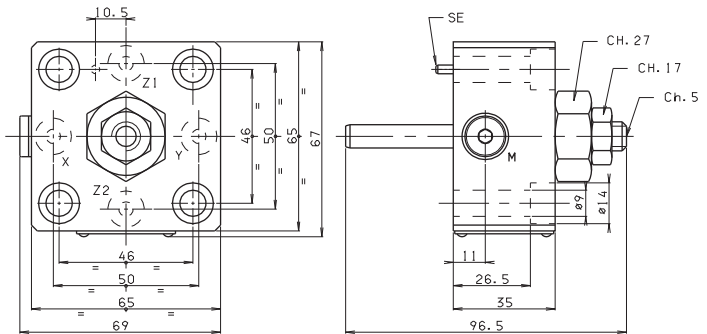
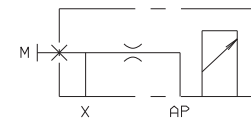

Weight: 0,9 Kg  
**M** = pressure gauge attachment  
 Orifice with calibrated  $\varnothing 1$  mm standard diameter  
 The covers are supplied with M8x40 UNI 5931  
 fixing screws, reference pin SE  $\varnothing 3 \times 12$  UNI 6873-71  
 Tightening torque 19÷24 Nm/1.9÷2.4 Kgm with 8.8 screws

## OVERALL DIMENSIONS KEC25CQ.. COVER WITH STROKE ADJUSTMENT

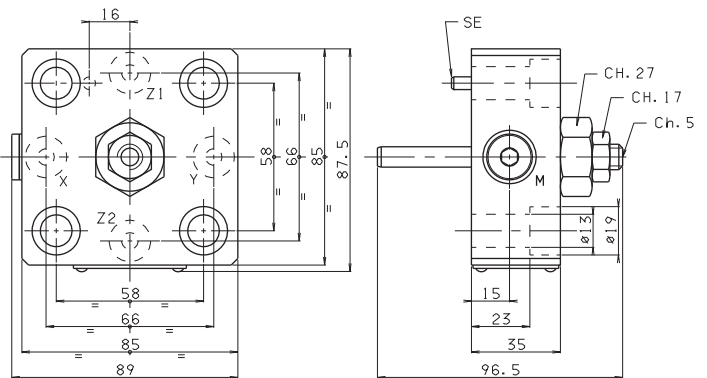
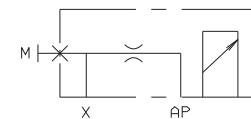

Weight: 1,6 Kg  
**M** = pressure gauge attachment  
 Orifice with calibrated  $\varnothing 1$  mm standard diameter  
 The covers are supplied with M12x40 UNI 5931  
 fixing screws, reference pin SE  $\varnothing 5 \times 12$  UNI 6873-71  
 Tightening torque 69÷80 Nm/6.9÷8 Kgm with 8.8 screws

# CARTRIDGE VALVES - COVERS

## OVERALL DIMENSIONS KEC16RC... COVER WITH INTERFACE CETOP 3/NG6



Weight: 1,2 Kg  
**M** = pressure gauge attachment  
 Orifice with calibrated  $\varnothing 1$  mm standard diameter  
 The covers are supplied with M8x40 UNI 5931 fixing screws, reference pin SE  $\varnothing 3 \times 12$  UNI 6873-71  
 tightening torque  $19 \div 24$  Nm/1.9  $\div$  2.4 Kgm with 8.8 screws

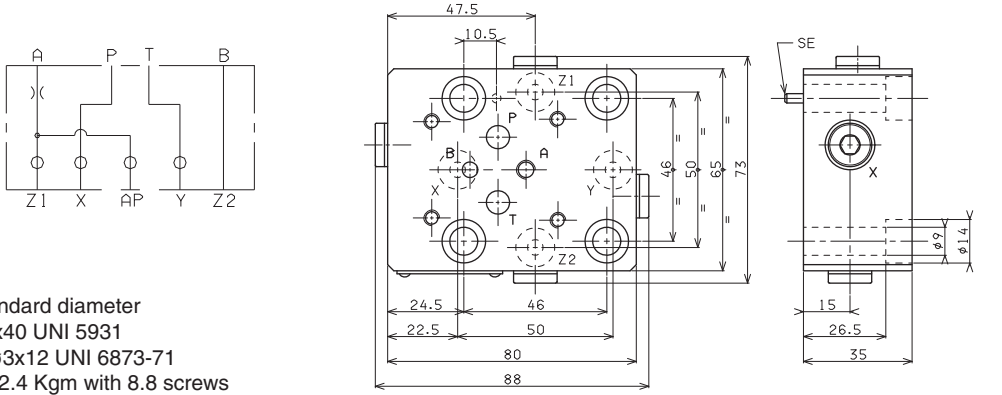

## OVERALL DIMENSIONS KEC25RC... COVER WITH INTERFACE CETOP 3/NG6



Weight: 1,8 Kg  
**M** = pressure gauge attachment  
 Orifice with calibrated  $\varnothing 1$  mm standard diameter  
 The covers are supplied with M12x45 UNI 5931 fixing screws, reference pin SE  $\varnothing 5 \times 12$  UNI 6873-71  
 tightening torque  $69 \div 80$  Nm/6.9  $\div$  8 Kgm with 8.8 screws

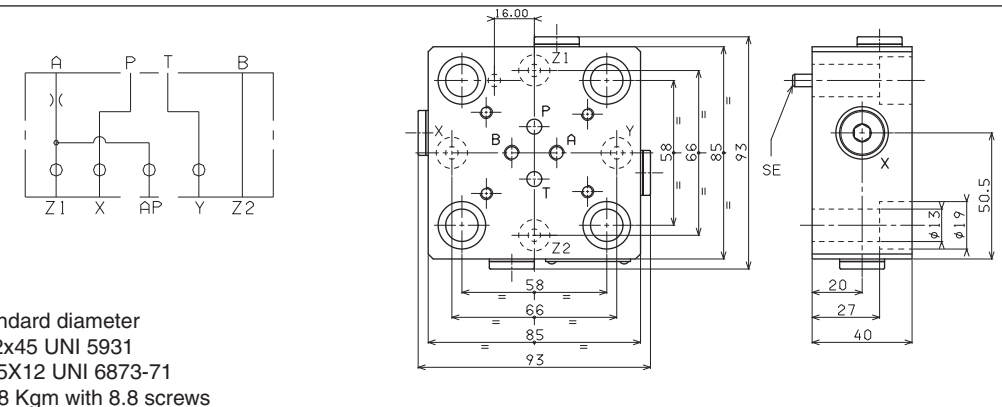

## OVERALL DIMENSIONS KEC16PC... COVER WITH HYDRAULIC OUTLET PILOT VALVE



Weight: 2,1 Kg  
**M** = pressure gauge attachment  
 Orifice with calibrated  $\varnothing 1$  mm standard diameter  
 The covers are supplied with M8x60 UNI 5931 fixing screws, reference pin SE  $\varnothing 3 \times 12$  UNI 6873-71  
 tightening torque  $19 \div 24$  Nm/1.9  $\div$  2.4 Kgm with 8.8 screws

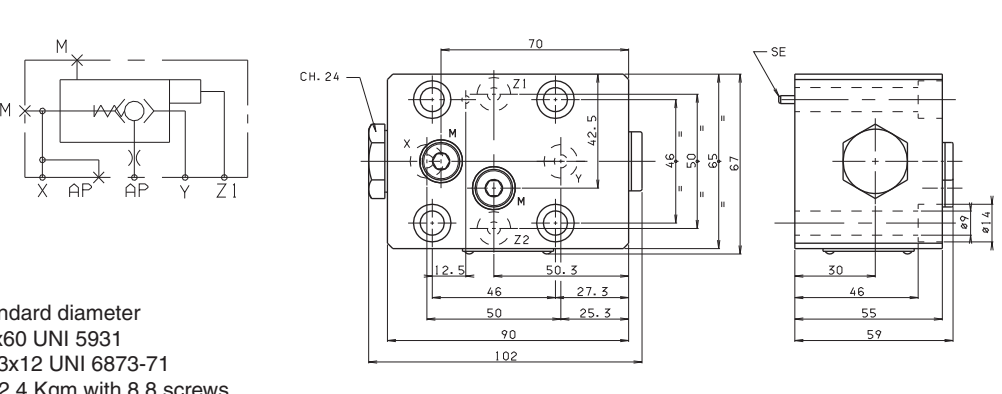

## OVERALL DIMENSIONS KEC25PC... COVER WITH HYDRAULIC OUTLET PILOT VALVE



Weight: 2,7 Kg  
**M** = pressure gauge attachment  
 Orifice with calibrated  $\varnothing 1$  mm standard diameter  
 The covers are supplied with M12x60 UNI 5931 fixing screws, reference pin SE  $\varnothing 5 \times 12$  UNI 6873-71  
 tightening torque  $69 \div 80$  Nm/6.9  $\div$  8 Kgm with 8.8 screws

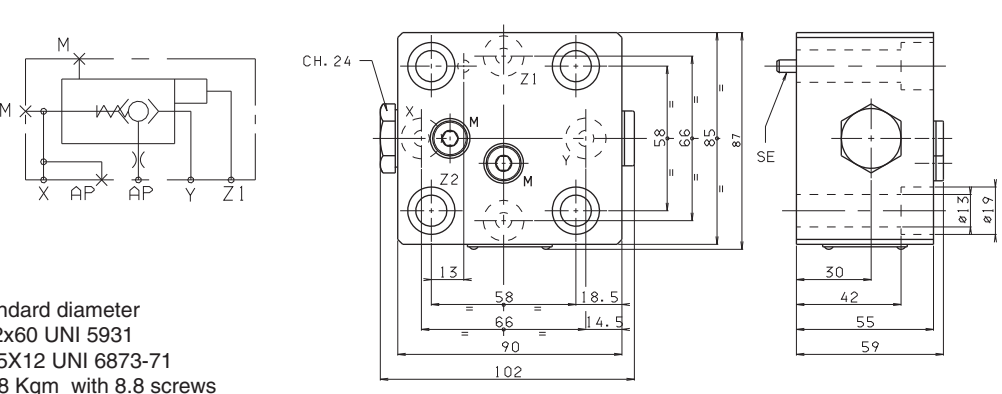

# CARTRIDGE VALVES - COVERS

## OVERALL DIMENSIONS KEC16SH... COVER WITH BUILT-IN EXCHANGE VALVE



Weight: 0,9 Kg  
**M** = pressure gauge attachment  
 Orifice with calibrated  $\varnothing 1$  mm standard diameter  
 The covers are supplied with M8x40 UNI 5931 fixing screws, reference pin SE  $\varnothing 3 \times 12$  UNI 6873-71 tightening torque  $19 \div 24$  Nm/1.9  $\div$  2.4 Kgm with 8.8 screws

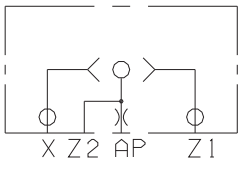

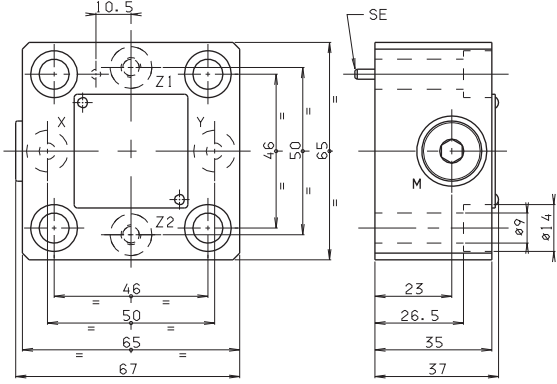

## OVERALL DIMENSIONS KEC25SH... COVER WITH BUILT-IN EXCHANGE VALVE



Weight: 1,5 Kg  
**M** = pressure gauge attachment  
 Orifice with calibrated  $\varnothing 1$  mm standard diameter  
 The covers are supplied with M12x40 UNI 5931 fixing screws, reference pin SE  $\varnothing 5 \times 12$  UNI 6873-71 tightening torque  $69 \div 80$  Nm/6.9  $\div$  8 Kgm with 8.8 screws

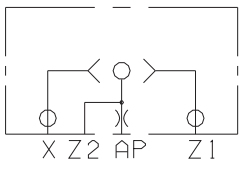

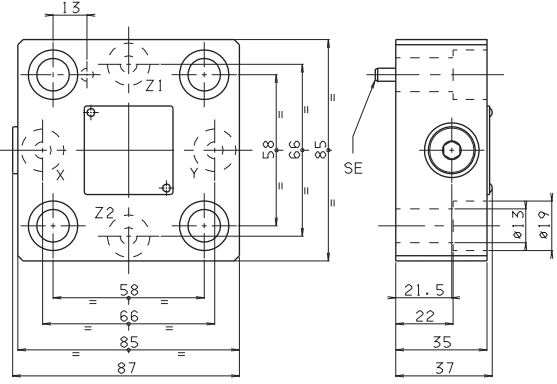

## OVERALL DIMENSIONS KEC16SP COVER WITH BUILT-IN EXCHANGE VALVE AND INTERFACE CETOP 3/NG6



Weight: 1,4 Kg  
**M** = pressure gauge attachment  
 Orifice with calibrated  $\varnothing 1$  mm standard diameter  
 The covers are supplied with M8x50 UNI 5931 fixing screws, reference pin SE  $\varnothing 3 \times 12$  UNI 6873-71 tightening torque  $19 \div 24$  Nm/1.9  $\div$  2.4 Kgm with 8.8 screws

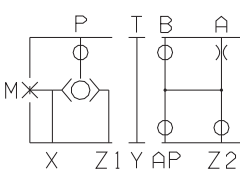

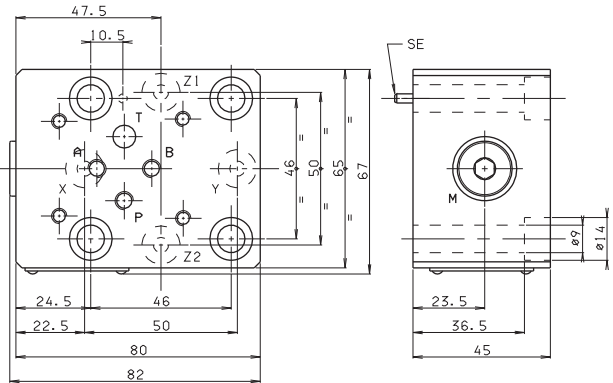

## OVERALL DIMENSIONS KEC25SP COVER WITH BUILT-IN EXCHANGE VALVE AND INTERFACE CETOP 3/NG6



Weight: 2 Kg  
**M** = pressure gauge attachment  
 Orifice with calibrated  $\varnothing 1$  mm standard diameter  
 The covers are supplied with M12x50 UNI 5931 fixing screws, reference pin SE  $\varnothing 5 \times 12$  UNI 6873-71 tightening torque  $69 \div 80$  Nm/6.9  $\div$  8 Kgm with 8.8 screws

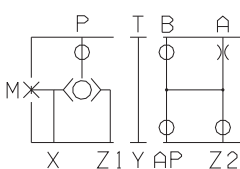

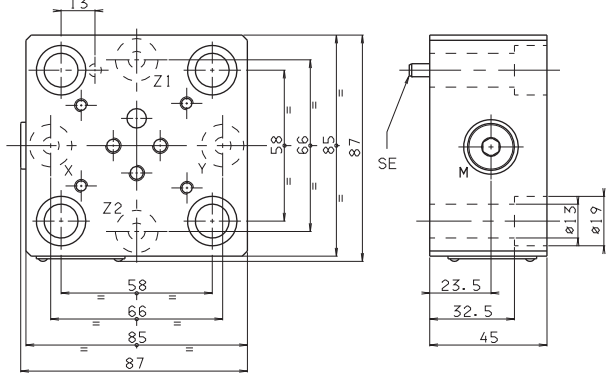

5



## MAXIMUM PRESSURE CARTRIDGE VALVES

Maximum pressure cartridge valves allow control of hydraulic circuit pressures up to 400 bar and 350 l/min maximum flow rate (NG25).

Besides the normal manual pressure regulation mode, function like

electrical command for discharge to drain, remote control, proportional pressure control or electrically selected dual pressure levels are also available.

Nominal size (max. diameter)	16mm / 25mm
Max. operating pressure	400 bar
Maximum nominal flow rate NG16	150 l/min
Maximum nominal flow rate NG25	350 l/min
Setting ranges	15 ÷ 400 bar

MAX. PRESSURE COVERS	
KEC16/25... WITH CMP	CAP. V • 11
C*P16/25...	CAP. V • 12
CETOP 3/NG06	CAP. I • 8
AD3E...	CAP. I • 11
AM3VM...	CAP. IV • 9
XP3...	CAP. VIII • 23

The cover interface allows the mounting of a CETOP 3/NG06 valve. A standard cartridge valve DIN 24342 is used. A cover not according to DIN rules is also available.

The valve response specification may be modified by selection of different internal orifices according to the required application. **The standard version has calibrated orifices of Ø 1 mm in X and AP.**

### DIN STANDARDS COVER ORDERING CODE

<b>KEC</b>	DIN standards cover
<b>**</b>	<b>16</b> = NG16 <b>25</b> = NG25
<b>**</b>	Type of cover <b>ME</b> = Max. pressure valve with interface CETOP 3 <b>MP</b> = Max. pressure valve <b>UE</b> = Exclusion valve with interface CETOP 3 <b>UN</b> = Exclusion valve <b>SL</b> = Sequencing valve
<b>*</b>	Setting ranges <b>1</b> = 15 ÷ 45 bar ( <b>white spring</b> ) <b>2</b> = 15 ÷ 145 bar ( <b>yellow spring</b> ) <b>3</b> = 60 ÷ 400 bar ( <b>green spring</b> )
<b>*</b>	Type of adjustment <b>M</b> = Plastic knob <b>C</b> = Grub screw
<b>**</b>	<b>00</b> = No variant <b>V1</b> = Viton
<b>3</b>	Serial No.

### PLATE MOUNTING COVERS ORDERING CODE

<b>C*P</b>	<b>M</b> = Cover with max. pressure valve <b>U</b> = Cover with exclusion valve <b>S</b> = Cover with sequencing valve
<b>*</b>	<b>E</b> = Presetting for solenoid valve (Omit if not required)
<b>**</b>	<b>16</b> = NG16 <b>25</b> = NG25
<b>*</b>	Type of adjustment <b>M</b> = Plastic knob <b>C</b> = Grub screw
<b>*</b>	Setting ranges <b>1</b> = 15 ÷ 45 bar ( <b>white spring</b> ) <b>2</b> = 15 ÷ 145 bar ( <b>yellow spring</b> ) <b>3</b> = 60 ÷ 400 bar ( <b>green spring</b> )
<b>**</b>	<b>00</b> = No variant <b>V1</b> = Viton
<b>2</b>	Serial No.

### MANUAL PRESSURE REGULATION

This regulation facility is incorporated in the cartridge closing cover. A Z1 port is provided on the cover for remote piloting via directional or pressure control valves.

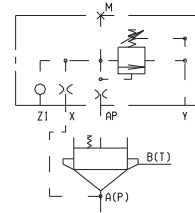

KEC. \*\*. MP. .  
CMP. \*\*. .

KEL. \*\*. U. .

### MANUAL PRESSURE REGULATION AND ELECTRICAL COMMAND FOR DISCHARGE TO DRAIN

This arrangement uses an electrically controlled valve type AD3E15.. which normally, in the de-energized position, allows discharge to drain of the controlled flow. When energized, the system operates at the pressure set on the piloting unit incorporated in the closing cover.

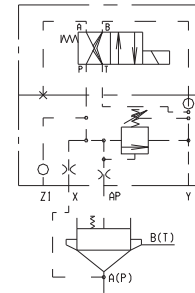

AD. 3. E.

KEC. \*\*. ME. .  
CMP. E. \*\*. .

KEL. \*\*. U. .

### MANUAL REGULATION AND PROPORTIONAL CONTROL OF THE PRESSURE

This arrangement uses a proportional pressure valve type XP3.. as the pilot, which allows proportional regulation of the controlled system pressure as a function of an electrical command signal.

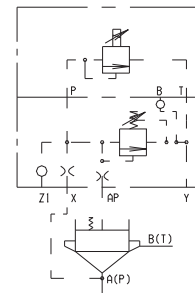

XP. 3. .

KEC. \*\*. ME. .  
CMP. E. \*\*. .

KEL. \*\*. U. .

### MANUALLY ADJUSTABLE AND ELECTRICALLY SELECTED TWO LEVEL PRESSURE UNIT

This arrangement uses a dual solenoid electrically controlled valve type AD3E02C.. and a modular maximum pressure valve type AM3VMA... which, when combined, allow implementation of an electrically selected two level pressure system.

Normally, with the solenoid valve de-energized, the controlled flow is discharged to drain.

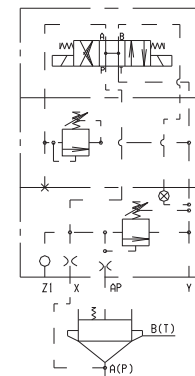

AD. 3. E.

AM. 3. VM. . .

KEC. \*\*. ME. .  
CMP. E. \*\*. .

KEL. \*\*. U. .

# CARTRIDGE VALVES - COVERS

## KEC16MP/UN/SL... WITH MAX. PRESSURE VALVE / EXCLUSION / SEQUENCING - IN LINE MOUNTING



**DIN STANDARD**

Weight: 1,3 Kg  
The covers are supplied with M8x35 UNI 5931 fixing screws and reference pins dia  $\varnothing 3 \times 12$  UNI 6874-71

KEC16MP...

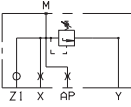

KEC16UN...

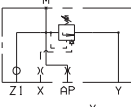

KEC16SL...

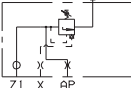

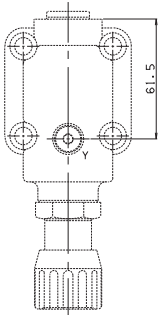

61.5

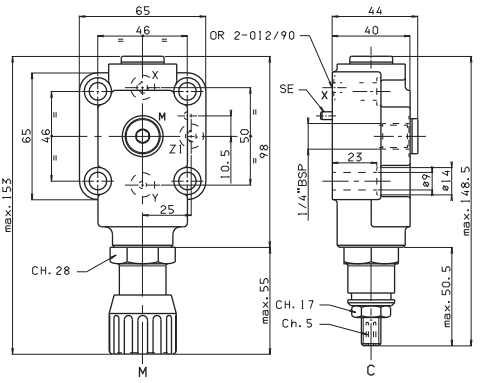

max. 153

max. 55

max. 148.5

max. 50.5

CH. 28

CH. 17

Ch. 5

M

C

## KEC25MP/UN/SL... WITH MAX. PRESSURE / EXCLUSION / SEQUENCING - IN LINE MOUNTING



**DIN STANDARD**

Weight: 1,8 Kg  
The covers are supplied with M12x45 UNI 5931 and reference pins dia  $\varnothing 5 \times 12$  UNI 6874-71

KEC25MP...

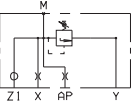

KEC25UN...

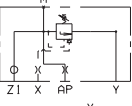

KEC25SL...

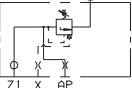

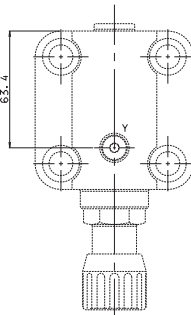

63.4

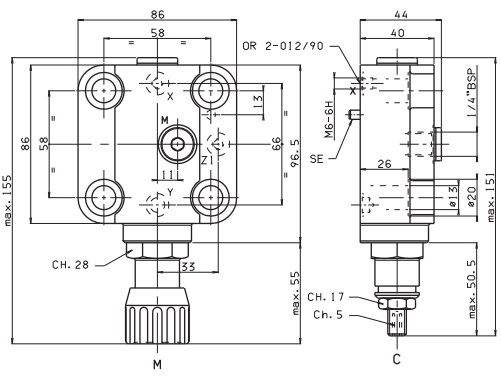

max. 155

max. 55

max. 151

max. 50.5

CH. 28

CH. 17

Ch. 5

M

C

## KEC16ME/UE WITH MAX. PRESSURE VALVE / EXCLUSION WITH INTERFACE CETOP 3 - IN LINE MOUNTING



**DIN STANDARD**

Weight: 1,3 Kg  
The covers are supplied with M8x35 UNI 5931 fixing screws and reference pins dia  $\varnothing 3 \times 12$  UNI 6874-71

KEC16ME...

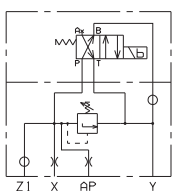

KEC16UE...

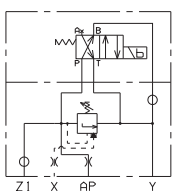

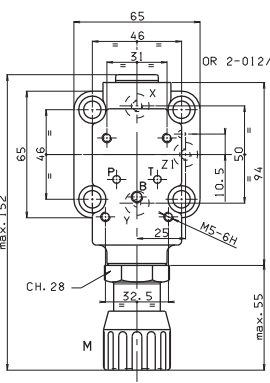

max. 152

max. 55

max. 148.5

max. 50.5

CH. 28

CH. 17

Ch. 5

M

C

## KEC25ME/UE WITH MAX. PRESSURE VALVE / EXCLUSION WITH INTERFACE CETOP 3 - IN LINE MOUNTING



**DIN STANDARD**

Weight: 1,8 Kg  
The covers are supplied with M12x45 UNI 5931 fixing screws and reference pins dia  $\varnothing 5 \times 12$  UNI 6874-71

KEC25ME...

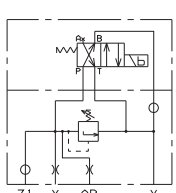

KEC25UE...

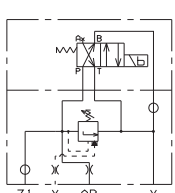

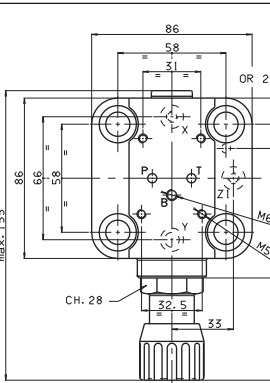

max. 155

max. 55

max. 151

max. 50.5

CH. 28

CH. 17

Ch. 5

M

C

5

VALV/KEC003\_E/01-2000

V • 11

  
 Motion Systems

# CARTRIDGE VALVES - COVERS

## C\*P16... WITH MAX. PRESSURE VALVE / EXCLUSION / SEQUENCING - PLATE MOUNTING

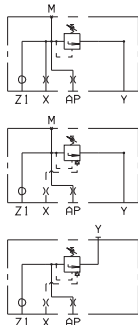

CMP16...

CUP16...

CSP16...

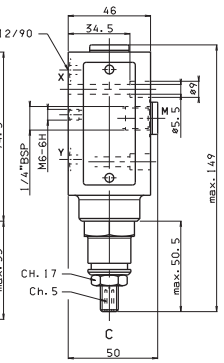
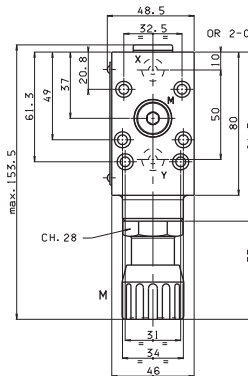
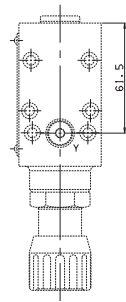

Weight: 1,3 Kg  
The covers are supplied with  
M5x45 UNI 5931 fixing screws

## C\*P25... WITH MAX. PRESSURE VALVE / EXCLUSION / SEQUENCING - PLATE MOUNTING

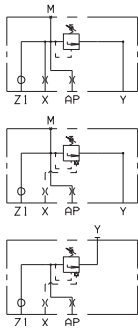

CMP25...

CUP25...

CSP25...

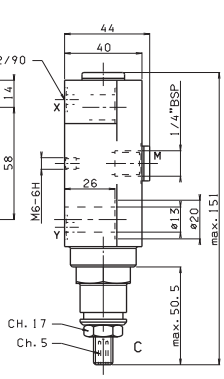
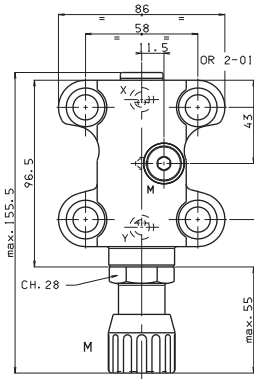
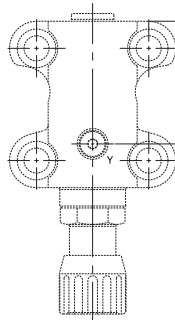

Weight: 1,5 Kg  
The covers are supplied with  
M12x45 UNI 5931 fixing screws

## C\*PE16 WITH MAX. PRESSURE VALVE / EXCLUSION WITH INTERFACE CETOP 3 - PLATE MOUNTING

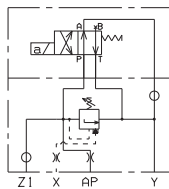
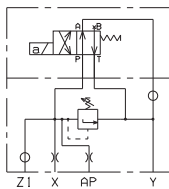

CMPE16...

CUPE16...

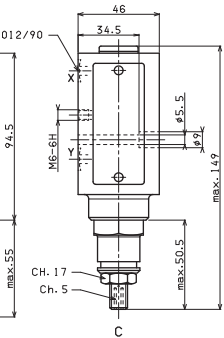
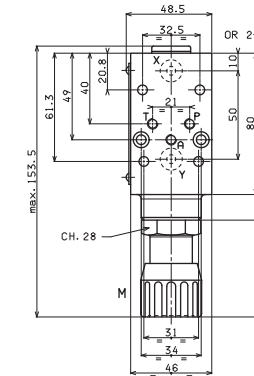

Weight: 1,3 Kg  
The covers are supplied with  
M5X45 UNI 5931 fixing screws

## C\*PE25 WITH MAX. PRESSURE VALVE / EXCLUSION WITH INTERFACE CETOP 3 - PLATE MOUNTING

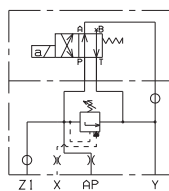
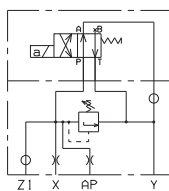

CMPE25...

CUPE25...

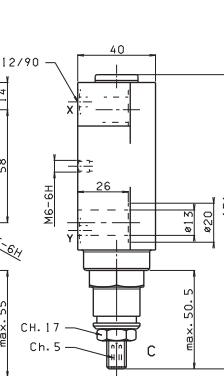
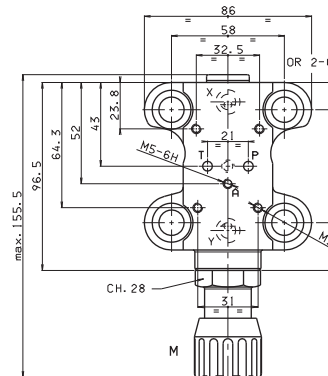

Weight: 1,5 Kg  
The covers are supplied with  
M12x45 UNI 5931 fixing screws



## KRA16/25... CARTRIDGE VALVES WITH ELECTRICAL POSITION CONTROL



This valve series is used in those applications where monitoring of the "actual" valve position is required for managing machine safety cycles as required by current accident prevention legislation. Typical examples of applications where this product is used include: hydraulic presses in general, plastic component injection and blow-form presses, die-casting presses.

The valve is composed of a closure cover where the inductive position monitoring proximity sensor is inserted to signal the two possible states of logic element manufactured to DIN 24342 standard.

This valve, in view of its being placed inside a safety system loop, can detect movement dangerous both for the safety of the operator and of the machine itself.

Availability of the CETOP 3 mounting interface on closure cover allows direct insertion of the piloting valves into the main valve, offering in this way to the designer the possibility to produce compact systems which can be easily mounted inside the machine.

### KRA16/25...

OVERALL DIMENSIONS	CAP. V • 14
KRA16/25... + AD3V...	CAP. V • 15
PROXIMITY FOR KRA	CAP. V • 16
AD3V...	CAP. I • 14
"D15" DC COILS	CAP. I • 19
L.V.D.T. FOR AD3V	CAP. I • 22
STANDARD CONNECTORS	CAP. I • 20

### ORDERING CODE

**KRA**

Cartridge valve with electrical position control (logic element 2/2 incorporated)

\*\*

16 = NG16  
25 = NG25

\*

Calibrated orifices at ports A and P:

0 = no orifice  
1 = Ø 1 mm dia opening (NG16 in standard configuration)  
2 = Ø 1.2 mm dia opening (NG25 in standard configuration)

\*

Opening pressure (bar):

NG16	NG25
H = 4 (green spring)	3.5 (yellow spring)
J = 12 (no colour spring)	9 (blue spring)

00

No variant

1

Serial No.

### HYDRAULIC SYMBOL

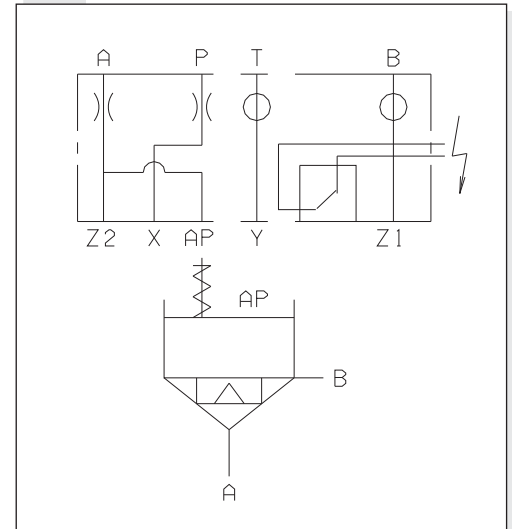

5

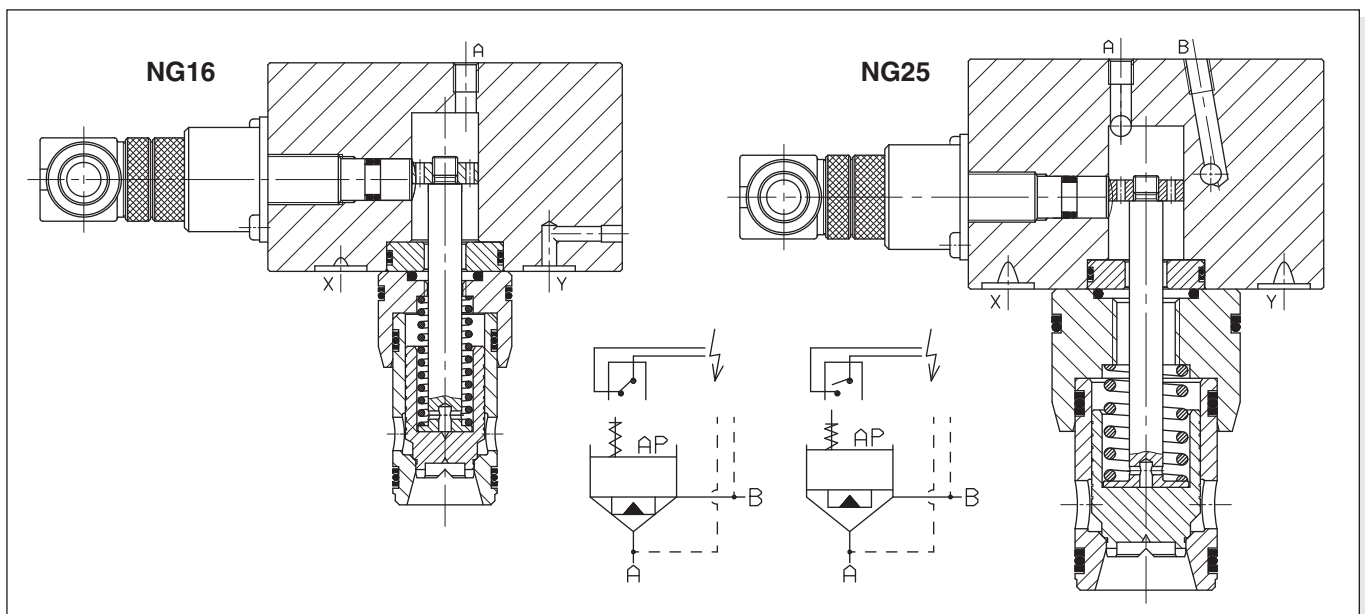

# KRA... CARTRIDGE VALVES WITH ELECTRICAL POSITION CONTROL

## OVERALL DIMENSIONS KRA.16...

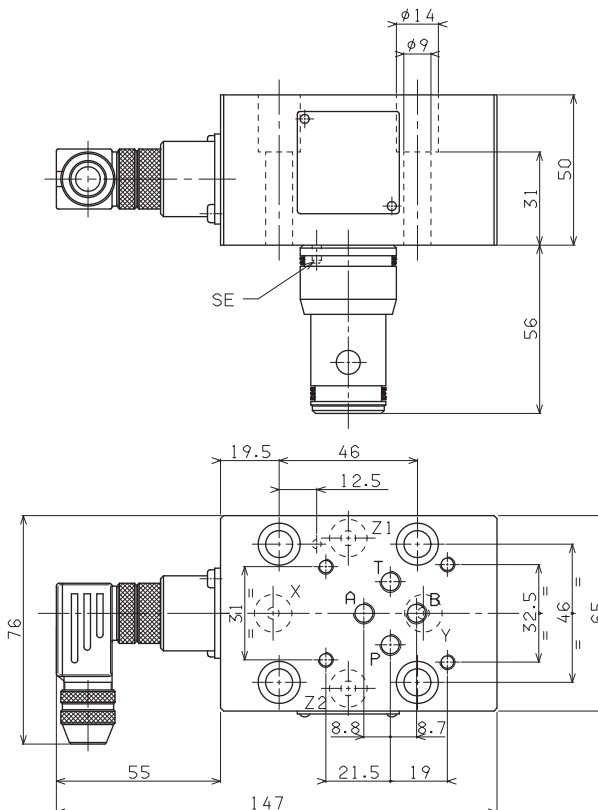

These covers are supplied complete with dowels and calibrated orifices on inputs A (AP) and P ( X); mounting screws can be supplied on request.

5

- Fixing screws T.C.E.I. M8X45 UNI 5931
- Reference pin dia  $\varnothing$  3X12 UNI 6873
- Screws S.T.E.I. M6X1X6 UNI 5923 dia  $\varnothing$  1mm
- Weight 2,2 Kg

## OVERALL DIMENSIONS KRA.25...

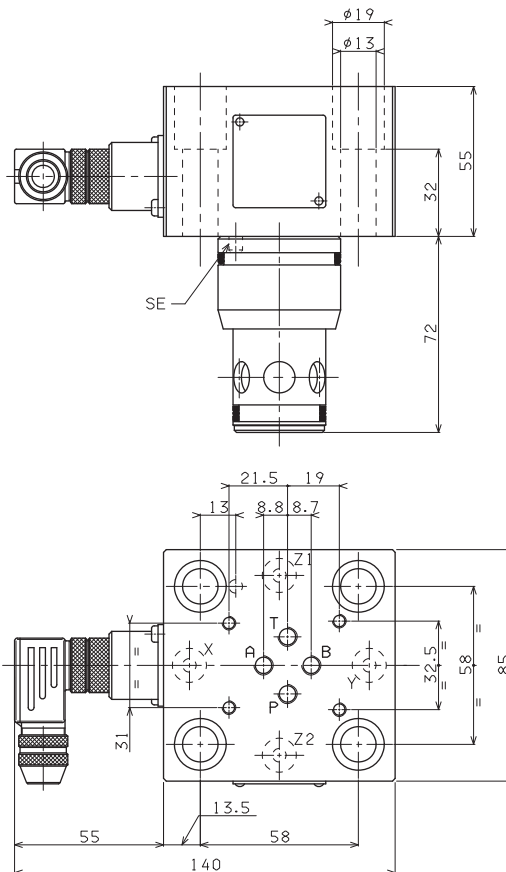

These covers are supplied complete with dowels and calibrated orifices on inputs A (AP) and P ( X); mounting screws can be supplied on request.

- Fixing screws T.C.E.I. M12X50 UNI 5931
- Reference pin dia  $\varnothing$  5X12 UNI 6873
- Screws S.T.E.I. M6X1X6 UNI 5923 dia  $\varnothing$  1.2mm
- Weight 3,42 Kg

## KRA16/25... + AD3V... CARTRIDGE VALVES WITH ELECTRICAL POSITION CONTROL VALVE



### KRA16/25... + AD3V...

PROXIMITY FOR KRA	CAP. V • 16
AD3V...	CAP. V • 14
D15 DC COIL	CAP. I • 19
L.V.D.T. FOR AD3V	CAP. I • 22
STANDARD CONNECTORS	CAP. I • 20

This valve series is used in those applications where monitoring of the "actual" valve position is required for managing machine safety cycle as required by current accident prevention legislation.

Typical example of application where this product is used include: hydraulic presses in general, plastic components injection and blow-form presses, die-casting presses. The valve is composed of closure cover where the inductive position monitoring proximity sensor is inserted to signal the two possible states of logic element manufactured to DIN 24342 standard.

This valve, in view of its being placed inside a safety system loop, can detect movements dangerous both for the safety of the operator and of the machine itself. Use a single solenoid directional valve AD.3.V... as piloting unit allows increase in the safety system control level, since even the piloting unit is equipped with a position monitoring proximity sensor capable of signalling the two possible valve states.

### HYDRAULIC SYMBOL

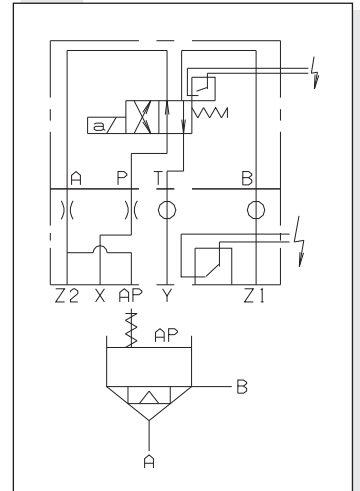

By combining these two monitoring systems it becomes possible to evaluate the hydraulic system response speed to prevent any possible malfunctioning or dangerous situations

These covers are supplied complete with dowel and calibrated orifices on inputs A (AP) /P ( X); mounting screws can be supplied on request

5

### KRA16... + AD3V...

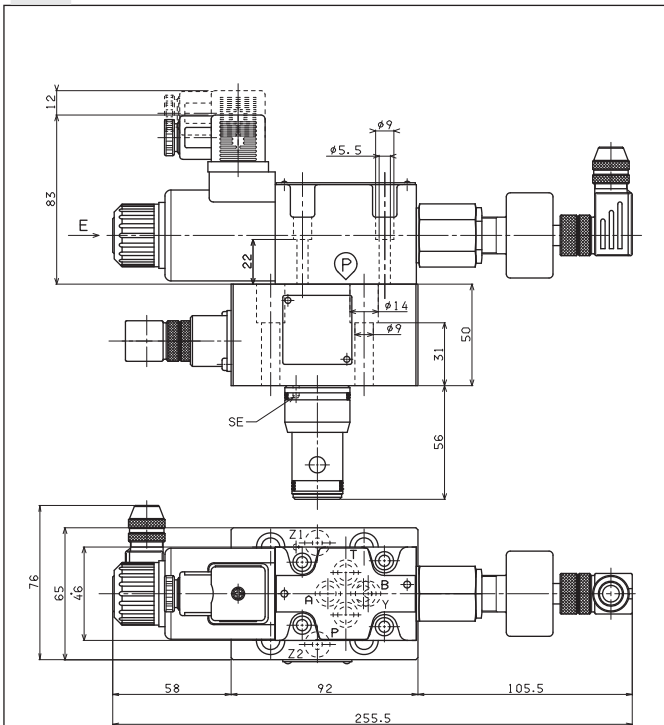

Fixing screws T.C.E.I. M8X45 UNI 5931

Reference pin dia Ø 3X12 UNI 6873

Screw S.T.E.I. M6X1X6 UNI 5923 dia Ø 1mm

### KRA25... + AD3V...

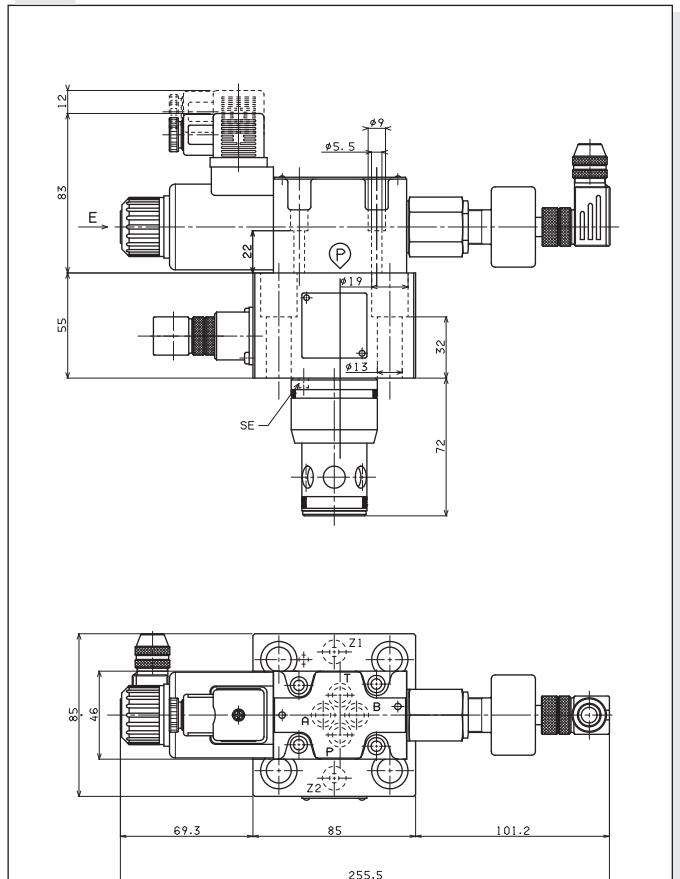

Fixing screws T.C.E.I. M12X50 UNI 5931

Reference pin dia Ø5X12 UNI 6873

Screw S.T.E.I. M6X1X6 UNI 5923 dia Ø 1.2mm

# TECHNICAL SPECIFICATIONS PROXIMITY SENSORS AND CONNECTORS



The inductive proximity sensors make it possible to detect metal objects; the operating principle is based on a high frequency oscillator which produces an electromagnetic field in the immediate vicinity of the sensor.

The presence of a metal object (activator) inside the field dampens the amplitude of the oscillation because part of electromagnetic energy is transferred from the sensor to the activator and from there it is dissipated through the effect of the induced currents.

In addition to the shape and the dimensions of the sensor, its sensitivity also depends on the type of metal from which the activator is made.

## SPECIFICATIONS

Max. pressure	500 bar
External diameter	M12x1
Release distance	0 ÷ 1.1 mm
Outlet function	PNP - NA
Stabilized supply	10 ÷ 30 VDC
Release hysteresis	≤ 0.2 mm
Type of mounting	wire
Max. current supplied	130 mA
Residual undulation	≤ 15%
Max switching frequency	1000 Hz
Casing material	stainless steel
Type of attachment	connector
Degree of protection	IP68 on active surface
Ambient temperature	-25°C ÷ 70°C
Protection against short circuit	yes

## CONNECTION WIRING DIAGRAM

Outlet PNP-NA  
 1 = brown (positive)  
 3 = blue (negative)  
 4 = black (positive signal)

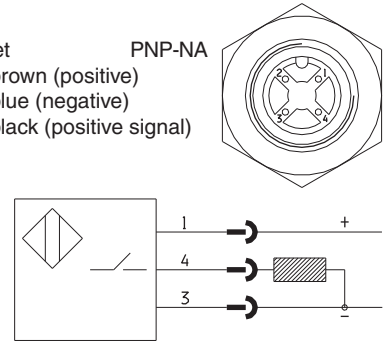

5

## HOUSING AND SENSOR OVERALL DIMENSIONS

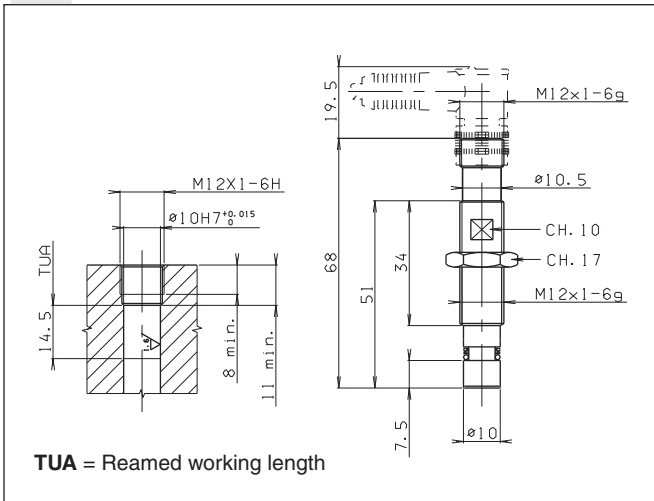

## OVERALL DIMENSIONS CONNECTOR

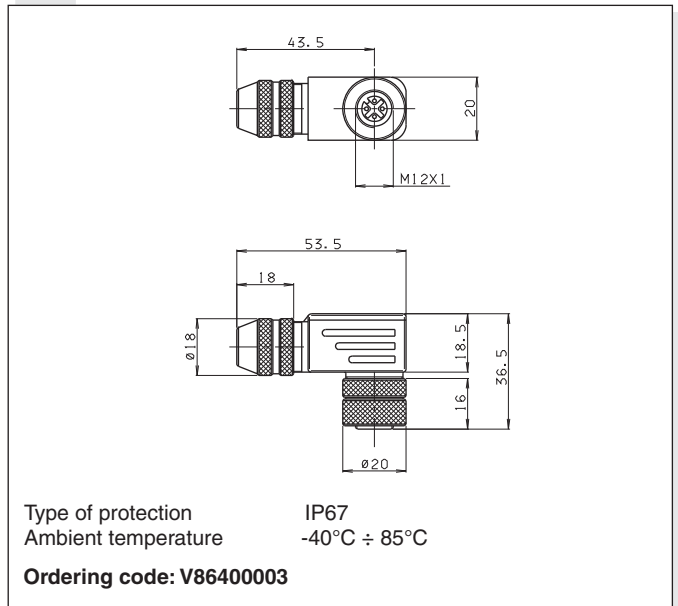

## ABBREVIATIONS

AP	HIGH PRESSURE CONNECTION
AS	PHASE LAG (DEGREES)
BP	LOW PRESSURE CONNECTION
C	STROKE (MM)
CH	ACROSS FLATS
Ch	INTERNAL ACROSS FLATS
DA	AMPLITUDE DECAY (dB)
DP	DIFFERENTIAL PRESSURE (BAR)
F	FORCE (N)
I%	INPUT CURRENT (A)
M	MANOMETER CONNECTION
NG	KNOB TURNS
OR	SEAL RING
P	LOAD PRESSURE (BAR)
PARBAK	PARBAK RING
PL	PARALLEL CONNECTION
Pr	REDUCED PRESSURE (BAR)
Q	FLOW (L/MIN)
QP	PUMP FLOW (L/MIN)
SE	ELASTIC PIN
SF	BALL
SR	SERIES CONNECTION
X	PILOTING
Y	DRAINAGE

## IN LINE VALVES CARTRIDGE VALVES

SEE CATALOGUE  
CODE **DOC00044**



# SUBPLATES

## ABBREVIATIONS

AP	HIGH PRESSURE CONNECTION
AS	PHASE LAG (DEGREES)
BP	LOW PRESSURE CONNECTION
C	STROKE (MM)
CH	ACROSS FLATS
Ch	INTERNAL ACROSS FLATS
DA	AMPLITUDE DECAY (dB)
Dp	DIFFERENTIAL PRESSURE (BAR)
F	FORCE (N)
I%	INPUT CURRENT (A)
M	MANOMETER CONNECTION
NG	KNOB TURNS
OR	SEAL RING
P	LOAD PRESSURE (BAR)
PARBAK	PARBAK RING
PL	PARALLEL CONNECTION
Pr	REDUCED PRESSURE (BAR)
Q	FLOW (L/MIN)
Qp	PUMP FLOW (L/MIN)
SE	ELASTIC PIN
SF	BALL
SR	SERIES CONNECTION
X	PILOTING
Y	DRAINAGE

## CAST IRON (\*) AND ALUMINIUM (\*) SUBPLATES

### SUBPLATES CETOP 2



BS2...	CAP. VII • 2
BC2...	CAP. VII • 4
BM2...	CAP. VII • 5

### SUBPLATES CETOP 5



BS5...	CAP. VII • 19
BC5...	CAP. VII • 24
BM5...	CAP. VII • 28

### SUBPLATES CETOP 3



BS3...	CAP. VII • 7
BS3W..	CAP. VII • 9
BC3...	CAP. VII • 10
BC* FOR XQ*3	CAP. VII • 13
BC06...	CAP. VII • 14
BM3...	CAP. VII • 16

### CMP10 CARTRIDGE VALVE



CMP10	CAP. VII • 30
-------	---------------

For other cartridge valve, see catalogue code DOC00044

\* Cast iron subplates, recommended pressure max. 320 bar  
Aluminium subplates, recommended pressure max. 230 bar



## BS2... SINGLE STATION SUBPLATE

### BS2.\*\*...

- BS** Single subplate (blanking)
- 2** CETOP 2/NG4
- \*\*** 02 / 03 / 04 / 05 / 07
- 00** No variant
- 1** Serial No.

Weight: 0,09 Kg  
 Fixing screws  
 M5x25 UNI 5931

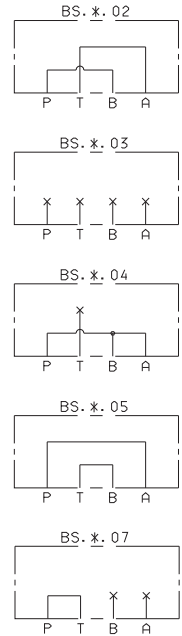
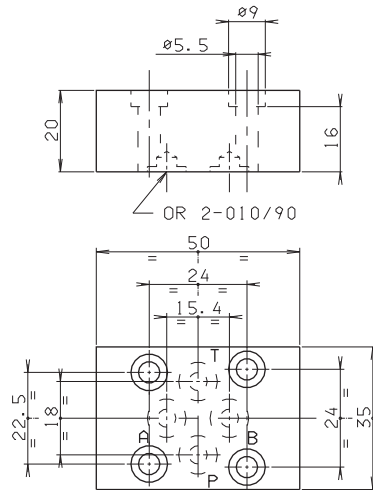

### CETOP 2 SUBPLATES

BS2**... / BS212...	
BS214...	CAP. VII • 2
BS216... / BS220...	
BS32...	CAP. VII • 3
BC250AB... / BC250PT...	
BC251...	CAP. VII • 4
BM2**... / BM260...	
	CAP. VII • 5
BM250... / BM270...	
	CAP. VII • 6
CMP02...	CARTRIDGE CATALOGUE

### BS212 (WITH REAR CONNECTION TO 1/4" BSP)

- BS** Single subplate
- 2** CETOP 2/NG4
- 12** 1/4" BSP rear connectors
- 00** No variant
- 1** Serial No.

Weight: 0,3 Kg  
 Fixing screws M5x35 UNI 5931

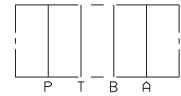
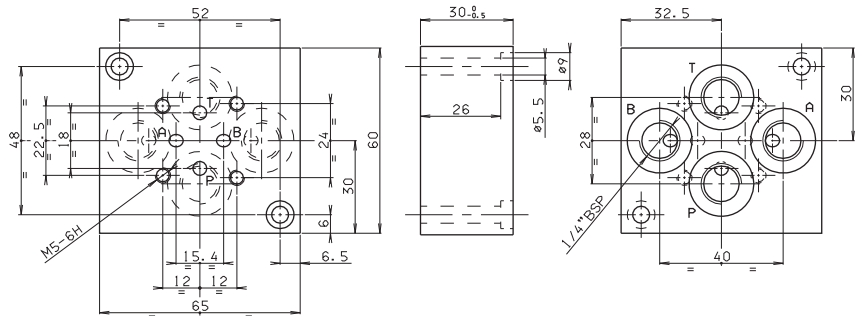

### BS214 (WITH SIDE CONNECTION TO 1/4" BSP)

- BS** Single subplate
- 2** CETOP 2/NG4
- 14** 1/4" BSP side connectors
- 00** No variant
- 1** Serial No.

Weight: 0,3 Kg  
 Fixing screws M5x35 UNI 5931

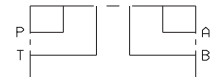
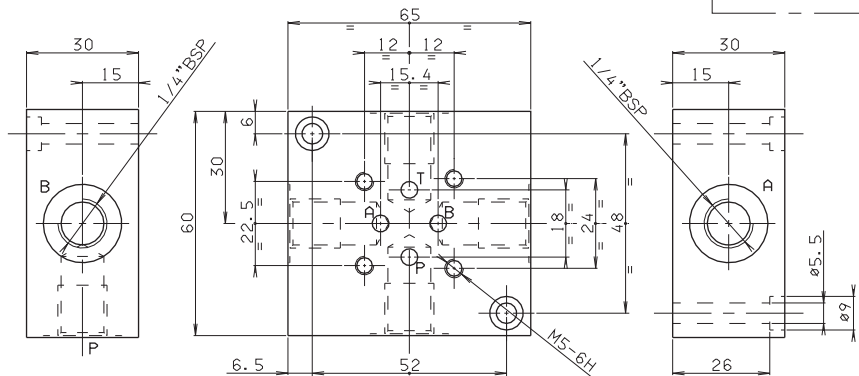



# BS2... SINGLE STATION SUBPLATE

## BS216 (WITH CONNECTORS P/T REAR, A/B SIDE TO 1/4" BSP)

- BS** Single subplate
- 2** CETOP 2/NG4
- 16** 1/4" BSP rear and side connectors
- 00** No variant
- 1** Serial No.

Weight: 0,3 Kg  
 Fixing screws M5x35 UNI 5931

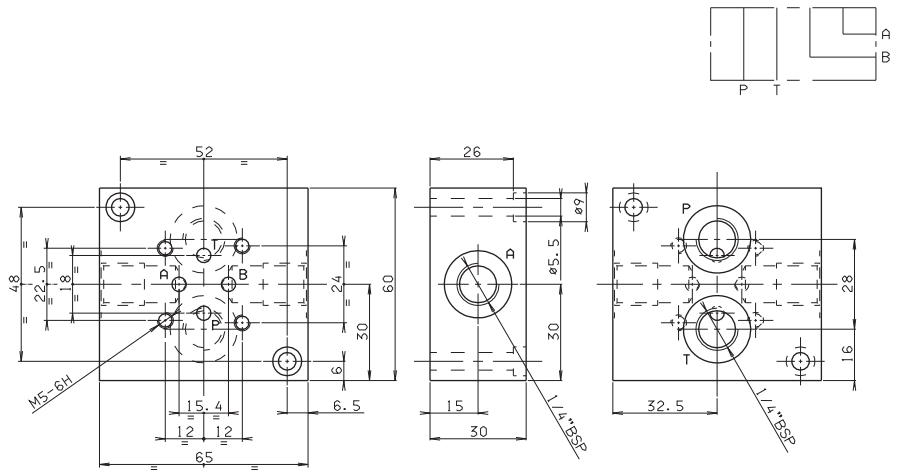

## BS220 (WITH CONNECTORS P/T REAR, A/B SIDE TO 1/4" BSP)

- BS** Single subplate
- 2** CETOP 2/NG4
- 20** 1/4" BSP rear and side connectors
- C** Type of adjustment grub screws
- \*** Setting ranges
  - 1 = max. 30 bar (white spring)
  - 2 = max. 90 bar (yellow spring)
  - 3 = max. 180 bar (green spring)
  - 4 = max. 250 bar (orange spring)
- \*\*** 00 = No variant  
V1 = Viton
- 1** Serial No.

Weight: 0,45 Kg  
 Fixing screws M5x50 UNI 5931

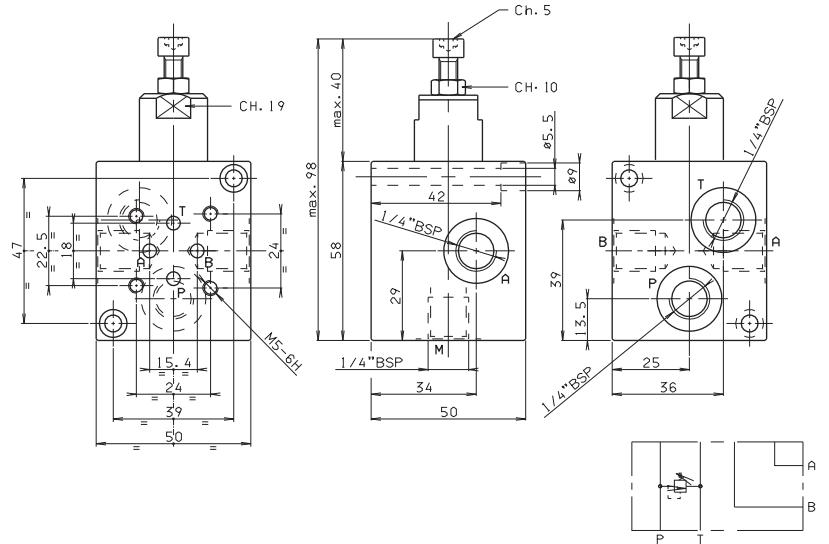

• The minimum permissible setting pressure depending on the spring:  
 see cartridge valve type CMP.02...

## BS32 (REDUCTION PLATE FROM CETOP 3/NG6 TO CETOP 2/NG4)

- BS** Single subplate
- 3** CETOP 3/NG6
- 2** CETOP 2/NG4
- 00** No variant
- 1** Serial No.

Weight: 0,12 Kg  
 Fixing screws M5x20 UNI 5931

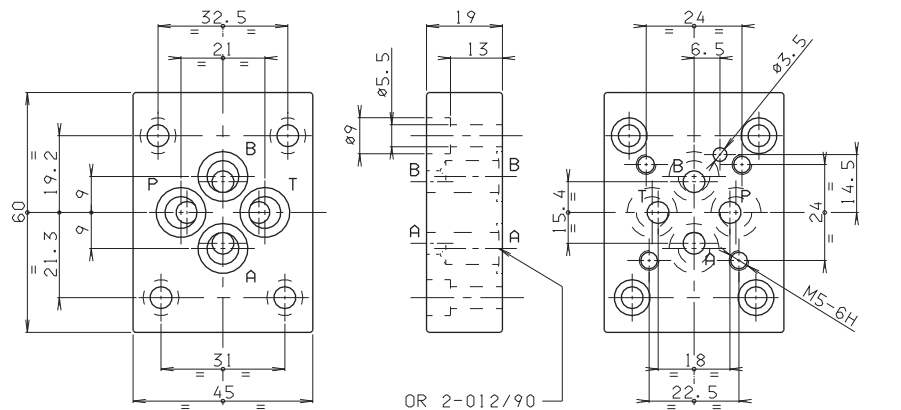

7

# BC.2... MODULAR COMPONENTS

## BC250AB INTERMEDIATE MODULE FOR PRESSURE GAUGE CONNECTION (VENTS A AND B LINES)

- BC** Module base
- 2** CETOP 2/NG4
- 50** Intermediate module for pressure gauge connection
- AB** Check at ports A and B
- 00** No variant
- 1** Serial No.

Weight: 0,4 Kg

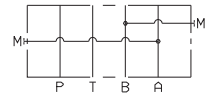
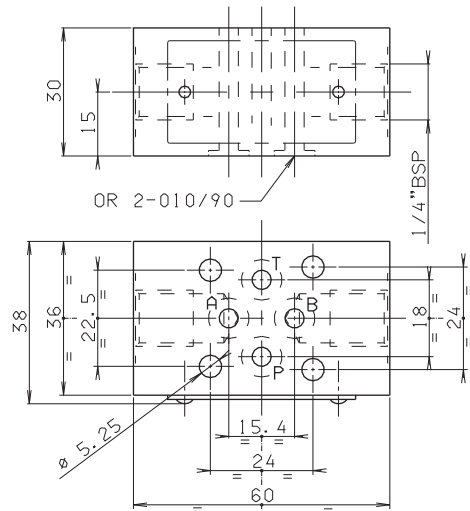

## BC250PT INTERMEDIATE MODULE FOR PRESSURE GAUGE CONNECTION (VENTS P AND T LINES)

- BC** Module base
- 2** CETOP 2/NG4
- 50** Intermediate module for pressure gauge connection
- PT** Check at ports P and T
- 00** No variant
- 1** Serial No.

Weight: 0,4 Kg

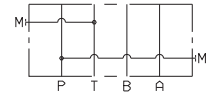
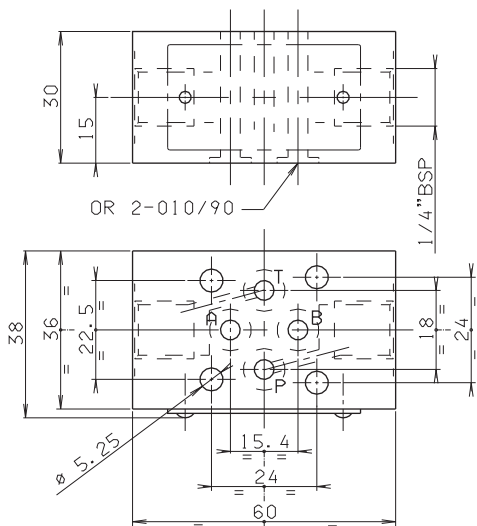

## BC251 DOWEL CARRIER PLATE FOR SOLENOID VALVE

- BC** Module base
- 2** CETOP 2/NG4
- 51** Dowel carrier plate for solenoid valve
- 00** No variant
- 1** Serial No.

Weight: 0,05 Kg

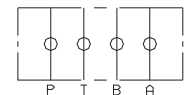
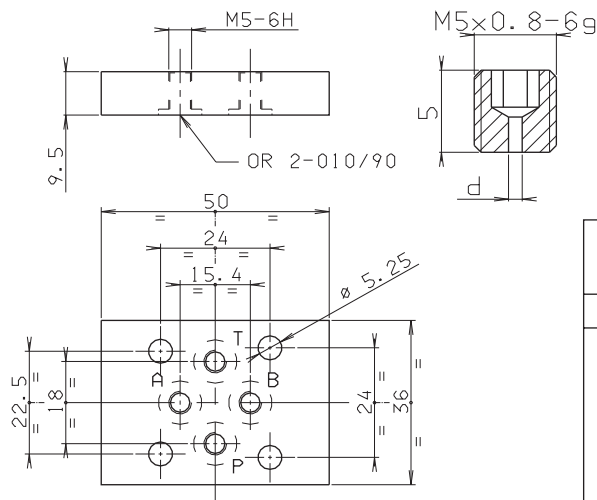

CALIBRATED DIAPHRAGMS AVAILABLE	
d	M5x0.8x5
0.5	M89.10.0044
0.6	M89.10.0045
0.7	M89.10.0046
0.8	M89.10.0015
0.9	M89.10.0047
1	M89.10.0048
1.2	M89.10.0049

# BM2... MULTI STATION SUBPLATE

## BM250/60/70

- BM** Multi station subplate (supplied in aluminium material)
- 2** CETOP 2/NG4
- \*\*** **50** = Connected in parallel with pressure relief valve and rear connectors  
**70** = Connected in parallel with pressure relief valve and side connectors  
**60** = Connected in parallel without pressure relief valve and side connectors
- \*** No. of valve seats  
**2 / 3 / 4 / 5 / 6 / 7 / 8**
- C** Type of adjustment (omit for 60 version)  
 Grub screw
- \*** Setting range (omit for 60 version)  
**1** = max. 30 bar (**white spring**)  
**2** = max. 90 bar (**yellow spring**)  
**3** = max. 180 bar (**green spring**)  
**4** = max. 250 bar (**orange spring**)
- \*\*** **00** = No variant  
**V1** = Viton
- 1** Serial No.

•The minimum permissible setting pressure depending on the spring:  
 see cartridge valve type CMP02...

## BM260 CONNECTED IN PARALLEL WITHOUT PRESSURE RELIEF VALVE

Type	A	B	Weight(Kg)
BM260/2	105	91	0,64
BM260/3	145	131	0,87
BM260/4	185	171	1,10
BM260/5	225	211	1,33
BM260/6	265	251	1,56
BM260/7	305	291	1,79
BM260/8	345	331	2,02

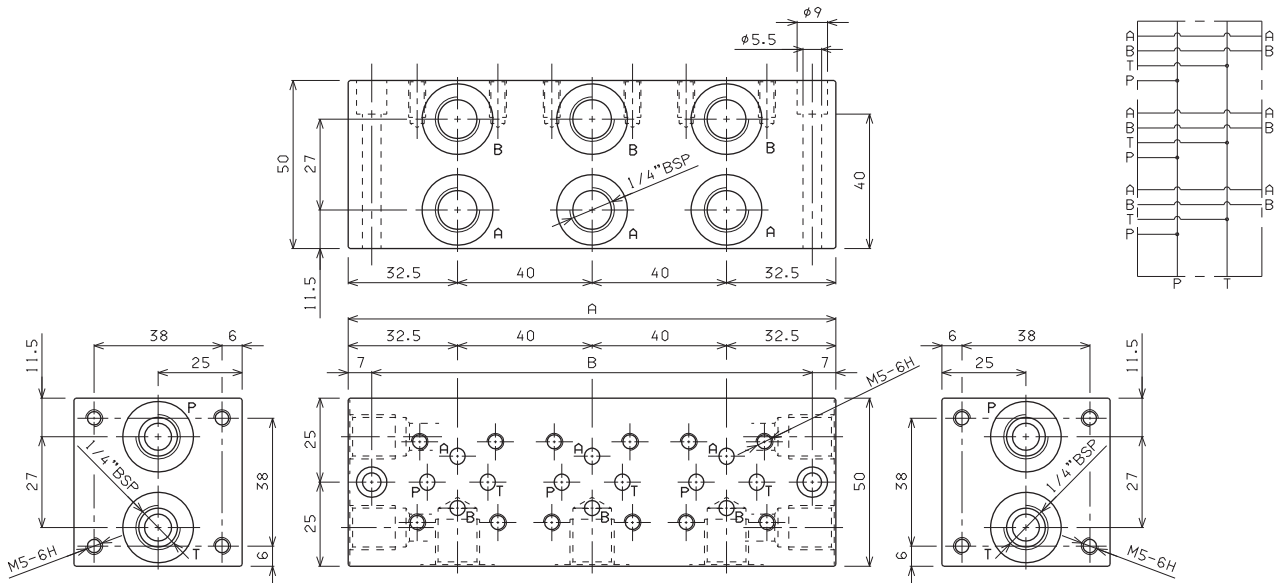

Fixing screws M5x50 UNI 5931

# BM2... MULTI STATION SUBPLATE

## BM250 CONNECTED IN PARALLEL WITH PRESSURE RELIEF VALVE

Type	A	B	Weight(Kg)
BM250/2	130	116	0,70
BM250/3	170	156	0,93
BM250/4	210	196	1,16
BM250/5	250	236	1,39
BM250/6	290	276	1,62
BM250/7	330	316	1,85
BM250/8	370	356	2,08

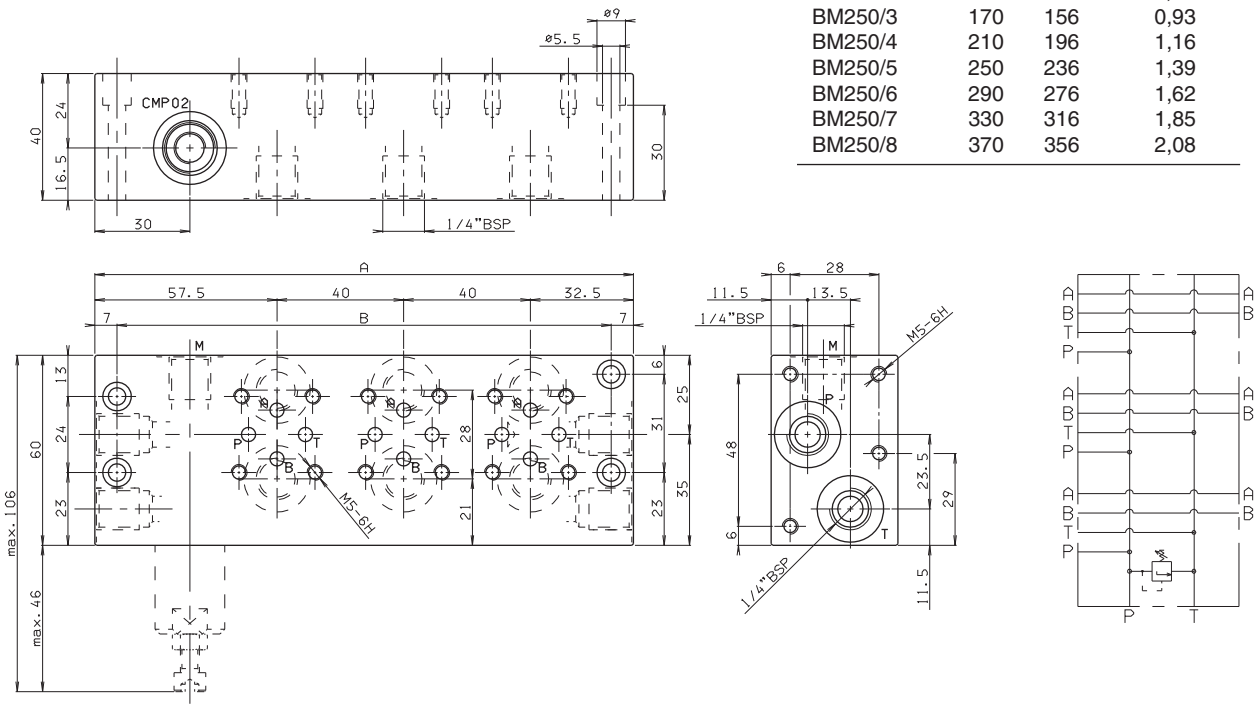

Fixing screws M5x40 UNI 5931

7

## BM270 CONNECTED IN PARALLEL WITH PRESSURE RELIEF VALVE

Type	A	B	Weight(Kg)
BM270/2	130	116	0,93
BM270/3	170	156	1,16
BM270/4	210	196	1,39
BM270/5	250	236	1,62
BM270/6	290	276	1,85
BM270/7	330	316	2,08
BM270/8	370	356	2,31

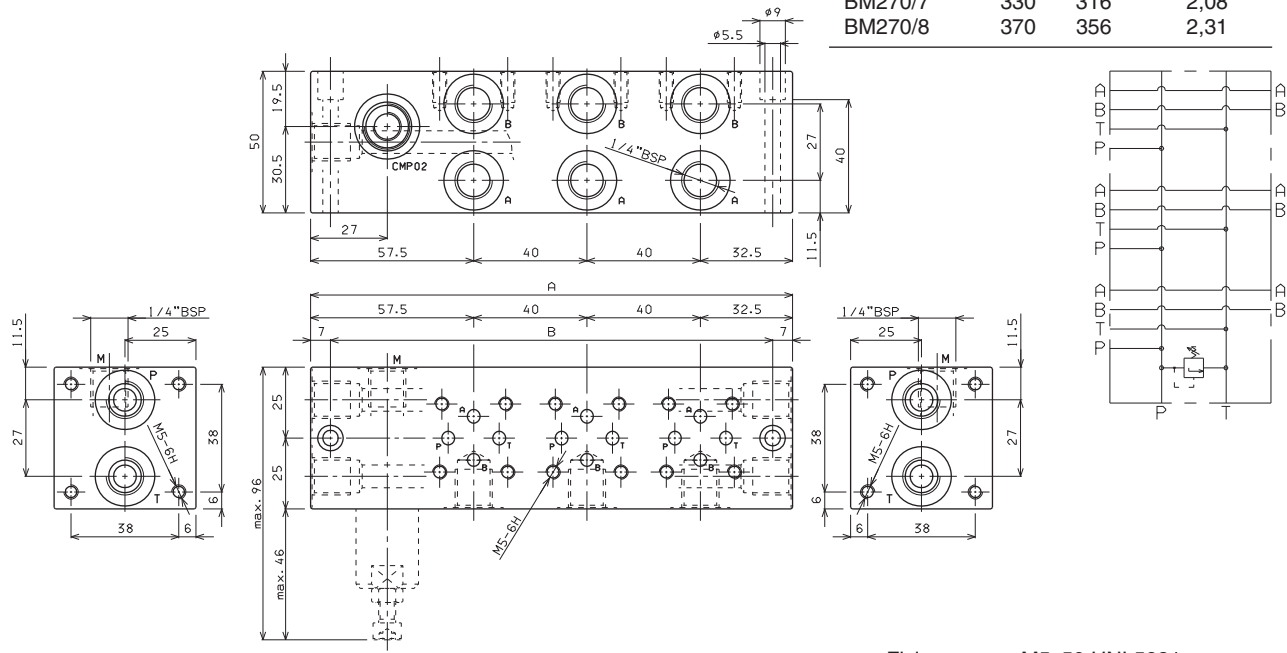

Fixing screws M5x50 UNI 5931

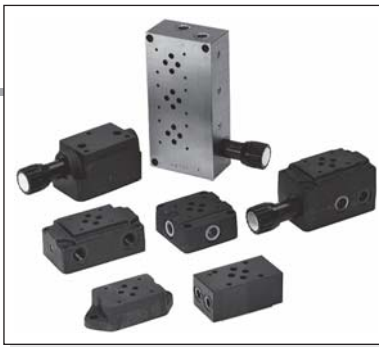

**CETOP 3 SUBPLATES**

BS301... / BS30*...	CAP. VII • 7
BS310/11... / BS312/13...	
BS314/15... / BS316/17...	CAP. VII • 8
BS320/21... / BSVMP10...	
BS3W...	CAP. VII • 9
BC325/27... / BC330/32...	
BC340...	CAP. VII • 10
BC341/*...	
BC350... / BC351...	
BC307... / BC3107...	CAP. VII • 12
BC308... / BC309...	
BC06XQ3... / BC06XQP3...	CAP. VII • 13
BC0625/27...	CAP. VII • 14
BC0630/32... / BC0640...	
BC0641/*...	CAP. VII • 15
BM3.**... / BM360...	CAP. VII • 16
BM350... / BM370...	CAP. VII • 17
BM352... / BM372...	CAP. VII • 18
CMP10...	CAP. VII • 30
XQ3...	CAP. VII • 20
XQP3...	CAP. VII • 22

**BS3... SINGLE STATION SUBPLATE**

**BS301...**

- BS** Single subplate (blanking)
- 3** CETOP 3/NG6
- 01** P / T / A / B closed
- 00** No variant
- 1** Serial No.

Weight: 0,2 Kg  
 Fixing screws M5x14 UNI 5931  
 K = plate OR (Q25.95.0001)

Use for pressures up to 200 bar.

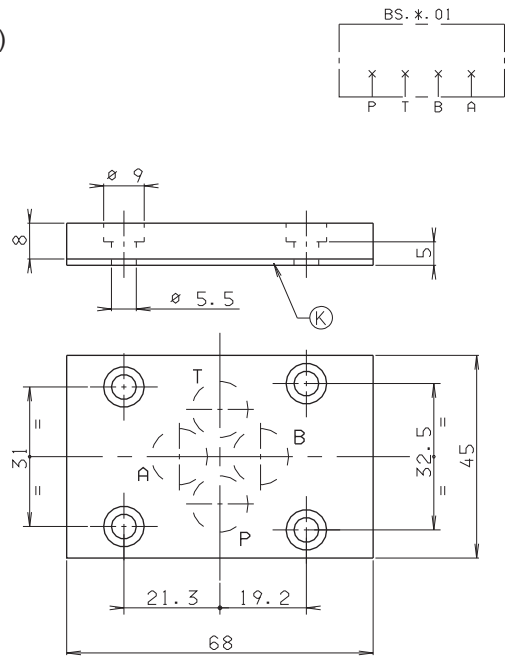

**BS3\*\*...**

- BS** Single subplate (blanking)
- 3** CETOP 3/NG6
- \*\*** 02/03/04/05/06/07/08/09
- 00** No variant
- 1** Serial No.

Weight: 0,5 Kg  
 Fixing screws M5x30 UNI 5931

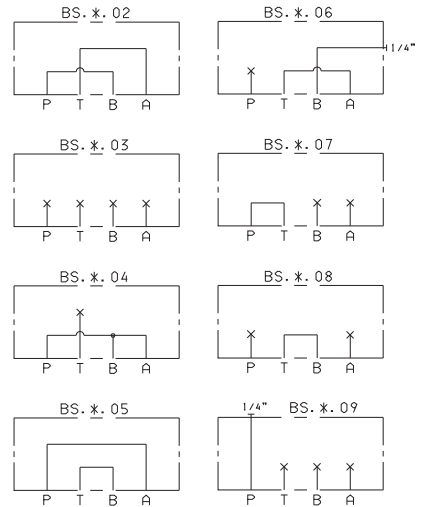
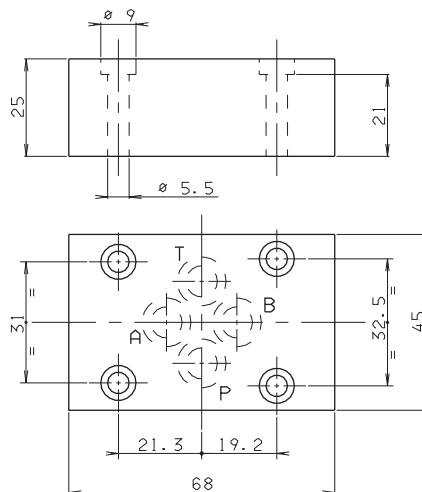

# BS3... SINGLE STATION SUBPLATE

## BS310/11... (REAR CONNECTORS)

- BS** Single subplate
- 3** CETOP 3/NG6
- \*\*** **10** = 1/8" BSP rear connectors  
**11** = 1/4" BSP rear connectors
- 00** No variant
- 1** Serial No.

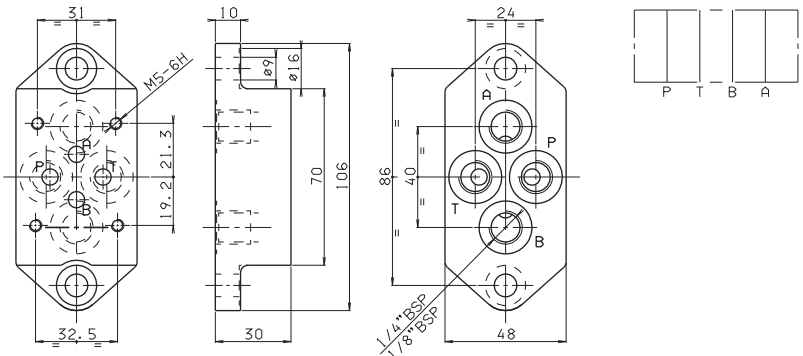

Weight: 0,7 Kg - Fixing screws M8x20 UNI 5931

## BS312/13 (REAR CONNECTORS)

- BS** Single subplate
- 3** CETOP 3/NG6
- \*\*** **12** = 3/8" BSP rear connectors  
**13** = 1/4" BSP rear connectors
- 00** No variant
- 1** Serial No.

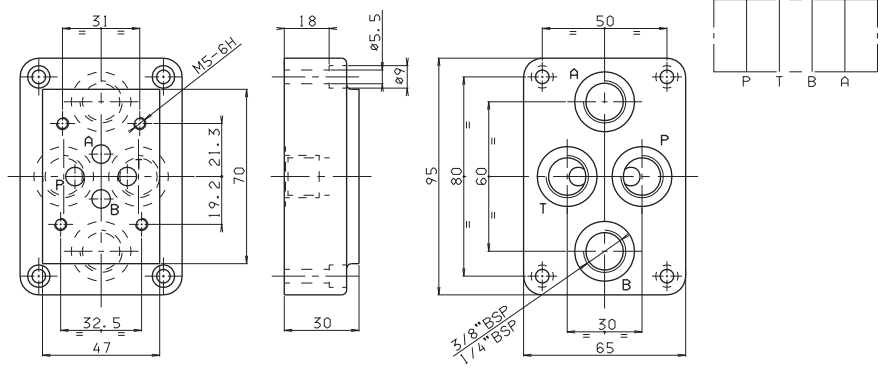

Weight: 1 Kg - Fixing screws M5x25 UNI 5931

## BS314/15 (SIDE CONNECTORS)

- BS** Single subplate
- 3** CETOP 3/NG6
- \*\*** **14** = 3/8" BSP side connectors (\*)  
**15** = 1/4" BSP side connectors (\*)
- 00** No variant
- 1** Serial No.

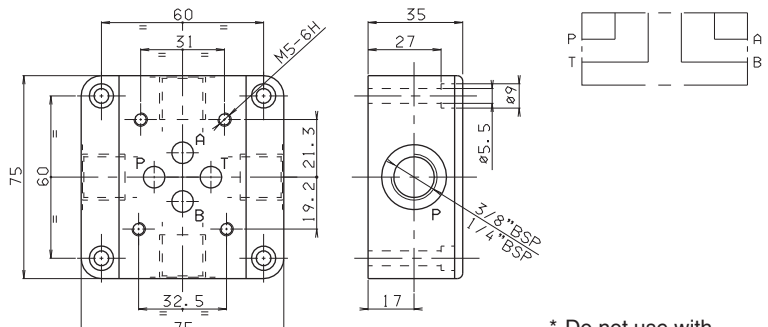

Weight: 1,2 Kg - Fixing screws M5x35 UNI 5931

\* Do not use with XQP3C3-D---2

## BS316/17 (CONNECTORS SIDE A AND B, REAR P AND T)

- BS** Single subplate
- 3** CETOP 3/NG6
- \*\*** **16** = 3/8" BSP rear and side connectors  
**17** = 1/4" BSP rear and side connectors
- 00** No variant
- 1** Serial No.

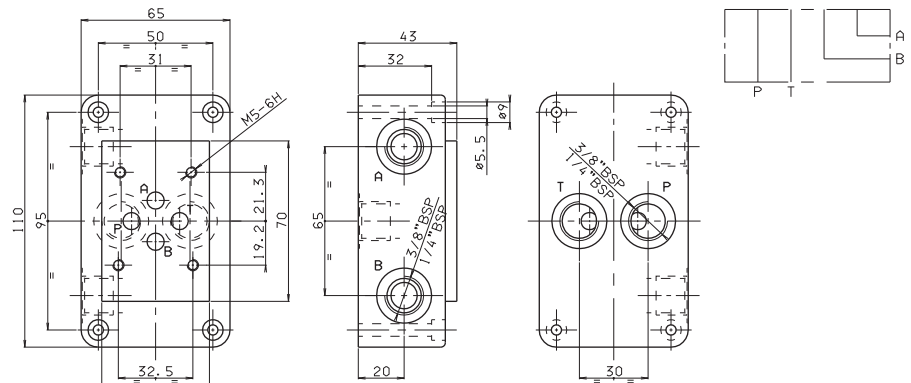

Weight: 1,8 Kg - Fixing screws M5x40 UNI 5931

7

# BS3... SINGLE STATION SUBPLATE

## BS320/21 (CONNECTORS SIDE A AND B, REAR P AND T)

- BS** Single subplate
- 3** CETOP 3/NG6
- \*\*** **20** = 3/8" BSP rear and side connectors  
**21** = 1/4" BSP rear and side connectors
- \*** **M** = Plastic knob  
**C** = Grub screws
- \*** Setting range  
**1** = max. 50 bar (**white spring**)  
**2** = max. 150 bar (**yellow spring**)  
**3** = max. 320 bar (**green spring**)
- 00** No variant
- 1** Serial No.

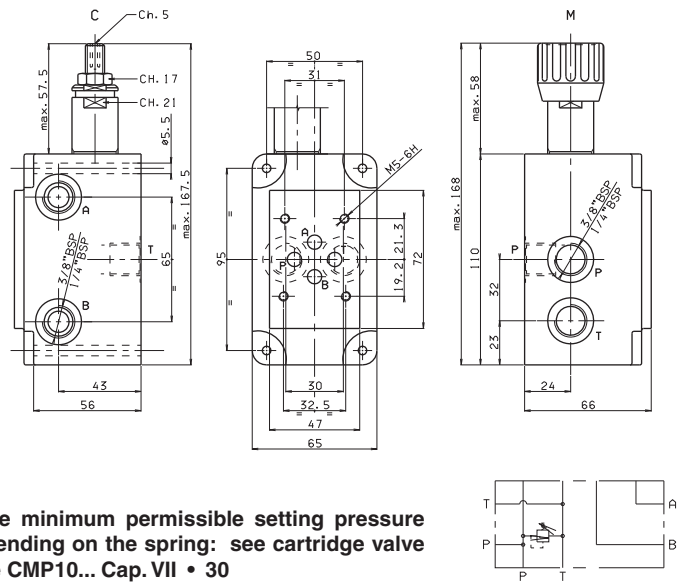

• The minimum permissible setting pressure depending on the spring: see cartridge valve type CMP10... Cap. VII • 30

Weight: 2,9 Kg - Fixing screws M5x65 UNI 5931

## BSVMP10 SINGLE STATION SUBPLATE WITH MAX. PRESSURE VALVE FOR SURFACE MOUNTING (E.G. ON TAKE COVER)

- BS** Single subplate
- VMP** Max. pressure valve
- 10** 3/8" BSP connectors
- \*** **M** = Plastic knob  
**C** = Grub screw  
**V** = Handwheel
- \*** Setting range  
**1** = max. 50 bar (**white spring**)  
**2** = max. 150 bar (**yellow spring**)  
**3** = max. 320 bar (**green spring**)
- 00** No variant
- 1** Serial No.

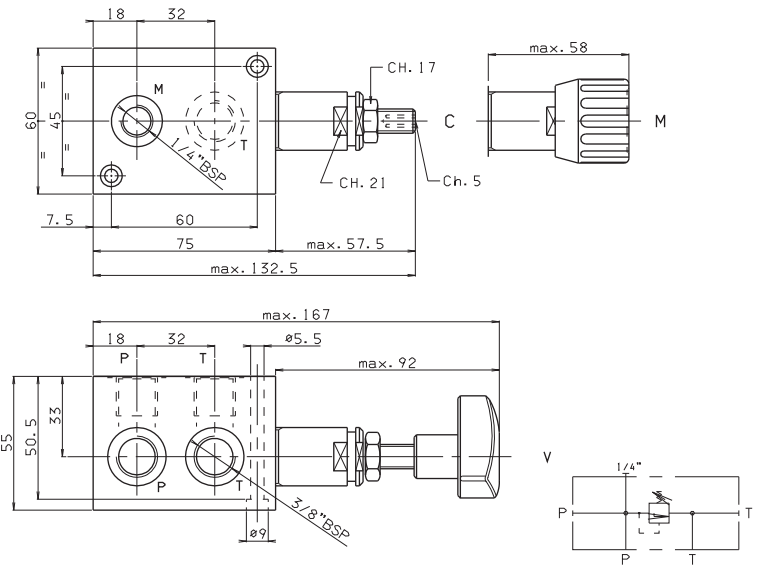

• The minimum permissible setting pressure depending on the spring: see cartridge valve type CMP10... Cap. VII • 30

Weight: 1,6 Kg  
Fixing screws M5x60 UNI 5931

## BS3W...

- BS** Single subplate
- 3** CETOP 3/NG6
- W** Wheatstone bridge
- 00** No variant
- 1** Serial No.

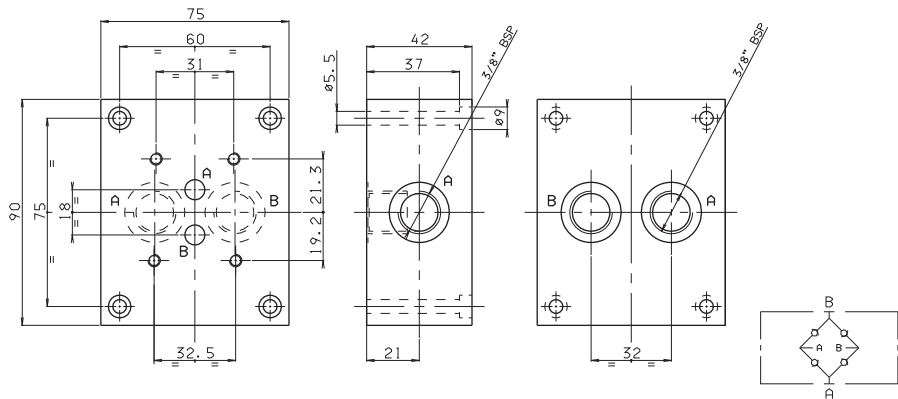

Weight: 1,8 Kg  
Fixing screws M5x45 UNI 5931

7

BC325/27 P/T REAR AND SIDE CONNECTORS 1/2" BSP- 3 RODS

- BC** Module base
- 3** CETOP 3/NG6
- \*\*** **25** = 1/2" BSP rear and side connectors with CMP  
**27** = 1/2" BSP rear and side connectors without CMP
- \*** Adjustment (omit for 27 version)  
**M** = Plastic knob  
**C** = Grub screw
- \*** Setting range (omit for 27 version)  
**1** = max. 50 bar (**white spring**)  
**2** = max. 150 bar (**yellow spring**)  
**3** = max. 320 bar (**green spring**)
- 00** No variant
- 1** Serial No.

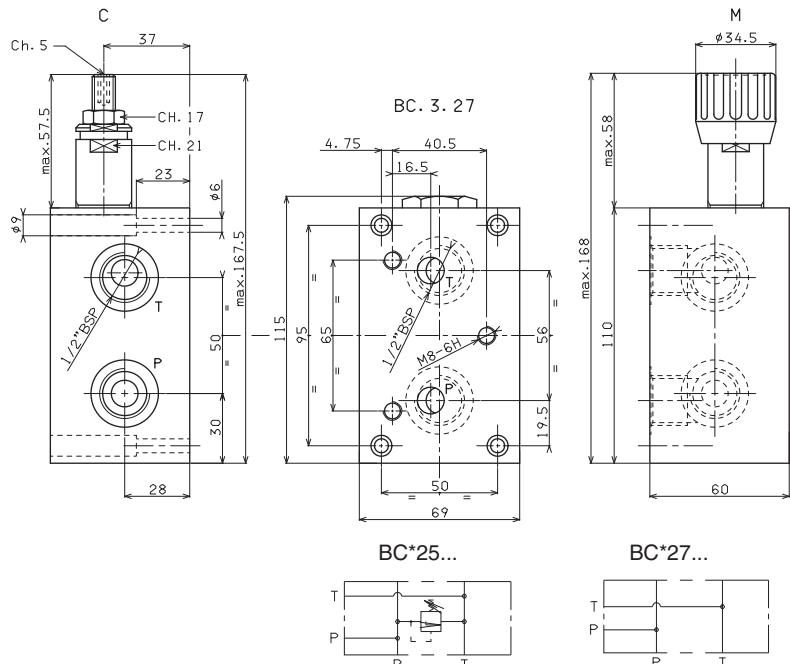

Weight BC.3.25: 2,7 Kg  
Weight BC.3.27: 2,6 Kg  
Fixing screws M5x30 UNI 5931

• The minimum permissible setting pressure depending on the spring:  
see cartridge valve type CMP10... Cap. VII • 30

BC330/32 - 3 RODS

- BC** Module base
- 3** CETOP 3/NG6
- \*\*** **30** = 3/8" BSP connectors in parallel  
**32** = 3/8" BSP connectors in series
- 00** No variant
- 1** Serial No.

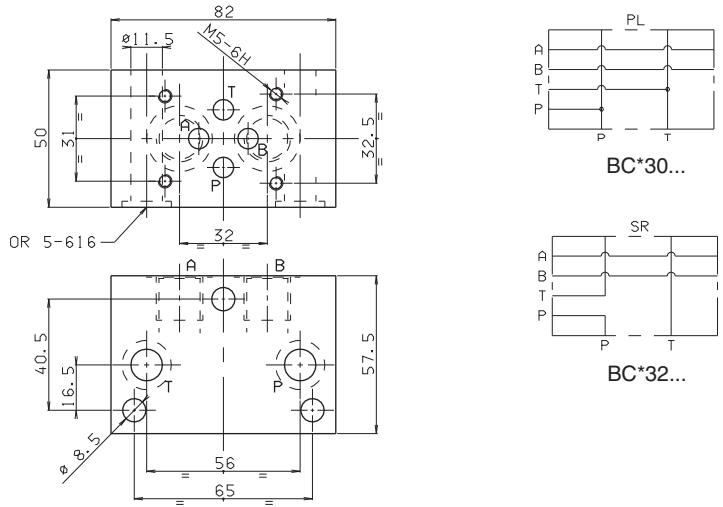

Weight Kg. 1,4

BC340 - 3 RODS

- BC** Module base
- 3** CETOP 3/NG6
- 40** Blanking
- 00** No variant
- 1** Serial No.

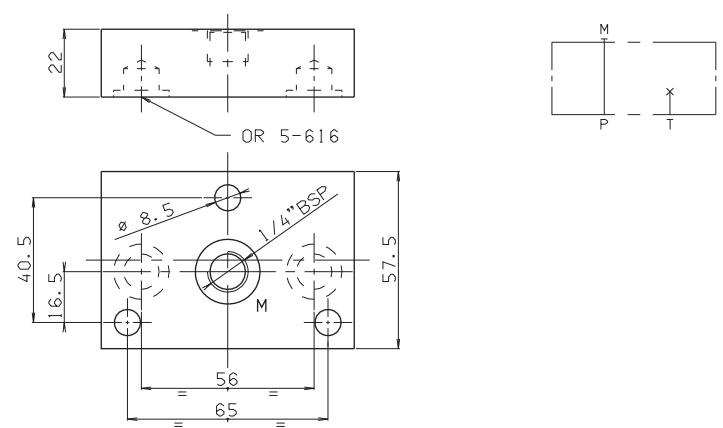

Weight: 0,7 Kg

7



# BC3... MODULAR COMPONENTS

## ASSEMBLED MODULAR COMPONENT BASES - 3 RODS

Rods code	L	Composition
BC341/2	M80200010 146	BC325/27 + 2 BC330/32 + BC340
BC341/3	M80200011 196	BC325/27 + 3 BC330/32 + BC340
BC341/4	M80200012 246	BC325/27 + 4 BC330/32 + BC340
BC341/5	M80200013 296	BC325/27 + 5 BC330/32 + BC340
BC341/6	M80200014 346	BC325/27 + 6 BC330/32 + BC340
BC341/7	M80200015 396	BC325/27 + 7 BC330/32 + BC340
BC341/8	M80200016 446	BC325/27 + 8 BC330/32 + BC340
<b>Nuts code</b>	Q26560514	
<b>Pieces</b>	3	

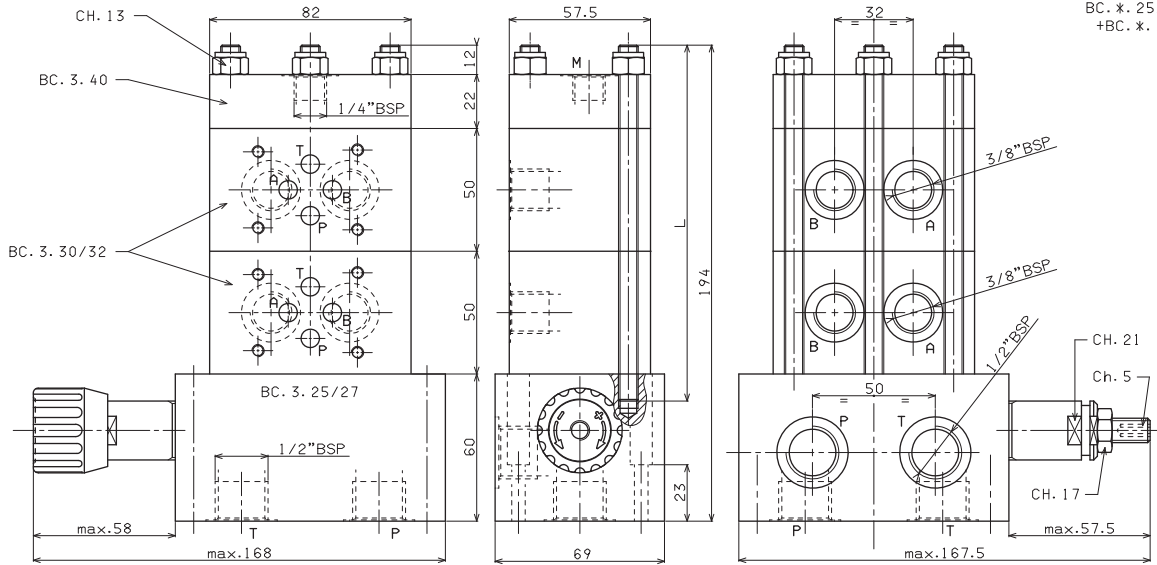
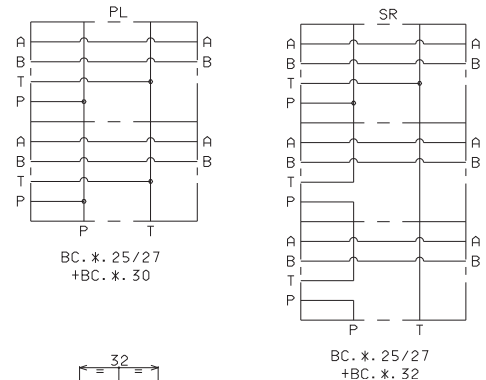

- For series connection the last block high up should be connected in parallel (BC330)
- Single components should be ordered separately
- The minimum permissible setting pressure depending on the spring: see cartridge valve type CMP10... Cap. VII • 30

## BC341/\* RODS FOR MODULAR ASSEMBLY

Rod code	Pieces	L	Composition
BC341/2001	3	146	for 2 solenoid valves
BC341/3001	3	196	for 3 solenoid valves
BC341/4001	3	246	for 4 solenoid valves
BC341/5001	3	296	for 5 solenoid valves
BC341/6001	3	346	for 6 solenoid valves
BC341/7001	3	396	for 7 solenoid valves
BC341/8001	3	446	for 8 solenoid valves

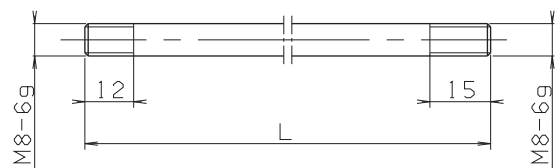

Tightening torque: 23 Nm ( $\pm 2$  Nm)

# BC3... MODULAR COMPONENTS

## BC350 INTERMEDIATE MODULE FOR PRESSURE GAUGE CONNECTION

- BC** Module base
- 3** CETOP 3/NG6
- 50** Intermediate module for pressure gauge connection at ports A/B/P/T
- 00** No variant
- 1** Serial No.

Weight: 1 Kg

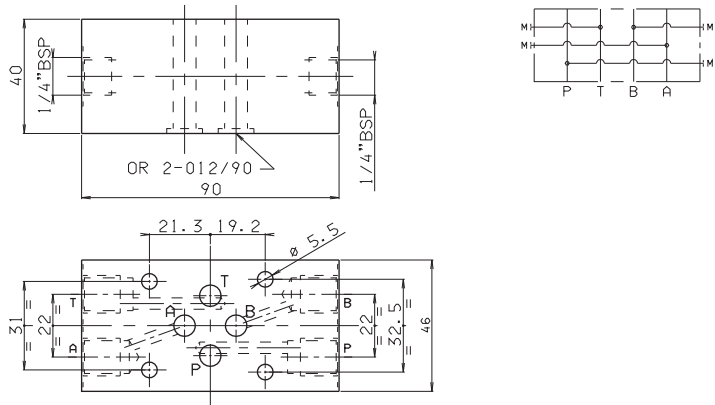

## BC351 DOWEL BASE PLATE FOR SOLENOID VALVE

- BC** Module base
- 3** CETOP 3/NG6
- 51** Dowel base plate
- 00** No variant
- 1** Serial No.

Weight: 0,2 Kg

K = plate OR (Q25.95.0001)

CALIBRATED DIAPHRAGMS AVAILABLE	
d	M8x1x8
0.6	M89100007
0.7	M89100008
0.8	M89100009
0.9	M89100012
1	M89100010
1.2	M89100011
1.4	M89100038
1.5	M89100035
1.75	M89100042
2	M89100041
2.5	M89100036

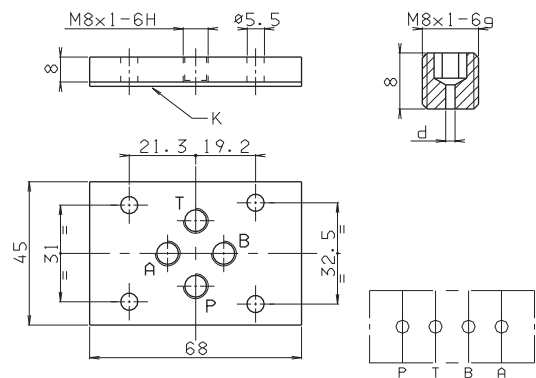

7

## BC307 BASE PLATE FOR DOUBLE FLOW RATE P→A AND B→T

- BC** Module base
- 3** CETOP 3/NG6
- 07** bases plate for twin flow rate
- 00** No variant
- 1** Serial No.

Weight: 0,5 Kg

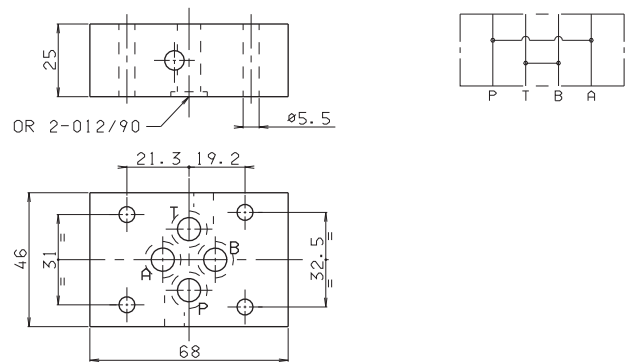

## BC3107 BASE PLATE FOR USING 4 WAY VALVE AS 2 WAY ONLY

- BC** Module base
- 3** CETOP 3/NG6
- 107** base for using 4 way valve as 2 way only
- 00** No variant
- 1** Serial No.

Weight: 0,5 Kg

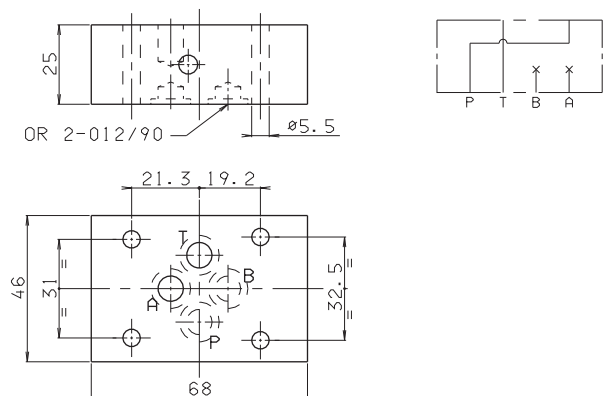

**BC308 INTERMEDIATE BASE PLATE FOR XQ3... (P → A)**

- BC** Module base
- 3** CETOP 3/NG6
- 08** Base plate for XQ3 ( P→A)
- 00** No variant
- 1** Serial No.

Weight: 1,5 Kg

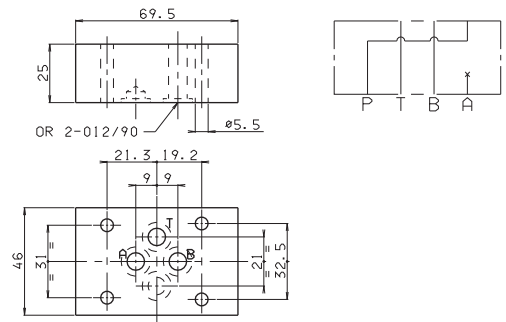

**BC309 INTERMEDIATE BASE PLATE FOR XQ3... (B → P)**

- BC** Module base
- 3** CETOP 3/NG6
- 09** Base plate for XQ3 ( B→P)
- 00** No variant
- 1** Serial No.

Weight: 1,4 Kg

• To take advantage of this base it is necessary to operate with the pump at connector A of the multi station base plate

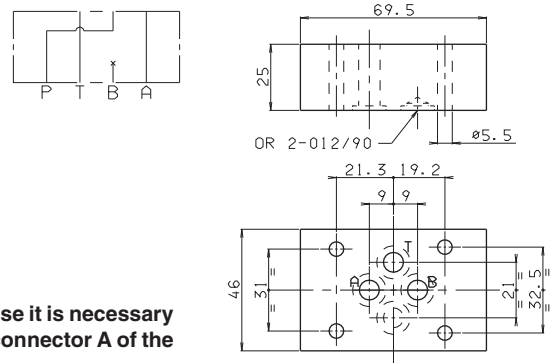

**BC06XQ3 BASE PLATE FOR PROPORTIONAL VALVE TYPE XQ3...**

- BC** Module base
- 06** CETOP 3/NG6
- XQ3** base plate XQ3
- 00** No variant
- 1** Serial No.

Weight: 1,4 Kg

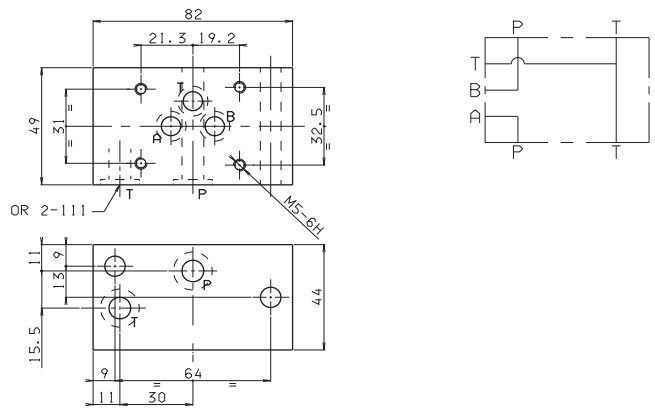

7

**BC06XQP3 BASE PLATE FOR PROPORTIONAL REGULATOR TYPE XQP3...**

- BC** Module base
- 06** CETOP 3/NG6
- XQP3** Base for XQP3 proportional regulator
- 00** No variant
- 1** Serial No

Weight: 1,4 Kg

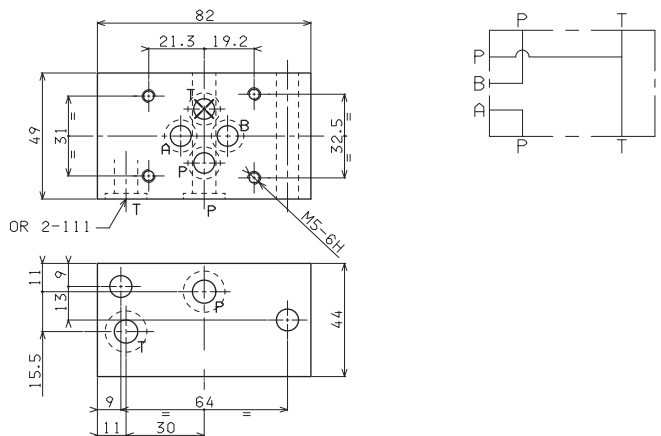

# BC.06... MODULAR COMPONENTS

## BC0625/27 P AND T REAR AND SIDE CONNECTORS 3/8" BSP - 2 RODS

- BC** Module base
- 06** CETOP 3/NG6
- \*\*** **25** = 3/8" BSP rear and side connectors with CMP  
**27** = 3/8" BSP rear and side connectors without CMP
- \*** Adjustment (omit for BC0627 version)  
**M** = Plastic knob  
**C** = Grub screw
- \*** Setting range (omit for BC0627 version)  
**1** = max. 50 bar (**white spring**)  
**2** = max. 150 bar (**yellow spring**)  
**3** = max. 320 bar (**green spring**)
- 00** No variant
- 1** Serial No.

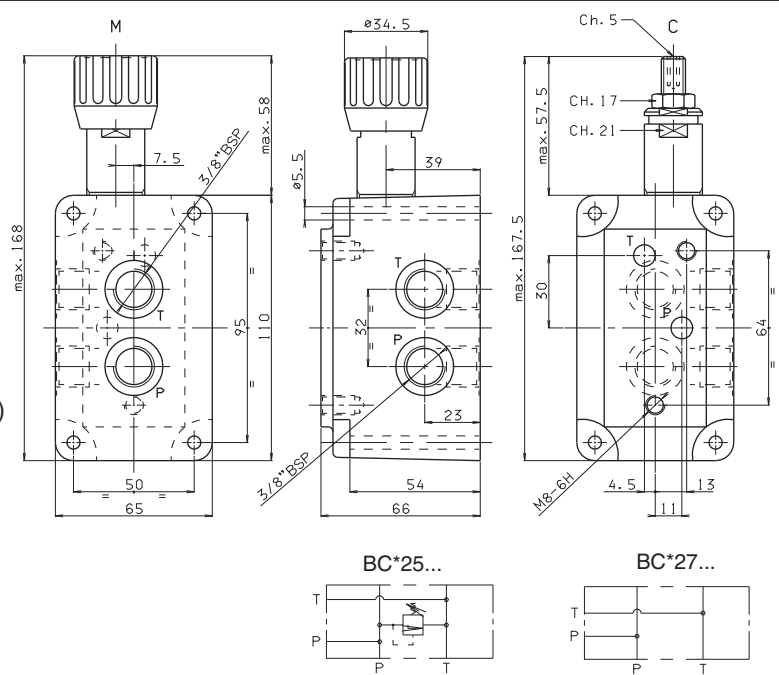

Weight BC325 : 3 Kg  
 Weight BC327 : 2,8 Kg  
 Fixing screws M5x65 UNI 5931

• The minimum permissible setting pressure depending on the spring:  
 see cartridge valve type CMP10... Cap. VII • 30

## ASSEMBLED MODULAR COMPONENT BASES - 2 RODS

Rods code	L	Composition
BC0641/2 M80200001	138	BC0625/27 + 2 BC0630/32 + BC0640
BC0641/3 M80200002	187	BC0625/27 + 3 BC0630/32 + BC0640
BC0641/4 M80200003	236	BC0625/27 + 4 BC0630/32 + BC0640
BC0641/5 M80200004	285	BC0625/27 + 5 BC0630/32 + BC0640
BC0641/6 M80200005	334	BC0625/27 + 6 BC0630/32 + BC0640
BC0641/7 M80200006	382	BC0625/27 + 7 BC0630/32 + BC0640
BC0641/8 M80200007	430	BC0625/27 + 8 BC0630/32 + BC0640

**Nuts code** Q26560514  
**Pieces** 2

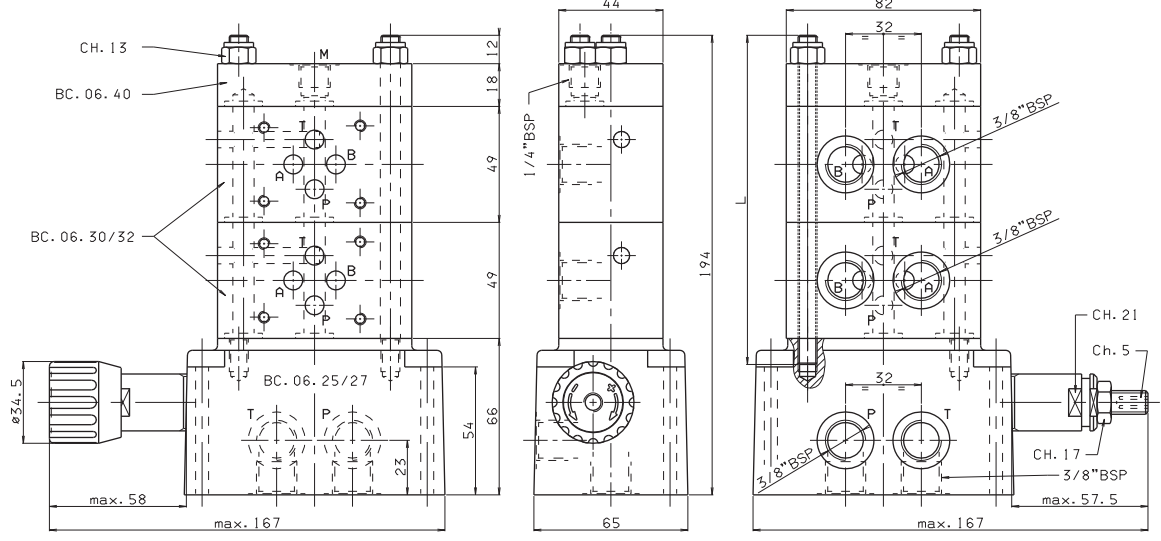
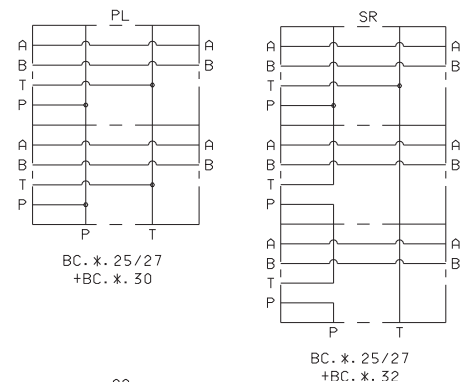

- For series connection the last block high up should be connected in parallel (BC0630)
- Single components should be ordered separately
- The minimum permissible setting range depending on the spring: see cartridge valve type CMP.10... Cap. VII • 30

7

**BC0630/32 - 2 RODS**

- BC** Module base
- 06** CETOP 3/NG6
- \*\*** **30** = 3/8" BSP connectors in parallel  
**32** = 3/8" BSP connectors in series
- 00** No variant
- 1** Serial No.

Weight: 1,1 Kg

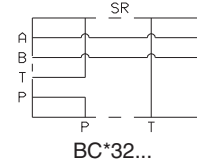
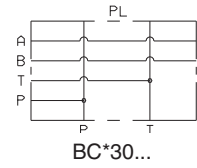
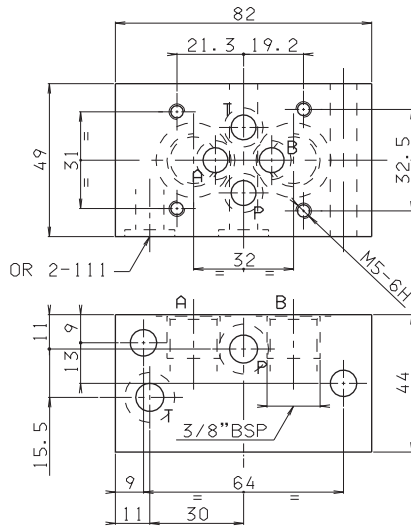

**BC0640 - 2 RODS**

- BC** Module base
- 06** CETOP 3/NG6 - 2 rods
- 40** Blanking
- 00** No variant
- 1** Serial No.

Weight: 0,4 Kg

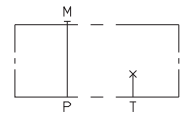
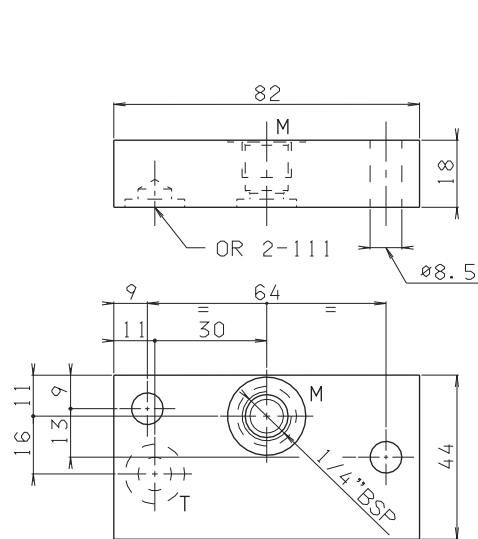

**BC0641/\* RODS FOR MODULAR ASSEMBLY**

Rod code	Pieces	L	Composition
BC0641/2001	2	138	for 2 solenoid valves
BC0641/3001	2	187	for 3 solenoid valves
BC0641/4001	2	236	for 4 solenoid valves
BC0641/5001	2	285	for 5 solenoid valves
BC0641/6001	2	334	for 6 solenoid valves
BC0641/7001	2	382	for 7 solenoid valves
BC0641/8001	2	430	for 8 solenoid valves

Tightening torque: 23 Nm (±2 Nm)

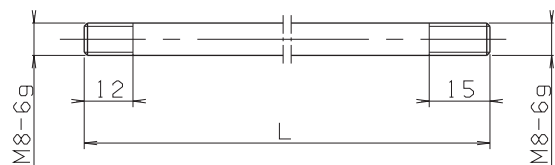

# BM3... MULTI STATION SUBPLATE

## BM3...

- BM** Multi station subplate (standard versions are supplied in cast iron material)
- 3** CETOP 3/NG6
- \*\***
  - 50** = Connected in parallel with pressure relief valve and rear connectors
  - 70** = Connected in parallel with pressure relief valve and side connectors
  - 52** = Connected in series with pressure relief valve and rear connectors
  - 72** = Connected in series with pressure relief valve and side connectors
  - 60** = Connected in parallel without pressure relief valve and side connectors
- \*** No. of valve seats  
**2 / 3 / 4 / 5 / 6 / 7 / 8**
- \*** Type of adjustment (omit for BM360 version)  
**M** = Plastic knob  
**C** = Grub screw
- \*** Setting range (omit for BM360 version)  
**1** = max. 50 bar (**white spring**)  
**2** = max. 150 bar (**yellow spring**)  
**3** = max. 320 bar (**green spring**)
- \*\*** **00** = No variant  
**AL** = in aluminium material versions (recommended pressure max. 230 bar)
- 1** Serial No.

• The minimum permissible setting pressure depending on the spring:  
see cartridge valve type CMP10... Cap. VII • 30

7

## BM360 CONNECTED IN PARALLEL WITHOUT PRESSURE RELIEF VALVE

Type	A	B	Weight(Kg)
BM360/2	120	108	3,6
BM360/3	170	158	5,1
BM360/4	220	208	6,7
BM360/5	270	258	8,2
BM360/6	320	308	9,7
BM360/7	370	358	11,2
BM360/8	420	408	12,6

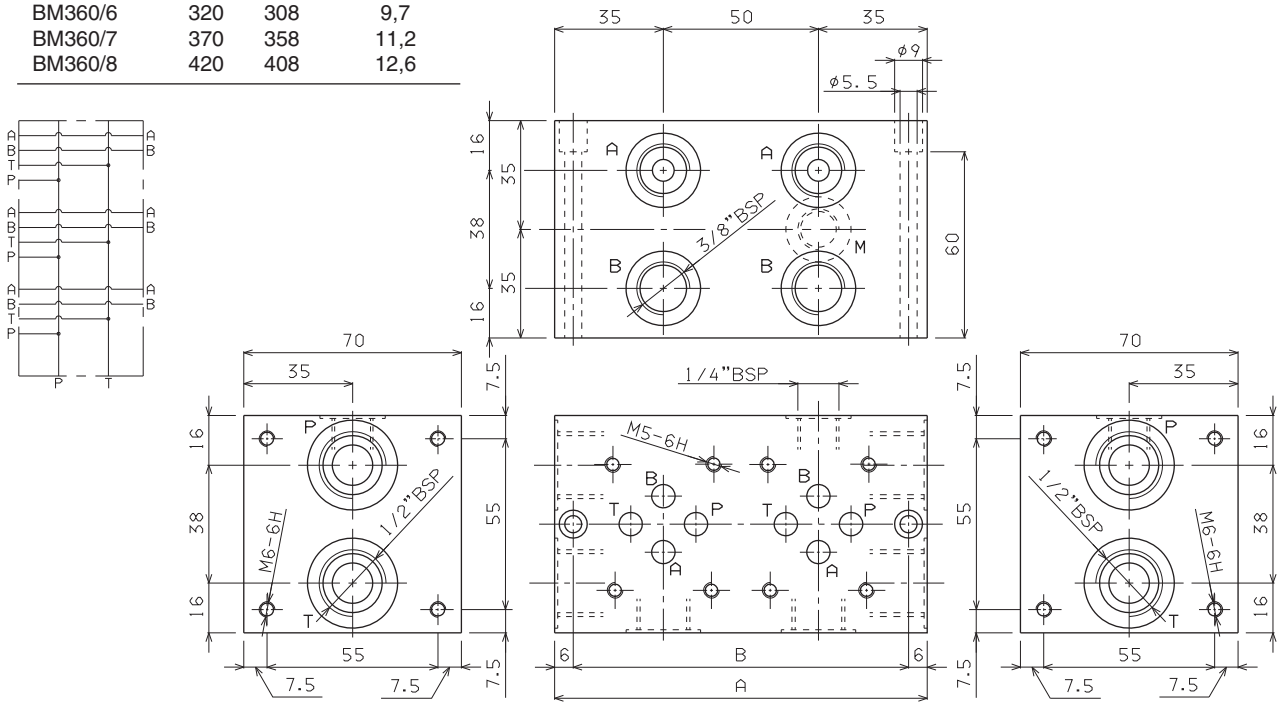

Fixing screws M5x70 UNI 5931

# BM3... MULTI STATION SUBPLATE

## BM350 CONNECTED IN PARALLEL WITH PRESSURE RELIEF VALVE

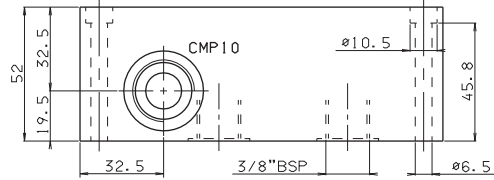
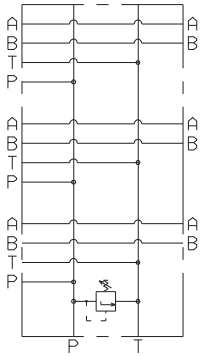

Type	A	B	Weight(Kg)
BM350/2	141	126	4,6
BM350/3	191	176	6,1
BM350/4	241	226	7,6
BM350/5	291	276	9,1
BM350/6	341	326	10,6
BM350/7	391	376	12,1
BM350/8	441	426	13,6

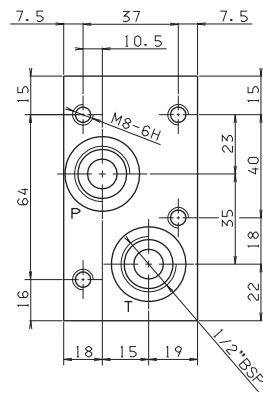
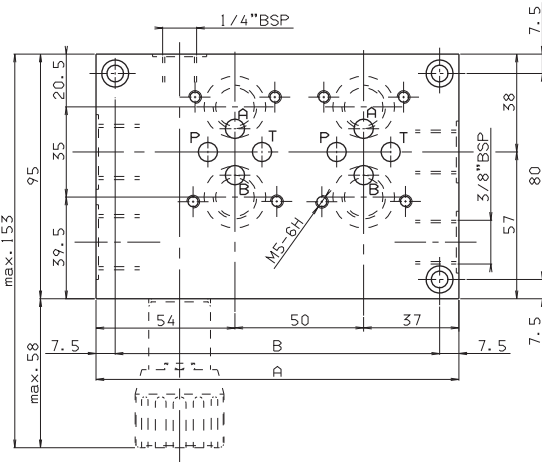
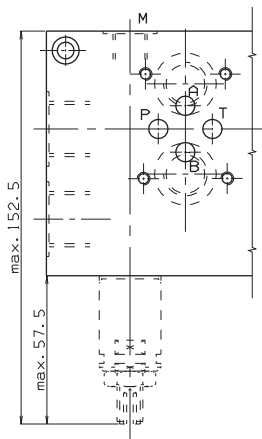

Fixing screws M6x55 UNI 5931

## BM370 CONNECTED IN PARALLEL WITH PRESSURE RELIEF VALVE

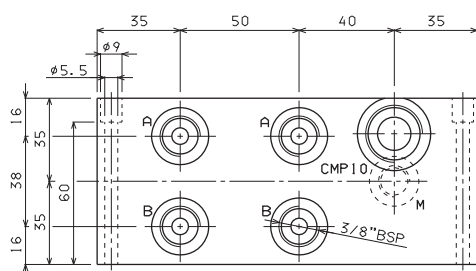
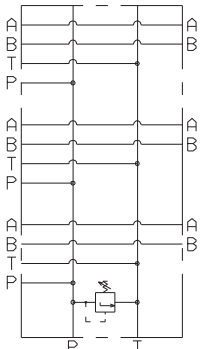

Type	A	B	Weight(Kg)
BM370/2	160	148	4,9
BM370/3	210	198	6,4
BM370/4	260	248	7,9
BM370/5	310	298	9,4
BM370/6	360	348	10,9
BM370/7	410	398	12,4
BM370/8	460	448	13,9

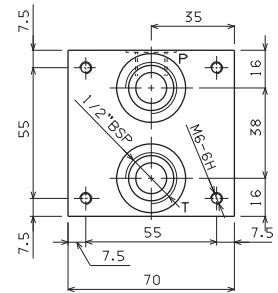
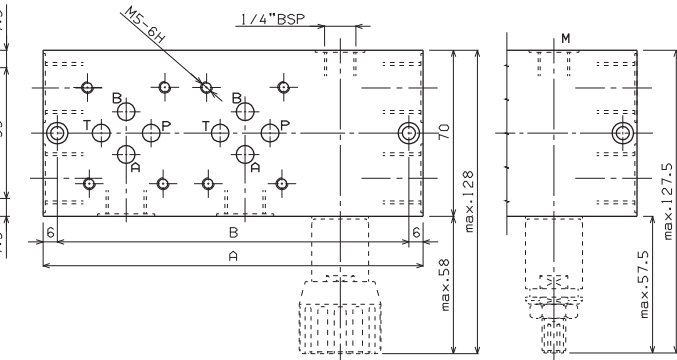
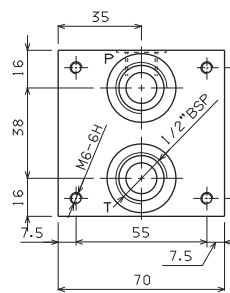

Fixing screws M5x70 UNI 5931

# BM3... MULTI STATION SUBPLATE

## BM352 CONNECTED IN SERIES WITH PRESSURE RELIEF VALVE

Technical drawing of the BM352 subplate. It includes a top view showing a grid of ports labeled P, T, and M, with dimensions for overall size (max. 152.5 x max. 57.5) and individual port spacing. A side view shows the subplate's profile with a height of 46 and a 3/8" BSP connection. A detail view shows a port with a 1/4" BSP connection and an M5-6H screw. Another detail view shows a port with an M8-6H screw and a 1/2" BSP connection. A pressure relief valve (CMP 10) is also indicated.

Type	A	B	Weight(Kg)
BM352/2	141	126	4,6
BM352/3	191	176	6,3
BM352/4	241	226	7,6
BM352/5	291	276	9,2
BM352/6	341	326	10,7
BM352/7	391	376	12,2
BM352/8	441	426	13,7

Fixing screws M6x55 UNI 5931

7

## BM372 CONNECTED IN SERIES WITH PRESSURE RELIEF VALVE

Technical drawing of the BM372 subplate. It includes a top view showing a grid of ports labeled P, T, and M, with dimensions for overall size (max. 1128 x max. 57.5) and individual port spacing. A side view shows the subplate's profile with a height of 70 and a 3/8" BSP connection. A detail view shows a port with a 1/4" BSP connection and an M5-6H screw. Another detail view shows a port with an M6-6H screw and a 1/2" BSP connection. A pressure relief valve (CMP 10) is also indicated.

Type	A	B	Weight(Kg)
BM372/2	160	148	4,9
BM372/3	210	198	6,4
BM372/4	260	248	7,9
BM372/5	310	298	9,4
BM372/6	360	348	10,9
BM372/7	410	398	12,4
BM372/8	460	448	13,9

Fixing screws M5x70 UNI 5931



# BS5... SINGLE STATION SUBPLATE



## CETOP 5 SUBPLATES

BS501 / BS50	CAP. VII • 19
BS512... / BS513...	
BS514... / BS515...	CAP. VII • 20
BS516... / BS517...	
BS53...	CAP. VII • 21
BS530/31...	CAP. VII • 22
BSVMP20... / BS529...	CAP. VII • 23
BC536/28...	CAP. VII • 24
BC541/*... / BC540...	CAP. VII • 25
BC530/32... / BC550...	
BC551...	CAP. VII • 26
BC507... / BC5107...	
BC53A... / BC1006...	CAP. VII • 27
BM5**... / BM550...	CAP. VII • 28
BM560... / BM570...	
BM580...	CAP. VII • 29
CMP20...	CARTRIDGE CATALOGUE
CMP30...	CARTRIDGE CATALOGUE

## BS501...

- BS** Single subplate (blanking)
- 5** CETOP 5/NG10
- 01** P/T/A/B closed
- 00** No variant
- 1** Serial No.

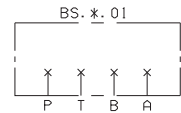

• Pay attention please, use these subplate in applications at slow pressure (P max. 150 bar dynamic)

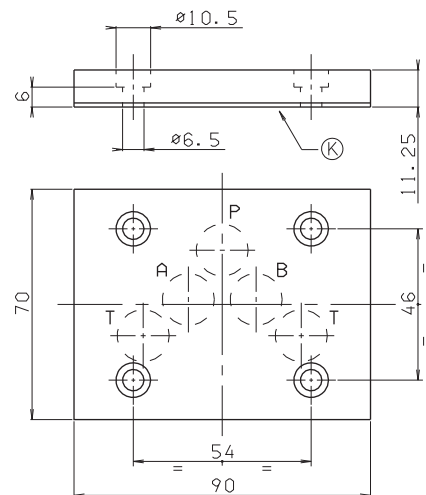

Weight: 0,5 Kg

Fixing screws  
M6x15 UNI 5931  
K = plate OR (Q25950002)

7

## BS5...

- BS** Single subplate (blanking)
- 5** CETOP 5/NG10
- \*\*** 02/03/04/05/06/07/08/09
- 00** No variant
- 1** Serial No.

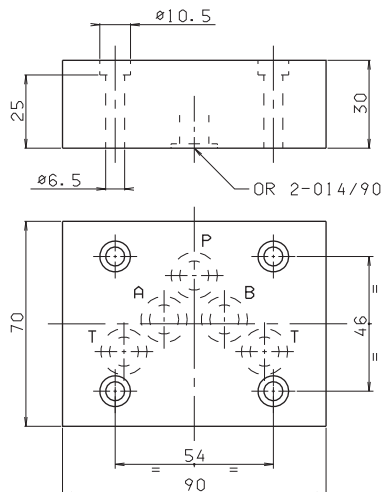

Weight: 1,2 Kg

Fixing screws M6x35 UNI 5931

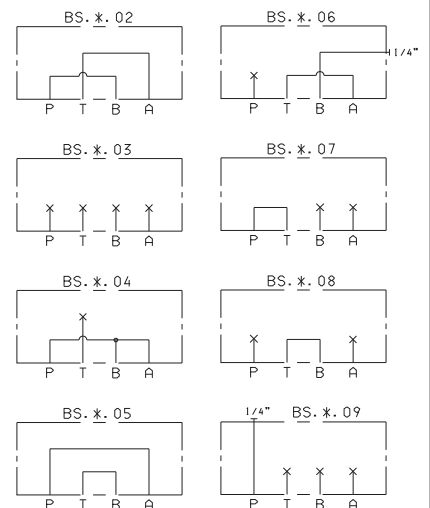

# BS5... SINGLE STATION SUBPLATE

## BS512 (REAR CONNECTORS)

- BS** Single subplate
- 5** CETOP 5/NG10
- 12** 1/2" BSP rear connectors
- 00** No variant
- 1** Serial No.

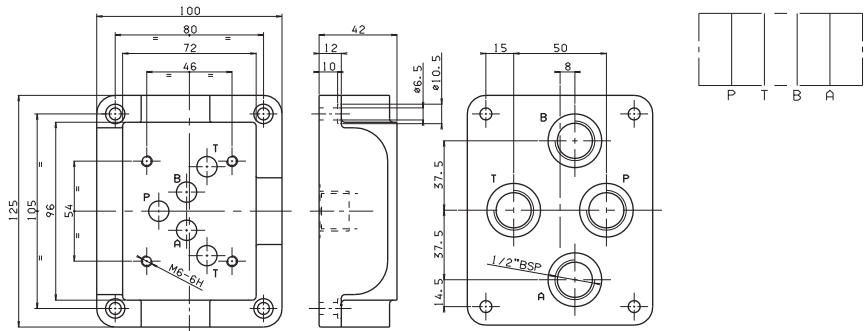

Weight: 2,7 Kg - Fixing screws M6x25 UNI 5931

## BS513 (REAR CONNECTORS)

- BS** Single subplate
- 5** CETOP 5/NG10
- 13** 3/4" BSP rear connectors
- 00** No variant
- 1** Serial No.

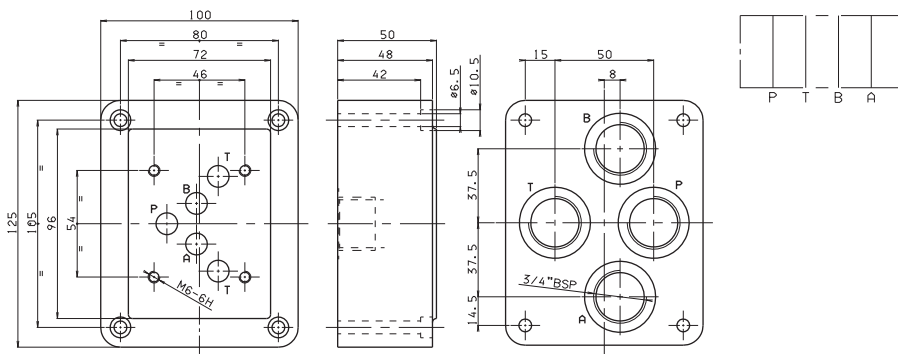

Weight: 3,8 Kg - Fixing screws M6x50 UNI 5931

7

## BS514 (SIDE CONNECTORS)

- BS** Single subplate
- 5** CETOP 5/NG10
- 14** 1/2" BSP side connectors
- 00** No variant
- 1** Serial No.

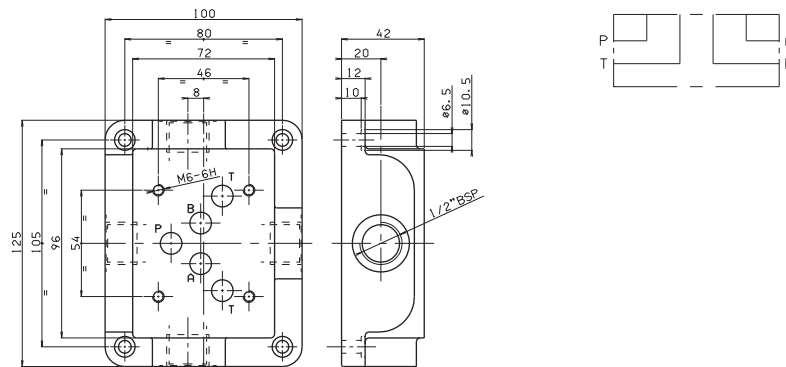

Weight: 2,6 Kg - Fixing screws M6x20 UNI 5931

## BS515 (SIDE CONNECTORS)

- BS** Single subplate
- 5** CETOP 5/NG10
- 15** 3/4" BSP side connectors
- 00** No variant
- 1** Serial No.

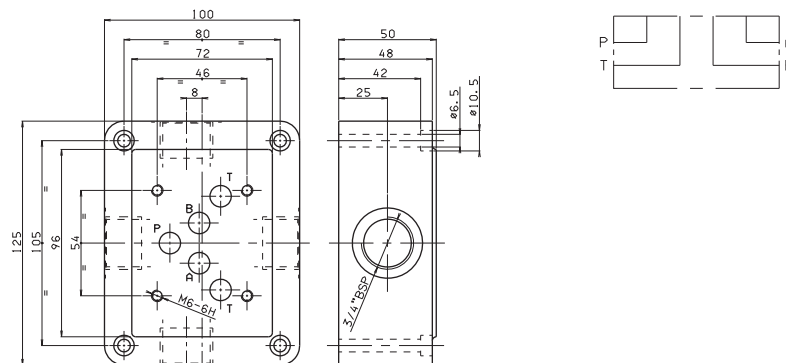

Weight: 3,8 Kg - Fixing screws M6x50 UNI 5931

# BS5... SINGLE STATION SUBPLATE

## BS516 (CONNECTORS SIDE A AND B, REAR P AND T)

- BS** Single subplate
- 5** CETOP 5/NG10
- 16** 1/2" BSP rear and side connectors
- 00** No variant
- 1** Serial No.

Weight: 2,6 Kg  
 Fixing screws M6x20 UNI 5931

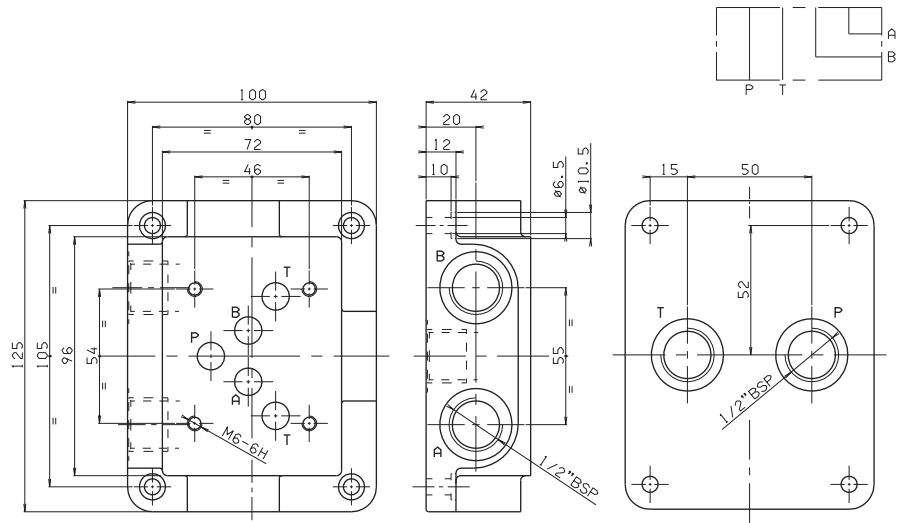

## BS517 (CONNECTORS SIDE A AND B, REAR P AND T)

- BS** Single subplate
- 5** CETOP 5/NG10
- 17** 3/4" BSP rear and side connectors
- 00** No variant
- 1** Serial No.

Weight: 3,9 Kg  
 Fixing screws M6x50 UNI 5931

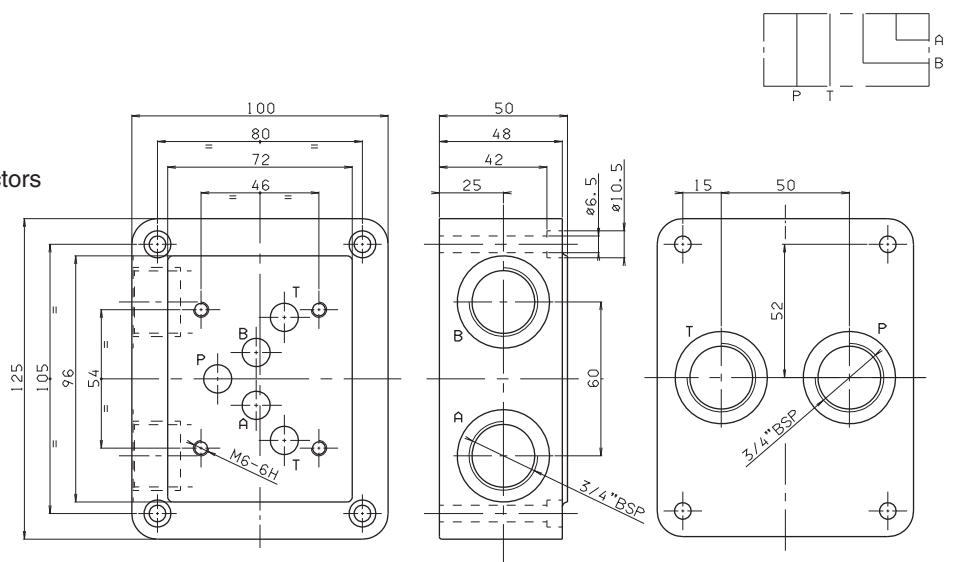

## BS53 (REDUCTION PLATE FROM CETOP 5/NG10 TO CETOP 3/NG6)

- BS** Single subplate
- 5** CETOP 5/NG10
- 3** CETOP 3/NG6
- 00** No variant
- 1** Serial No.

Weight: 1,1 Kg  
 Fixing screws M6x30 UNI 5931

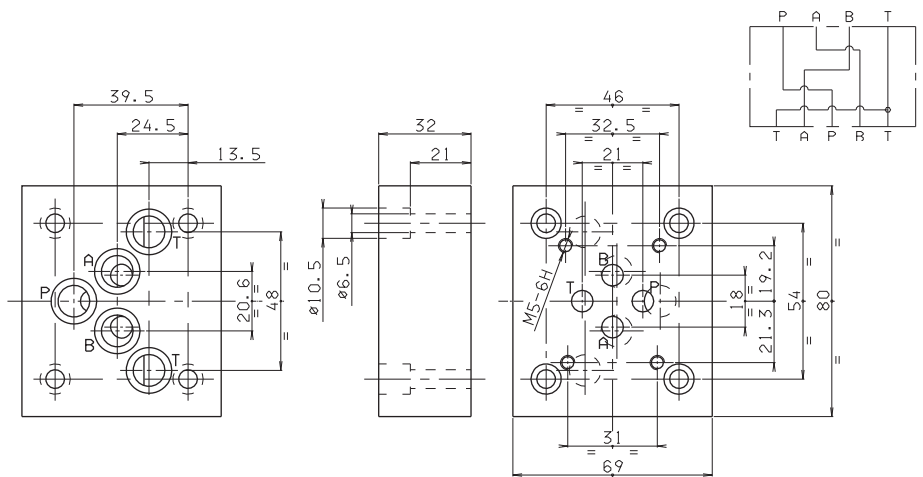

7

# BS5... SINGLE STATION SUBPLATE

## BS530/31

- BS** Single subplate
- 5** CETOP 5/NG10
- \*\*** **30** = Connectors A and B side, P and T rear (all 3/4" BSP)  
**31** = Connectors A and B side, P and T rear (all 3/4" BSP)
- \*** **M** = Plastic knob  
**C** = Grub screw
- \*** Setting range  
**1** = max. 50 bar (**white spring**)  
**2** = max. 140 bar (**yellow spring**)  
**3** = max. 350 bar (**green spring**)
- 00** No variant
- 1** Serial No.

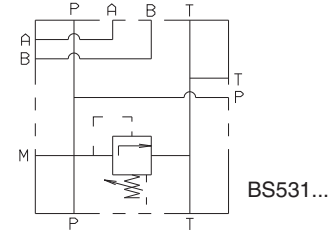
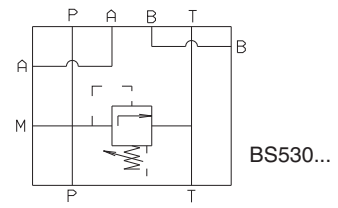

• The minimum permissible setting pressure depending on the spring:  
see cartridge valve type CMP30...

## BS530 (CONNECTORS A AND B SIDE, P AND T REAR)

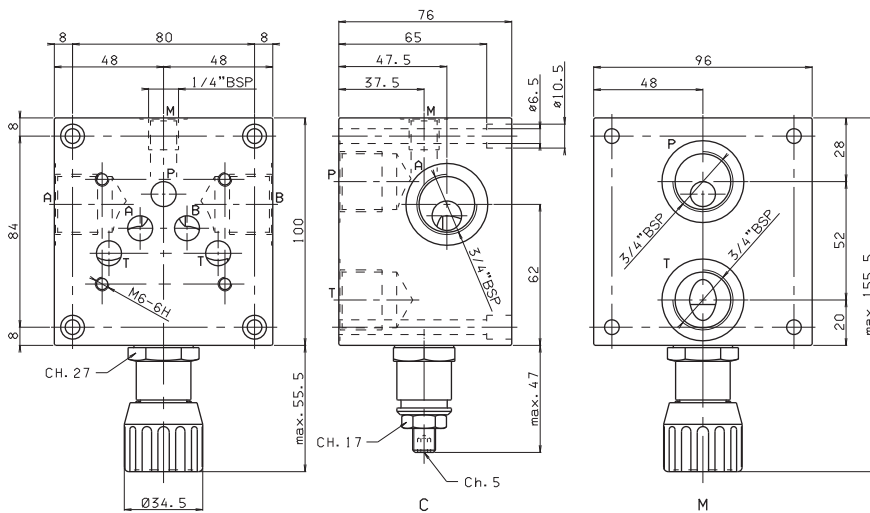

## BS5.1 (CONNECTORS A AND B SIDE, P AND T SIDE AND REAR)

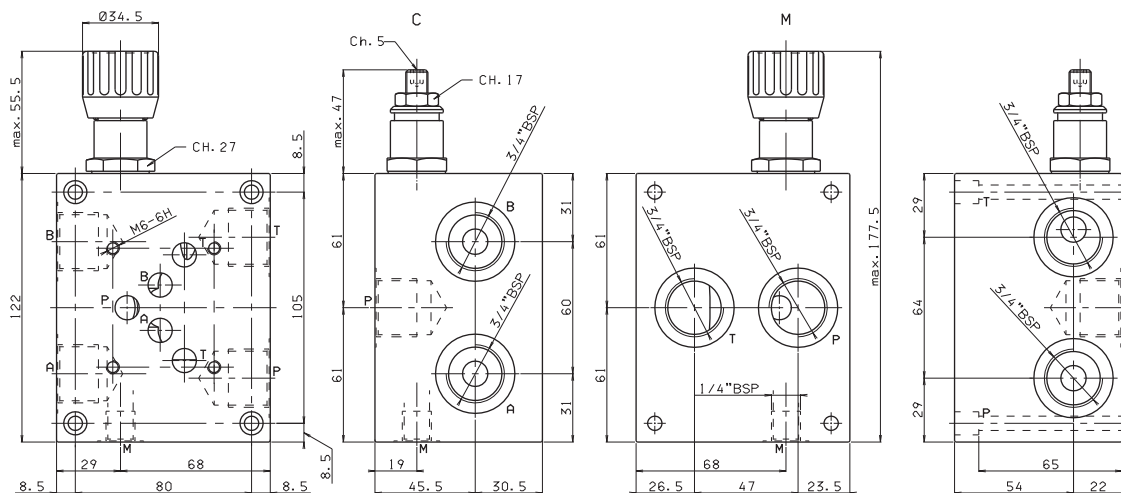

# BS5... SINGLE STATION SUBPLATE

## BSVMP20 SINGLE STATION SUBPLATE WITH MAX. PRESSURE VALVE FOR SURFACE MOUNTING (E.G. ON TANK COVER)

- BS** Single subplate
- VMP** Max. pressure valve
- 20** 1/2" BSP connectors
- \*** **M** = Plastic knob  
**C** = Grub screw  
**V** = Handwheel
- \*** Setting range  
**1** = max. 30 bar (**white spring**)  
**2** = max. 140 bar (**yellow spring**)  
**3** = max. 250 bar (**green spring**)
- 00** No variant
- 1** Serial No.

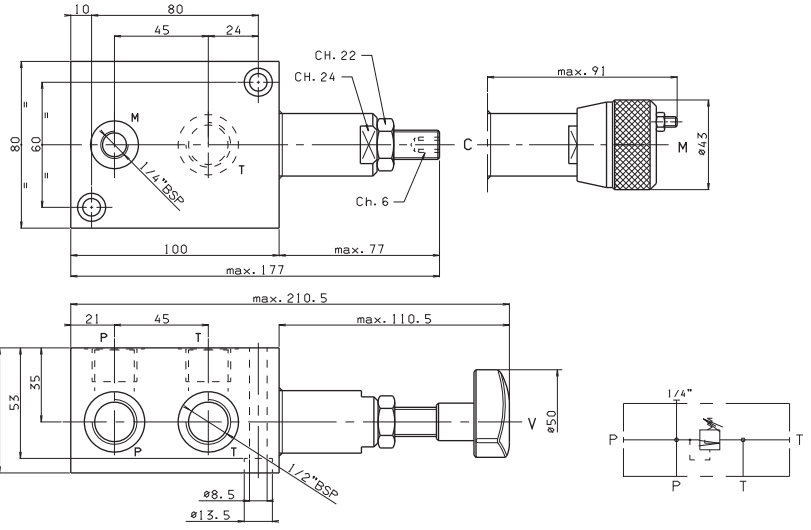

Weight: 3,1 Kg  
Fixing screws M8x65 UNI 5931

• The minimum permissible setting pressure depending on the spring: see cartridge valve type CMP20...

## BS529 SINGLE STATION SUBPLATE WITH MAX. PRESSURE VALVE FOR AD5I...

- BS** Single subplate
- 5** CETOP 5/NG10
- 29** 1/2" BSP - P rear connector  
1/2" BSP - A and B side connectors  
1/2" BSP - T rear connector  
3/4" BSP - T side connector
- C** Type of adjustment  
Grub screw
- \*** Setting range  
**2** = max. 150 bar (**yellow spring**)  
**3** = max. 320 bar (**green spring**)
- 00** No variant
- 1** Serial No.

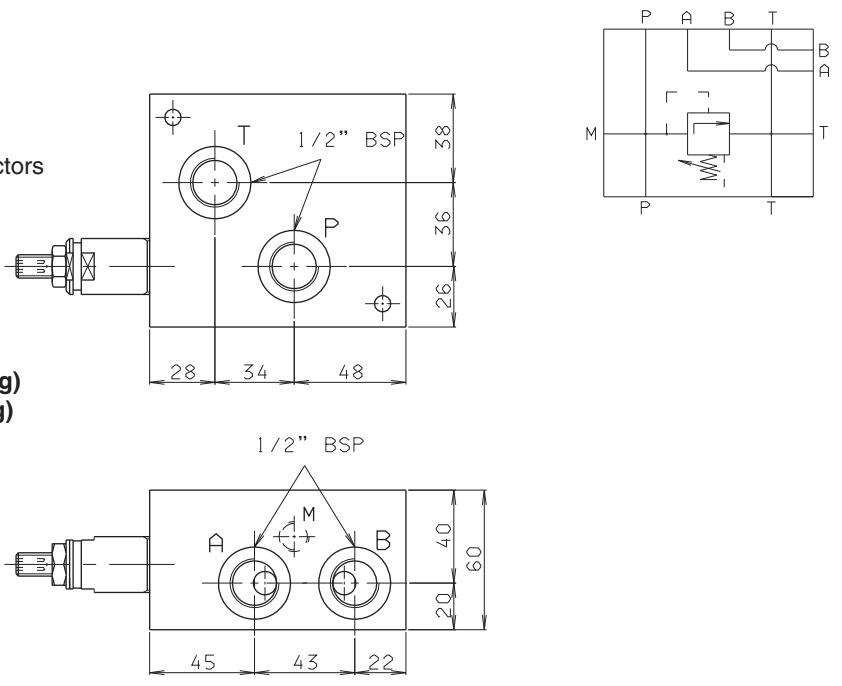

Weight: 4,5 Kg  
Fixing screws M6x60 UNI 5931

Tightening torque CMP.10...  
60 ÷ 70 Nm / 6 ÷ 7 Kgm

**M** = Manometer connector (1/4" BSP)

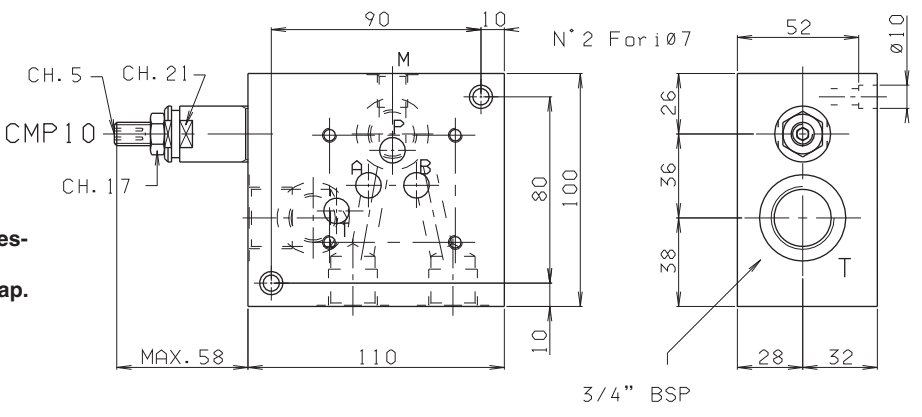

• The minimum permissible setting pressure depending on the spring: see cartridge valve type CMP10... Cap. VII • 30

7

# BC5... MODULAR COMPONENTS

## BC536/28 P AND T REAR AND SIDE CONNECTORS 3/4" BSP

- BC** Module base
- 5** CETOP 5/NG10
- \*\*** **36** = 3/4" BSP (P and T rear and side connectors with pressure relief valve)  
**28** = 3/4" BSP (P and T rear and side connectors without pressure relief valve)
- \*** Type adjustment (omit for 28 version)  
**M** = Plastic knob  
**C** = Grub screw
- \*** Setting range (omit for 28 version)  
**1** = max. 50 bar (**white spring**)  
**2** = max. 140 bar (**yellow spring**)  
**3** = max. 350 bar (**green spring**)
- 00** No variant
- 1** Serial No.

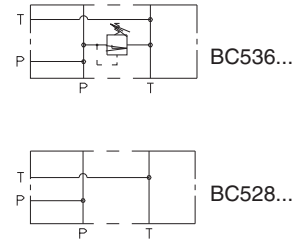

•The minimum permissible setting pressure valve is the same for all spring: see cartridge valve type CMP30...

## BC536 P/T REAR AND SIDE CONNECTORS WITH PRESSURE RELIEF VALVE

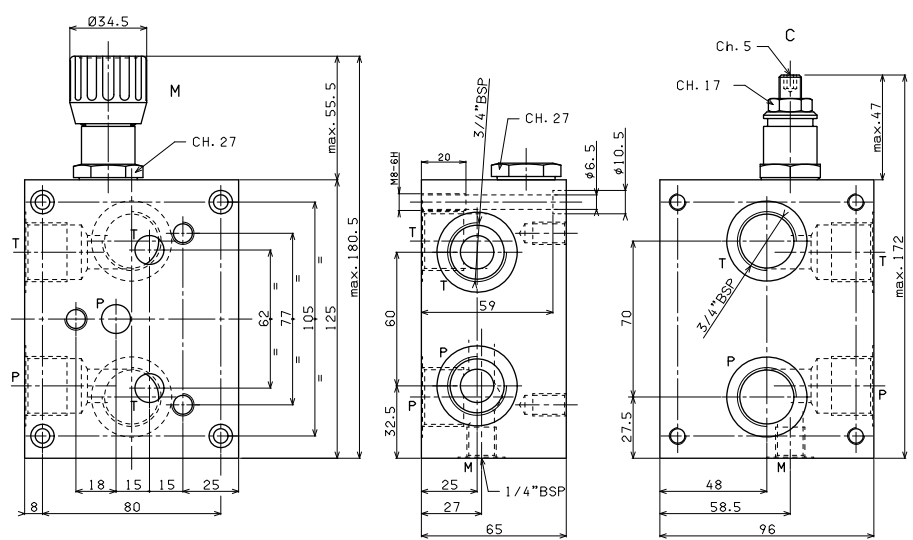

Weight: 5,3 Kg  
Fixing screws M6x70 UNI 5931

## BC528 P/T REAR AND SIDE CONNECTORS WITHOUT PRESSURE RELIEF VALVE

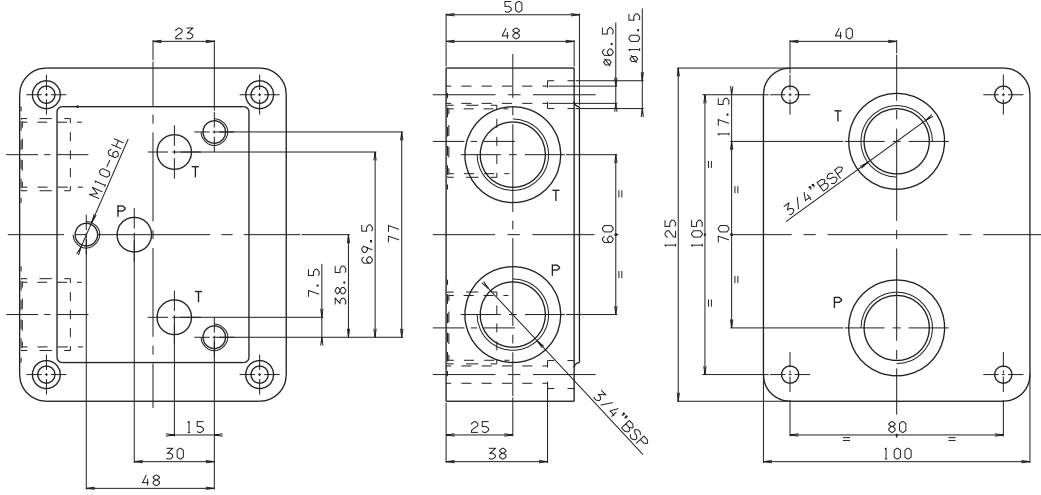

Weight: 3,9 Kg  
Fixing screws M6x50 UNI 5931

7

# BC5... MODULAR COMPONENTS

## ASSEMBLED BASE MODULES - 3 RODS

Rods code	L	Composition
BC541/2	M80250001	205 BC536/28+ 2 BC530/32 + BC540
BC541/3	M80250002	280 BC536/28+ 3 BC530/32 + BC540
BC541/4	M80250003	355 BC536/28+ 4 BC530/32 + BC540
BC541/5	M80250004	430 BC536/28+ 5 BC530/32 + BC540
BC541/6	M80250005	505 BC536/28+ 6 BC530/32 + BC540
BC541/7	M80250006	580 BC536/28+ 7 BC530/32 + BC540
BC541/8	M80250007	655 BC536/28+ 8 BC530/32 + BC540

<b>Nuts code</b>	Q26560545
<b>Pieces</b>	3

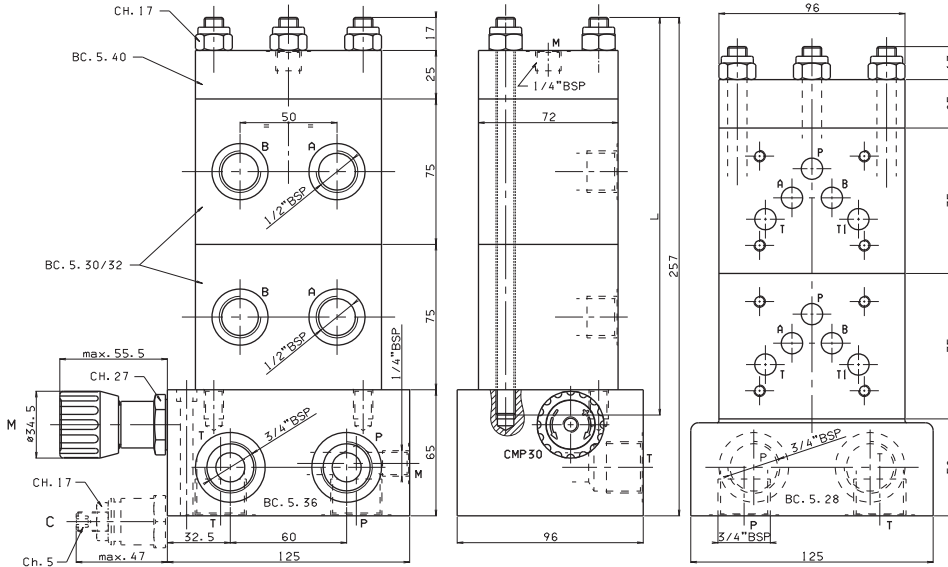
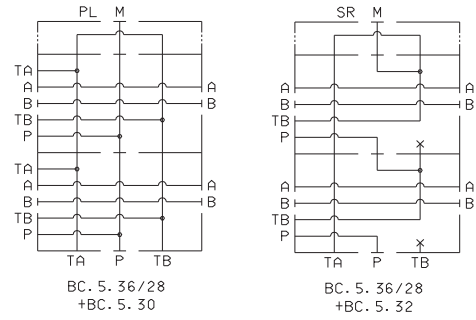

- Single components should be ordered separately
- The minimum permissible setting pressure is the same for all spring: see cartridge valve type CMP30...

## BC541/\* RODS FOR MODULAR ASSEMBLIES

Rods code	Pieces	L	Composition
BC541/2001	3	205	for 2 solenoid valve
BC541/3001	3	280	for 3 solenoid valve
BC541/4001	3	355	for 4 solenoid valve
BC541/5001	3	430	for 5 solenoid valve
BC541/6001	3	505	for 6 solenoid valve
BC541/7001	3	580	for 7 solenoid valve
BC541/8001	3	655	for 8 solenoid valve

Tightening torque: 47 Nm (±2 Nm)

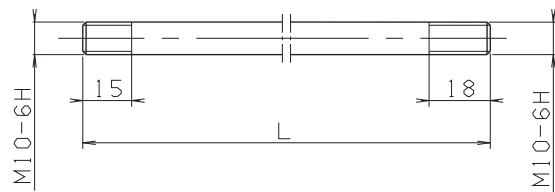

## BC540...

- BC** Module base
- 5** CETOP 5/NG10 - 3 rods
- 40** Blanking
- 00** No variant
- 1** Serial No.

Weight: 1 Kg

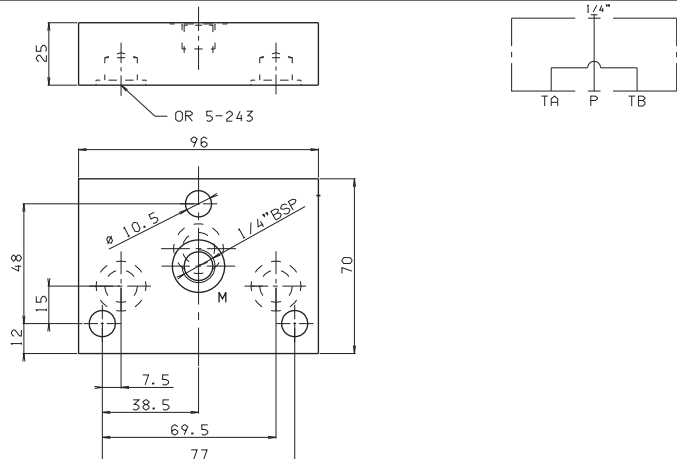

# BC5... MODULAR COMPONENTS

## BC530/32

- BC** Module base
- 5** CETOP 5/NG10 - 3 rods
- \*\***
  - 30** = 1/2" BSP connectors in parallel
  - 31** = 3/4" BSP connectors in parallel
  - 32** = 1/2" BSP connectors in series
- \*\***
  - 00** = No variant
  - AI** = A and B rear connector
  - AS** = A and B upper connectors
- 1** Serial No.

Weight: 3 Kg

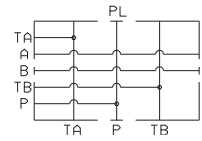
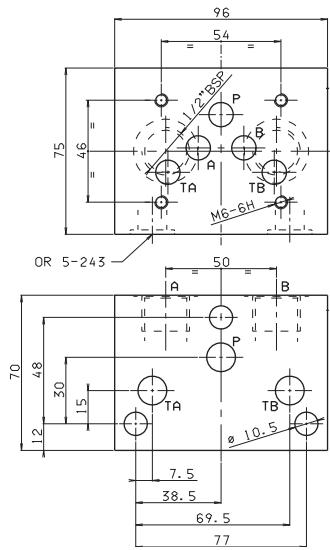

BC530...  
BC531...

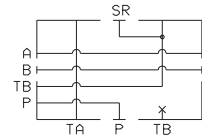

BC.5.32...

## BC550 INTERMEDIATE MODULE FOR PRESSURE GAUGE

- BC** Module base
- 5** CETOP 5/NG10
- 50** Intermediate module for pressure gauge connection at ports A/B/P/T
- 00** No variant
- 1** Serial No.

Weight: 2,3 Kg

K = plate OR (Q25950002)

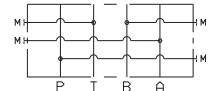
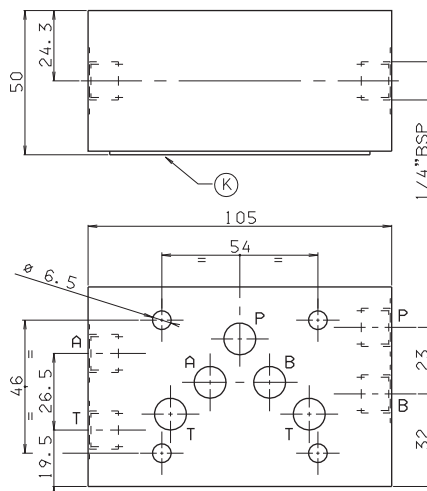

## BC551 DOWEL PLATE FOR SOLENOID VALVE

- BC** Module base
- 5** CETOP 5/NG10
- 51** Subplate for solenoid valve
- 00** No variant
- 1** Serial No.

Weight: 0,5 Kg

K = plate OR (Q25950002)

CALIBRATED DIAPHRAGMS AVAILABLE	
d	M8x1x8
0.6	M89100007
0.7	M89100008
0.8	M89100009
0.9	M89100012
1	M89100010
1.2	M89100011
1.4	M89100038
1.5	M89100035
1.75	M89100042
2	M89100041
2.5	M89100036

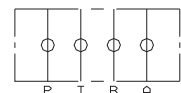
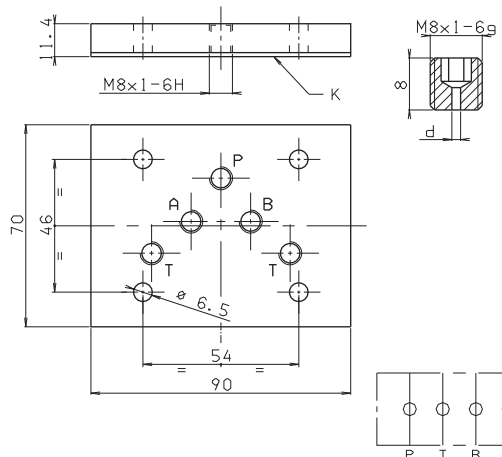



# BC5... MODULAR COMPONENTS

## BC507 BASE FOR DOUBLE FLOW RATE P→A E B→T

- BC** Module base
- 5** CETOP 5/NG10
- 07** Base for double flow rate
- 00** No variant
- 1** Serial No.

Weight: 1,2 Kg

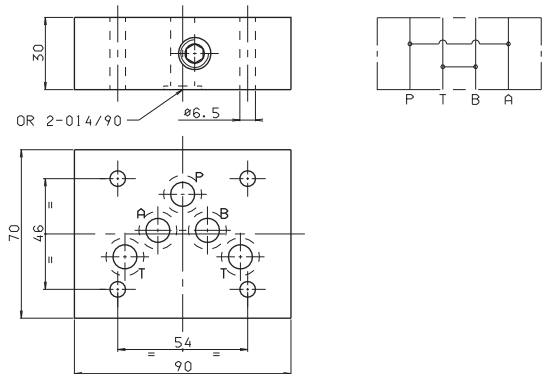

## BC5107 BASE FOR USE WITH 2 WAY VALVE

- BC** Module base
- 5** CETOP 5/NG10
- 107** Base for use with 2 way valve
- 00** No variant
- 1** Serial No.

Weight: 1,2 Kg

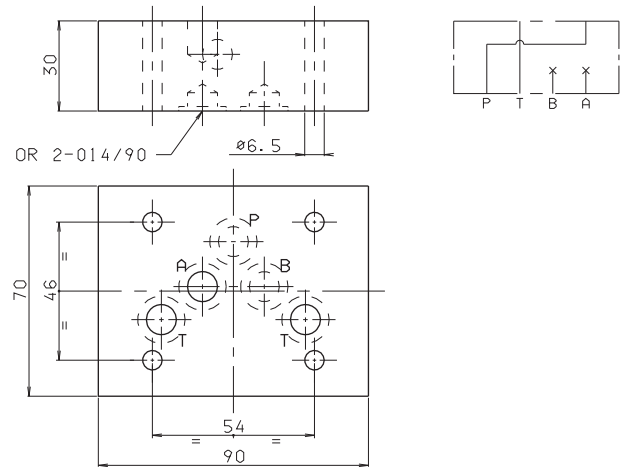

## BC53A REDUCTION BASE FROM BC5... TO BC3...

- BC** Module base
- 5** CETOP 5/NG10 - 3 rods
- 3A** CETOP 3/NG6 - 3 rods
- 00** No variant
- 1** Serial No.

Weight: 2,4 Kg - Fixing screws M10x30 UNI 5931

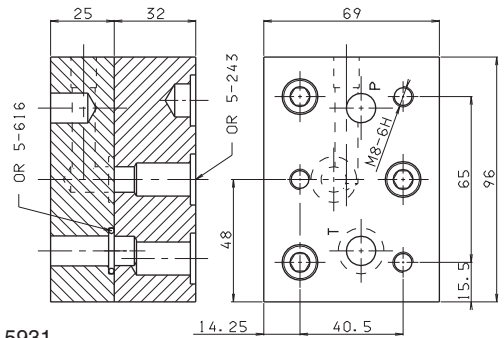

## BC1006 REDUCTION BASE FROM BC5... TO BC06...

- BC** Module base
- 10** CETOP 5/NG10 - 3 rods
- 06** CETOP 3/NG6 - 2 rods
- 00** No variant
- 1** Serial No.

Weight: 1,3 Kg - Fixing screws M10x30 UNI 5931

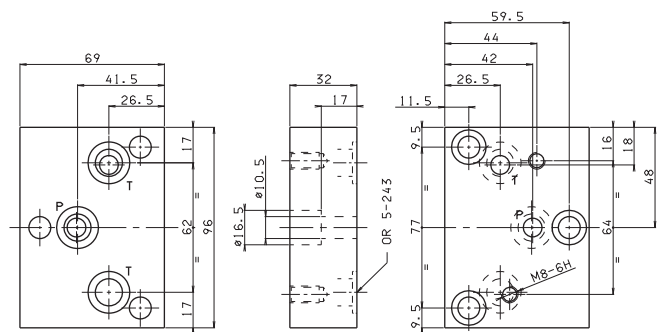

7

# BM5... MULTI STATION SUBPLATES

## BM5...

- BM** Multi station subplate (standard versions are supplied in cast iron material)
- 5** CETOP 5/NG10
- \*\***
  - 50** = Connected in parallel with pressure relief valve and rear connectors
  - 60** = Connected in parallel without pressure relief valve and side connectors
  - 70** = Connected in parallel with pressure relief valve and 3/4" BSP P/T connectors and 1/2" BSP side A/B
  - 80** = Connected in parallel with pressure relief valve and 1" BSP P/T connectors and 3/4" BSP side A/B
- \*** No. of valves seats (for BM580... max 6)  
**2 / 3 / 4 / 5 / 6 / 7 / 8**
- \*** Type of adjustment (omit for 60 version)  
**M** = Plastic knob  
**C** = Grub screw
- \*** Setting range (omit for 60 version)  
**1** = max. 50 bar (**white spring**)  
**2** = max. 140 bar (**yellow spring**)  
**3** = max. 350 bar (**green spring**)
- \*\*** **00** = No variant  
**AL** = in aluminium material (only for BM560 and BM570 versions), recommended pressure max. 230 bar
- 1** Serial No.

• The minimum permissible setting pressure is the same for all spring: see cartridge valve type CMP30...

## BM550 CONNECTED IN PARALLEL WITH PRESSURE RELIEF VALVE

7

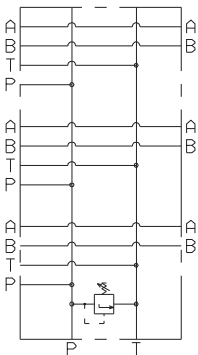

Type	A	B	Weight(Kg)
BM550/2	216	200	8,5
BM550/3	291	275	11,3
BM550/4	366	350	14
BM550/5	441	425	16,8
BM550/6	516	500	19,5
BM550/7	591	575	22,3
BM550/8	666	650	25

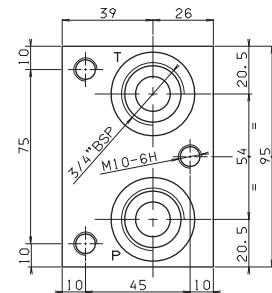
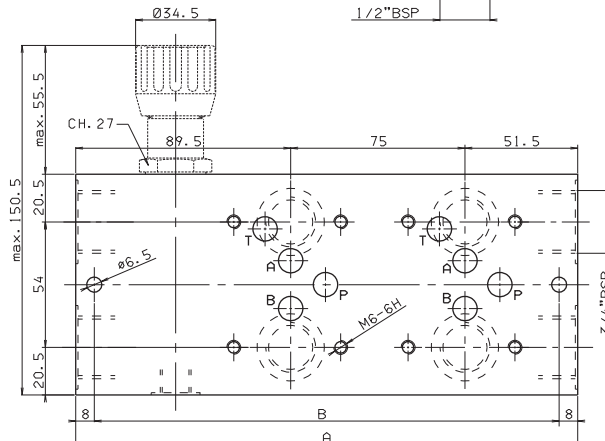
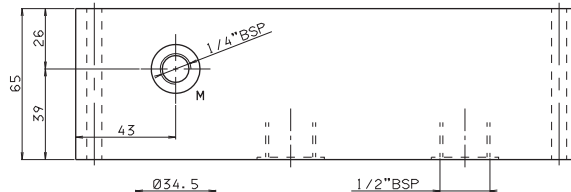
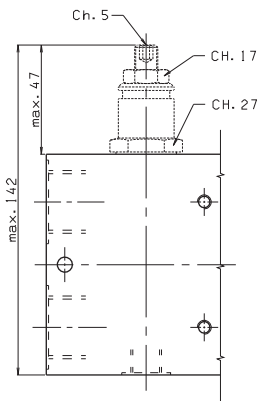

Fixing screws M6x75 UNI 5931

# BM5... MULTI STATION SUBPLATES

## BM560 CONNECTED IN PARALLEL WITHOUT PRESSURE RELIEF VALVE

Type	A	B	Weight(Kg)
BM560/2	175	159	10
BM560/3	250	234	14,2
BM560/4	325	309	18,4
BM560/5	400	384	22,6
BM560/6	475	459	26,8
BM560/7	550	534	31
BM560/8	625	609	35,2

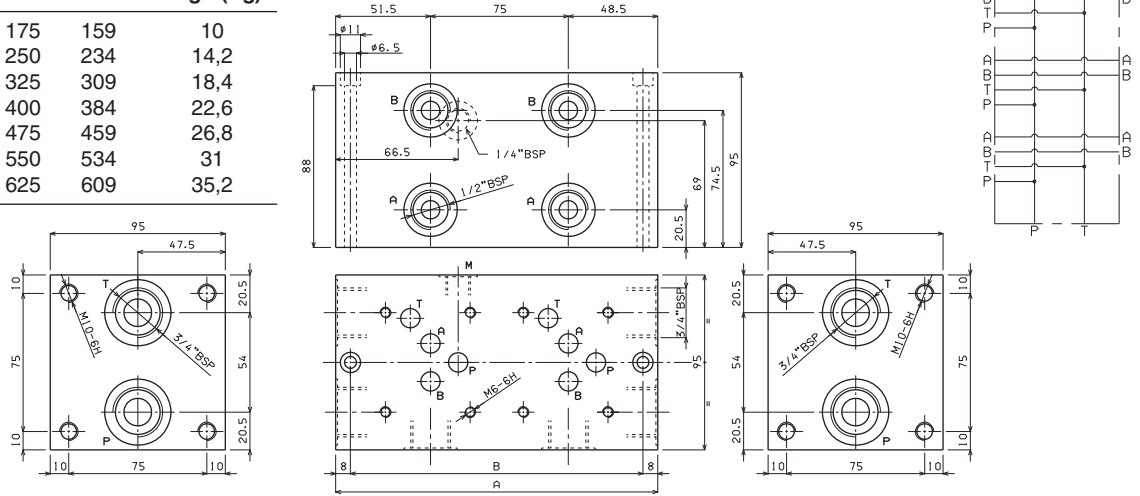

Fixing screws M6x100 UNI 5931

## BM570 CONNECTED IN PARALLEL WITH PRESSURE RELIEF VALVE

Type	A	B	Weight(Kg)
BM570/2	216	200	12,7
BM570/3	291	275	16,8
BM570/4	366	350	21
BM570/5	441	425	25,2
BM570/6	516	500	29,5
BM570/7	591	575	33,6
BM570/8	666	650	37,8

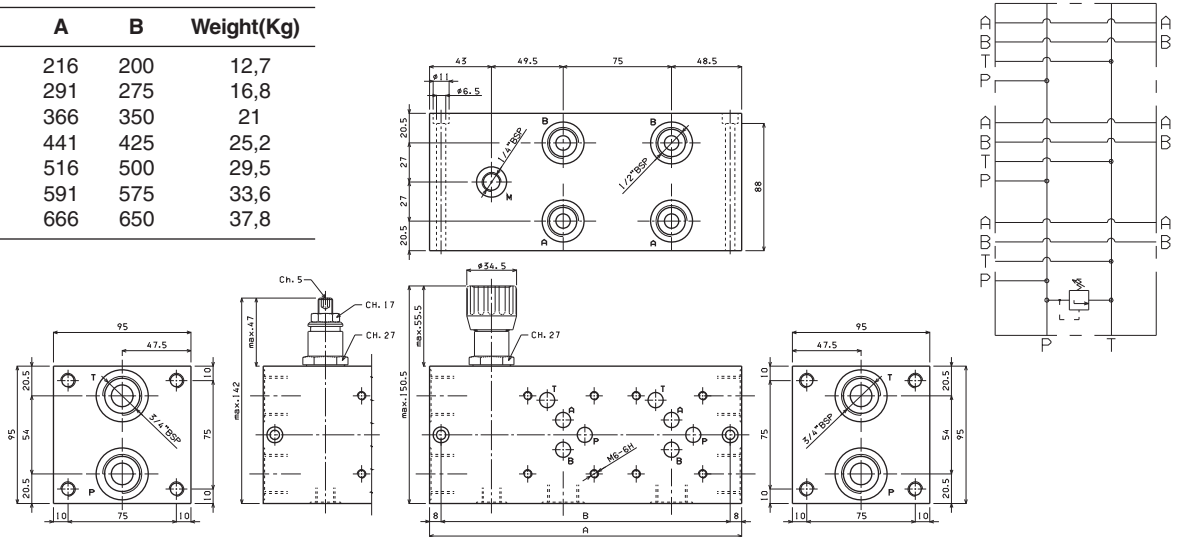

Fixing screws M6x100 UNI 5931

## BM580 CONNECTED IN PARALLEL WITH PRESSURE RELIEF VALVE

Type	A	B	Weight(Kg)
BM.5.80/2	225	205	19,5
BM.5.80/3	300	280	26
BM.5.80/4	375	355	32,5
BM.5.80/5	450	430	39
BM.5.80/6	525	505	45,5

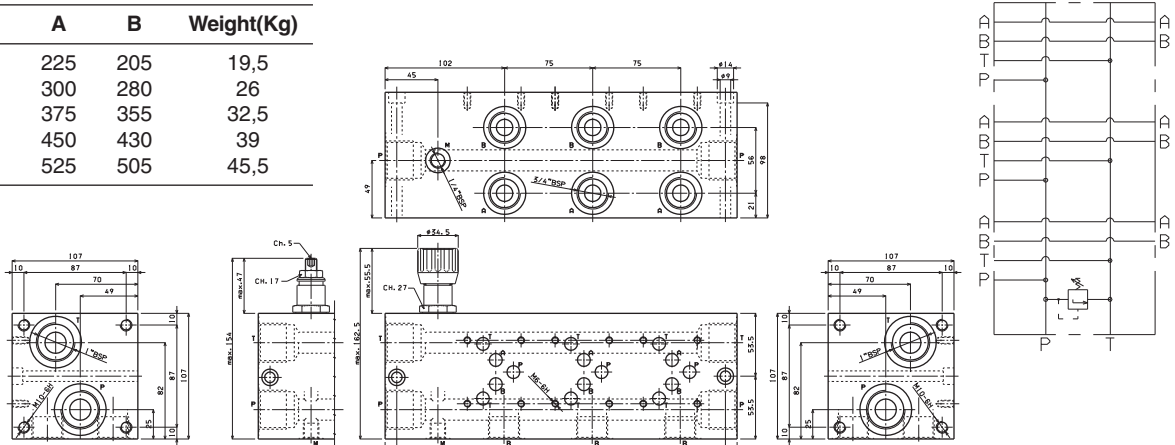

Fixing screws M8x110 UNI 5931



# CMP10... DIRECT OPERATION MAXIMUM PRESSURE VALVES



CMP10...

The direct acting relief valve limits the pressure in a hydraulic circuit. It raises the safety level by making it impossible for the plant operators to set a higher pressure rating, than that specified in the catalogue. This is limited by a pack spring with a mechanical stop, which prevents temporary P closures caused by pressure peaks. It has a galvanised steel body. The guided ball poppet is in tempered and ground steel.

Max. operating pressure	320 bar
Setting ranges:	Spring 0 max. 15 bar
	Spring 1 max. 50 bar
	Spring 2 max. 150 bar
	Spring 3 max. 320 bar
Max. flow	40 l/min
Hydraulic fluids	Mineral oils DIN 51524
Fluid viscosity	10 ÷ 500 mm <sup>2</sup> /s
Fluid temperature	-25°C ÷ 75°C
Ambient temperature	-25°C ÷ 60°C
Max. contamination level	class 10 in accordance with NAS 1638 with filter β <sub>25</sub> ≥ 75
Weight	0,2 Kg
Tightening torque	60 ÷ 70 Nm (6 ÷ 7 Kgm)
• The minimum permissible setting pressure depending on the screw: see curves below	

## ORDERING CODE

<b>CMP</b>	Max. pressure cartridge
<b>10</b>	Size (M24 x 2)
<b>*</b>	Type of adjustment M = Plastic knob C = Grub screw V = Handwheel
<b>*</b>	Setting ranges 0 = max. 15 bar (orange spring) 1 = max. 50 bar (white spring) 2 = max. 150 bar (yellow spring) 3 = max. 320 bar (green spring)
<b>**</b>	00 = No variant V1 = Viton
<b>2</b>	Serial No.

## HYDRAULIC SYMBOL

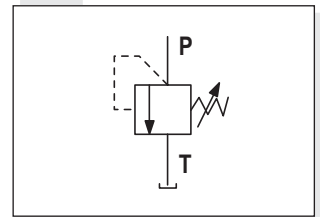

## PRESSURE-FLOW RATE

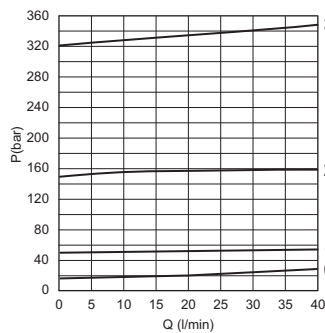

## MIN. SETTING PRESSURE

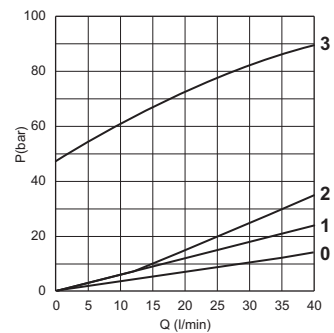

0 = CMP100.. - 1 = CMP101.. - 2 = CMP102.. - 3 = CMP103..  
Fluid used: mineral based oil with viscosity 32 mm<sup>2</sup>/s at 40°C.

## OVERALL DIMENSIONS

Type of adjustment		<h3>SEAT DIMENSIONS</h3>
M Plastic knob		
C Grub screw		
V Handwheel		<p>Valve seat plug code <b>R78300564</b></p>
<p><b>00012008</b> Spare seals kit</p>		

## ABBREVIATIONS

<b>AP</b>	HIGH PRESSURE CONNECTION
<b>AS</b>	PHASE LAG (DEGREES)
<b>BP</b>	LOW PRESSURE CONNECTION
<b>C</b>	STROKE (MM)
<b>CH</b>	ACROSS FLATS
<b>Ch</b>	INTERNAL ACROSS FLATS
<b>DA</b>	AMPLITUDE DECAY (dB)
<b>DP</b>	DIFFERENTIAL PRESSURE (BAR)
<b>F</b>	FORCE (N)
<b>I%</b>	INPUT CURRENT (A)
<b>M</b>	MANOMETER CONNECTION
<b>NG</b>	KNOB TURNS
<b>OR</b>	SEAL RING
<b>P</b>	LOAD PRESSURE (BAR)
<b>PARBAK</b>	PARBAK RING
<b>PL</b>	PARALLEL CONNECTION
<b>Pr</b>	REDUCED PRESSURE (BAR)
<b>Q</b>	FLOW (L/MIN)
<b>QP</b>	PUMP FLOW (L/MIN)
<b>SE</b>	ELASTIC PIN
<b>SF</b>	BALL
<b>SR</b>	SERIES CONNECTION
<b>X</b>	PILOTING
<b>Y</b>	DRAINAGE

## PROPORTIONAL VALVES



XD2A... / XD2C...	CAP. VIII • 2
XD3A... / XD3C...	CAP. VIII • 4
D15P PROPORTIONAL SOLENOIDS	CAP. VIII • 5
XDP3A... / XDP3C ...	CAP. VIII • 6
D15P PROPORTIONAL SOLENOIDS	CAP. VIII • 7
XDP5A... / XDP5C...	CAP. VIII • 8
D19P PROPORTIONAL SOLENOIDS	CAP. VIII • 9
XDC3... SERIE 2	CAP. VIII • 10
PROPORTIONAL SOLENOIDS XDC3	CAP. VIII • 11
XEPV3...	CAP. VIII • 12
AM3H...	CAP. VIII • 15
AM5H...	CAP. VIII • 16
XQ3...	CAP. VIII • 17
D15P PROPORTIONAL SOLENOIDS	CAP. VIII • 18
XQP3.	CAP. VIII • 19
D15P PROPORTIONAL SOLENOIDS	CAP. VIII • 20
XQP5.	CAP. VIII • 21
D15P PROPORTIONAL SOLENOIDS	CAP. VIII • 22
XP3...	CAP. VIII • 23
AM3XMP...	CAP. VIII • 25

## XD2A... / XD2C... SOLENOID OPERATING PROPORTIONAL VALVES CETOP 2



XD2A../XD2C.. series valves are used for controlling fluid direction and flow rate as a function of the supply current to the proportional control solenoid.

Any valve  $\Delta p$  variation causes a change in the set flow rate; however the valve itself ensure a high level internal compensation maintaining constant a regulated flow..

The XD2 cetop valve could be used for accurate proportional controls with compact sizes, reducing weights.

These valves can be also combined with Mini Powerpacks type MR/MC/FP creating compact solutions. Could be also used on a Cetop 3 interface using a reduction plate type BS32001.

XD2...	
STANDARD CONNECTORS	CAP. I • 20
DC SOLENOID A09	CAP. I • 4
REMSRA...	CAP. IX • 4
REMDRA...	CAP. IX • 7
CEPS	CAP. IX • 2
AM3H...	CAP. VIII • 15
BS32001	CAP. VII • 3

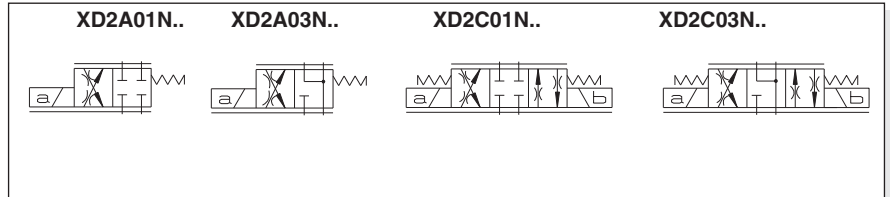

### ORDERING CODE

<b>XD</b>	Proportional valve
<b>2</b>	CETOP 2/NG04
<b>*</b>	<b>A</b> = Single solenoid <b>C</b> = Double solenoid
<b>**</b>	Type of spool (null position)
	<b>01</b> = <b>03</b> =
<b>*</b>	Flow path control (see symbols table) <b>N</b> = symmetrical
<b>*</b>	Flow rating l/min ( $\Delta p$ 5 bar) <b>1</b> = 1.5 l/min <b>6</b> = 6 l/min
<b>*</b>	Max. spool current <b>F</b> = 1.4 A <b>G</b> = 0.7 A
<b>**</b>	Variant: see Tab.1
<b>1</b>	Serial No.

### TAB.1 - VARIANTS

No variant (without connectors)	S1(*)
Viton	SV(*)
AMP Junior connection	AJ(*)
Coil with flying leads (250 mm)	FL
Coil with flying leads (130 mm) with diode	LD
Deutsch connection with bidirectional diode	CX

(\*) Coils with Hirschmann and AMP Junior connection supplied without connectors. The connectors can be ordered separately, Cap. I • 20.

### INPUT SIGNAL CURVES - FLOW RATE

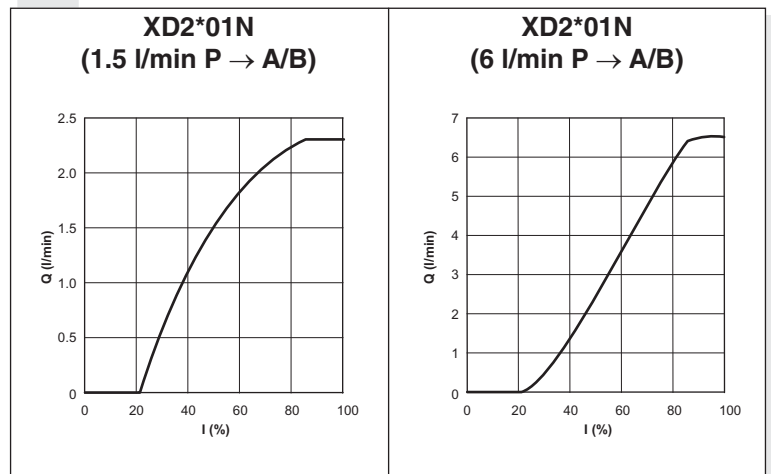

### POWER LIMITS TRANSMITTED

P → A/B → T    P → B/A → T

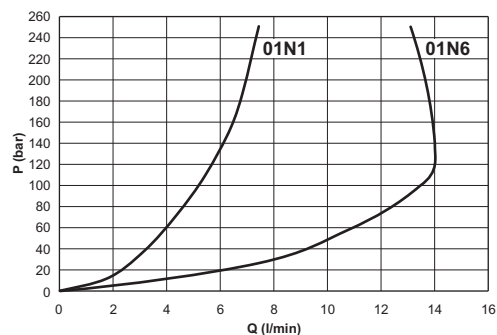

The fluid used was a mineral oil with a viscosity of 46 mm<sup>2</sup>/s at 40°C. The tests have been carried out at with a fluid of 40°C.

Performances shown in this catalogue are guaranteed only using a pressure compensator of 5 bar.

# XD2A... / XD2C... SOLENOID OPERATING PROPORTIONAL VALVES CETOP 2

## OPERATING SPECIFICATIONS

Max. operating pressure ports P/A/B	250 bar
Max. operating pressure ports T - for dynamic pressure see note (*)	250 bar
Regulated flow rate	1.5 / 6 l/min
Relative duty cycle	Continuous 100% ED
Type of protection	IP 65
Flow rate gain	See diagrams
Hysteresis with connection P/A/B/T $\Delta p = 5$ bar (P/A)	$\leq 13\%$ of max. flow rate
Fluid viscosity	$10 \div 500$ mm <sup>2</sup> /s
Fluid temperature	$-20^{\circ}\text{C} \div 75^{\circ}\text{C}$
Max. contamination level	class 8 in accordance with NAS 1638 with filter $\beta_{10} \geq 75$
Weight XD.2.A... (single solenoid)	0.88 Kg
Weight XD.2.C... (double solenoid)	1.1 Kg
Max. current (voltage)	1.4A (a 12V) 0.7A (a 24V)
Solenoid coil resistance at 25°C (77°F)	5.3 Ohm 21.3 Ohm

(\*) Pressure dynamic allowed for 500000 cycles

• Operating specifications are valid for fluid with 46 mm<sup>2</sup>/s viscosity at 40°C, using the specified electronic control units.

## ELECTRONIC CONTROL UNIT

### REMSRA\*\* and REMDRA\*\*

Card type control for single and double solenoid.  
Recommended dither frequency 100 Hz.

### CEPS

Electronic amplifier plug version  
for single solenoid proportional valve (150Hz  
PWM frequency setting)

## OVERALL DIMENSIONS

Manual emergency: if necessary, use a tool that does not damage the brass button.

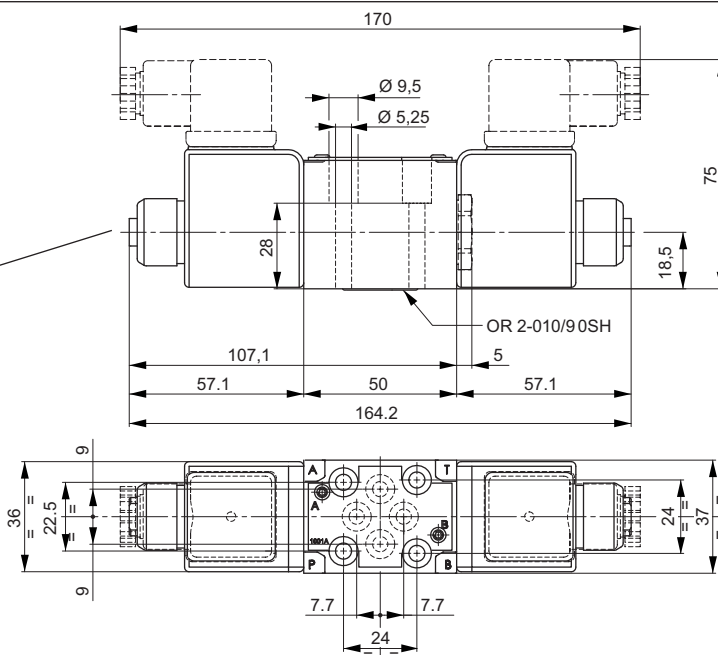

Fixing screws UNI 5931 M5x35 (min. 8.8 material screws are recommended)  
Tightening torque 5 Nm / 0.5 Kgm

8

## PROPORTIONAL SOLENOID

Type of protection (in relation to connector used)	IP 65
Number of cycle	18.000/h
Supply tolerance	$\pm 10\%$
Ambient temperature	$-30^{\circ}\text{C} \div 60^{\circ}\text{C}$
Duty cycle	100% ED
Insulation class wire	H
Weight	0,215 Kg



AMP JUNIOR (AJ)

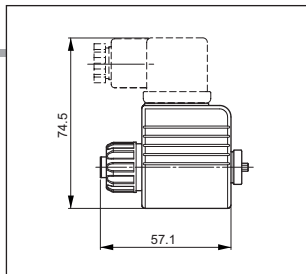
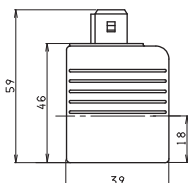

FLYING LEADS (FL)  
LEADS + DIODE (LD)

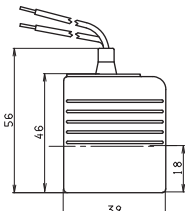

DEUTSCH COIL + BIDIR. DIODE (CX)  
DT04 - 2P

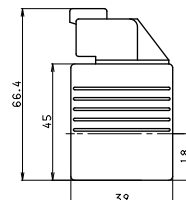

# XD3A... / XD3C... SOLENOID OPERATING PROPORTIONAL VALVES CETOP 3

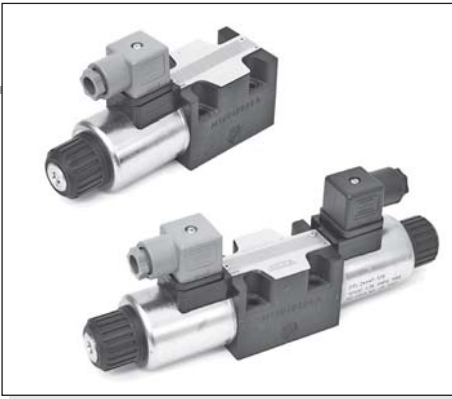

XD3A.../XD3C... series valves are used for controlling fluid direction and flow rate as a function of the supply current to the proportional solenoid.

Any valve  $\Delta p$  variation causes a change in the set flow rate; however the valve itself ensure a high level internal compensation by limiting the controlled flow rate.

To ensure a constant flow rate and reduce leakage, we recommend to use AM3H2V or AM3H3V hydrostats.

**Performances shown in this catalogue are guaranteed only using 2 or 3 way modular assembly hydrostats type AM3H. ...**

The shown flow rates are typical for one line operation (e.g. from P to B), while higher flow rates are obtainable by using the valve with our flow rate doubling sub-base type BC307 (see diagram next page). This type of configuration extends considerably the flow rate limit.

XD3...	
STANDARD CONNECTORS	CAP. I • 20
"D15P" PROPORT. SOLENOIDS	CAP. VIII • 5
REMSRA...	CAP. IX • 4
REMRA...	CAP. IX • 7
AM3H...	CAP. VIII • 15
BC307...	CAP. VII • 12

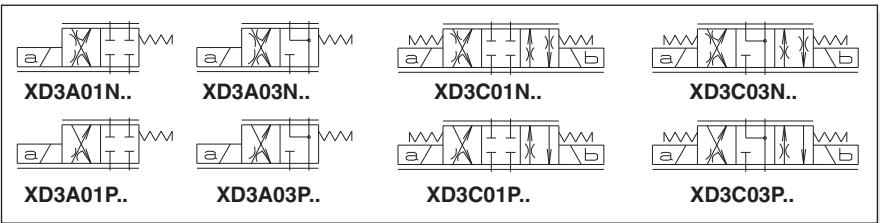

## ORDERING CODE

<b>XD</b>	Proportional valve
<b>3</b>	CETOP 3/NG06
<b>*</b>	<b>A</b> = Single solenoid <b>C</b> = Double solenoid
<b>**</b>	Type of spool (null position)
	<b>01</b> = <b>03</b> =
<b>*</b>	Flow path control (see symbols table) <b>N</b> = symmetrical <b>P</b> = meter in
<b>*</b>	Flow rating l/min ( $\Delta p$ 5 bar) <b>1</b> = 3 l/min <b>2</b> = 10 l/min <b>3</b> = 15 l/min <b>4</b> = 18 l/min
<b>*</b>	<b>E</b> = 2.35 A <b>F</b> = 1.76 A <b>G</b> = 0.88 A
<b>**</b>	Variant: see Tab.1
<b>2</b>	Serial No.

## TAB.1 - VARIANTS (\*)

No variant (without connectors)	S1
Viton	SV
Rotary emergency	P2
Rotary emergency 180°	R5

(\*) All variants are considered without connectors. The connectors must be order separately. See Cap. I • 20.

## INPUT SIGNAL CURVES - FLOW RATE

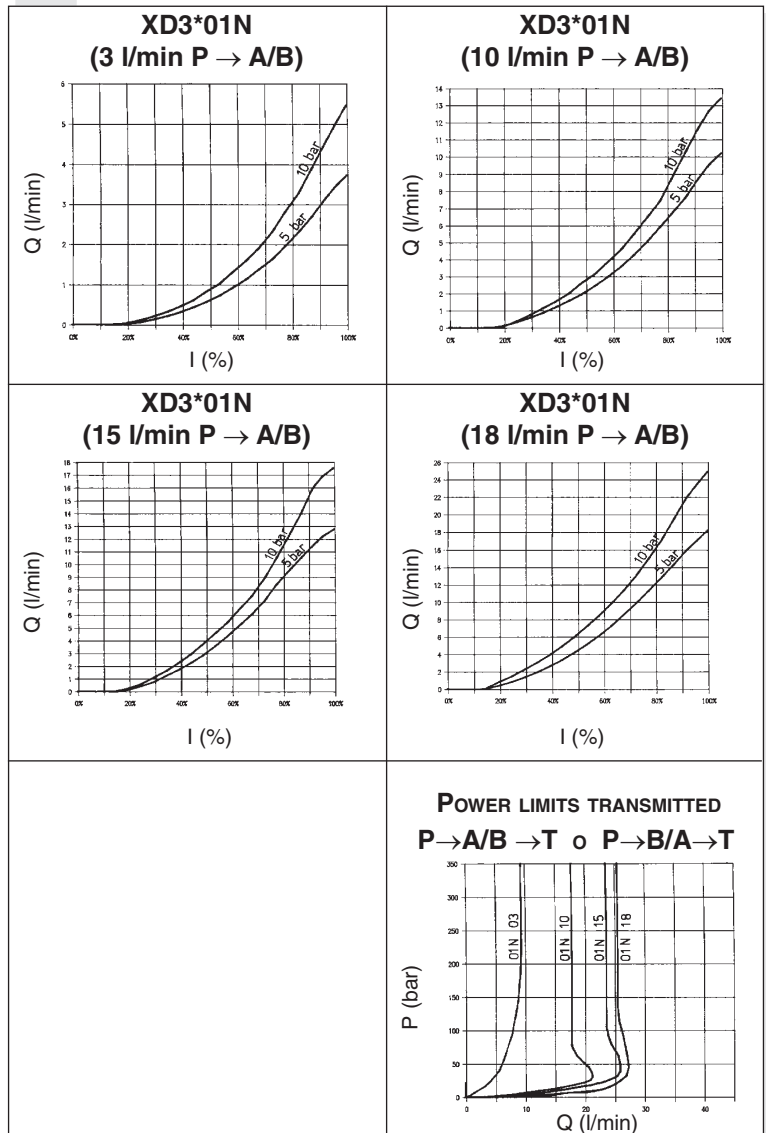

The fluid used is a mineral based oil with a viscosity of 46 mm<sup>2</sup>/s at 40°C. The tests have been carried out at with a fluid of a 40°C.



# XD3A... / XD3C... SOLENOID OPERATING PROPORTIONAL VALVES CETOP 3

## OPERATING SPECIFICATIONS

Max. operating pressure ports P/A/B	350 bar		
Max. operating pressure ports T - for dynamic pressure see note (*)	250 bar		
Regulated flow rate	3 / 10 / 15 / 18 l/min		
Relative duty cycle	Continuous 100% ED		
Type of protection	IP 65		
Flow rate gain	See diagrams		
Hysteresis with connection P/A/B/T $\Delta p = 5$ bar (P/A)	$\leq 7\%$ of max. flow rate		
Fluid viscosity	$10 \div 500$ mm <sup>2</sup> /s		
Fluid temperature	$-20^{\circ}\text{C} \div 75^{\circ}\text{C}$		
Max. contamination level	class 8 in accordance with NAS 1638 with filter $\beta_{10} \geq 75$		
Weight XD.3.A... (single solenoid)	1,5 Kg		
Weight XD.3.C... (double solenoid)	1,7 Kg		
Type of voltage	9V	12V	24V
Max. current	2.35A	1.76 A	0.88 A
Solenoid coil resistance at 25°C (77°F)	2.25 Ohm	4.0 Ohm	16.0 Ohm

(\*) Pressure dynamic allowed for 2 millions of cycles.

• Operating specifications are valid for fluid with 46 mm<sup>2</sup>/s viscosity at 40°C, using the specified electronic control units.

## ELECTRONIC CONTROL UNIT

### REMSRA\*\* and REMDRA\*\*

Card type control for single and double solenoid. Recommended dither frequency 100 Hz.

### AM3H2VP1 and AM3H3VP1

Hydrostats 2 or 3 way.

## SCHEMA FOR DOUBLE FLOW RATE

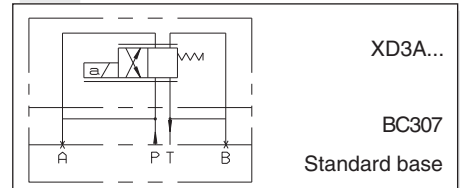

## XD3A... OVERALL DIMENSIONS

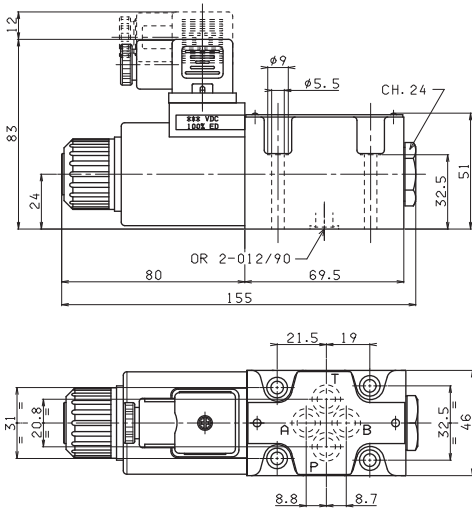

## XD3C... OVERALL DIMENSIONS

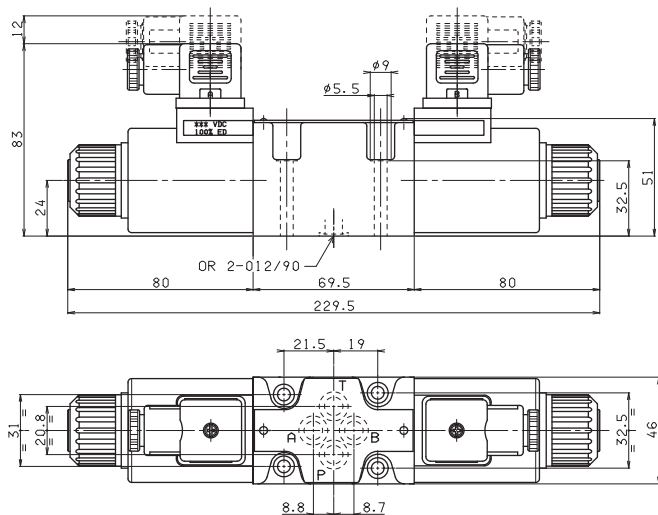

Fixing screws UNI 5931 M5x40 (min. 8.8 material screws are recommended)  
Tightening torque 4 ÷ 5 Nm / 0.4 ÷ 0.5 Kgm

Support plane specification

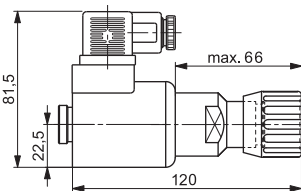
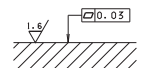

P2 Rotary emergency (1)

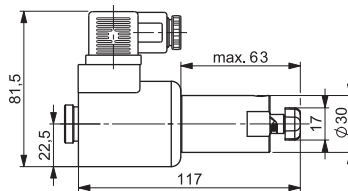

R5 Rotary emergency 180° (2)

- (1) P2 - Adjustable hand emergency.
- (2) R5 - Two positions hand emergency. The regulated flow with emergency actuated can be less than nominal value.

8

## "D15P" PROPORTIONAL SOLENOIDS

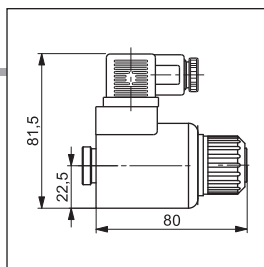

Type of protection (in relation to connector used)	IP 66
Duty cycle	100% ED
Insulation class wire	H
Weight (coil)	0,354 Kg
Weight (solenoid)	0,608 Kg

# XDP3A... / XDP3C ...

## PROPORTIONAL DIRECTIONAL VALVES OPEN LOOP



The open loop valves of series XDP... control the direction and the volume of the flow according to the feeding current to the proportional solenoid. By using a valve body equipped with increased passage channels it is possible to reach the highest capacity of its dimensions at a parity of pressure drops, (40 l/min with  $\Delta p$  of 10 bar).

Each  $\Delta p$  variation on the valve leads to the variation of the capacity which has been set, anyway the valve guarantees an high inner compensation grade and limits the adjustment capacity.

**Performances shown in this catalogue are guaranteed only using 2 or 3 way modular assembly hydrostats type AM3H. ...** By using the valve with the base for capacity doubling type BC307 (see next page) a greater capacity can be obtained.

### XDP3...

STANDARD CONNECTORS	CAP. I • 20
D15P PROPORTIONAL SOLENOIDS	CAP. VIII • 7
REMSRA...	CAP. IX • 4
REMDRA...	CAP. IX • 7
AM3H...	CAP. VIII • 15
AM5H...	CAP. VIII • 16
BC307...	CAP. VII • 12

### XDP3C01N...



### XDP3A01N...



### XDP3C03N...



### XDP3A03N...



### XDP3C01P...



### XDP3A01P...



### ORDERING CODE

**XDP**

Open loop proportional directional valve

**3**

CETOP 3/NG06

**\***

**A** = Single solenoid  
**C** = Double solenoid

**\*\***

Type of spool (null position)



**\***

Flow path control (see hydraulic symbols table)  
**N** = simmetrico  
**P** = in mandata (solo con cursori 01)

**\***

Flow rating l/min ( $\Delta p$  10 bar)

**A** = 4 l/min  
**1** = 8 l/min  
**2** = 15 l/min  
**3** = 25 l/min  
**6** = 40 l/min

In order to reduced the unloading pressure for rated flow version at 40 l/min we advise to use the 3 way type AM5H3V... hydrostat

**\***

Max. current to solenoid

**E** = 2.35 A  
**F** = 1.76 A  
**G** = 0.88 A

**\*\***

Varianti: see Table 1

**2**

Serial No.

### TABLE 1 - VARIANTS (\*)

No variant (without connectors)	S1
Viton	SV
Rotary emergency	P2
Rotary emergency 180° 180°	R5

(\*) All variants are considered without connectors. The connectors must be order separately. See Cap. I • 20.

### INPUT SIGNAL CURVES - FLOW RATE

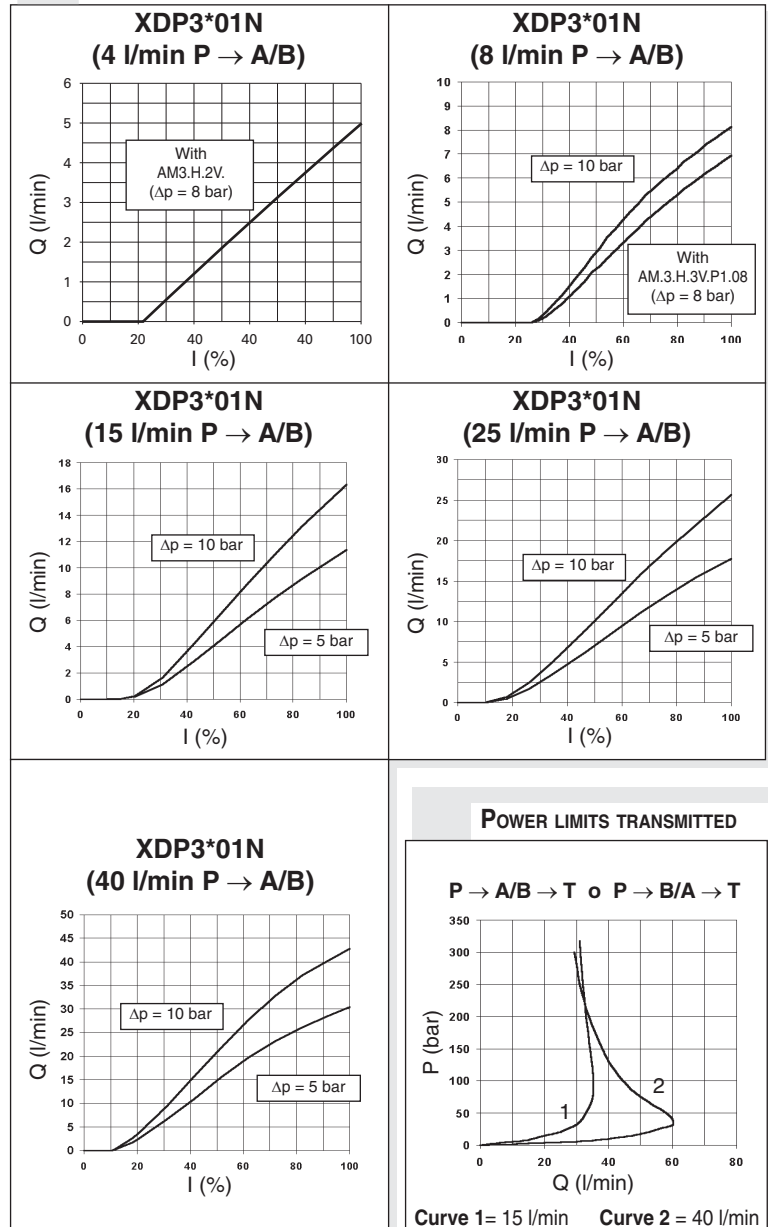

# XDP3A... / XDP3C ... PROPORTIONAL DIRECTIONAL VALVES OPEN LOOP

## OPERATING SPECIFICATIONS

Max. operating pressure ports P/A/B	350 bar		
Max. pressure port T - for dynamic pressure see note (*)	250 bar		
Nominal flow	8 / 15 / 25 / 40 l/min		
Duty cycle	Continuous 100% ED		
Type of protection (depending on the connector used)	IP 65		
Flow rate gain	See diagram		
Power limits curves transmitted	See diagram		
Fluid viscosity	10 ÷ 500 mm <sup>2</sup> /s		
Fluid temperature	-20°C ÷ 75°C		
Ambient temperature	-20°C ÷ 70°C		
Max. contamination level	from class 7 at 9 in accordance with NAS 1638 with filter $\beta_{10} \geq 75$		
Weight XDP3A... (single solenoid)	1,7 Kg		
Weight XDP3C... (double solenoid)	2,9 Kg		

Max. current	<b>2.35A</b>	<b>1.76 A</b>	<b>0.88 A</b>
Solenoid coil resistance 25°C (77°F)	2.25 Ohm	4.0 Ohm	16.0 Ohm
Hysteresis P / A / B / T			
with a pressure compensator AM.3.H.3V...	≤5%	<5%	<8%
Response to step $\Delta p = 5$ bar (P/A)			
0 ÷ 100%	32 ms	40 ms	85 ms
100% ÷ 0	33 ms	33 ms	33 ms
Frequency response -3db (Input signal 50% ±25% Vmax)	22Hz	22Hz	12Hz

(\*) Pressure dynamic allowed for 2 millions of cycles

**Operating specifications are valid for fluids with 46 mm<sup>2</sup>/s viscosity at 40°C, using the specified electronic control units. Performance data carried out using the specified power amplifier SE3AN... serie 1 - EUROCARD format - powered to 24V.**

## AMPLIFIER UNIT AND CONTROL

### REMSRA\*\* and REMDRA\*\*

Electronic card control single and double proportional solenoid valve.  
Recommended dither frequency 100 Hz.

### AM3H2VP1 / AM3H3VP1 and AM5H3VP1 (\*)

Hydrostats 2 or 3 way  
(\*) for rated flow XDP3 version at 40 l/min only

## CONFIGURATION FOR DOUBLE FLOW RATE

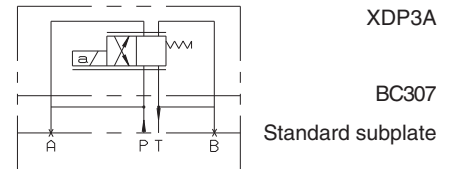

## OVERALL DIMENSIONS

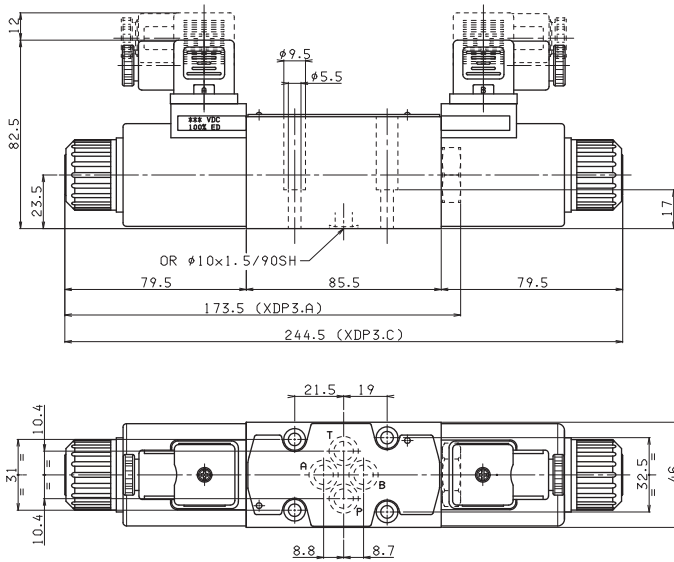

Fixing screws UNI 5931 M5x25  
(min. 8.8 material screws are recommended)  
Tightening torque 4 ÷ 5 Nm / 0.4 ÷ 0.5 Kgm

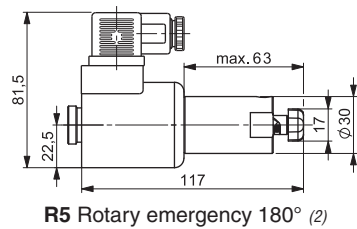
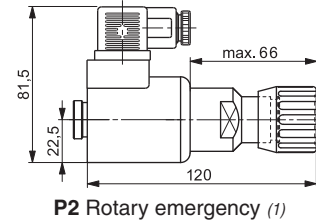
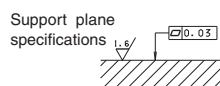

- (1) **P2** - Adjustable hand emergency.  
(2) **R5** - Two positions hand emergency. The regulated flow with emergency actuated can be less than nominal value.

8

## "D15P" PROPORTIONAL SOLENOIDS

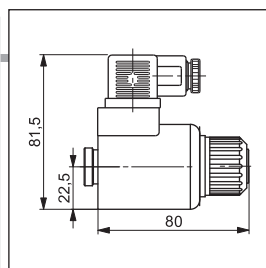

Type of protection (in relation to connector used)	IP 66
Duty cycle	100% ED
Insulation class wire	H
Weight (coil)	0,354 Kg
Weight (solenoid)	0,608 Kg

# XDP5A... / XDP5C ...

## PROPORTIONAL DIRECTIONAL VALVES OPEN LOOP



The open loop valves of series XDP control the direction and the volume of the flow according to the feeding current to the proportional solenoid.



Each  $\Delta p$  variation on the valve leads to the variation of the capacity which has been set, anyway the valve guarantees an high inner compensation grade and limits the adjustment capacity.

**Performances** shown in this catalogue are guaranteed only using 2 or 3 way modular assembly hydrostats type AM5H. ... (see note below in ordering code).

**S5 variant** - This variant that consists of a solenoid chamber drainage separated from the T line and obtained on CETOP RO5 interface allows operation with up to 320 bar max. back pressure on the T line. To ensure maximum solenoid valve mounting safety and supplementary drainage, only 12.9 material fixing screws must be used with it.

XDP.5...	
STANDARD CONNECTORS	CAP. I • 20
"D19P" PROPORT. SOLENOIDS	CAP. VIII • 9
REMSRA...	CAP. IX • 4
REMDRA...	CAP. IX • 7
AM5H...	CAP. VIII • 16

### ORDERING CODE

<b>XDP</b>	Open loop proportional directional valve
<b>5</b>	CETOP 5/NG10
<b>*</b>	A = Single solenoid C = Double solenoid
<b>**</b>	Type of spool (null position)  01 =  03 = 
<b>N</b>	Symmetrical flow path control (see hydraulic symbols table)
<b>*</b>	Flow rating (*) $\Delta p$ 10 bar 2 = 45 l/min 3 = 60 l/min 5 = 100 l/min
<b>*</b>	Max. current to solenoid F = 2.5 A G = 1.25 A
<b>**</b>	Variants: see table 1
<b>1</b>	Serial No.

(\*) Guaranteed with 24Volt, 2.5Amps supply.

### TAB.1 - VARIANTS (\*\*)

No variant (without connectors)	S1
Viton	SV
Rotary emergency	P2
External drainage	S5

(\*\*) All variants are considered without connectors. The connectors must be order separately. See Cap. I • 20.

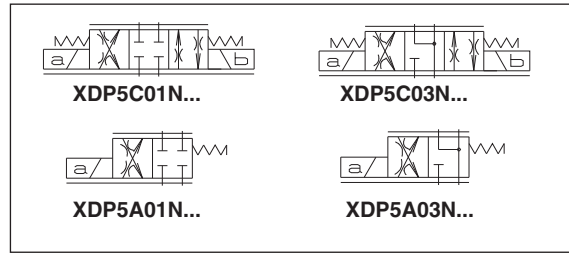

### INPUT SIGNAL CURVES - FLOW RATE

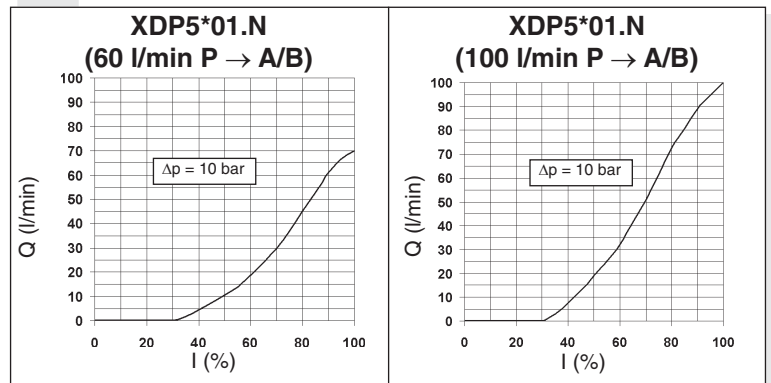

### POWER LIMITS TRANSMITTED

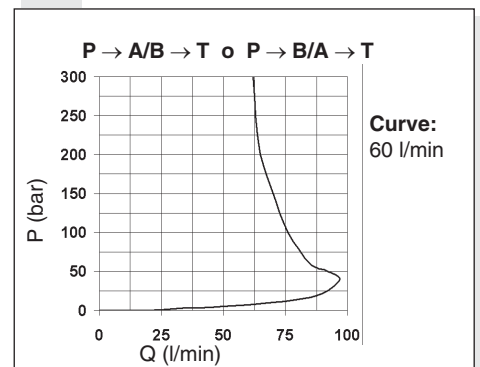

# XDP5A... / XDP5C ... PROPORTIONAL DIRECTIONAL VALVES OPEN LOOP

## OPERATING SPECIFICATIONS

Max. operating pressure ports P/A/B	320 bar
Max. pressure port T - for dynamic pressure see note (*)	250 bar
Max. pressure port T (with external drainage - S5 variant)	320 bar
Nominal flow	45 / 60 / 100 l/min
Duty cycle	Continuous 100% ED
Type of protection (depending on the connector used)	IP 65
Flow rate gain	See diagram
Power limits curves transmitted	See diagram
Fluid viscosity	10 ÷ 500 mm <sup>2</sup> /s
Fluid temperature	-20°C ÷ 75°C
Ambient temperature	-20°C ÷ 70°C
Max. contamination level	from class 7 at 9 in accordance with NAS 1638 with filter $\beta_{10} \geq 75$
Weight XDP5A... (single solenoid)	4,97 Kg
Weight XDP5C... (double solenoid)	6,55 Kg

Max. current	<b>2.5 A</b>	<b>1.25 A</b>
Solenoid coil resistance 20°C (68°F)	2.85 Ohm	11.4 Ohm
Hysteresis P/A/B/T		
with a pressure compensator AM.5.H.3V...	<5%	<8%
Response to step $\Delta p = 10$ bar (P/A)		
0 ÷ 100%	56 ms	118 ms
100% ÷ 0	32 ms	32 ms
Frequency response -3db (Input signal 50% $\pm$ 25% Vmax)		
	10Hz	7Hz

(\*) Pressure dynamic allowed for 2 millions of cycles

Operating specifications are valid for fluids with 46 mm<sup>2</sup>/s viscosity at 40°C, using the specified electronic control units. Performance data carried out using the specified power amplifier type REMSRA... power supplied at 24V.

## AMPLIFIER UNIT AND CONTROL

### REMSRA.\*\* and REMDRA.\*\*.

Electronic card control single and double proportional solenoid valve.  
Recommended dither frequency 100 Hz.

### AM5H2VP1 / AM5H3VP1 ( $\Delta p=10$ bar)

Hydrostats 2 or 3 way.

## OVERALL DIMENSIONS

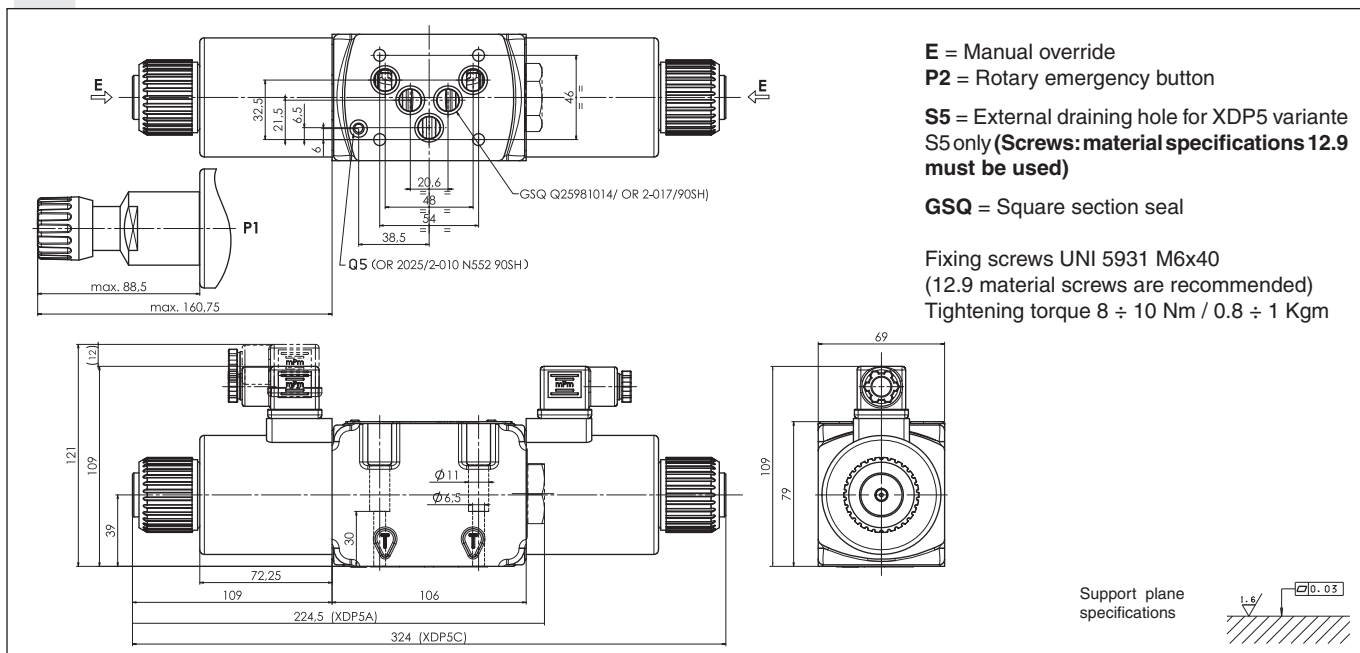

8

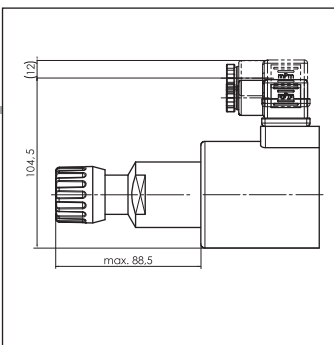

## "D19P" PROPORTIONAL SOLENOIDS

Type of protection (in relation to connector used)	IP 65
Ambient temperature	-25°C ÷ 60°C
Duty cycle	100% ED
Insulation class wire	H
Weight	1,58 Kg

# XDC3... PROPORTIONAL DIRECTIONAL VALVES

## CLOSED LOOP POSITION CONTROL



### XDC3...2

STANDARD CONNECTORS	CAP. I • 20
PROPORTIONAL SOLENOID	CAP. VIII • 11
SE3AN21RS...3	CAP. IX • 11
AM3H...	CAP. VIII • 15
AM5H...	CAP. VIII • 16
BC307...	CAP. VII • 12

The valves XDC serie 2 control the direction and the volume of the flow according to the feeding current to the proportional solenoid. The position transducer type LDVT (inductive position transducer) monitors the actual position of the spool.

In the electronic card (type SE.AN.21.RS...serie 3) the error between the actual position and the reference signal is used to obtain a greater precision of the spool positioning, reducing also considerably the hysteresis and the repeatability error of the valve. For a more accurate flow control, 2 or 3-way pressure compensators modular plate design are available.

The shown flow rates are typical for one line operation (e.g. from P to B). By using the valve with the base for capacity doubling type BC.3.07 greater capacity can be obtained.

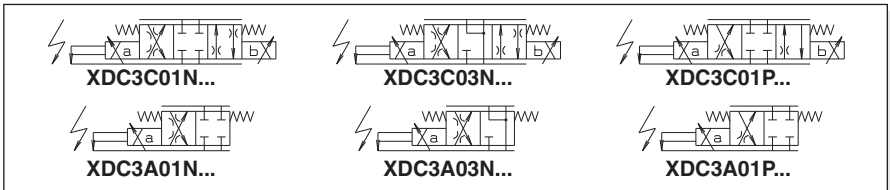

**CE** Registered mark for industrial environment with reference to the electromagnetic compatibility.

European norms: EN50082-2 - general safety norm - industrial environment;  
EN50081-1 - emission general norm - residential environment

### ORDERING CODE

<b>XDC</b>	Proportional directional valve with closed loop position control
<b>3</b>	CETOP 3/NG6
<b>*</b>	<b>A</b> = Single solenoid <b>C</b> = Double solenoid
<b>**</b>	Type of spool (null position) <b>01</b> = <b>03</b> =
<b>*</b>	Flow path control (see hydraulic symbols) <b>N</b> = symmetrical <b>P</b> = meter in (only with 01 spool)
<b>*</b>	Flow rating l/min ( $\Delta p$ 10 bar) <b>A</b> = 4 l/min <b>1</b> = 8 l/min <b>2</b> = 15 l/min <b>3</b> = 25 l/min <b>6</b> = 40 l/min ← In order to reduced the unloading pressure for rated flow version at 40 l/min we advise to use the 3 way type AM5H3V... hydrostat.
<b>F</b>	Max. current at solenoid: 1.76 A
<b>S1</b>	No variant (without connectors)*
<b>2</b>	Serial No.

Notice:  
in order to control the valve XDC3...serie 2 it need to use the electronic card SEAN21RS...serie 3, in exclusive way (See Ch. IX).

(\* All variants are considered without connectors. The connectors must be order separately. See Cap. I • 20.

### INPUT SIGNAL CURVES - FLOW RATE

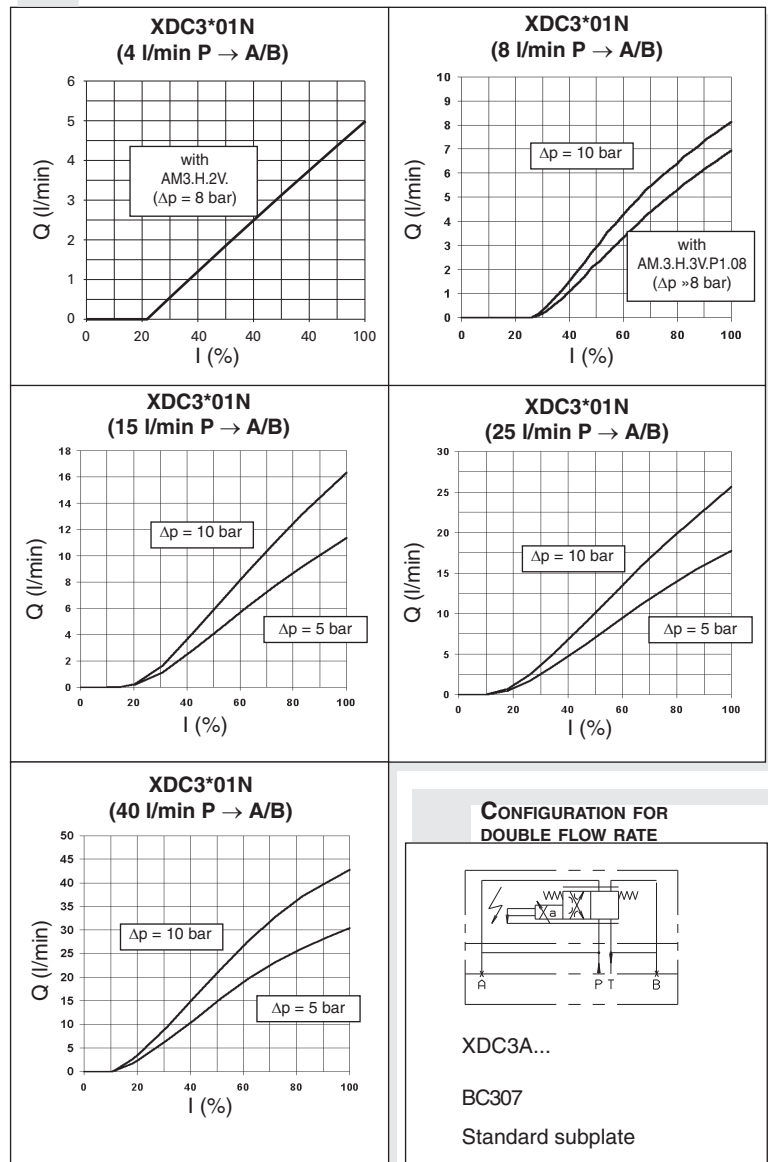

# XDC3... PROPORTIONAL DIRECTIONAL VALVES CLOSED LOOP POSITION CONTROL

## OPERATING SPECIFICATIONS OF VALVE WITH TRANSDUCER

Max. operating pressure ports P/A/B	350 bar
Dynamic pressure port T	210 bar
Static pressure port T	210 bar
Nominal flow	8 / 15 / 25 / 40 l/min
Duty cycle	Continuous 100% ED
Type of protection (depending on the connectors used)	IP 65
Performance curves	See diagrams
Fluid viscosity	10 ÷ 500 mm <sup>2</sup> /s
Fluid temperature	-20°C ÷ 75°C
Ambient temperature	-20°C ÷ 70°C
Max. contamination level	class 7 to 9 in accordance to NAS 1638 with filter $\beta_{10} \geq 75$
Weight XDC3A... (single solenoid)	1,94 Kg
Weight XDC3C... (double solenoid)	2,55 Kg

Max. current	<b>1.76 A</b>
Solenoid coil resistance at 20°C (68°F)	4.55 $\Omega$
Solenoid coil resistance when hot	7.34 $\Omega$
Hysteresis P/A/B/T with pressure compensator AM3H3V...	<1%
Transient function with stepped electrical input signals $\Delta p = 5$ bar (P/A)	
0 ÷ 100%	65 ms
100% ÷ 0	75 ms
Repeatability	<0,5%
Frequency response -3db (Input signal $\pm 25\%$ Vmax)	10 Hz

Insulation class wire	H
Weight of solenoid	0,6 Kg

**Operating specifications are valid for fluids with 46 mm<sup>2</sup>/s viscosity at 40°C, using the SE3AN21RS... serie 3 electronic control unit powered to 24V.**

## AMPLIFIER UNIT AND CONTROL

**SE3AN21RS...serie 3** - Electronic card EURO-CARD format for control of the proportional valve equipped with transducer

**AM3H2VP1 / AM3H3VP1  
AM5H3VP1 (\*)**

Hydrostats 2 or 3 way  
(\* for rated flow XDC3 version at 40 l/min) only

## TRANSDUCER ELECTRICAL CONNECTIONS

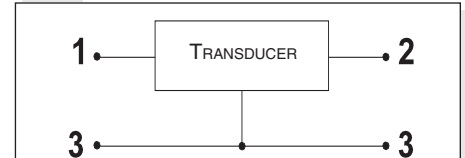

**1** = Supply 18VDC ÷ 36VDC  
**3** = Mass  
**2** = Output 2V ÷ 10V

## POSITION TRANSDUCER SPECIFICATION

Electrical measuring system	LVDT
Nominal stroke	6 mm
Electrical connection	M12x1
Insulation (depending on the connector used)	IP65
Frequency response	500 Hz
Linearity tolerance	$\pm 1\%$

## PROPORTIONAL SOLENOID

### OVERALL DIMENSIONS

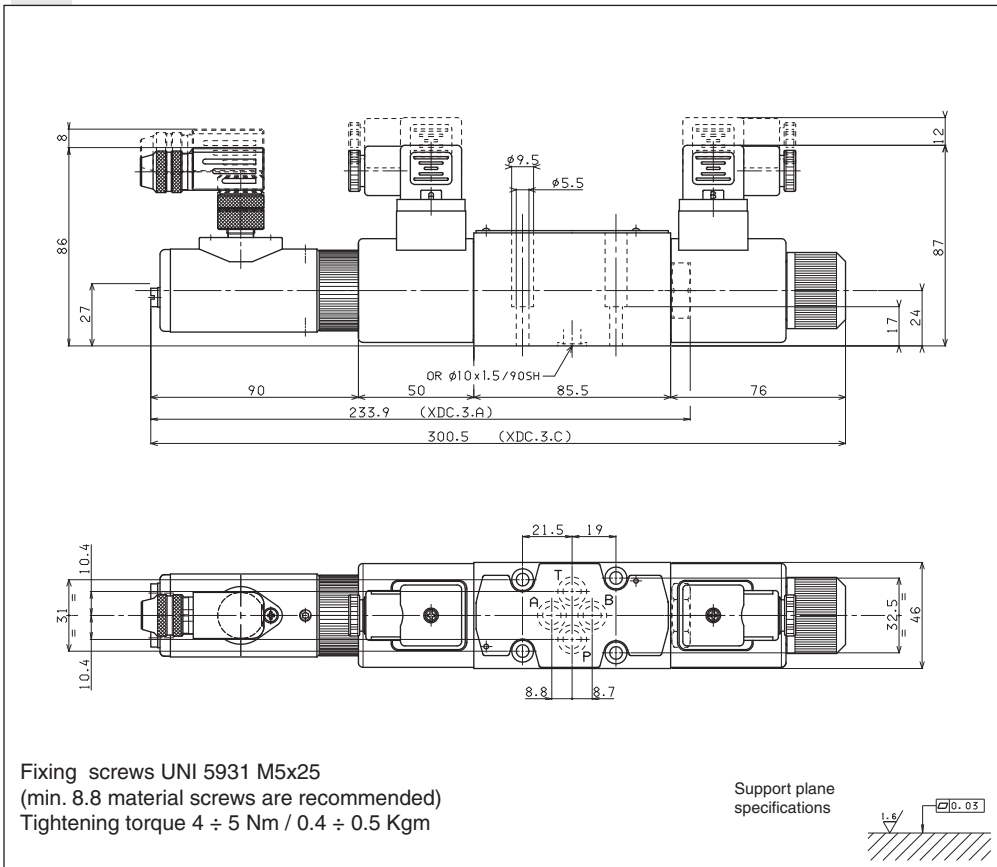

**8**

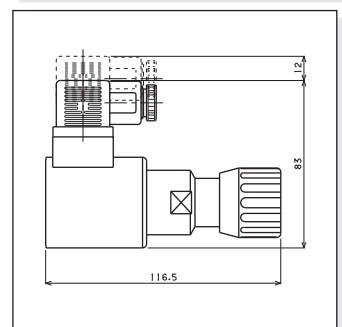
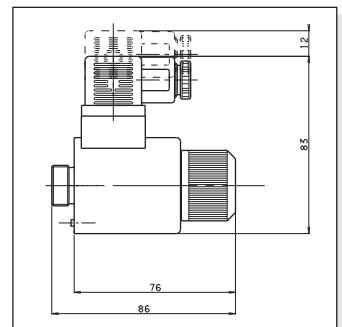

# XEPV3... PROPORTIONAL VALVE WITH ELECTRONIC ON BOARD



The proportional directional valves XEPV are designed as direct operated components for subplate mounting. They are actuated by means of proportional solenoids with central thread and removable coil. The solenoids are controlled by integrated control electronics.

**Features:**

- Integrated control electronics
- Setup parameters by CAN interface
- Current compensation, gain current and ramps setting
- Monitoring of the valve by real time scope interface

**European norms: EN 61000 - ElectroMagnetic Compatibility (EMC) - industrial environment**

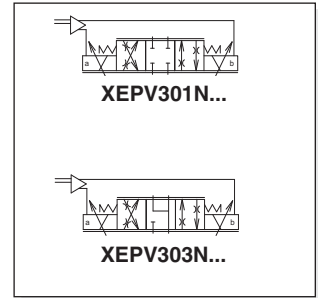

XEPV3...	
AM3H...	CAP. VIII • 15
AM5H...	CAP. VIII • 16
BC307...	CAP. VII • 12

**ORDERING CODE**

- XEPV** Current loop proportional valve with integrated electronics 24Vdc
- 3** CETOP 3/NG6
- \*\*** Type of spool
  - 01** = spool with P, A, B and T ports, closed
  - 03** = spool with P port closed, and A, B, T ports connected
- N** Symmetrical flow control
- \*** Flow rating at  $\Delta P$  8 bar
  - 0** = 4 l/min
  - 1** = 8 l/min
  - 2** = 15 l/min
  - 3** = 25 l/min
  - 6** = 36 l/min (we advise to use the hydrostat AM5H3VP108)
- S** CAN bus communication  
**S** = standard
- W** Command Enable  
**W** = without external command Enable
- \*** Type command  
**V** = signal voltage  $\pm 10V$   
**C** = signal current 4... 20mA
- 00** No variants
- 1** Serial No.

**INPUT SIGNAL CURVES - FLOW RATE**

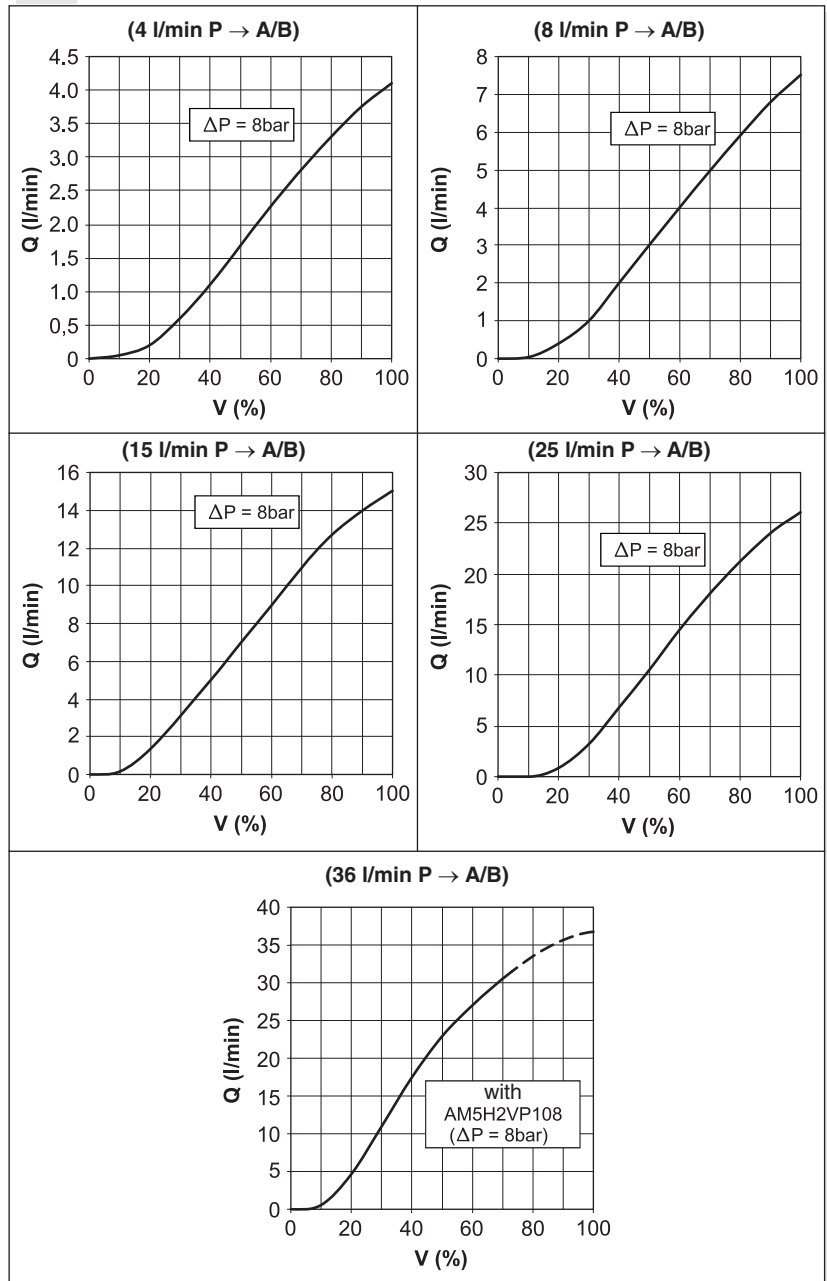



# XEPV3... PROPORTIONAL VALVE WITH ELECTRONIC ON BOARD

## STEP RESPONSE ( $\Delta p = 8 \text{ bar P/A}$ )

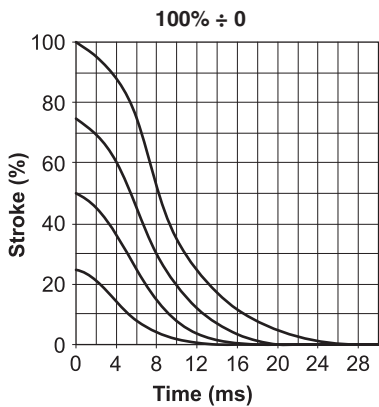
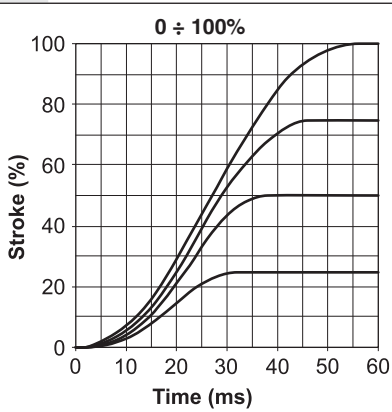

## OPERATING SPECIFICATIONS OF VALVE WITH TRANSDUCER

Installation	must keep horizontal
Max. operating pressure ports P/A/B	350 bar
Dynamic pressure port T	210 bar
Static pressure port T	210 bar
Nominal flow	4 / 8 / 15 / 25 / 36 l/min
Performance curves	See diagrams
Fluid temperature	-20 ÷ 75°C (preferably 40 ÷ 50°C)
Fluid viscosity	10 ÷ 500 mm <sup>2</sup> /s
Max. contamination level	class 7 to 9 in accordance to NAS 1638 with filter $\beta_{10} \geq 75$
Weight	2.45 kg
Nominal supply voltage	24Vdc
Input signal range (see ordering code)	± 10V or 4...20mA
Supply voltage lower limit	18V
Supply voltage upper limit	30V
Peak power	50W
Max. coil temperature	150 °C
Duty cycle	Continuous 100% ED
Hysteresis	< 5%
Response sensitivity	< 0.5%
Repeatability	< 0.5%
Fault signal output	0V = failure or not working valve 24V = valve OK
Current monitor	± 10V
Ambient temperature range	-20 ÷ 60°C
Type of protection	IP 65

Operating specifications are valid for fluids with 46 mm<sup>2</sup>/s viscosity at 40°C.

## OVERALL DIMENSIONS

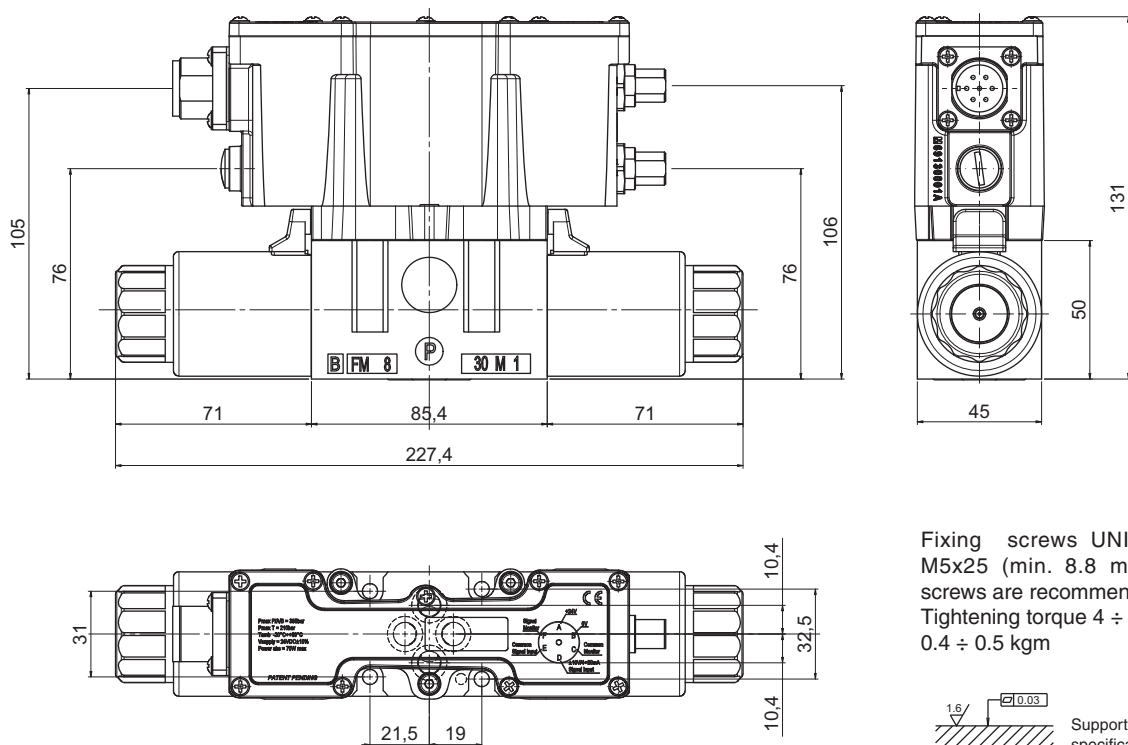

Fixing screws UNI 5931 M5x25 (min. 8.8 material screws are recommended)  
Tightening torque 4 ÷ 5 Nm / 0.4 ÷ 0.5 kgm

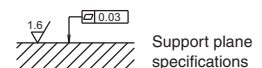

# XEPV3... PROPORTIONAL VALVE WITH ELECTRONIC ON BOARD

## ELECTRICAL CONNECTIONS

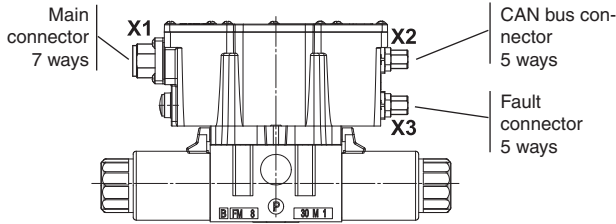

- A positive command value 0 to +10V (or 12 to 20mA) at D and the reference potential at E, results in a flow from P to A and B to T.
- A negative command value 0 to -10V (or 12 to 4mA) at D and the reference potential at E, results in a flow from P to B and A to T.

### X1: Main connector 7 ways (supplied with the valve)

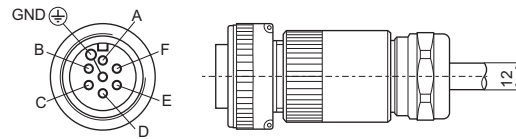

DIN EN 175201-804 - 7 poles female

Type	PIN	Description
Main power supply	A	+24Vdc
	B	0V / common supply
0V / common of signal monitor	C	0V / common of signal monitor
Input of differential signal command	D	± 10V or 4...20mA
	E	0V / common
Output of signal monitor	F	± 10V (10V = max current)
	GND	GND

Connection cable recommended: up to 50m cable length type LiYCY 7x1.0 mm<sup>2</sup>. For outside diameter see plug-in connector sketch. Only connect screen to PE on the supply side.

### X2\*: 5 ways M12 connector, CAN communication (to be ordered separately)

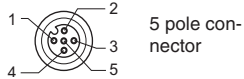

5 pole connector

5 ways connector code: VE0032700

IEC 61076-2-101 - 5 poles female

Type	PIN	Description
CAN data interface	1	CAN_H
	2	CAN_L
	3	
	4	
	5	GND

\* Connection cable recommended: up to 50m cable length type LiYCY 7x0.75 mm<sup>2</sup>. For outside diameter see plug-in connector sketch. Only connect screen to PE on the supply side.

### X3\*: 5 ways M12 connector - Fault digital command (to be ordered separately)

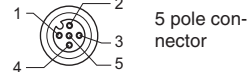

5 pole connector

5 ways connector code: VE0032700

IEC 61076-2-101 - 5 poles female

Type	PIN	Description
Digital output signal of valve FAULT	1	Connects to +24Vdc
	2	Signal out: 0V = failure of electronic control 24V = valve OK
	3-4-5	Not used

8

## SOFTWARE AND CABLES

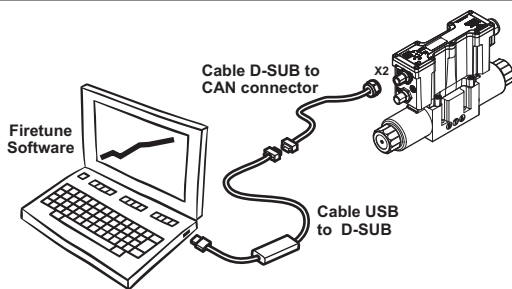

### INTERFACE FOR SETUP PARAMETERS

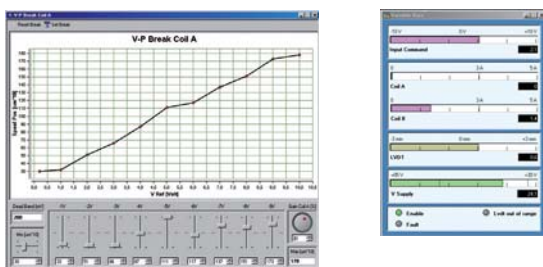

Firetune software code: P35150005

For further information about Firetune read the manual. The software is included with valve supply.

### ADAPTER FOR PC: CABLE USB TO D-SUB



Model: KVASER Leaf light HS (not supplied, commercial parts)

### ADAPTER FOR PC: CABLE D-SUB TO CAN CONNECTOR

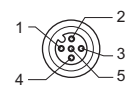

CAN connector

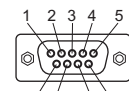

D-Sub connector (female)

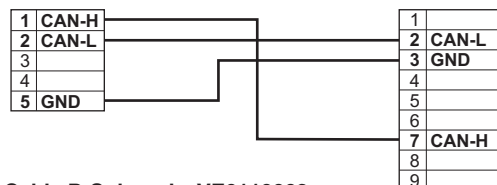

Cable D-Sub code: VE0110002

# AM3H... 2 AND 3 WAY HYDROSTATS CETOP 3



AM3H...

The 2 or 3 way pressure regulator type AM3H ensure the constant set flow rate in the presence of varying system load (pressure) by keeping constant the pressure drop ( $\Delta p = 4/8$  bar) in relation to the flow rate regulation.

In order to achieve the direction and flow rate dual control function, it is normally used together with a proportional solenoid valve

Max. flow	25 l/min
Max. operating pressure	350 bar
$\Delta p$ adjustment	4 bar 8 bar
Fluid viscosity	10 ÷ 500 mm <sup>2</sup> /s
Fluid temperature	-25°C ÷ 75°C
Ambient temperature	-25°C ÷ 60°C
Max. contamination level	class 8 in accordance with NAS 1638 with filter $\beta_{10} \geq 75$
Weight	1,4 Kg

### ORDERING CODE

<b>AM</b>	Modular valve
<b>3</b>	CETOP 3/NG6
<b>H</b>	Hydrostat
<b>**</b>	<b>2V</b> = 2 way <b>3V</b> = 3 way
<b>P1</b>	Function at port P
<b>**</b>	Differential pressure ( $\Delta p$ ) <b>04</b> = $\Delta p$ 4 bar <b>08</b> = $\Delta p$ 8 bar
<b>**</b>	<b>00</b> = No variant <b>V1</b> = Viton
<b>2</b>	Serial No.

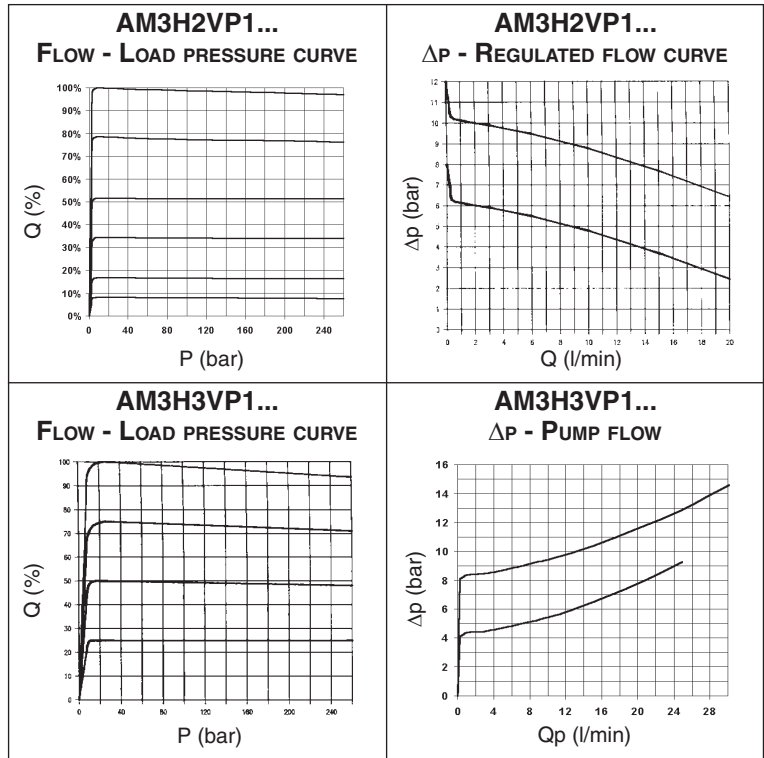

8

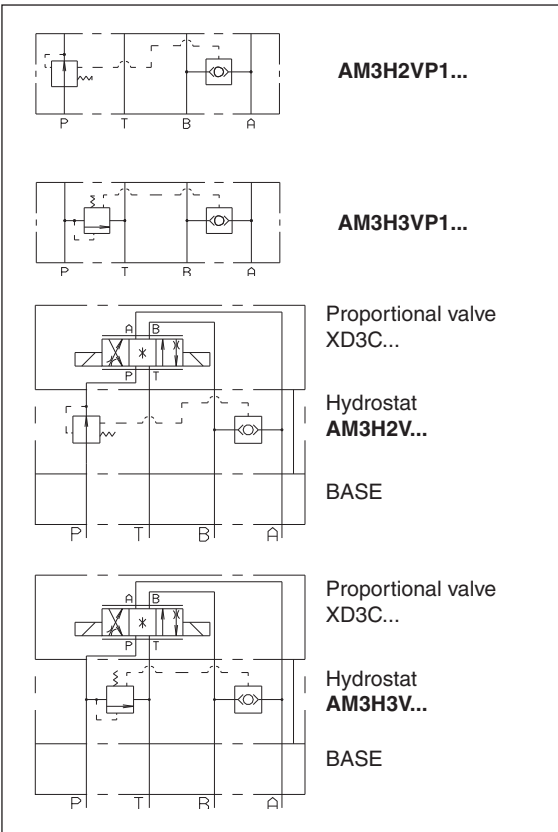

### OVERALL DIMENSIONS

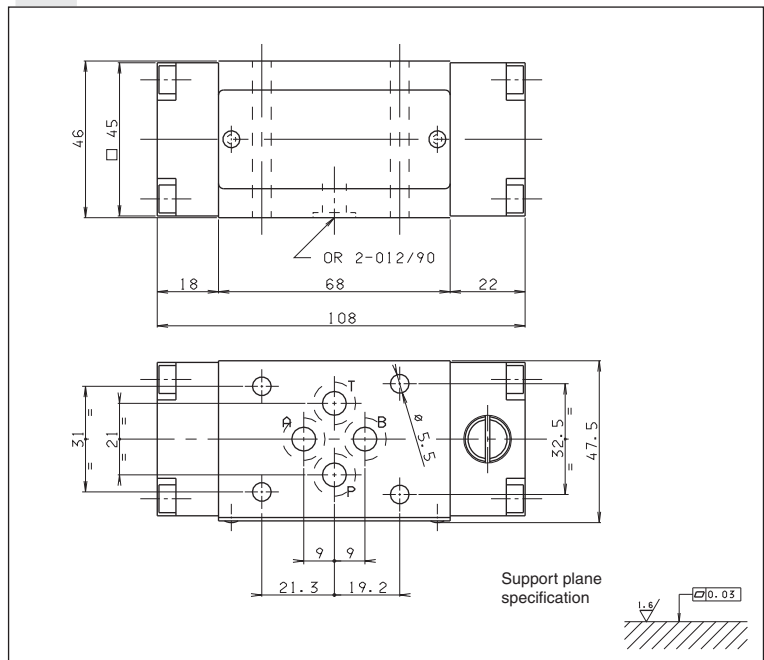

# AM5H... 2 AND 3 WAY HYDROSTATS CETOP 5



AM5H...

The 2 or 3 way pressure regulator type AM5H ensures a constant set flow rate in the presence of varying system load (pressure) by keeping constant the pressure drop ( $\Delta p=8$  bar) in relation to the flow rate regulation. In order to achieve the direction and flow rate dual control function, it is normally used together with a proportional solenoid valve.

Max. flow AM5H2V...	65 l/min
Max. flow AM5H3V...	70 l/min
Max. operating pressure	350 bar
$\Delta p$ adjustment	8 bar
Fluid viscosity	$10 \div 500 \text{ mm}^2/\text{s}$
Fluid temperature	$-25^\circ\text{C} \div 75^\circ\text{C}$
Ambient temperature	$-25^\circ\text{C} \div 60^\circ\text{C}$
Max. contamination level class 8 in accordance with NAS 1638 with filter $\beta_{10} \geq 75$	
Weight	2,7 Kg

### ORDERING CODE

<b>AM</b>	Modular valve
<b>5</b>	CETOP 5/NG10
<b>H</b>	Hydrostat
<b>**</b>	<b>2V</b> = 2 way <b>3V</b> = 3 way
<b>P1</b>	Function at port P
<b>08</b>	Differential pressure ( $\Delta p$ ) $\Delta p$ 8 bar
<b>**</b>	<b>00</b> = No variant <b>V1</b> = Viton
<b>2</b>	Serial No.

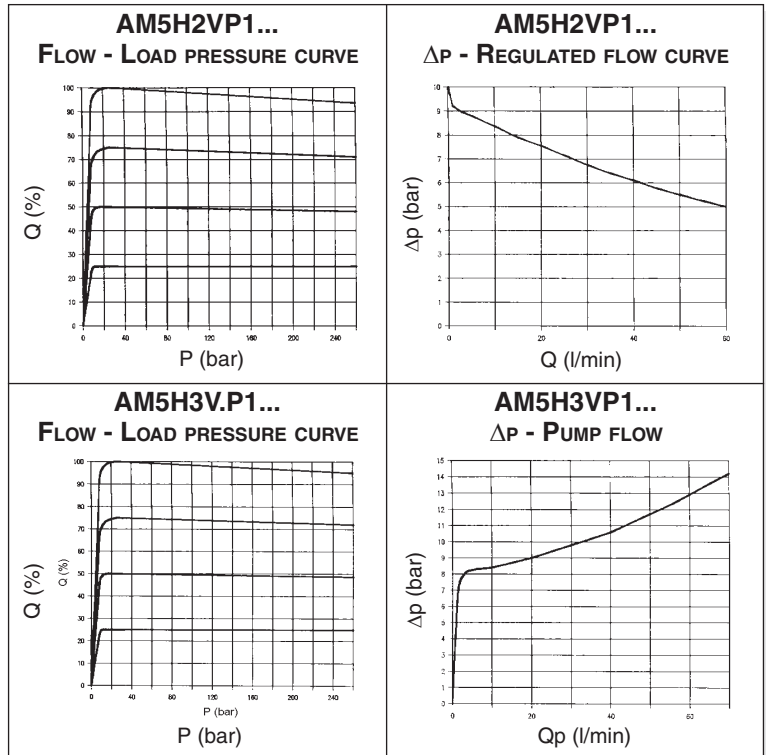

8

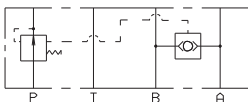

AM5H2VP1...

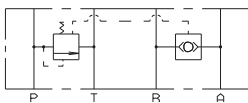

AM5H3VP1...

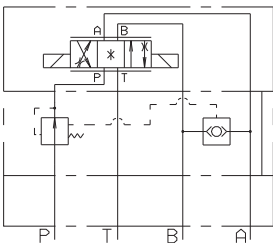

Proportional valve  
XD5C...

Hydrostat  
AM5H2V...

BASE

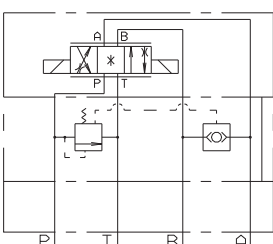

Proportional valve  
XD5C...

Hydrostat  
AM5H3V...

BASE

### OVERALL DIMENSIONS

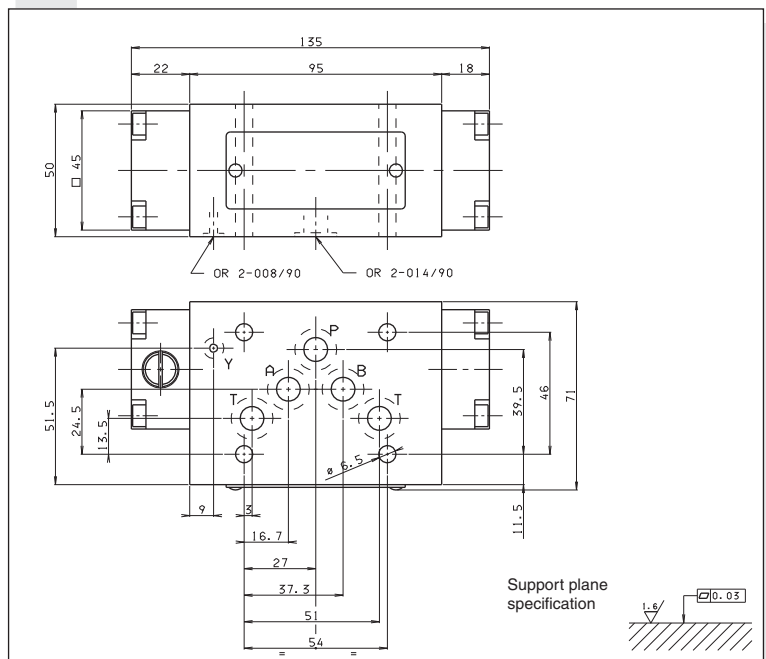

# XQ3... PROPORTIONAL FLOW CONTROL VALVES PRESSURE COMPENSATED CETOP 3



XQ3...	
STANDARD CONNECTORS	CAP. I • 20
"D15P" PROPORT. SOLENOIDS	CAP. VIII • 18
REMSRA...	CAP. IX • 4
BC308. / BC309. / BC06XQ3.	CAP. VII • 13

This is a proportional valve where both the flow rate and pressure control flow functions have been integrated according to the 3 way regulation concept.

The interface UNI ISO 4401 - 03 - 02 - 0 - 94 standard (ex CETOP R 35 H 4.2-4-03) allows for direct mounting on modular block or multiple sub-bases, which makes possible many advantageous and extremely compact application solution as a consequence of their simplicity of installation.

The 3 way type pressure compensator, inserted into the valve, holds the pressure drop across the flow rate proportional regulator constant (approx. 8 bar) independently from the controlled load variations, whereby ensuring proportional between the set flow rate and the electrical command signal.

Additionally, the system maximum safety pressure can be regulated through a manual command. This valve, if mounted on the feed line to the manifold block, can be used to control several circuits which are not operating at the same time.

## ORDERING CODE

<b>XQ</b>	Proportional flow control valve
<b>3</b>	No. of way
<b>C</b>	Pressure compensation
<b>3</b>	CETOP 3/NG6
*	Flow rates F = 5 l/min G = 10 l/min H = 16 l/min I = 28 l/min
*	M = With manual pressure limiter S = Without manual pressure limiter
*	Setting ranges 1 = 8 ÷ 50 bar 2 = 25 ÷ 170 bar 3 = 50 ÷ 315 bar Omit for XQ3C*S version
*	E = With rotary emergency (type P2) S = Without rotary emergency
*	Voltage E = 9VDC (2,35 A) F = 12VDC (1.76 A) G = 24VDC (0.88 A)
**	Variant (*):
<b>2</b>	Serial No.

**TAB.1 - VARIANTS (\*)**

No variant (without connectors)	S1
Viton	SV
Emergency lever	L5
Rotary emergency 180°	R5

(\*) All variants are considered without connectors. The connectors must be order separately. See Cap. I • 20.

## DIAGRAMS

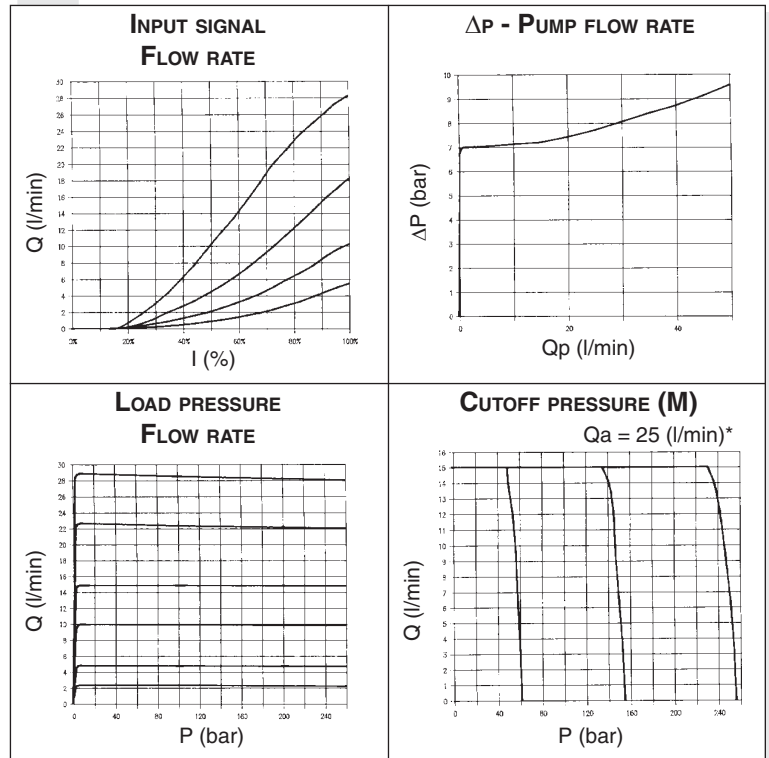

The fluid used is a mineral based oil with a viscosity of 46 mm<sup>2</sup>/s at 40°C. The tests have been carried out with a fluid of a 40°C.

(\*) Tested with 25 l/min supply

**TABLE 1 - FLOW / PRESSURE SPECIFICATIONS**

Model	Hydraulic symbol	Max flow rate (l/min)	Max flow in P (l/min)	Max limiter pressure (bar)	Max load pressure (bar)	Δp Control (bar)
<b>XQ3C3*M</b>		5	40	8÷50	250	8
		10		25÷170		
		16		50÷315		
		28				
<b>XQ3C3*S</b>		5	40		250	8
		10				
		16				
		28				



# XQP3... OPEN LOOP 2/3 WAY PROPORTIONAL PRESSURE COMPENSATED FLOW REGULATORS



The open loop proportional flow regulator is 2 and 3 way compensated with priority function. It is designed to regulate flow in proportion to an applied electrical current (REM or SE3AN power amplifier). Flow regulation is load independent - B port. Load compensation is achieved by a spool compensator which holds the pressure drop constant across the proportional spool.

Valves are available in the following versions (see hydraulic symbol):

- 2 way pressure compensated - 3 way pressure compensated with priority function.
- 3 way pressure compensated with priority and venting function.



• In order to obtain the 2 way pressure compensated version the cavities P and T have to be closed on the subplate.

## HYDRAULIC SYMBOLS

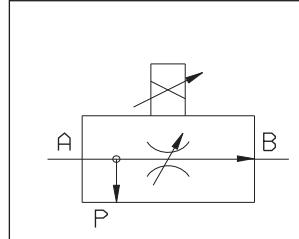

• In order to obtain the 3 way pressure compensated version the cavity T have to be closed on the subplate.

## XQP3...

STANDARD CONNECTORS	CAP. I • 20
"D15P" PROPORT. SOLENOIDS	CAP. VIII • 20
REMSRA...	CAP. IX • 4
BC06XQP3...	CAP. VII • 13

## ORDERING CODE

**XQP**

Open loop 2/3 way proportional compensated flow regulator

**3**

CETOP 3/NG6

**C**

2/3 way compensation with priority function

**3**

3 way version (standard)  
For to obtain 2-way version the P line must be closed on the subplate

**\***

Nominal flow rates

- F = 6 l/min
- G = 12 l/min
- H = 22 l/min
- I = 32 l/min
- L = 40 l/min

**\***

S = without decompression  
D = with decompression

**\***

Max. current to solenoid

- E = 2.35 A
- F = 1.76 A
- G = 0.88 A

**\*\***

Variants (\*):

- S1 = No variant
- P2 = Rotary emergency
- R5 = Rotary emergency 180°
- SV = Viton

**2**

Serial No.

## DIAGRAMS

$\Delta P$  - FLOW RATE A → B  
(WITH 5 l/min TO P)

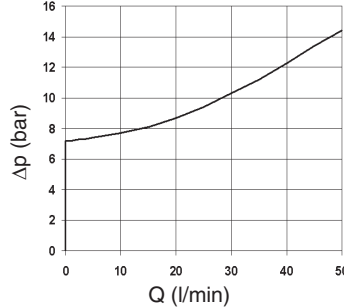

$\Delta P$  - SECONDARY LINE FLOW  
(A → P FREE)

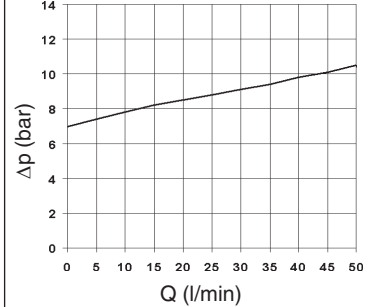

## FLOW RATE

BACK PRESSURE ON PRIORITY LINE

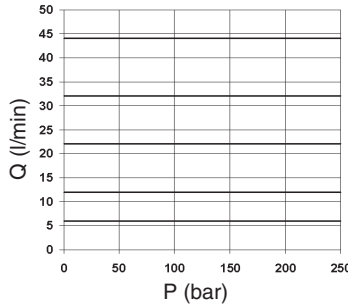

## FLOW RATE

BACK PRESSURE ON SECONDARY LINE

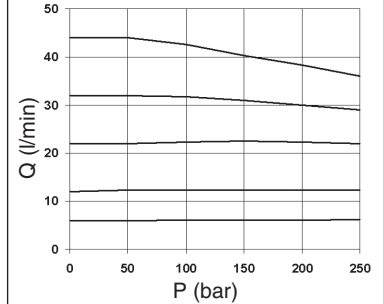

INPUT SIGNAL  
FLOW

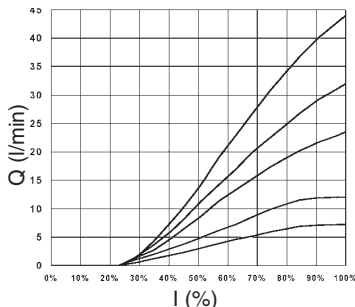

2 WAY COMPENSATION  
(A 270 bar - B VARIABLE)

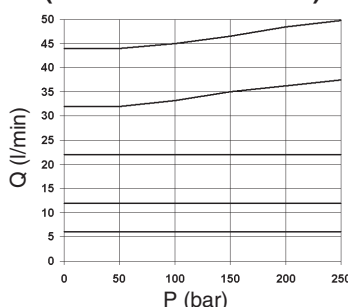

2 WAY COMPENSATION  
(A VARIABLE - B 30 bar)

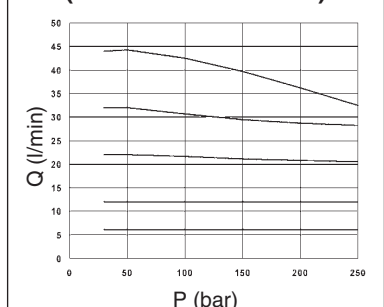

(\* All variants are considered without connectors. The connectors must be order separately. See Cap. I • 20.

The fluid used is a mineral based oil with a viscosity of 46 mm<sup>2</sup>/s at 40°C. The tests have been carried out at with a fluid of a 40°C.

# XQP3... OPEN LOOP 2/3 WAY PROPORTIONAL PRESSURE COMPENSATED FLOW REGULATORS

## OPERATING SPECIFICATIONS

Max. operat. pressure ports A/B /P see note (*) With T port blocked on subplate	250 bar		
Regulated flow rate	6 / 12 / 22 / 32 / 40 l/min		
Decompression drain flow	max 0,7 l/min		
Relative duty cycle	Continuous 100% ED		
Type of protection (in relation to the connector used)	IP 65		
Flow rate gain	See diagram "Input signal flow"		
Fluid viscosity	10 ÷ 500 mm <sup>2</sup> /s		
Fluid temperature	-20°C ÷ 75°C		
Ambient temperature	-20°C ÷ 70°C		
Max. contamination level	from class 7 to 9 in accordance with NAS 1638 with filter $\beta_{10} \geq 75$		
Weight	1,7 Kg		

Max. current	<b>2.33A</b>	<b>1.76 A</b>	<b>0.88 A</b>
Solenoid coil resistance at 25°C (77°F)	2.25 Ohm	4.0 Ohm	16.0 Ohm
Hysteresis with $\Delta p$ 7 bar	≤5%	<5%	<8%
Response to step $\Delta p = 7$ bar			
0 ÷ 100%	32 ms	40 ms	85 ms
100% ÷ 0	33 ms	33 ms	33 ms
Frequency response -3db (Input signal 50% ± 25% Vmax.)	22Hz	22Hz	12Hz

(\*) Pressure dynamic allowed for 2 millions of cycles

**Operating specifications are valid for fluids with 46 mm<sup>2</sup>/s viscosity at 40°C, using specified electronic control units.**

**Performance data are carried out using the specified power amplifier SE3AN... powered to 24V.**

## AMPLIFIER UNIT AND CONTROL

### REMSRA\*\*...

Electronic card for control single proportional solenoid valve.

Recommended dither frequency 100 Hz.

## OVERALL DIMENSIONS

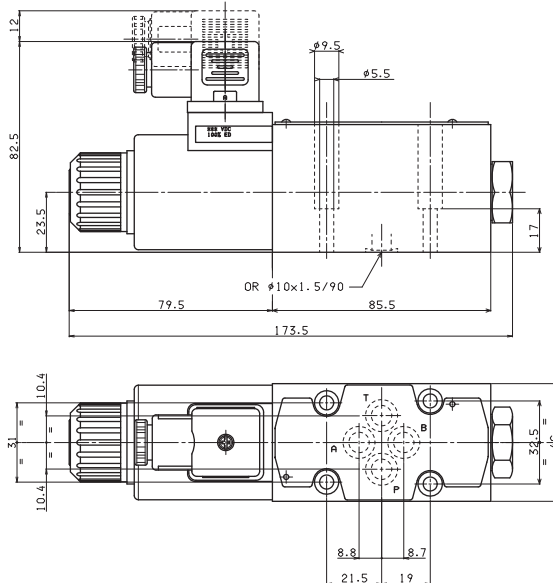

Fixing screws UNI 5931 M5x25  
(min. 8.8 material screws are recommended)  
Tightening torque 4 ÷ 5 Nm / 0.4 ÷ 0.5 Kgm

Support plane specifications

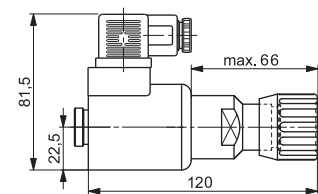
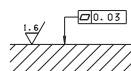

**P2 Rotary emergency (1)**

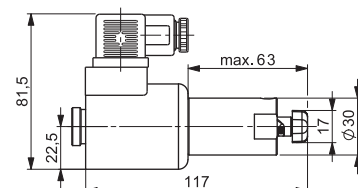

**R5 Rotary emergency 180° (2)**

(1) **P2** - Adjustable hand emergency.

(2) **R5** - Two positions hand emergency. The regulated flow with emergency actuated can be less than nominal value.

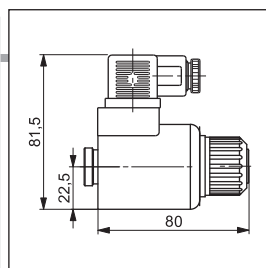

## "D15P" PROPORTIONAL SOLENOIDS

Type of protection (in relation to connector used)	IP 66
Duty cycle	100% ED
Insulation class wire	H
Weight (coil)	0,354 Kg
Weight (solenoid)	0,608 Kg



# XQP5 OPEN LOOP 2/3 WAY PROPORTIONAL PRESSURE COMPENSATED FLOW REGULATORS CETOP 5



<b>XQP5...</b>	
STANDARD CONNECTORS	CAP. I • 20
"D19P" PROPORT. SOLENOIDS	CAP. VIII • 22
REMSRA...	CAP. IX • 4

The open loop proportional flow regulator is 2 and 3 way compensated with priority function. It is designed to regulate flow in proportion to an applied electrical current (REM power amplifier). Flow regulation is load independent - B port. Load compensation is achieved by a spool compensator which holds the pressure drop constant across the proportional spool.

Valves are available in the following versions (see hydraulic symbol):

- 2 way pressure compensated
- 3 way pressure compensated with priority function.
- 3 way pressure compensated with priority and venting function.

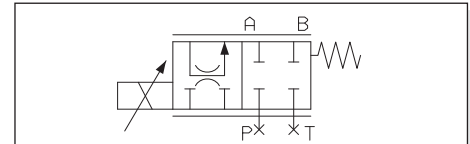

• In order to obtain the 2 way pressure compensated version the cavities P and T have to be closed on the subplate.

## SYMBOLS HYDRAULIC

### SIMPLIFIED TYPE

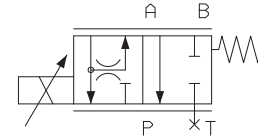
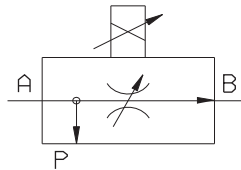

• In order to obtain the 3 way pressure compensated version the cavities T have to be closed on the subplate.

## ORDERING CODE

**XQP**

Open loop 2/3 way proportional compensated flow regulator

**5**

CETOP 5/NG10

**C**

2/3 way compensation with priority function

**3**

3 way version (standard)  
For to obtain 2-way version the P line must be closed on the subplate

**\***

Nominal flow rates  
**E** = 45 l/min  
**F** = 75 l/min  
**G** = 105 l/min

**\***

**S** = without decompression  
**D** = with decompression

**\***

Voltage  
**F** = 12V DC  
**G** = 24V DC

**\*\***

Variant (\*):  
**S1** = No variant (without connectors)  
**SV** = Viton  
**P2** = Rotary emergency

**1**

Serial No.

## DIAGRAMS

$\Delta P$  - FLOW RATE A  $\rightarrow$  B  
(WITH 5 l/min TO P)

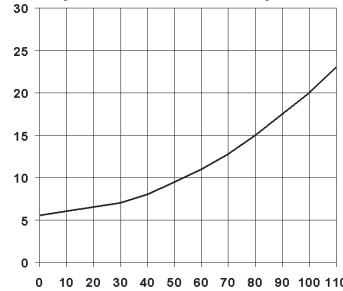

$\Delta P$  - SECONDARY LINE FLOW  
(A  $\rightarrow$  P FREE)

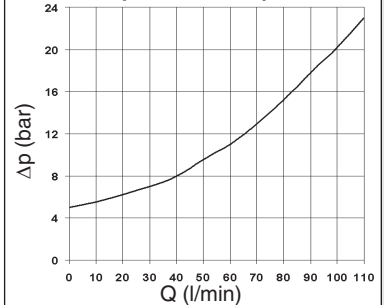

### FLOW RATE

BACK PRESSURE ON PRIORITY LINE

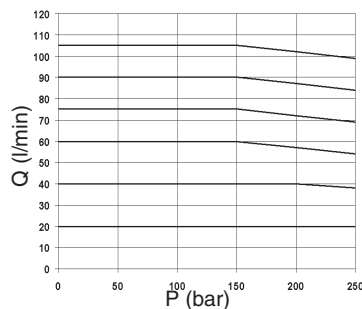

### FLOW RATE

BACK PRESSURE ON SECONDARY LINE

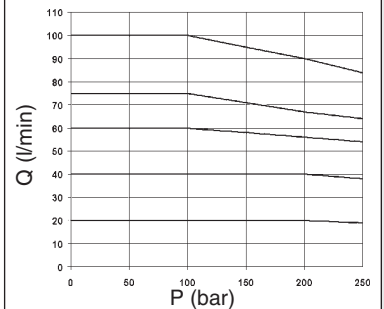

INPUT SIGNAL  
FLOW

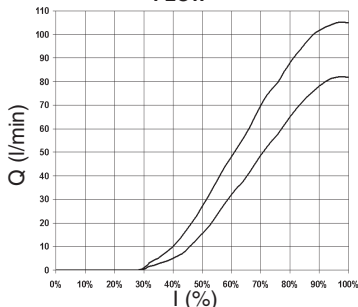

2 WAY PRESSURE COMPENSATED  
(A 270 bar - B VARIABLE)

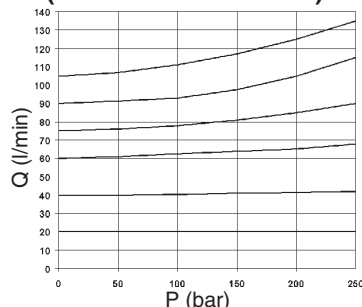

2 WAY PRESSURE COMPENSATED  
(A VARIABLE - B 30 bar)

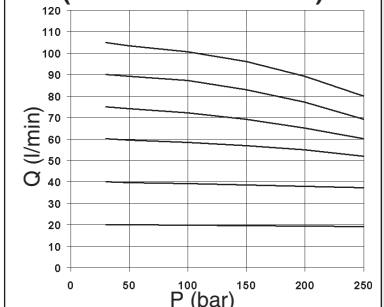

(\* All variants are considered without connectors. The connectors must be order separately. See Cap. I • 20.

The fluid used is a mineral based oil with a viscosity of 46 mm<sup>2</sup>/s at 40°C.  
The tests have been carried out at with a fluid of a 40°C.

# XQP5 OPEN LOOP 2/3 WAY PROPORTIONAL PRESSURE COMPENSATED FLOW REGULATORS CETOP 5

## OPERATING SPECIFICATIONS

Max. operating pressure ports A/B / P (*)	250 bar
Regulated flow rate	75 / 105 l/min
Decompression drain flow	max 0,7 l/min
Relative duty cycle	Continuous 100% ED
Type of protection (in relation to the connector used)	IP 65
Flow rate gain	See diagram "Input signal flow"
Fluid viscosity	10 ÷ 500 mm <sup>2</sup> /s
Fluid temperature	-20°C ÷ 75°C
Ambient temperature	-20°C ÷ 60°C
Max. contamination level	from class 7 to 9 in accordance with NAS 1638 with filter $\beta_{10} \geq 75$
Weight	4,97 Kg

Type of voltage	<b>12V</b>	<b>24V</b>
Max. current	2.5 A	1.25 A
Solenoid coil resistance at 20°C (68°F)	2.85 Ohm	11.4 Ohm

Hysteresis with $\Delta p$ 7 bar	<5%	<8%
Response to step $\Delta p = 7$ bar (P/A)		
0 ÷ 100%	~ 65 ms	-
100% ÷ 0	~ 30 ms	-
Frequency response -3db (Input signal 50% ± 25% Vmax.)	7Hz	-

## AMPLIFIER UNIT AND CONTROL

### REMSRA\*\*...

Electronic regulator for control single proportional solenoid valve.  
Recommended dither frequency 100 Hz.

(\*) Pressure dynamic allowed for 2 millions of cycles. T ports closed on the subplate.

**Operating specifications are valid for fluids with 46 mm<sup>2</sup>/s viscosity at 40°C, using specified electronic control units.**

**Performance data are carried out using the specified power amplifier type REMSRA... power supplied at 24V.**

## OVERALL DIMENSIONS

E = Manual override

GSQ = Square section seal

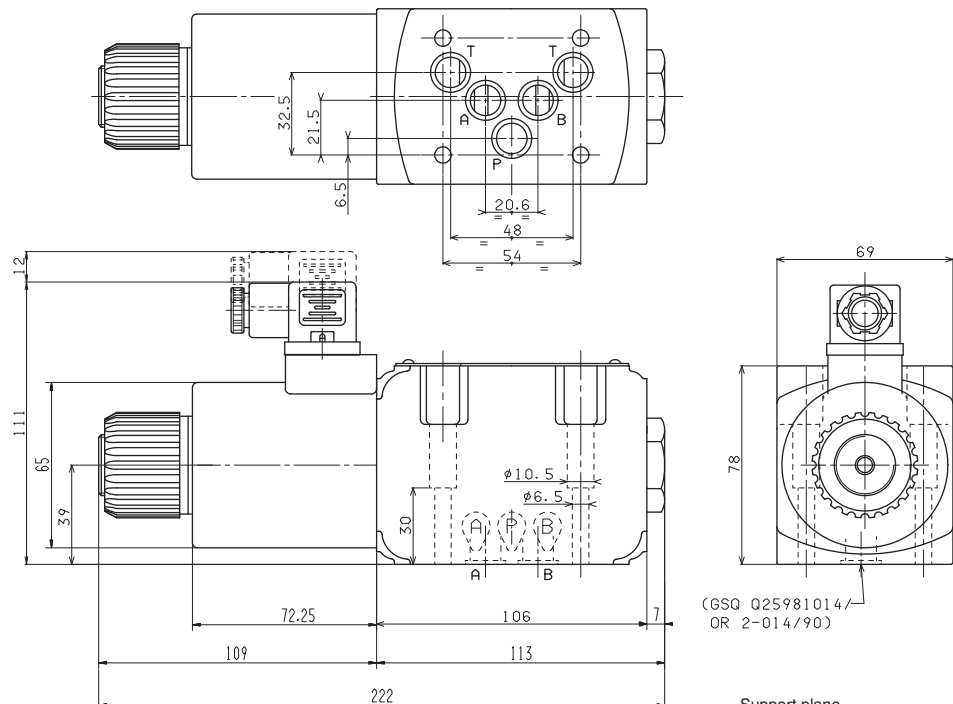

Fixing screws UNI 5931 M6x40  
(12.9 material screws are recommended)  
Tightening torque 8 ÷ 10 Nm / 0.8 ÷ 1 Kgm

Support plane specifications

8

## "D19P" PROPORTIONAL SOLENOIDS

Type of protection (in relation to connector used)	IP 65
Ambient temperature	-54°C ÷ 60°C
Duty cycle	100% ED
Insulation class wire	H
Weight	1,58 Kg

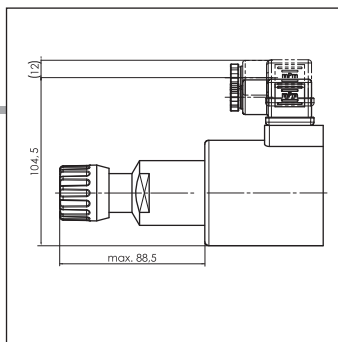

# XP3... PROPORTIONAL PRESSURE CONTROL VALVES CETOP 3/NG6



Proportional maximum pressure valves type XP3.\*.. are used to regulate a hydraulic circuit pressure by means of a variable electric signal. Their precise implementation allows for high and constant operational standard up to a maximum 2,5 l/min flow rate. A manually pressure limit setting version is also available, to protect the system from uncontrolled electrical signals.

• Other valves (e.g. subplate or in-line mounted valves) should be ordered separately.

XP3...	
STANDARD CONNECTORS	CAP. I • 20
VMP / VML / VMPE	CAP. II • 6
REMSRA...	CAP. IX • 4

## ORDERING CODE

<b>XP</b>	Max. pressure valve
<b>3</b>	CETOP 3/NG6
<b>*</b>	<b>1</b> = max. 50 bar <b>2</b> = max. 140 bar <b>3</b> = max. 320 bar
<b>*</b>	<b>E</b> = with manual limiter <b>S</b> = without manual limiter
<b>*</b>	Voltage: <b>F</b> =12V DC <b>G</b> =24V DC
<b>**</b>	Variant (*): <b>S1</b> =No variant <b>SV</b> =Viton <b>CZ</b> =Deutsch connection
<b>1</b>	Serial No.

About pressure range 3 it's suggested to add a modular filter with 5µm cartridge

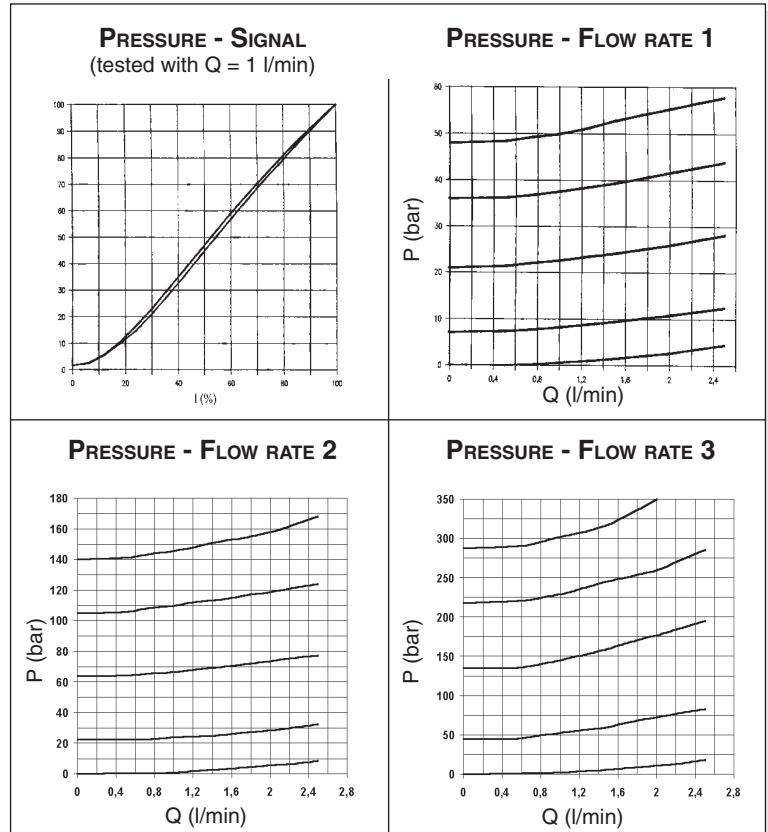

## OVERALL DIMENSIONS

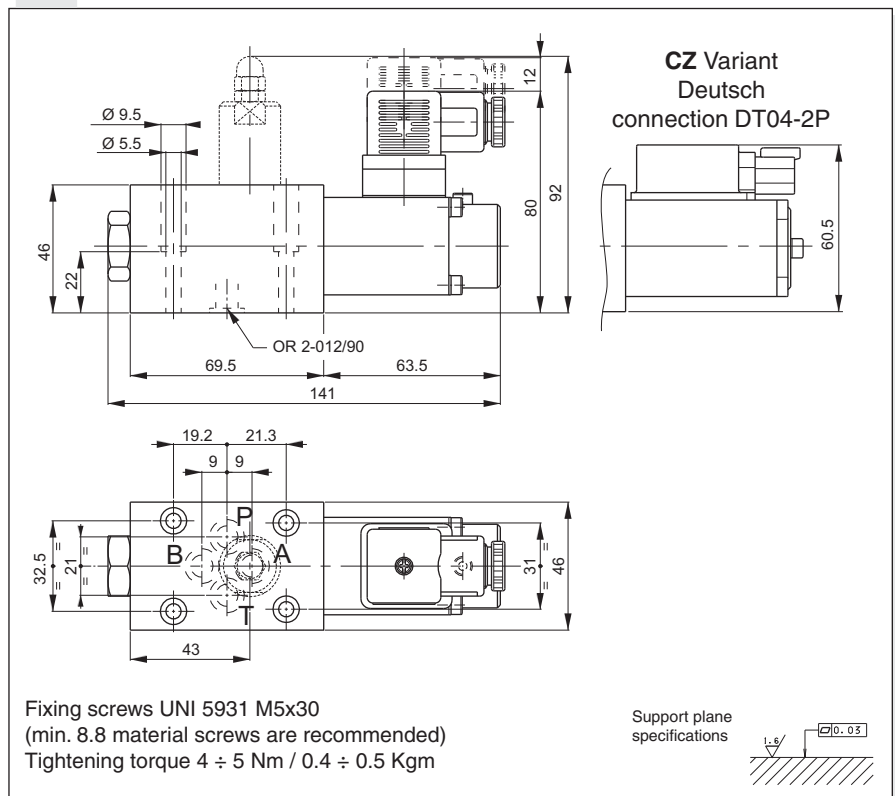

(\*) All variants are considered without connectors. The connectors must be order separately. See Ch. I Page 20

# XP3... PROPORTIONAL PRESSURE CONTROL VALVES CETOP 3

Max. operating pressure (depending on the flow rate)	350 bar
Max. flow	2,5 l/min
Max. ambient temperature	50° C
Linearity	See diagrams
Max. hysteresis	<3% of nominal value
Repeatability error (between 150 and 680 mA)	<2%
Resistance at 20°C (24V)	24.6 Ohm
Resistance at 20°C (12V)	7.2 Ohm
Max. resistance (ambient 20°C) (24V) at op. temp.	31 Ohm
Max. resistance (ambient 20°C) (12V) at op. temp.	9 Ohm
Max. current at (24V)	0.68A
Max. current at (12V)	1.25A
Type of protection	IEC 144 class IP 65
Max. contamination level	class 8 in accordance with NAS 1638 with filter $\beta_{10} \geq 75$
Fluid temperature	-20°C ÷ 75°C
Fluid viscosity	10 ÷ 500 mm <sup>2</sup> /s
Weight	1,4 Kg

• Operating specifications are valid for fluids with 33 mm<sup>2</sup>/s at 50°C, using specified electronic control units.

## ELECTRONIC CONTROL UNITS

### REMSRA\*\*

Card type control for single solenoid 12V and 24V.  
Recommended dither frequency 330 Hz.

TYPICAL INSTALLATION XP3... + VMPE16...

TYPICAL INSTALLATION XP3... + VMPE25...

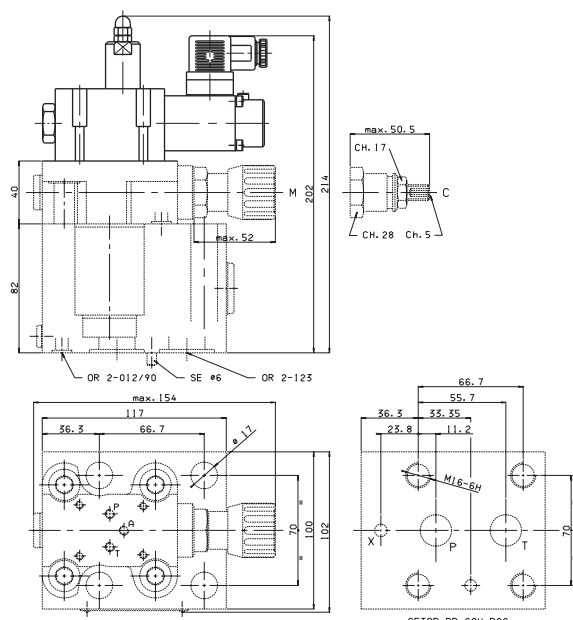
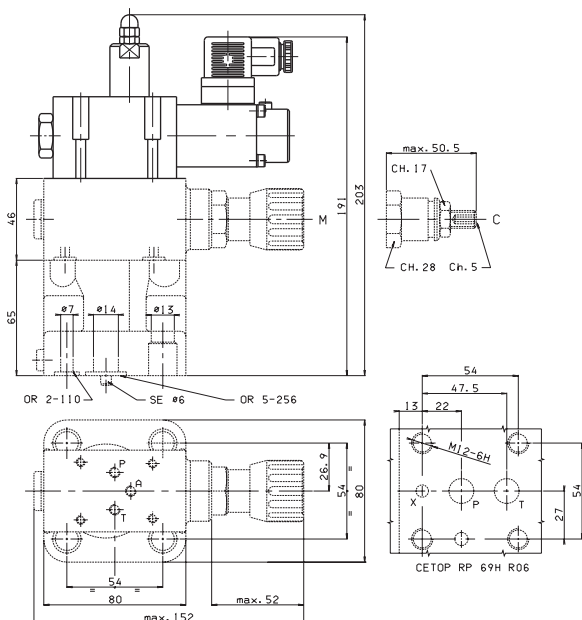

WITH MOUNTING ON VMPE USE THE FOLLOWING CALIBRATED ORIFICES (SEE VMP\*E VALVE AQ VARIANT)

- VMPE16...      A = Ø 1 mm  
                    B = Ø 0,3 mm
- VMPE25...    A = Ø 1,2 mm  
                    B = Ø 0,5 mm

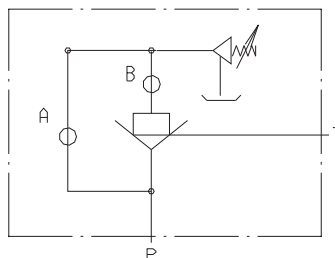

8

# AM3XMP... AMPLIFIER VALVES FOR PROPORTIONAL CONTROL VALVES



AM3XMP...

XP3...

CAP. VIII • 23

Max. operating pressure	320 bar
Max. flow	30 l/min
Min. flow	2 l/min
Max. ambient temperature	50° C
Linearity	See diagrams
Max. hysteresis	<3% of nominal value
Repeatability error (150 ÷ 680 mA) XP3...	<3%
Max contamination level	class 8 in accordance with NAS 1638 with filter $\beta_{10}^{375}$
Fluid temperature	-20°C ÷ 75°C
Fluid viscosity	10 ÷ 500 mm <sup>2</sup> /s
Weight	0,8 Kg

**Operating specifications are valid for fluids with 33 mm<sup>2</sup>/s viscosity at 40° C, using control units**

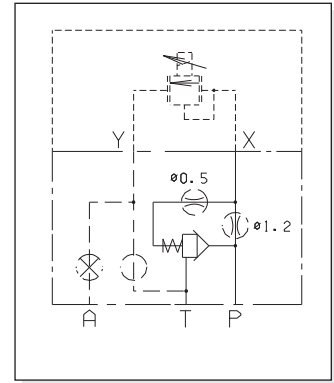

Modular valve type AM.3.XMP.. used together with the pressure proportional pilot type XP3.. becomes a pressure control valve piloted by proportional command for rates up to 30 lt/min. The possibility of external drainage on A ensures its correct operation even with back pressure on the discharge side. Other valves types should be ordered separately.

## ORDERING CODE

- AM** Modular valve
- 3** CETOP 3/NG6
- XMP** maximum proportional pressure
- 2** Spring 2 bar (standard)
- 0** Standard dowels (Ø 1,2 dia supply Ø 0,5 dia damper)
- \*** I = Internal drainage at T  
E = External draining at A
- \*\*** 00 =No variant  
V1 =Viton
- 1** Serial No.

## OVERALL DIMENSIONS

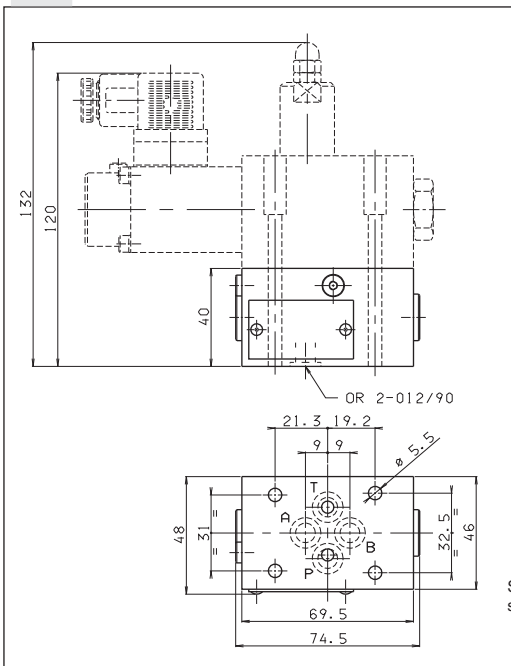

Support plane specifications

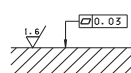

Fixing screws UNI 593 M5x70  
(min. 8.8 material screws are recommended)  
Tightening torque 4 ÷ 5 Nm / 0.4 ÷ 0.5 Kgm

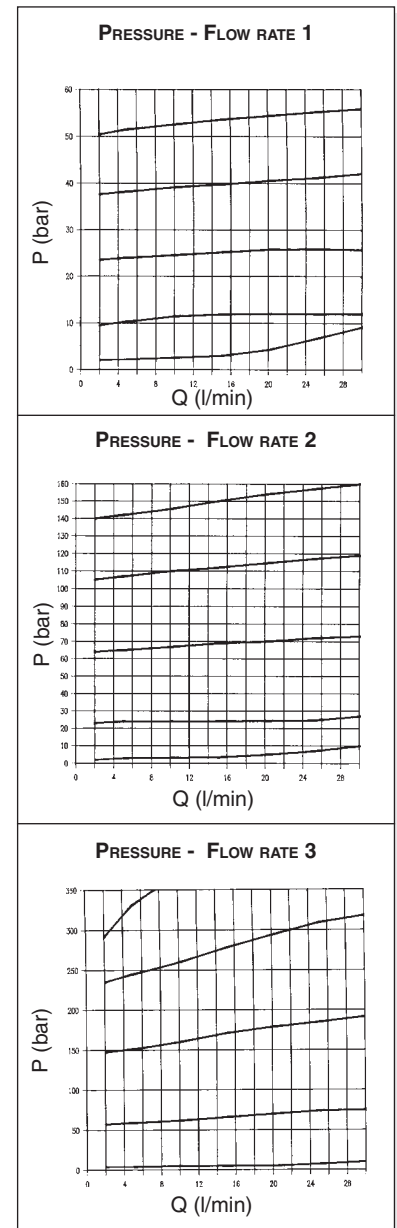
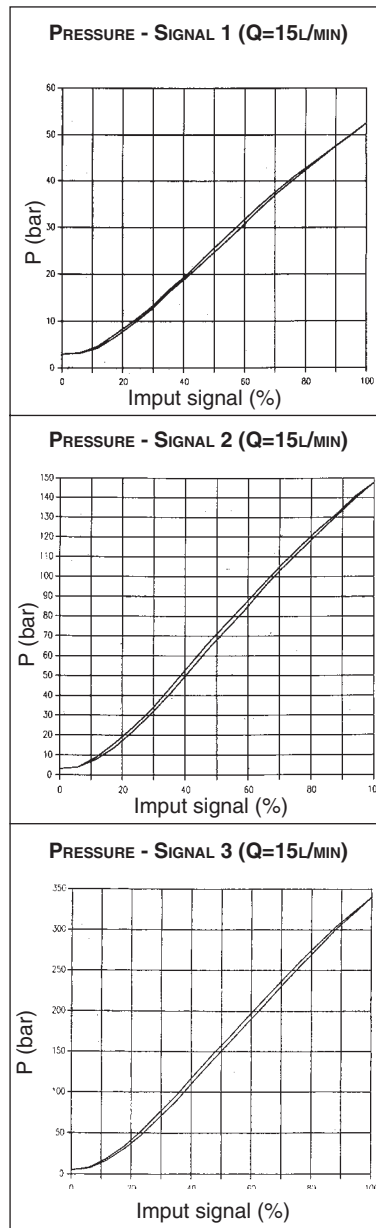



## ABBREVIATIONS

<b>AP</b>	HIGH PRESSURE CONNECTION
<b>AS</b>	PHASE LAG (DEGREES)
<b>BP</b>	LOW PRESSURE CONNECTION
<b>C</b>	STROKE (MM)
<b>CH</b>	ACROSS FLATS
<b>Ch</b>	INTERNAL ACROSS FLATS
<b>DA</b>	AMPLITUDE DECAY (dB)
<b>DP</b>	DIFFERENTIAL PRESSURE (BAR)
<b>F</b>	FORCE (N)
<b>I%</b>	INPUT CURRENT (A)
<b>M</b>	MANOMETER CONNECTION
<b>NG</b>	KNOB TURNS
<b>OR</b>	SEAL RING
<b>P</b>	LOAD PRESSURE (BAR)
<b>PARBAK</b>	PARBAK RING
<b>PL</b>	PARALLEL CONNECTION
<b>Pr</b>	REDUCED PRESSURE (BAR)
<b>Q</b>	FLOW (L/MIN)
<b>QP</b>	PUMP FLOW (L/MIN)
<b>SE</b>	ELASTIC PIN
<b>SF</b>	BALL
<b>SR</b>	SERIES CONNECTION
<b>X</b>	PILOTING
<b>Y</b>	DRAINAGE

## ELECTRONICS



CEPS...	CAP. IX • 2
REMSRA...	CAP. IX • 4
REMDRA...	CAP. IX • 7
SE3AN21RS...	CAP. IX • 11
LAB3	CAP. IX • 13
MAV1152	CAP. IX • 17
MAV1152HY	CAP. IX • 20
MAV4211	CAP. IX • 23
JC3D...	CAP. IX • 26
JC5D...	CAP. IX • 28
JCFD...	CAP. IX • 30

## CEPS.. ELECTRONIC AMPLIFIER PLUG VERSION FOR SINGLE SOLENOID PROPORTIONAL VALVE.



The electronic amplifier Plug version was designed in compliance whit EN 175301-803 (ex DIN43650), for direct mounting on the valve solenoid. The CEP.S can used whit proportional valves XD\*A..., XDP\*A..., XP3..., XQP\*..., CXQ3...

The output stage operates on the pulse width modulation principle (P.W.M.) and is provided with current feedback in order to obtain a solenoid output current proportional to the reference input signal.

Gain, minimum current and rise and fall ramp time adjustments are possible through the corresponding potentiometers fitted on top side of the card, and can be accessed by slackening the relative screw and opening the cover of the connector. While the output current to the solenoid can be measured via the Valve Current test points.

**SERIE 2, has the diode reverse polarity protection inside on the power line.**

### CEPS...

ELECTRICAL SPECIFICATIONS	CAP. IX • 2
OVERALL DIMENSIONS	CAP. IX • 2
FUNCTIONAL BLOCK DIAGRAM	CAP. IX • 3
ELECTRICAL CONNECTIONS	CAP. IX • 3
SETTINGS TOPOGRAPHY	CAP. IX • 3
REFERENCE SIGNAL	CAP. IX • 3

### ORDERING CODE

<b>CEP</b>	Electronic amplifier plug-in version
<b>S</b>	Single solenoid control
<b>RS</b>	Symmetrical ramp
<b>*</b>	Max. output current ( I <sub>max</sub> ) X = 0.88 Amp Y = 1.76 Amp Z = 2.50 Amp
<b>0</b>	Input reference signal 0 ÷ 10V
<b>*</b>	PWM frequency 2 = 400 Hz (per XP3) 3 = 150 Hz (standard)
<b>00</b>	<b>00 = No variant</b> <b>RW = Electrical circuit protected with silicone paint, for more moisture resistance</b>
<b>2</b>	Serial number

### ELECTRICAL SPECIFICATIONS

Power supply	12VDC o 24VDC
Peak supply	40VDC
Minimum power supply	10.5VDC
Required power	30W
Type of protection	IP65
Output current	I <sub>max</sub> = 0.88Amp
All range values are come from the ordering code	I <sub>max</sub> = 1.76Amp I <sub>max</sub> = 2.50Amp
External reference potentiometer	+10V, I <sub>max</sub> =5mA
Input signal reference	0 ÷ 10V
I minimum adjustment	0 ÷ 50% of I <sub>max</sub>
Gain adjustment	30% ÷ 100% of I <sub>max</sub>
Ramp time adjustment	0 ÷ 10 secondi
Operating Ambient temperature	-10C° ÷ +70C°
Current test point	1V = 1Amp
Weight	Kg. 0, 250

### OVERALL DIMENSIONS OF BOX AND CONNECTOR

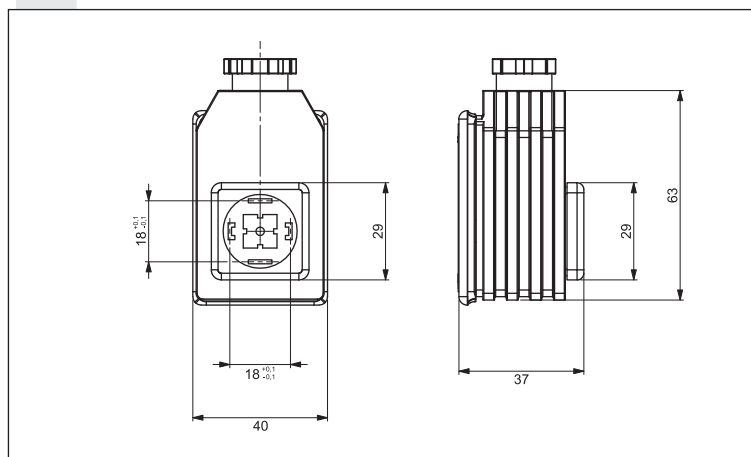

**CE** registered mark for industrial environment with reference to the electromagnetic compatibility. European norms:  
- EN61000-6-2 general safety norm - industrial environment  
- EN61000-6-4 emission general norm - residential environment

• Product in accordance with **RoHS** 2011/65/UE Europe Directive.



# CEPS.. ELECTRONIC AMPLIFIER PLUG VERSION

## FUNCTIONAL BLOCK DIAGRAM

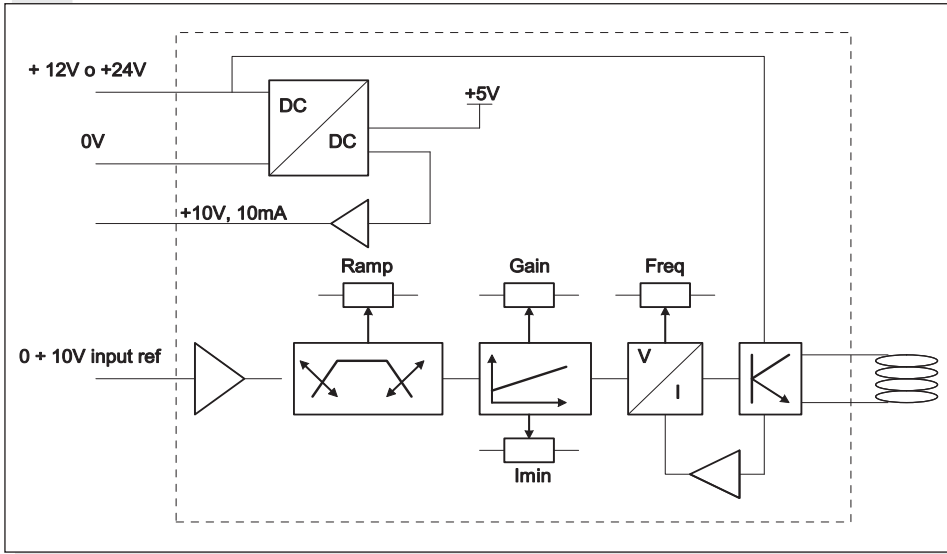

## ELECTRICAL EN 175301-803 CONNECTIONS

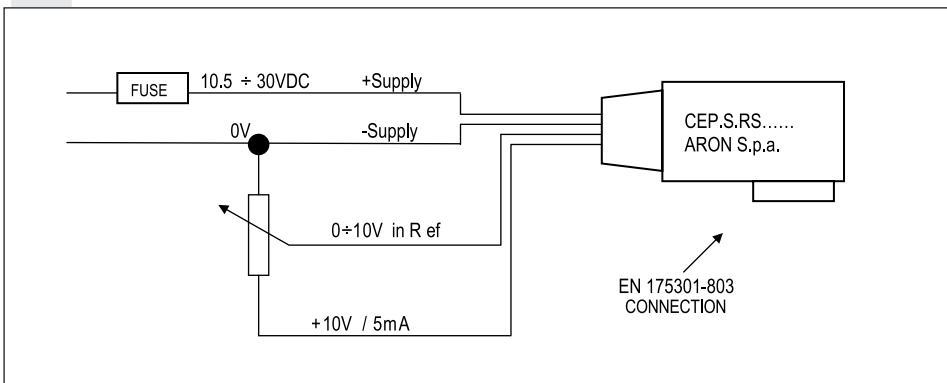

## SETTINGS TOPOGRAPHY

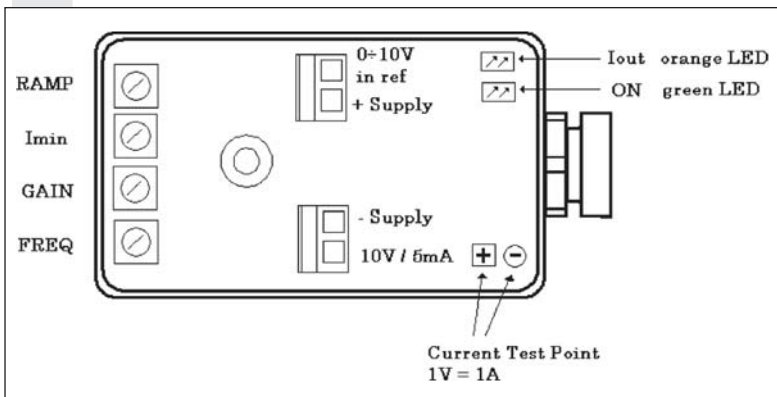

## REFERENCE SIGNAL

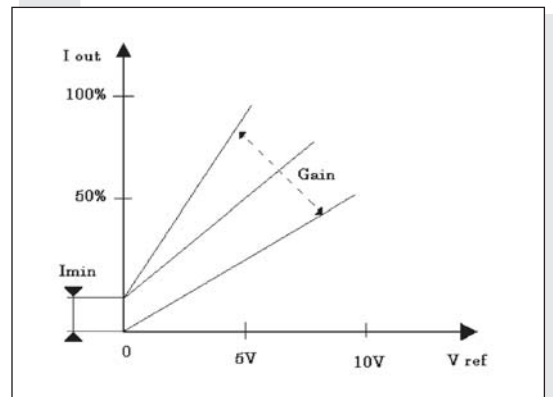

### POWER SUPPLY AND ELECTRICAL CONNECTIONS

The power supply voltage must be rectified and filtered, with a capacitor 4700 uF minimum. **Protect the power supply circuit with 3 A fuse. Respect the polarity supply.** Use the cabling wire with 0.75 mm<sup>2</sup> or 1.0 mm<sup>2</sup> section. In order to facilitate the operation of wires connection, extract the card from the enclosure, introduce the wires through the gland-nut, connect the wires to the clips and finally to lodge the card into the inside of the connector.

Installation and settings, see instruction manual (code P35160008) supplied with the product.

# REMSRA... TYPE ELECTRONIC REGULATORS FOR SINGLE SOLENOID PROPORTIONAL CONTROL VALVES



**REMSRA...**

CALIBRATION PROCEDURE	CAP. IX • 5
OVERALL DIMENSIONS	CAP. IX • 10
MOUNTING BASES	CAP. IX • 10

### ORDERING CODE

<b>REM</b>	Miniaturized electronic regulator in Octal type container
<b>S</b>	Single solenoid
<b>RA</b>	Asymmetrical ramp
<b>*</b>	Maximum output current $I_{MAX}$ . (JU variant) <b>X</b> = 0.88 A (0.80 A) <b>Y</b> = 1.76 A (1.20 A) <b>Z</b> = 2.8 A
<b>*</b>	Input reference (V) see note (*) below <b>2</b> = 0 ÷ + 2 V <b>5</b> = 0 ÷ + 5 V <b>0</b> = 0 ÷ + 10 V <b>A</b> = 0 ÷ 20 mA
<b>*</b>	Frequency Dither <b>1</b> = 100 Hz (standard, JU var.) <b>2</b> = 330 Hz (for XP.3)
<b>*</b>	Minimum initial current <b>G</b> = step (normally for XD.* and XDP.3 valves) <b>C</b> = continuous (normally for XP.3, XQ.3, XQP.* and CXQ.3 valves)
<b>**</b>	<b>00</b> = No variant <b>DJ</b> = Double gain setpoint <b>JU</b> = for MHPF and MSPF electrohydraulics modules (directional valves HPV)
<b>4</b>	Serial No.

(\*) If the input reference is a current signal (mA) the regulator has to be pre-setted in the factory.

• **CE** registered mark for industrial environment with reference to the electromagnetic compatibility. European norms:  
 - EN61000-6-2 general safety norm - industrial environment  
 - EN61000-6-4 emission general norm - residential environment  
 • Product in accordance with **RoHS** 2011/65/UE Europe Directive.

The electronic control card type REM.S.RA has been designed to drive the "XD.\*.A, XDP.3.A, XP.3, XQ.3, XQP.\* and CXQ.3" series single solenoid proportional valves without integral position transducer. The control card is enclosed in an "OCTAL" type housing, a typical relay mounting standard. The output stage operates on the pulse width modulation principle (P.W.M.) and is provided with current feedback in order to obtain a solenoid output current proportional to the reference input signal. Output short circuit and supply polarity inversion protection is provided.

Gain, minimum current and rise and fall ramp time adjustments are possible through the corresponding front panel trimming potentiometers, while the output current to the solenoid can be measured via the Valve Current test points, and the ramp operation can be excluded.

The product incorporates a serial interface for adjustment of parameters.

**Pay attention please: electronic regulators must be used in dampness and water protected places.**

### Manuals and software

The user and installation manual, the manual for variants DJ/JU and the software DG are available on "products" section of [www.brevinifluidpower.com](http://www.brevinifluidpower.com) website (put REMS on internal search engine).

REM. S. RA

#### ADJUSTMENT PANEL

<b>Supply</b>	10VDC ÷ 30VDC (green led)
<b>Overload</b>	Protection against overload (red led)
<b>Ramp off</b>	Ramp off (red led)
<b>Output</b>	Output (current at solenoid, yellow led)
<b>I. min.</b>	Minimum current adjustment
<b>Gain</b>	Gain adjustment
<b>Ramp up</b>	Rump up adjustment time
<b>Ramp down</b>	Rump down adjustment time
<b>Valve Current</b>	Current test point at solenoid (1V = 1A)

If any field is missing from the ordering code the standard setting is as follows:

- Input ref. = 0 ÷ 5V
- Dither 100Hz
- $I_{min}$  = continuous
- $I_{max}$  = 0.8A

### ELECTRICAL CIRCUIT AND CONNECTIONS

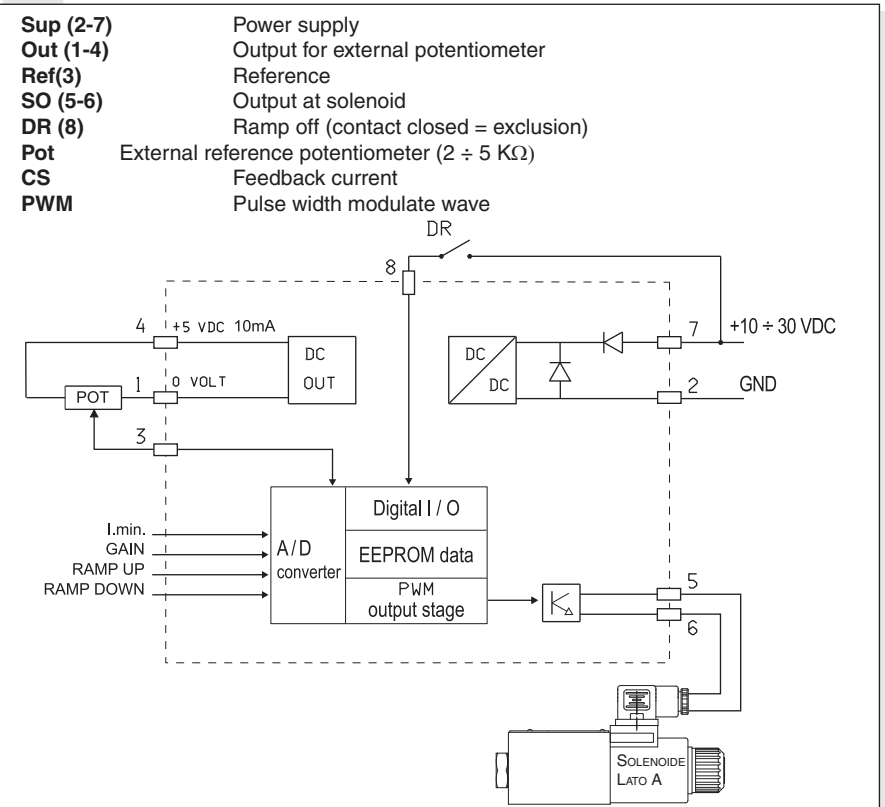

# ELECTRONIC REGULATORS FOR SINGLE SOLENOID PROPORTIONAL CONTROL VALVES

Power supply	10 ÷ 30 VDC
Maximum supply voltage	36 V
Power absorption	40 W
Current output setting by dip switches	I <sub>max</sub> = 2.8A I <sub>max</sub> = 1.76A I <sub>max</sub> = 0.88A
External potentiometer supply output short circuit protected	+5V 10mA
Reference input signal setting by dip switches	0 ÷ +2V 0 ÷ +5V 0 ÷ +10V 0 ÷ 20mA
Polarization current adjustment	I <sub>min</sub> = 0 ÷ 50% I <sub>max</sub>
Current gain adjustment	50% ÷ 100% I <sub>max</sub>
Ramp time adjustment	0 ÷ 20 sec
Ambient operating temperature	-20 ÷ +70°C
Current test point	1 Volt = 1 Ampere
Weight	0.101 Kg

(\*) For the current signal (mA) the regulator has to be pre-setted in the factory.

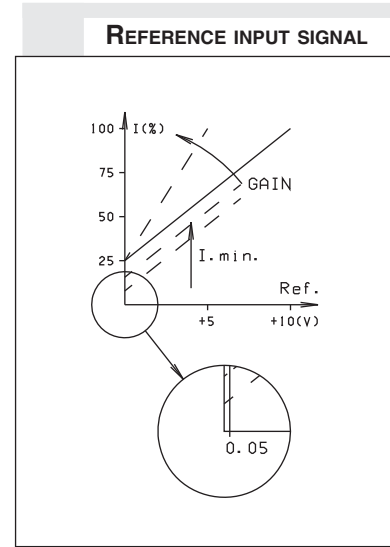

## REMSRA... INSTRUCTIONS FOR USE

### CALIBRATION PROCEDURE

Connect the card in the proper way following the previous page diagram but without powering it or in the way following the next page "Typical connections". Turn completely anticlockwise (20 turns about) the trimming potentiometers of Minimum Current ( $I_{min}$ ) and Ramp Time (Ramp-up and Ramp-down), and position the reference potentiometer on zero. Before powering the card, ensure that any unforeseen hydraulic system movement cannot cause material damage or injury to people. Power now the card; the green LED should light up.

### MINIMUM CURRENT OR POLARIZATION CURRENT ADJUSTMENT

Turn slowly the minimum current trimming potentiometer clockwise ( $I_{min}$ ) until an actuator movement can be visually detected. Turn slowly anticlockwise the potentiometer: the minimum current setting will be adjusted correctly when the actuator movement stops. For the REM model with minimum initial threshold current, set the reference signal to a Vref. of 150 mV.

### MAXIMUM CURRENT GAIN ADJUSTMENT

Turn first the ramp time trimming potentiometers clockwise by at least 10 turns, if the system could be damaged by a too fast solenoid operation (evaluate the application carefully). The maximum actuator speed can now be adjusted. Turn the reference signal to its maximum setting and rotate slowly the GAIN trimming potentiometer (GAIN) until the maximum required speed is obtained. The speed can now be varied by moving the potentiometer.

### RAMP TIME ADJUSTMENT (RAMP-UP E RAMP-DOWN)

The ramp time is the time taken to pass from the minimum to the maximum current value, and vice versa. It's adjustable from a minimum of 0s up to a maximum of 20s (to reach the maximum current value setted). Turning clockwise the trimming potentiometer, the ramp time increases.

### NOTES:

- The ramp fall time affects the actuator stop position. Moving the reference to zero Volt, the actuator goes on moving till the setted ramp time is elapsed. Therefore it's necessary to adjust it properly.
- When the overload red LED lights up, it will be necessary to switch off the power to the card, switching it on again after having eliminated the cause of overload.

# ELECTRONIC REGULATORS FOR SINGLE SOLENOID PROPORTIONAL CONTROL VALVES

## REMSRA... DIP SWITCHES TABLE

For our proportional valves are recommended the following settings:

G	XD3A	DITHER =100Hz	$I_{max}$ = 2.35A with 9V coil
G	XDP3A	DITHER =100Hz	$I_{max}$ = 2.35A with 9V coil
C	XQ3	DITHER =100Hz	$I_{max}$ = 2.35A with 9V coil
C	XQP3	DITHER =100Hz	$I_{max}$ = 2.35A with 9V coil
C	CXQ3	DITHER =100Hz	$I_{max}$ = 2.35A with 9V coil
G	XD2A	DITHER =100Hz	$I_{max}$ = 1.4A with 12V coil
G	XD3A	DITHER =100Hz	$I_{max}$ = 1.76A with 12V coil
G	XDP5A	DITHER =100Hz	$I_{max}$ = 2.5A with 12V coil
G	XDP3A	DITHER =100Hz	$I_{max}$ = 1.76A with 12V coil
C	XQ3	DITHER =100Hz	$I_{max}$ = 1.76A with 12V coil
C	XQP3	DITHER =100Hz	$I_{max}$ = 1.76A with 12V coil
C	XQP5	DITHER =100Hz	$I_{max}$ = 2.5A with 12V coil
C	XP3	DITHER =330Hz	$I_{max}$ = 1.25A with 12V coil
C	CXQ3	DITHER =100Hz	$I_{max}$ = 1.76A with 12V coil
G	XD2A	DITHER =100Hz	$I_{max}$ = 0.7A with 24V coil
G	XD3A	DITHER =100Hz	$I_{max}$ = 0.88A with 24V coil
G	XDP5A	DITHER =100Hz	$I_{max}$ = 1.25A with 24V coil
G	XDP3A	DITHER =100Hz	$I_{max}$ = 0.88A with 24V coil
C	XQ3	DITHER =100Hz	$I_{max}$ = 0.88A with 24V coil
C	XQP3	DITHER =100Hz	$I_{max}$ = 0.88A with 24V coil
C	XQP5	DITHER =100Hz	$I_{max}$ = 1.25A with 24V coil
C	XP3	DITHER =330Hz	$I_{max}$ = 0.68A with 24V coil
C	CXQ3	DITHER =100Hz	$I_{max}$ = 0.88A with 24V coil

Six miniature switches are mounted internally on one of the REM sides. The REM configuration to suit any particular application can be implemented by setting these switches.

PWM frequency (100 to 330 Hz), minimum (continuous or step) current, reference voltage range and maximum current ( $I_{max}$ ) can thus be adjusted.

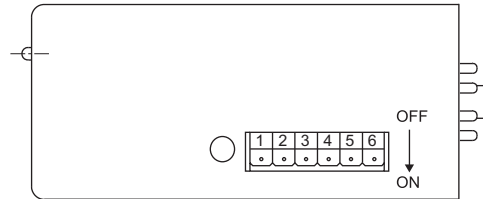

Function	DITHER		I min		Input ref.				I.max.		
	100 Hz	330 Hz	C	G	0÷10 V	0÷5 V	0÷2 V	0÷20 mA	2.8 A	1.76 A	0.88 A
1	OFF	ON									
2			OFF	ON							
3					OFF	ON	OFF	ON			
4					OFF	OFF	ON	OFF			
5									OFF	ON	OFF
6									OFF	OFF	ON

## TYPICAL CONNECTIONS

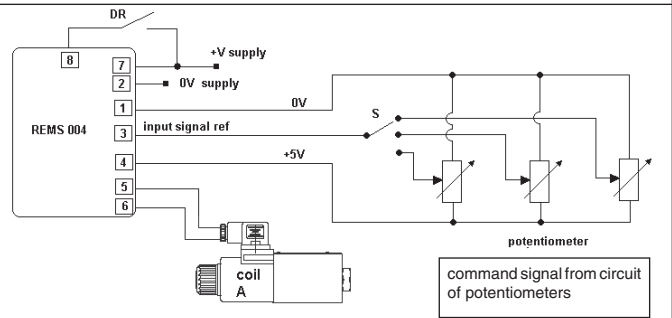
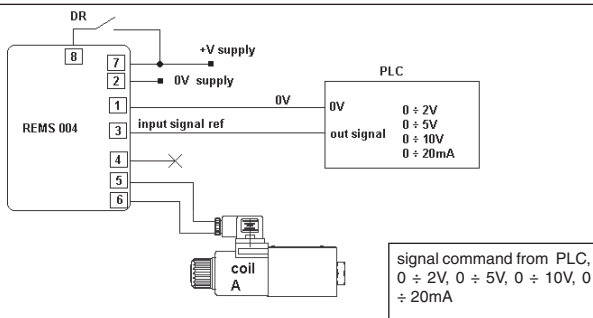
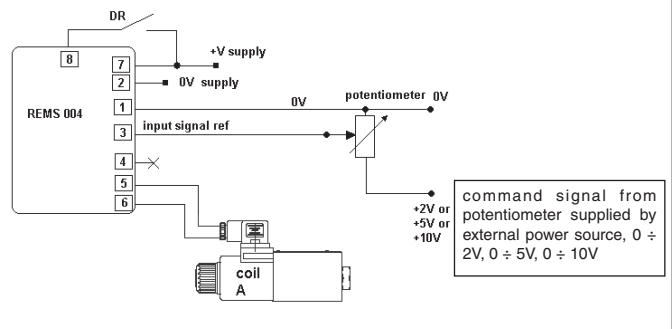
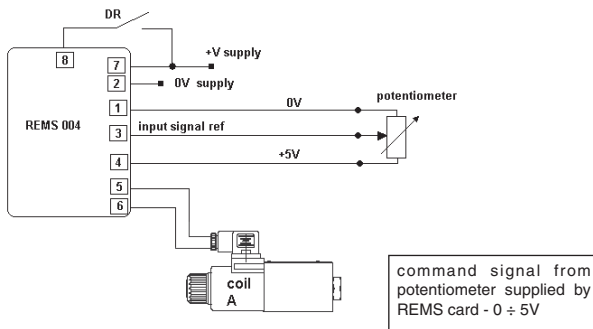

POT = 1000 ÷ 5000 Ω

- The connection between REM and the solenoid must be direct
- The common one of return to proportional solenoid must not be shared between other valve connections or electrical equipment worker.



**REM.D.R.A.**

CALIBRATION PROCEDURE	CAP. IX • 8
OVERALL DIMENSIONS	CAP. IX • 10
MOUNTING BASES	CAP. IX • 10

**ORDERING CODE**

- REM** Miniaturized electronic regulator in Undecal type container
- D** Double solenoid
- RA** Asymmetrical ramp
- \*** Maximum output current  $I_{MAX}$  (JU variant)  
**X** = 0.88 A (0.80 A)  
**Y** = 1.76 A (1.20 A)  
**Z** = 2.8 A
- \*** Input reference (V) see note (\*) below  
**2** = -2 ÷ +2 V  
**5** = -5 ÷ +5 V  
**0** = -10 ÷ +10 V  
**A** = -20mA ÷ +20mA  
**0** ÷ +20mA
- \*** Frequency Dither  
**1** = 100 Hz (standard, JU var.)  
**2** = 330 Hz
- G** Minimum initial current can only be adjusted in steps
- \*\*** **00** = No variant  
**DJ** = Duple setpoint gain  
**JU** = for MHPF and MSPF modules (proportional valves HPV)
- 4** Serial No.

**(\*) If the input reference is a current signal (mA) the regulator has to be pre-setted in the factory.**

• **CE** registered mark for industrial environment with reference to the electromagnetic compatibility. European norms:  
 - EN61000-6-2 general safety norm - industrial environment  
 - EN61000-6-4 emission general norm - residential environment  
 • Product in accordance with **RoHS** 2011/65/UE European Directive.

**REM.D.R.A. TYPE ELECTRONIC REGULATORS**

**DOUBLE SOLENOID PROPORTIONAL CONTROL VALVES**

The electronic control card type REM.D.R.A. has been designed to drive the double solenoid proportional valves series "XD.\*.C..." and "XDP.3.C" without integral position transducer. The control card is enclosed in an "UNDECAL" type housing, a typical relay mounting standard. The output stage operates on the pulse width modulation principle (P.W.M.) and is provided with current feedback in order to obtain a solenoid output current proportional to the reference input signal.

Output short circuit and supply polarity inversion protection is provided. Gain, minimum current and rise and fall ramp time adjustments are possible through the corresponding front panel trimming potentiometers, while the output current to the solenoid can be measured via the Valve Current test points, and the ramps can be excluded.

The product incorporates a serial interface for adjustment of parameters.

**Pay attention please: electronic regulators must be used in dampness and water protected places.**

**Manuals and software**

The user and installation manual, the manual for variants DJ/JU and the software DG are available on "products" section of [www.brevinifluidpower.com](http://www.brevinifluidpower.com) website (put REMD on internal search engine).

	<p><b>Supply</b>  <b>Overload</b>  <b>Ramp off</b>  <b>Output</b>  <b>I. min.</b>  <b>Gain</b>  <b>Ramp up</b>  <b>Ramp down</b>  <b>GND</b>  <b>1VA</b></p>	<p><b>ADJUSTMENT PANNEL</b></p> <p>10Vdc ÷ 30Vdc (green led)        Protection against over (red led)        Ramp off (red led)        Output (current at solenoid A/B, yellow led)        Minimum current adjustment A/B        A/B gain adjustment        A/B ramp up adjustment time        A/B ramp down adjustment time        Ground        Current test point at solenoid</p>
--	--	--

If any field is missing from the ordering code the standard setting is as follows:

- Input ref. = -5 ÷ +5V
- Dither = 100Hz
- $I_{max}$  = 0.8A

**ELECTRICAL CIRCUIT AND CONNECTIONS**

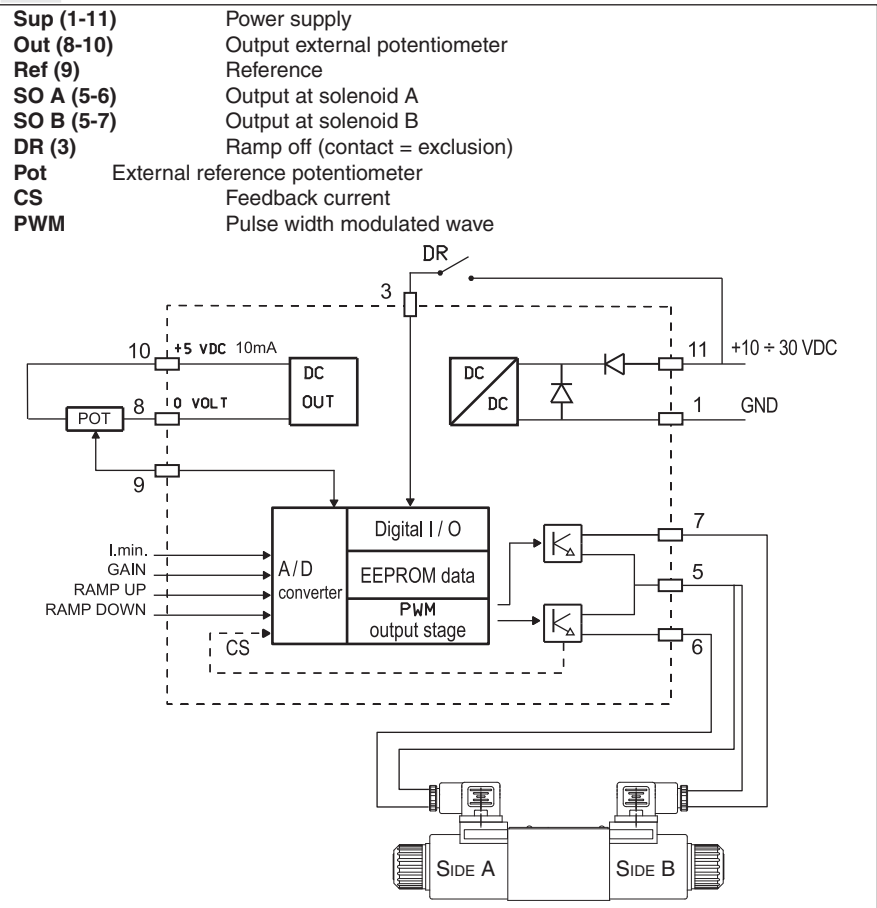

# ELECTRONIC REGULATORS DOUBLE SOLENOID PROPORTIONAL CONTROL VALVES

Power supply	10 ÷ 30 VDC
Maximum supply voltage	36 V
Power absorption	40 W
Current output setting by dip switches	I <sub>max</sub> = 2.8A I <sub>max</sub> = 1.76A I <sub>max</sub> = 0.88A
External potentiometer supply output short circuit protected	+5V I <sub>max</sub> .10mA
Reference input signal setting by dip switches	-2V ÷ +2V -5V ÷ +5V -10V ÷ +10V -20A ÷ +20mA (*)
Signal input reference (pin n° 9) setting by dip switches	0V ÷ +5V 0 ÷ +20mA (*)
Polarization current adjustment	I <sub>min</sub> = 0 ÷ 50% I <sub>max</sub>
Current gain adjustment	50% ÷ 100% I <sub>max</sub>
Ramp time adjustment	0 ÷ 20 sec
Ambient operating temperature	-20 ÷ +70°C
Current test point	1 Volt = 1 Ampere
Weight	0.120 Kg

(\*) For the current signal (mA) the regulator has to be pre-setted in the factory.

## REMDRA... INSTRUCTIONS FOR USE

### CALIBRATION PROCEDURE

Connect the card in the proper way following the next page "Typical connections" but without powering it. Turn completely anticlockwise (20 turns about) the trimming potentiometers of Minimum Current (I<sub>min</sub>) and Ramp Time (Ramp-up and Ramp-down), and position the reference potentiometer on zero. Before powering the card, ensure that any unforeseen hydraulic system movement cannot cause material damage or injury to people. Power now the card; the green LED should light up

### TWO CHANNEL MINIMUM CURRENT (I<sub>min</sub>) ADJUSTMENT (DEAD BAND)

Set the reference signal of approx. V<sub>ref</sub> +150mV. Then turn clockwise the trimmer until an actuator movement can be visually detected (A channel Output LED lights up). Then turn the same trimmer anticlockwise until the movement stops. Repeat the I<sub>min</sub> calibration for the other channel B. Set the reference signal of approx. V<sub>ref</sub> -150mV (B channel Output LED lights up).

### GAIN ADJUSTMENT

Turn first the ramp time trimming potentiometers (RAMP UP) clockwise by at least 10 turns, if the system could be damaged by a too fast solenoid operation (evaluate the application carefully). The maximum actuator speed can now be adjusted. Turn the reference signal to the maximum positive setting value and rotate slowly the gain trimming potentiometer (GAIN) until the maximum required speed is obtained. The speed can now be varied by moving the potentiometer lever. Repeat the above operations for the other channel after turning the reference signal to the maximum negative value.

### RAMP TIME ADJUSTMENT

The ramp time is the time taken to pass from the minimum to the maximum current value, and vice versa. It's adjustable from a minimum of 0s up to a maximum of 20s (to reach the maximum current value setted) separately for channel A and B. Turning clockwise the trimming potentiometer, the ramp time increases.

### NOTES

- 1) The ramp fall time affects the actuator stop position. Moving the reference potentiometer to zero Volt, the actuator goes on moving till the setted ramp time is elapsed. Therefore it's necessary to adjust it properly.
- 2) When the overload red LED lights up, it will be necessary to switch off the power to the card, switching it on again after having eliminated the cause of overload.

### SIGNALS INPUT REFERENCE

The REMD can receive two kinds of command signal inputs, differential input (non inverting, inverting voltage -5V ÷ +5V), or positive voltage (0V ÷ +5V).

### DIFFERENTIAL INPUT REFERENCE

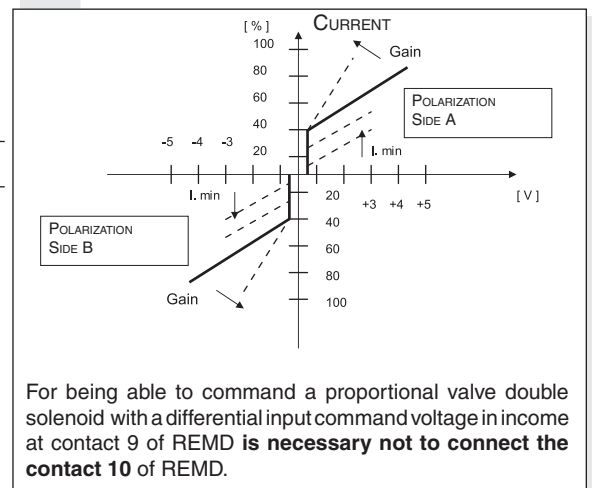

### POSITIVE INPUT REFERENCE

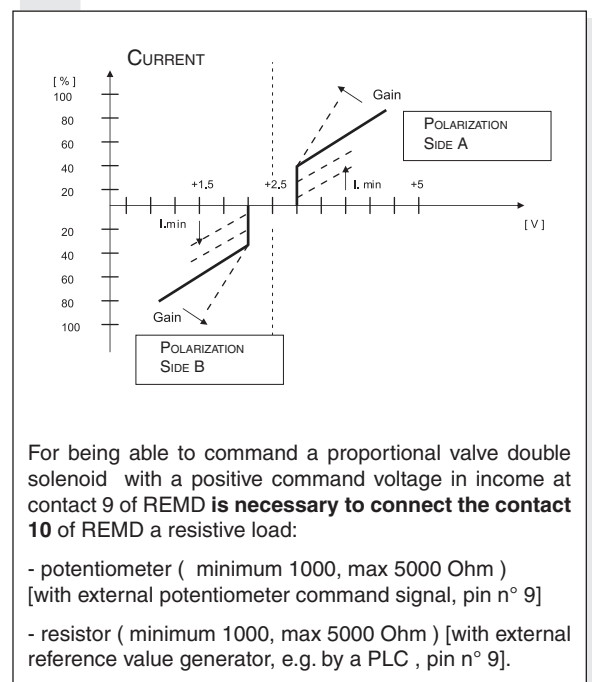

# ELECTRONIC REGULATORS DOUBLE SOLENOID PROPORTIONAL CONTROL VALVES

## REMDRA... DIP SWITCHE TABLE

Six miniature switches are mounted internally on one of the REM sides. The REM configuration to suit any particular application can be implemented by setting these switches. PWM frequency (100 to 330 Hz), reference voltage range and maximum current ( $I_{max}$ ) can thus be adjusted.

For our proportional valves are recommended the following settings:

G	XD3C	DITHER =100Hz	$I_{max}$ = 2.35A with 9V coils
G	XDP3C	DITHER =100Hz	$I_{max}$ = 2.35A with 9V coils
G	XD2C	DITHER =100Hz	$I_{max}$ = 1.4A with 12V coils
G	XD3C	DITHER =100Hz	$I_{max}$ = 1.76A with 12V coils
G	XDP5C	DITHER =100Hz	$I_{max}$ = 2.5A with 12V coils
G	XDP3C	DITHER =100Hz	$I_{max}$ = 1.76A with 12V coils
G	XD2C	DITHER =100Hz	$I_{max}$ = 0.7A with 24V coils
G	XD3C	DITHER =100Hz	$I_{max}$ = 0.88A with 24V coils
G	XDP5C	DITHER =100Hz	$I_{max}$ = 1.25A with 24V coils
G	XDP3C	DITHER =100Hz	$I_{max}$ = 0.88A with 24V coils

For the version with reference signal in current it needs to be preset in-factory.

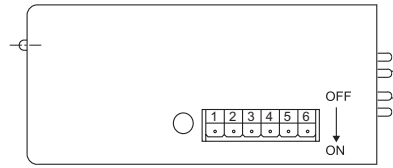

Function	DITHER	I min	Input ref.					I.max.				
DIP sw	100 Hz	330 Hz	G	-10÷10 V	-5÷5 V	-2÷2 V	-20mA ÷20mA	0÷5 V	0 ÷20mA	2.8 A	1.76 A	0.88 A
1	OFF	ON										
2			ON									
3				OFF	ON	OFF	ON	ON	ON			
4				OFF	OFF	ON	OFF	OFF	OFF			
5										OFF	ON	OFF
6										OFF	OFF	ON

## TYPICAL CONNECTIONS

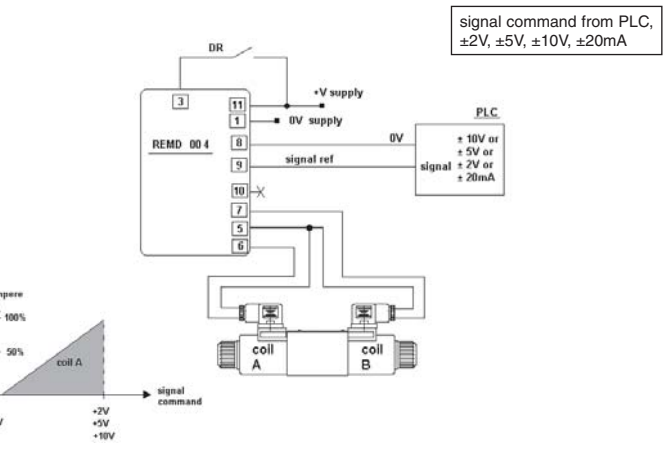
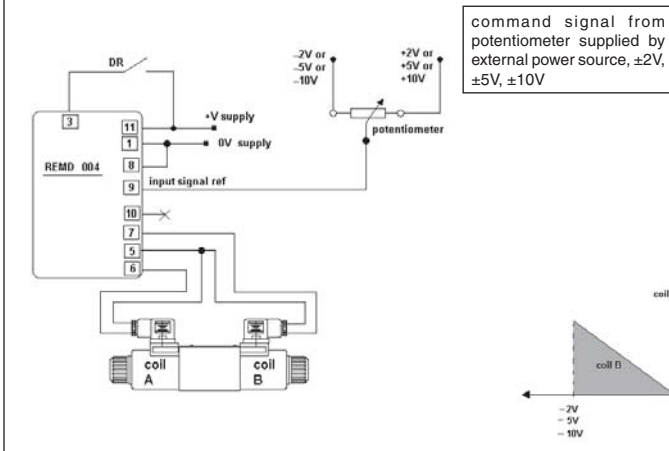
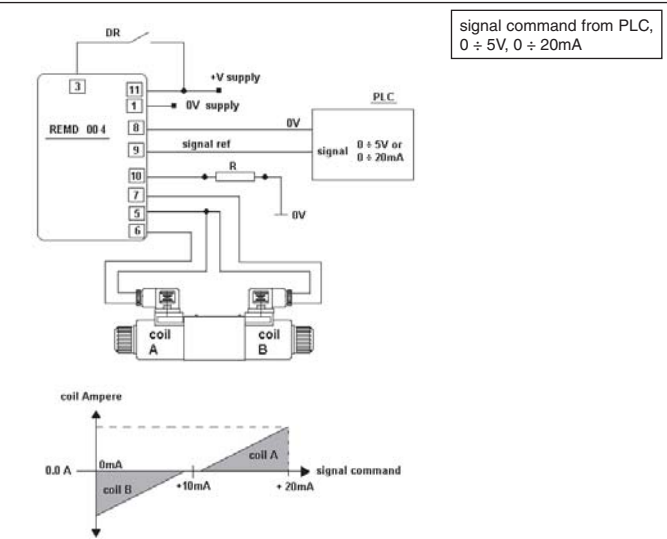
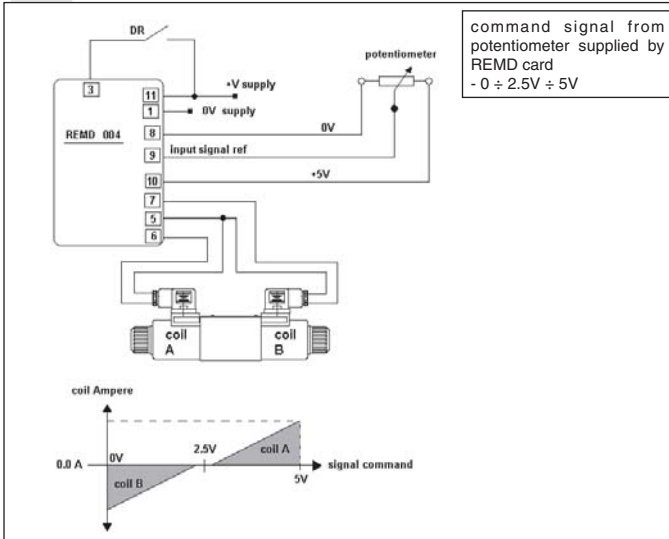

- The connection between REM and the solenoid must be direct
- The common one of return to proportional solenoid must not be shared between other valve connections or electrical equipment worker.

$R = 1000 \div 5000 \Omega$   
 $POT = 1000 \div 5000 \Omega$

# REMS/DRA... TYPE ELECTRONIC REGULATORS

## SINGLE / DOUBLE SOLENOID PROPORTIONAL CONTROL VALVES

### OVERALL DIMENSION AND MOUNTING BASES ON DIN GUIDES FOR REMSRA...

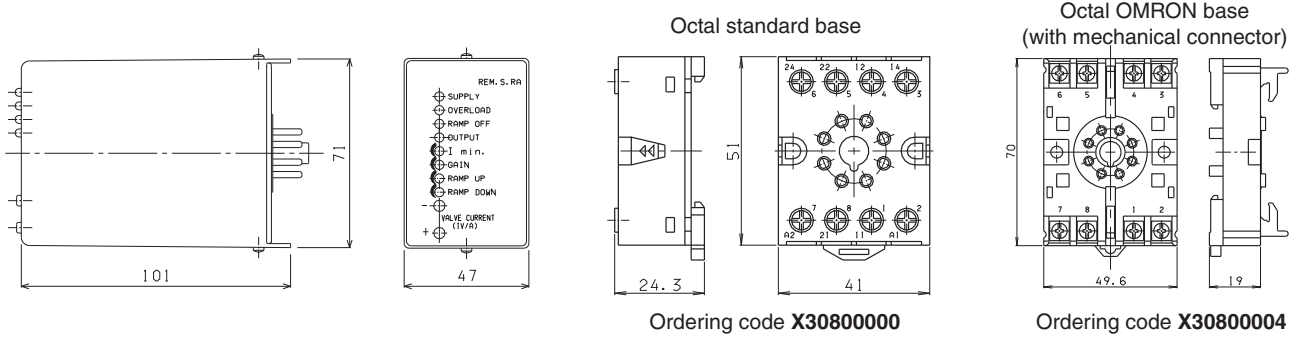

### OVERALL DIMENSION AND MOUNTING BASES ON DIN GUIDES FOR REMDRA...

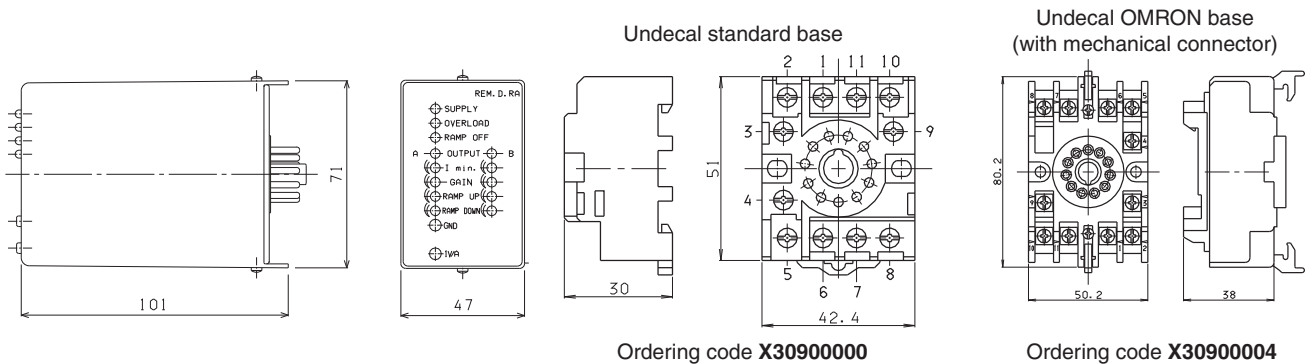

### DG SOFTWARE

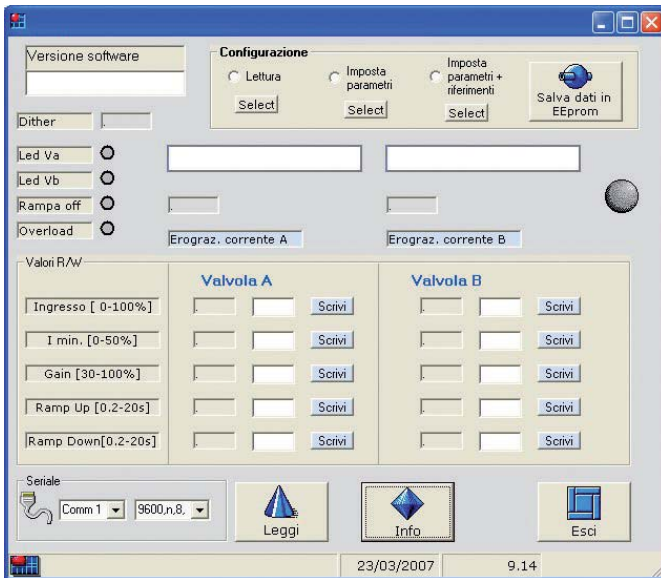

DG program for the digital adjustment of the parameters of the REMS and REMD boards.

DG program for the digital adjustment of the parameters of the REMS and REMD boards.

The program is used to store (the settings are cancelled when the REM board is switched off) the following parameters:

- Minimum current
- Upward current ramp
- Upward current ramp
- Downward current ramp

Italian/English version: purchase order code **P35150003**.

NB: the DG software can be used with all the REMS and REMD boards that have a TTL connector (production commencement year 2008).

### SERIAL CABLE RS232/TTL



Ordering code **VE0110001**



REM connecting at computer with serial cable.



# SE3AN21RS... ELECTRONIC CARDS FORMAT EUROCARD FOR POSITIONAL TRANSDUCER VALVES CONTROL



**SE3AN21RS...03**

INSTRUCTIONS CAP. IX • 12  
OVERALL DIMENSIONS CAP. IX • 12

The electronic cards type SE3AN21RS...serie 3 have been planned for controlling single and double solenoid proportional valves XDC3....serie 2 equipped with position transducer type LVDT. The card has a EUROCARD format for being assembled on a connector type DIN 41612 D 32. The output stage operates on the basis of the Pulse Width Modulation (PWM) and is subject to the current feedback so that it is possible to obtain an output solenoid current directly proportional to the input signal. The regulator is supplied with standard calibration for proportional valve control. The card is equipped with a control module type PI which compares the reference signal with the position transducer signal: the eventual error is used to optimize the regulation. It is possible to carry out further regulations by operating on the relative trimmers placed on the frontal panel (see picture).

- The connection between the card and the solenoid must be direct
- The common one of return to proportional solenoid must not be shared between other valve connections or electrical equipment worker.



Registered mark with reference to the electromagnetic compatibility.

European norms: EN50082-1 - General safety norm; EN50081-1 -Emission general norm.

## ORDERING CODE

<b>SE</b>	Electronic card format EUROCARD DIN 41612
<b>3</b>	NG06
<b>AN21</b>	Analogic
<b>RS</b>	Closed loop valves with positional transducer type XDC3 .... serie 2
<b>16</b>	Max. current at solenoid: 1.76 A
<b>0</b>	No variant
<b>3</b>	Serial No.

## ADJUSTMENT PANEL FOR CARD

<b>Fault</b>	red – transducer fault signal
<b>Power on</b>	yellow – 24V DC power supply
<b>Enable</b>	green – card enable
<b>Gain A</b>	Solenoid A maximum current regulation
<b>Offset A</b>	Solenoid A offset current regulation
<b>Gain B</b>	Solenoid B maximum current regulation
<b>Offset B</b>	Solenoid B offset current regulation
<b>Ramp Up</b>	Ramp up regulation
<b>Ramp Down</b>	Ramp down regulation
<b>Current A</b>	Solenoid A current test point (1V=1A)
<b>Current B</b>	Solenoid B current test point (1V=1A)
<b>Reference</b>	Reference signal test point
<b>Transducer</b>	Transducer signal measurement point
<b>Common 0V</b>	Common zero

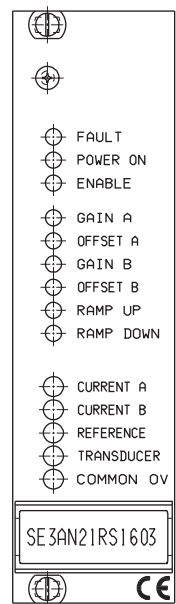

## ELECTRICAL CIRCUIT AND CONNECTIONS

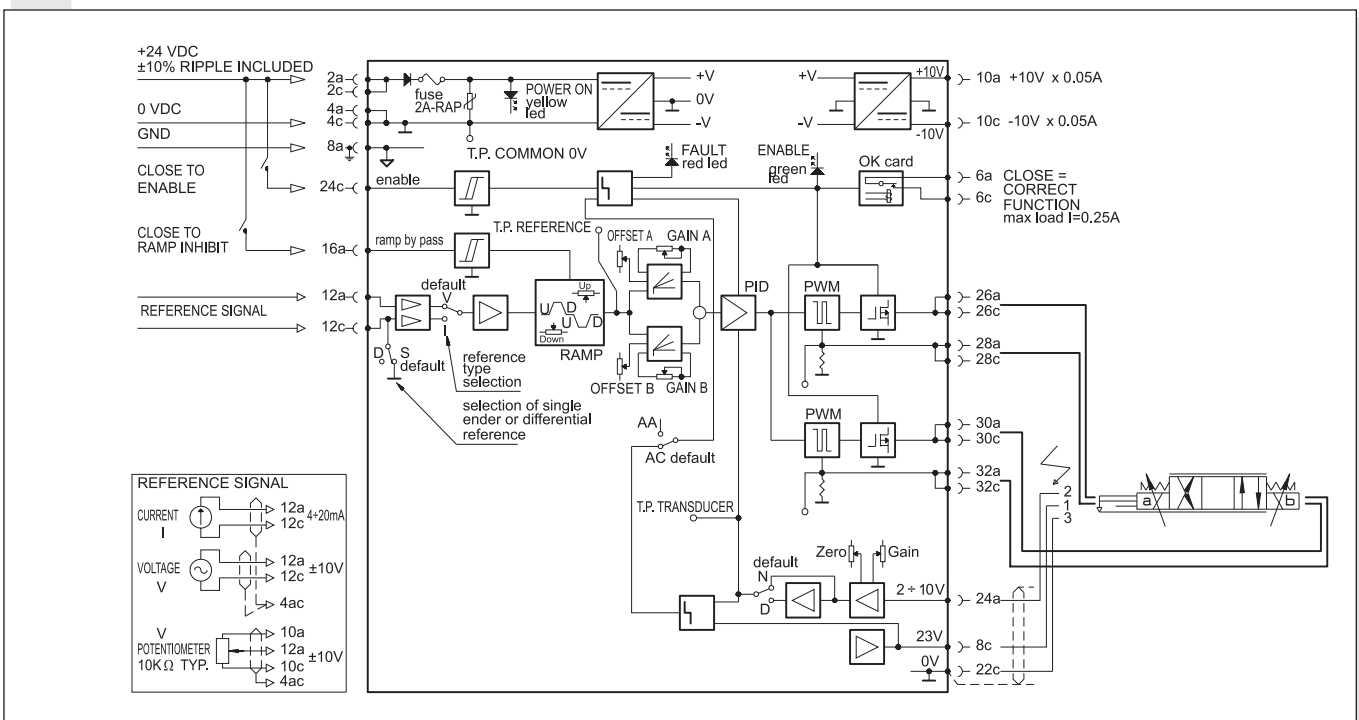

# SE3AN21RS... ELECTRONIC CARDS FORMAT EUROCARD FOR POSITIONAL TRANSDUCER VALVES CONTROL

## Instructions for use

For proportional valves with code  
XDC3C..F... serie 2 (SE3AN21RS16...serie 3)

## Power electric supply

24 VDC nominal  
22÷30 VDC rectified and stabilized (30W max.)  
2A fast-acting fuse is fitted for power circuit protection.

## Reference voltage

The card gives 2 stabilized voltage values: +10V 50mA (a10) and -10V 50mA (c10).

## Available inputs

± 10V (a12, c12) presetted  
4 ÷ 20mA (a12, c12) move SW 1 bank in "I" position

## Card enable (Enable)

Usually the card is not enable. For enabling it, apply in c24 a voltage between 22 and 30VDC. Green led signal.

## Ramp exclusion

Ramps are usually on. In order to disable them apply a16 a voltage between 22 ÷ 30VDC.

## Calibration procedure

Connect the card according to the scheme (See the preceding page). Set zero the reference potentiometer. Before applying the voltage, make sure that the hydraulic system does not move suddenly causing damages to people or things. Apply the voltage to the card: the green led will start blinking. Enable the card and disconnect the ramps (led "FAULT" off) and disable the ramps.

## Minimum current regulation

**A channel:** put the reference signal on 3÷5% of the max. value. Turn the minimum current trimmer clockwise ( $I_{min}$  A) until the actuator moves; then turn the trimmer counterclockwise until the actuator stops.

**B channel:** repeat the above procedure for the A channel by operating on the  $I_{min}$  B trimmer for negative values of the reference signal.

## Maximum current regulation

**A channel:** put the reference signal on the max. (positive) value and turn the gain trimmer ( $I_{max}$  A) slowly, until the max. speed requested is reached. Now the speed can be varied by changing the reference signal.

**B channel:** repeat the above procedure for the A channel by operating on the  $I_{max}$  B trimmer and by putting the reference signal on the max. negative value.

## Ramp time calibration

Connect the ramps. The ramp time is the time which is necessary for going from the minimum current value to the max. current value and vice versa. The time can be set from a minimum value of 0.1 sec. (ramp excluded) up to a maximum value of 10 sec. (valve max. opening) whether downwards or upwards. By turning the trimmers clockwise the ramp time increases.

## Notes:

The ramp down time influences the lock position of the actuator. By setting to zero the reference signal, the actuator keeps moving until the ramp time set (in a downward direction) has passed. For this reason it is necessary to carry out the adjustment carefully and properly.

The card block (FAULT) is automatically reset after that the error has been eliminated.

## LVDT connection

See the preceding page:

- terminal 1 della LVDT c8 of the card
  - terminal 2 della LVDT a24 of the card
  - terminal 3 della LVDT c22 of the card
- Use screened cable with earth braid.

## Solenoid current test point

On the frontal card panel: 1V = 1A

## Command signal test point

Enables reading in voltage of referencesignal sent to the card.

Reading is direct, but of opposite sign, with voltage reference while current conversation is: 4mA = +10V, 20mA = -10V.

## Feedback signal test point

On the frontal card panel: ± 5V according to the spool position

## Ambient temperature range

0° ÷ 50°C

## Electric connections

The connections concerning the reference potentiometers must be carried out with a wire having a section of  $\geq 0.75\text{mm}^2$ .

It is advised to use a screened cable with earth braid.

9

## OVERALL DIMENSIONS

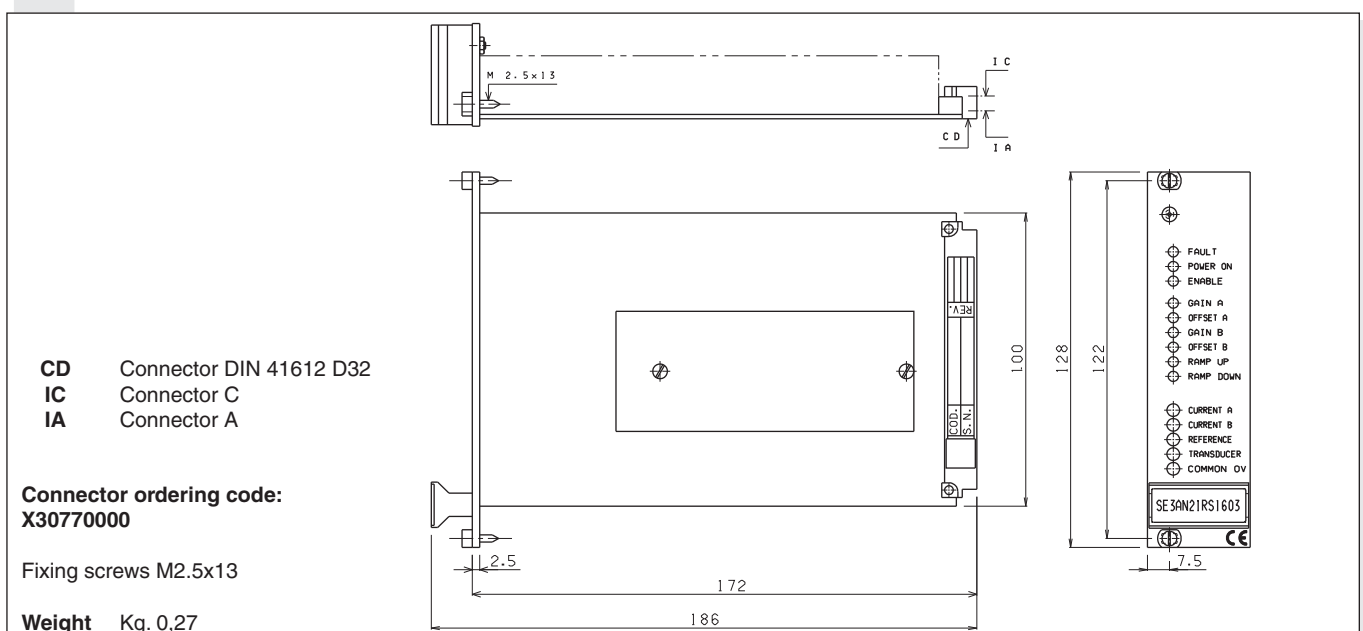

## LAB3 SELF LEVELLING DEVICE FOR AERIAL PLATFORMS

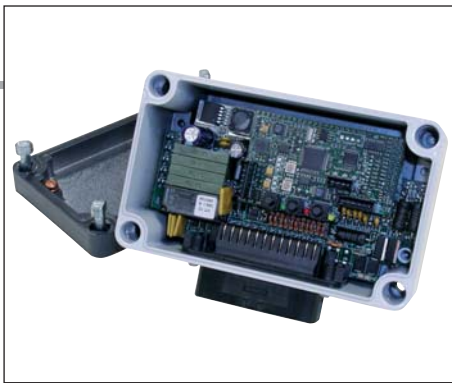

The Self levelling Device LAB3 meets the safety requirements:

- Category 3 (EN954-1)
- PL d (EN13849-1)

The card has two outputs PWM current feedback to control a proportional valve, a safety relay output to stop the movements, two digital output signal basket inclination, when exceeds 6°.

The optimization of working parameters can be easily done via serial connection and user interface software BPE\_Terminal.

Using BPE terminal can make the alignment of the zero level of the LAB3 with the zero tilt basket, set the minimum current to the proportional levelling valve, the current gain, change the operating angle of the two current outputs for the alert of 6° exceeding basket tilt, and finally adjust the width of the dead zone in correspondence of the zero grade requirements

EMC conformity 2004/108/CE

- EN61000-6-2
- EN61000-6-3

### LAB3

DIMENSIONI DI INGOMBRO	CAP. IX • 13
LED AND CONNECTORS LAYOUT	CAP. IX • 14
MAIN CONNECTOR	CAP. IX • 14
ELECTRICAL CONNECTIONS	CAP. IX • 15
MOUNTING EXAMPLE	CAP. IX • 16

### ORDERING CODE

Code	Description
7.365.1186	Self Levelling Device for aerial platforms
7.003.055	Connector AMP seal 35 pole
7.045.068	Serial cable RS232 LAB3 , 4mt length
www.bpe.it	BPE Terminal software downloaded from www.bpe.it website

Included in the furniture:

- Installation and use manual

Power supply	9 ÷ 33V
Proportional PWM output	current feedback, max load 3A
PWM frequency	4000 Hz
Dither frequency	100 Hz
Vertical position dead band	Yes
Coils current offset adjustment	Yes
Coils current gain adjustment	Yes
Output of safety relay to stops dangerous movements (10° of tilt basket, or device failure)	Max load 2Ampere
Two independent On/off current outputs (switch on at 6° tilt basket)	Max load 1Ampere
Serial link RS232	YES-for adjustment work parameters
Working ambient temperature	-40 ÷ +70 °C
Main connector	AMP seal 35 pole
Protection degree	IP66

### OVERALL DIMENSIONS

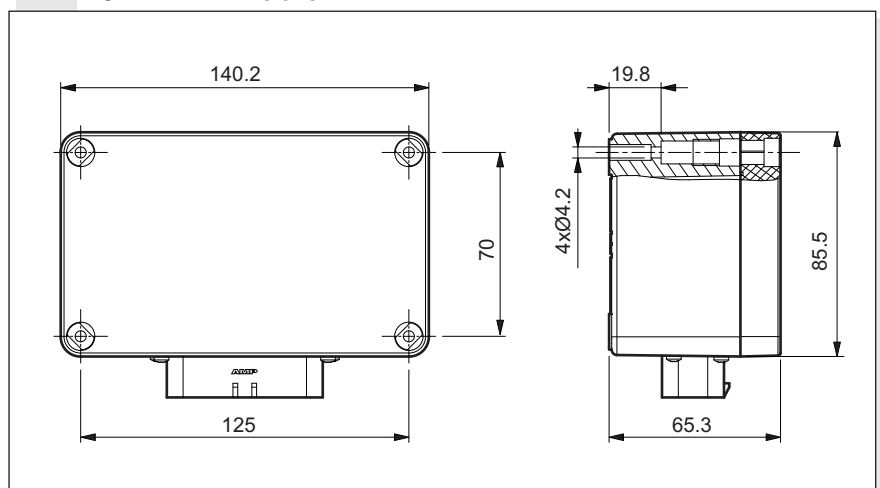

# SELF LEVELLING DEVICE FOR AERIAL PLATFORMS

## LED AND CONNECTORS LAYOUT

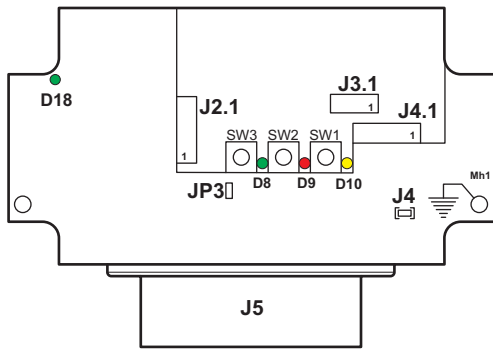

### Conn. Description

J5	Main connector AMP seal 35 poli
J3.1	Inside connector for RS232 communication with (BPE Terminal software)
J2.1	Reserved
J4.1	Reserved
D18	Status of power on
D8	Show the status error codes of LAB3 (green)
D9	Show the status error codes of LAB3 (red)
D10	Show the status error codes of LAB3 (yellow)
SW1	Push button, for self calibrating procedures
SW2	Push button, for self calibrating procedures
SW3	Push button, for self calibrating procedures

## MAIN CONNECTOR (WIRING DETAILS)

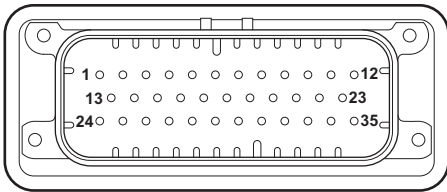

Pin	Function	Note
1	Positiv Supply Voltage	Connects to battery positive
2	Negativ Supply Voltage	Connects to battery negative
3	Output of safety relay to stops dangerous movements (10° of tilt basket, or device failure)	Maximum load 2 Ampere
4	Input of safety relay to stops dangerous movements (10° of tilt basket, or device failure)	Connects to battery positive
24	Output PWM - coil A	Maximum current 3 Ampere
25	Output PWM - coil B	Maximum current 3 Ampere
26	Return of coils A and B	
28	On/off current output (switch on at 6° tilt basket)	Maximum load 1 Ampere
29	On/off current output (switch on at 6° tilt basket)	Maximum load 1 Ampere

### ELECTRICAL CIRCUIT

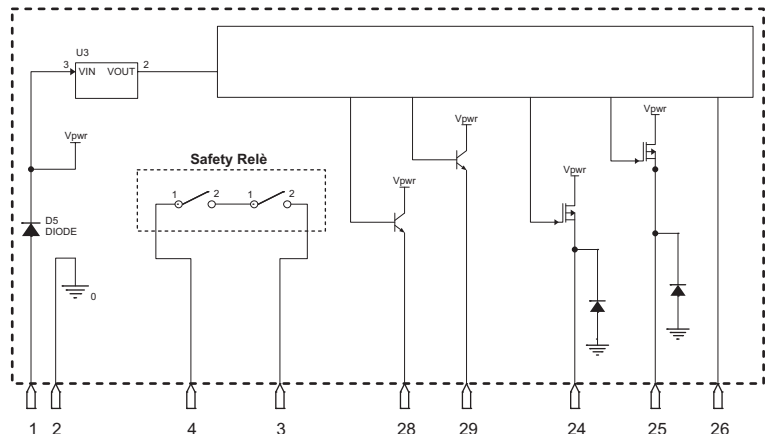

## ELECTRICAL CONNECTIONS

### LAB3 connection examples to replace the model SE3LN33240804 and SE3LN33121604

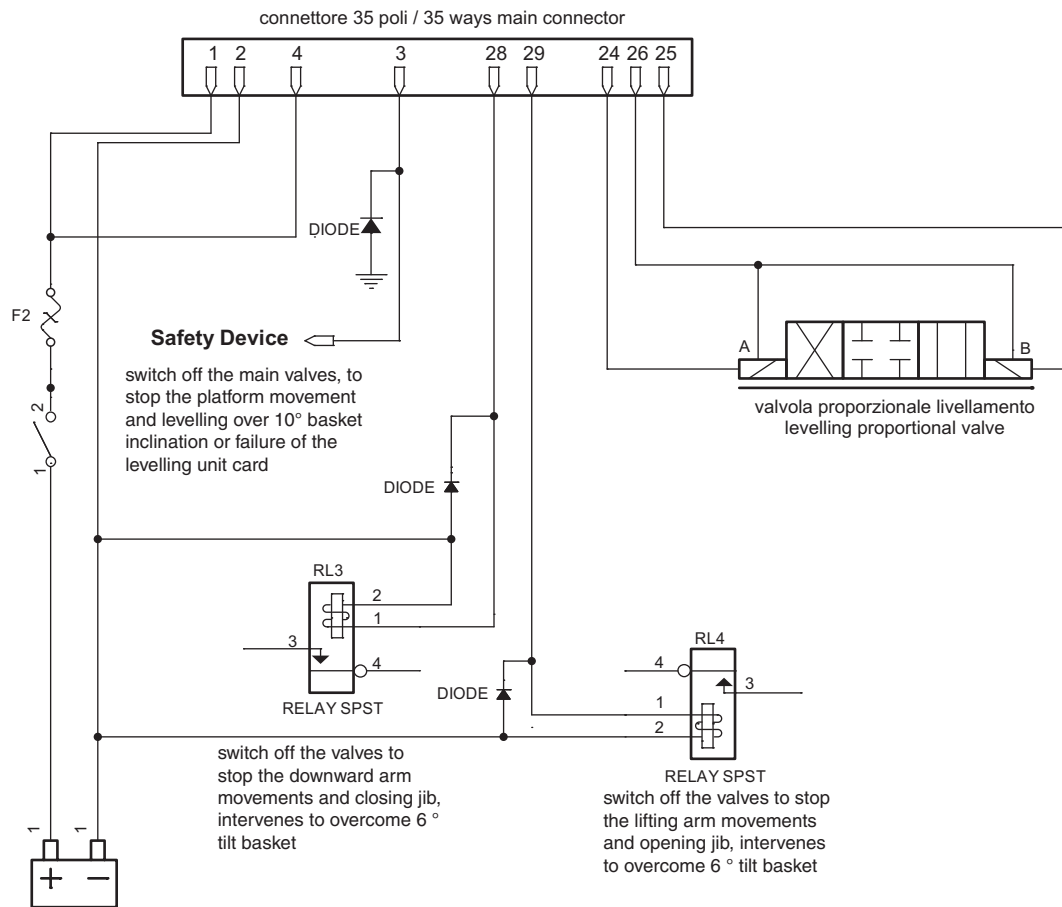
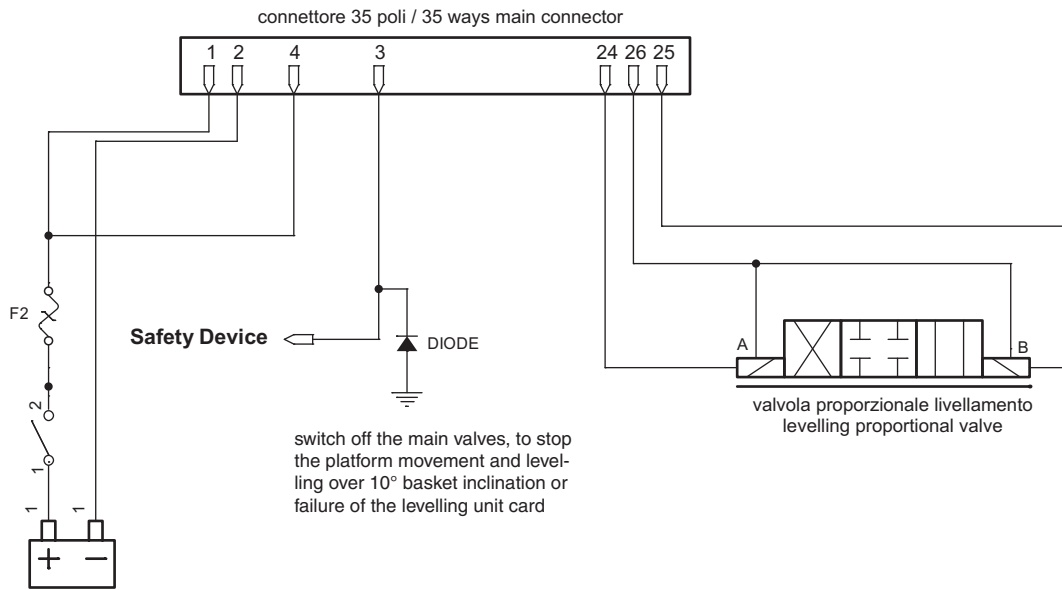

**Connection only for example Before proceeding with the calibration on the machine, read the use and installation manual.**

# SELF LEVELLING DEVICE FOR AERIAL PLATFORMS

## MOUNTING EXAMPLE

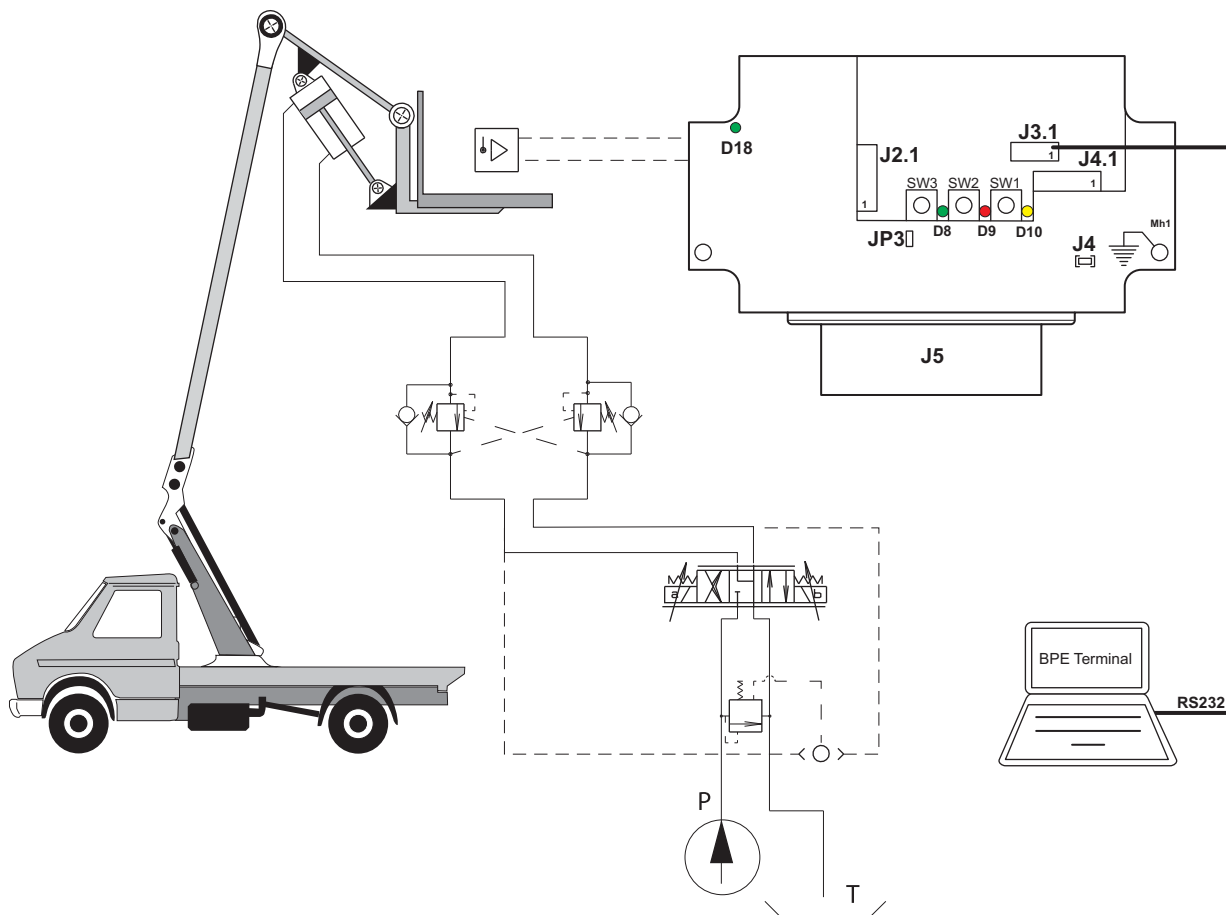

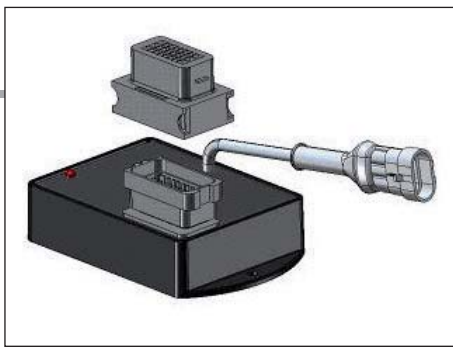

## MAV1152 ELECTRONIC MODULE FOR INTEGRATED CONTROL OF ONE PROPORTIONAL AND ON/OFF DIRECTIONAL VALVES

The MAV1152 controller unit is used for the control of one proportional solenoids and additional switching valves. The proportional solenoid output is pulse-width-modulated (PWM) and optimally adapted for electric proportional control of Dana Brevini products. The switched outputs are designed for the direct switching of on/off solenoids, relays, and lamps. The MAV unit can managed up to 5 analog input signal and 1 PWM current output + 5x2 switched outputs ( max load 9Amperes ).

The RS232 serial interface and BPE software tool enables the connection of PC for service functions, such as diagnostics, parameter setting or display of process variables.

European norms: EN 61000-6-2, EN61000-6-3, ElectroMagnetic Compatibility (EMC) - industrial environment

### MAV1152

LAYOUT	CAP. IX • 18
ELECTRICAL CONNECTIONS	CAP. IX • 18
OVERALL DIMENSIONS	CAP. IX • 18
MOUNTING EXAMPLE	CAP. IX • 19

#### Optional (on request):

- CANbus port communication;
- on/off output for venting valve on CAT 3 safety

#### Adjustment parameters by RS232 link :

Frequency PWM  
 Offset current  
 Gain current  
 Ramp up time current  
 Ramp down time current  
 Analog input configuration (voltage 0.5 ÷ 4.5V, 1 ÷ 9V, current 4 ÷ 20mA).

### ORDERING CODE

Code	Description
7.365.1162	MAV1152 electronic module for integrated control of one proportional and on/off directional valves
www.bpe.it	BPE Terminal software downloaded from www.bpe.it website

### SPECIFICATIONS:

Nominal voltage		12V and 24V
Operating supply voltage		9 ÷ 33Vdc
Current consumption	With load, max	9A
Protection Fuse	Only external	Rapid fuse 10A
Constant voltage source	For joystick supply	5V
Analog input Selectable by serial link	Voltage	0.5 ÷ 4.5V
	Voltage	1 ÷ 9V
	Current	4 ÷ 20mA
Switch input	High or low active	Low < 1.5V; high > 6V
Proportional PWM output		0 ÷ 2A
PWM frequency range		70Hz ÷ 250Hz
On/off output (mosfet)		3A
Led indicator		Green/red/yellow
Interfaces		RS232
Number of analog input		5
Number of switch input		2 (standard)
Number of PWM output		1
Number on/off output	For directional valve	10
	For venting valve	1
Protection against short circuit	Input and output	Yes
Reverse connect protection	Power supply	Yes
Operating temperature		-40 ÷ 70°C
IP protection	With mounted mating connector	IP67
Mating connector	FCI - SICMA	24 pole

MAV product must be used with joysticks JCFD1GG1 output signal 10-90% or similar.



Plug-in connector 24 poles FCI - SICMA (to be ordered separately)

Code	Description
7.003.054	Connector
7.180.403	Connector with 1 mt. cable length

# MAV1152 ELECTRONIC MODULE

## LAYOUT

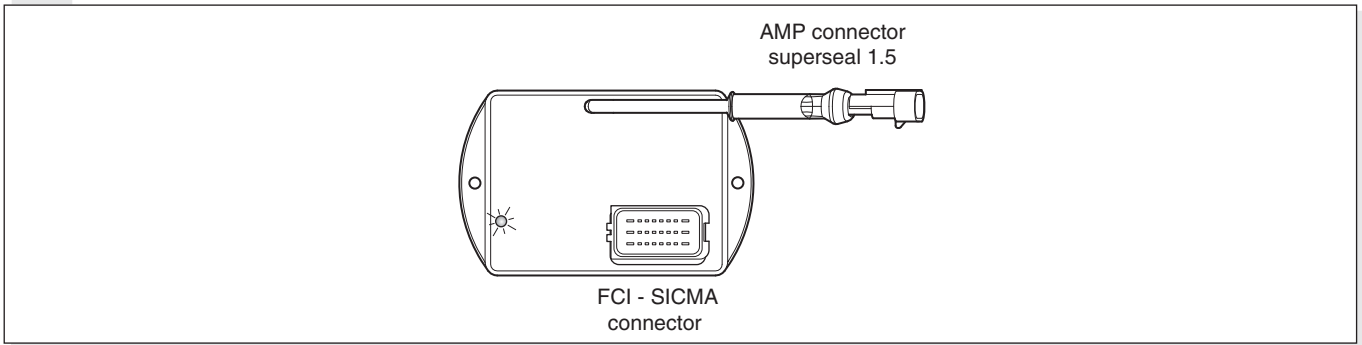

## ELECTRICAL CONNECTIONS

Contacts description: Mating Connector FCI - SICMA

PIN	8	7	6	5	4	3	2	1
<b>A</b>	O1A	Venting OUT	O2A	O3B	PWM return	O5B	O5A	+ Supply
<b>B</b>	O2B	0V	+5V output	AN2	AN1	IN3	PWM out	O1B
<b>C</b>	O3A	AN5	AN4	O4A	O4B	AN3	IN4	- Supply

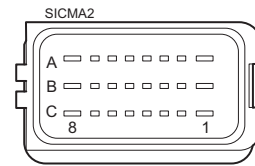

AN = analog input,  
IN = digital input,  
O1A ... O(5)A = on/off output for valve 1 ... (5) coil A  
O1B ... O(5)B = on/off output for valve 1 ... (5) coil B

### Connection example:

Proportional single solenoid valve

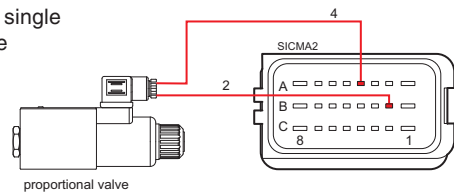

Serial Link RS232 connector : AMP superseal 1.5

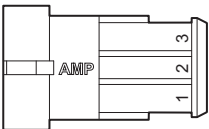

PIN 1	PIN 2	PIN 3
GND	RX	TX

Directional on/off valve

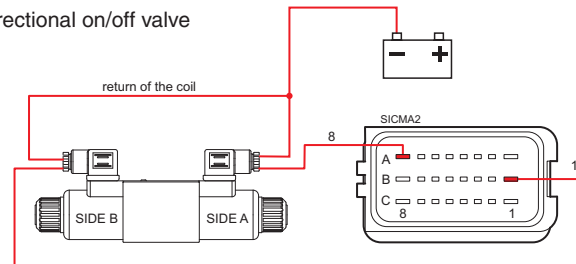

JCFD1GG1 fingertip joystick

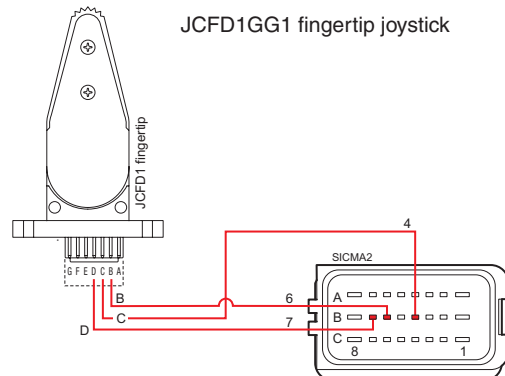

## OVERALL DIMENSIONS

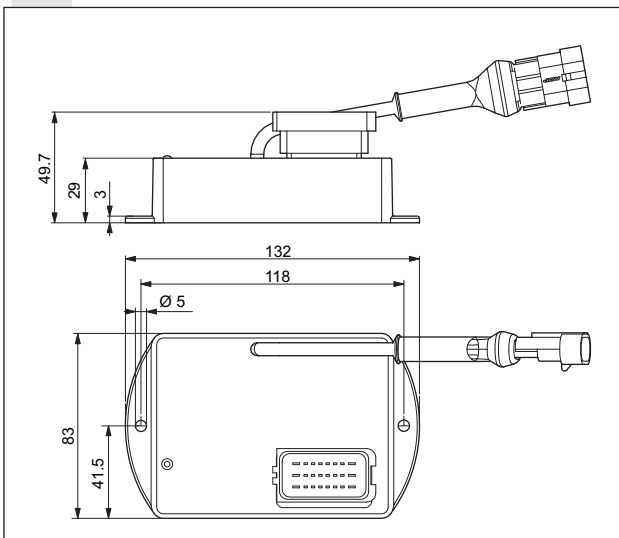



## MOUNTING EXAMPLE WITH DANA BREVINI PRODUCTS



Proportional fingertip levers

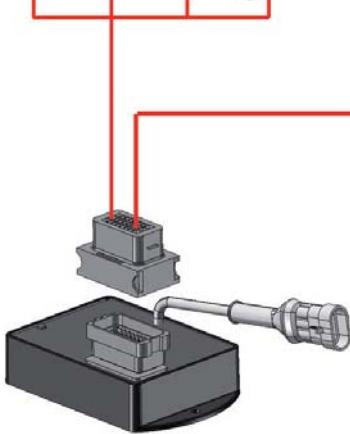

1 proporzional valve and 5 on/off valves

**NOTE:** MAV product must be used with joysticks JCFD1GG1 output signal 10-90% or similar.



**VERSION WITH STACKABLE VALVES**

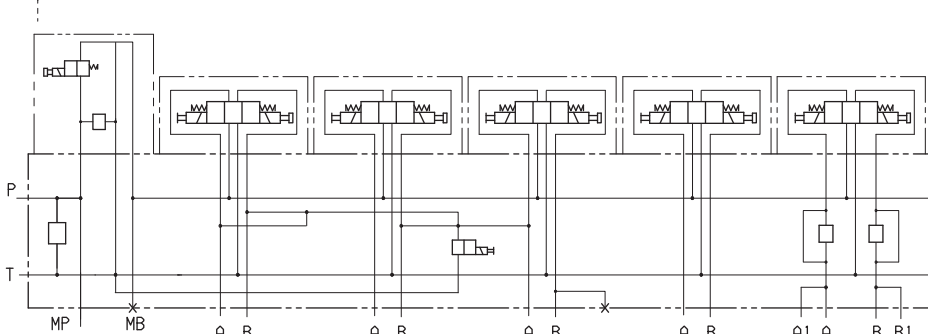
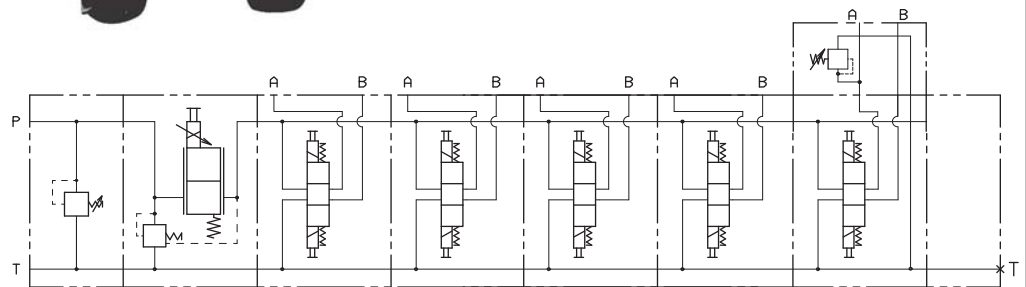

**VERSION WITH CETOP 3 OR CETOP 5 VALVES**

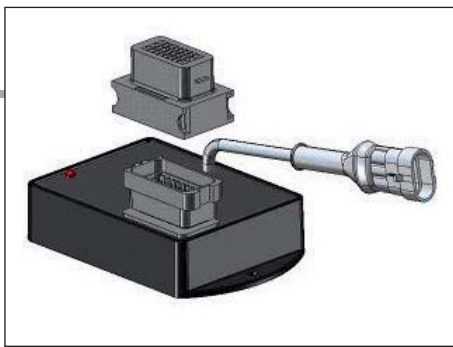

## MAV1152HY ELECTRONIC MODULE FOR INTEGRATED CONTROL OF PROPORTIONAL AND ON/OFF VALVES FOR JOYSTICK

The MAV1152HY controller unit is used for the control of one proportional solenoids and additional switching valves. The proportional solenoid output is pulse-width-modulated (PWM) and optimally adapted for electric proportional control of Dana Brevini products. The switched outputs are designed for the direct switching of on/off solenoids, relays, and lamps. The MAV unit can managed 1 PWM current output and 5x2 switched outputs + venting valve (max load 9Amperes).

The RS232 serial interface and BPE software tool enables the connection of PC for service functions, such as diagnostics, parameter setting or display of process variables.

European norms: EN 61000-6-2, EN61000-6-3, ElectroMagnetic Compatibility (EMC) - industrial environment

### MAV1152HY

LAYOUT	CAP. IX • 21
OVERALL DIMENSIONS	CAP. IX • 21
ELECTRICAL CONNECTIONS	CAP. IX • 21
BPE-TERMINAL SOFTWARE	CAP. IX • 21
ELECTRICAL CONNECTION	CAP. IX • 22
MOUNTING EXAMPLE	CAP. IX • 22

### Optional (on request):

- CANbus port communication;
- on/off output for venting valve on CAT 3 safety

### Adjustment parameters by RS232 link :

Frequency PWM  
Offset current  
Gain current  
Ramp up time current  
Ramp down time current  
Analog input configuration (voltage 0.5 ÷ 4.5V, 1 ÷ 9V, current 4 ÷ 20mA).

### ORDERING CODE

Code	Description
7.365.1187	MAV1152HY electronic module for integrated control of proportional and on/off valves for Dana Bevini Joystick
www.bpe.it	BPE Terminal software downloaded from www.bpe.it website

### SPECIFICATIONS:

Nominal voltage		12V and 24V
Operating supply voltage		9 ÷ 33Vdc
Current consumption	Max	9A
Protection Fuse	External	Rapid fuse 10A
Constant voltage source	For joystick supply	5V
Analog input Selectable by serial link	Voltage	0 ÷ 5V
	Voltage	0 ÷ 10V
	Current	0 ÷ 20mA
Switch input	High or low active	Low < 1.5V; high > 6V
Proportional PWM output		0 ÷ 2A
PWM frequency range		70Hz ÷ 250Hz
On/off output (mosfet)		3A
Led indicator		Green/red/yellow
Interfaces		RS232 and ( optional as a request CAN 2.0B)
Number of analog input		1
Number of switch input		6
Number of PWM output		1
Number on/off output		5x2
Switch output for venting valve (3A)	CAT3 safety (PLd) (optional as a request)	1
Protection against short circuit	Input and output	Yes
Reverse connect protection	Power supply	Yes
Operating temperature		-40 ÷ 70°C
IP protection	With mounted mating connector	IP67
Mating connector	FCI - SICMA	24 pole

9



Plug-in connector 24 poles FCI - SICMA (to be ordered separately)

Code	Description
7.003.054	Connector
7.180.403	Connector with 1 mt. cable length

### Default settings:

- Analog input signal: 0 ÷ 5V
- PWM frequency: 150 Hz
- Min. current PWM output: 400mA
- Max. current PWM output: 1700mA

# MAV1152HY ELECTRONIC MODULE

## LAYOUT

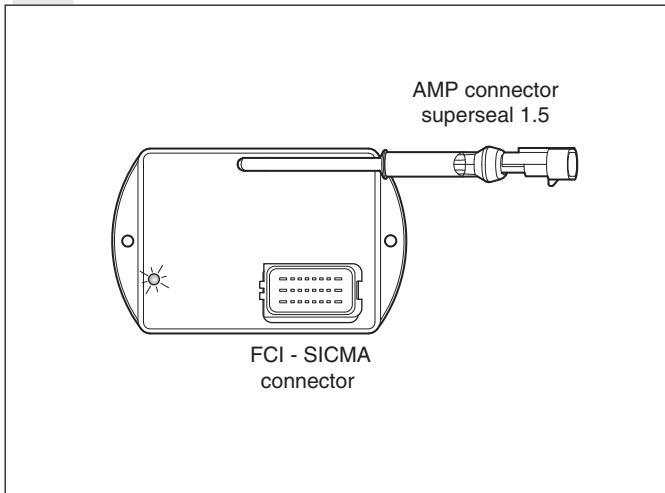

## OVERALL DIMENSIONS

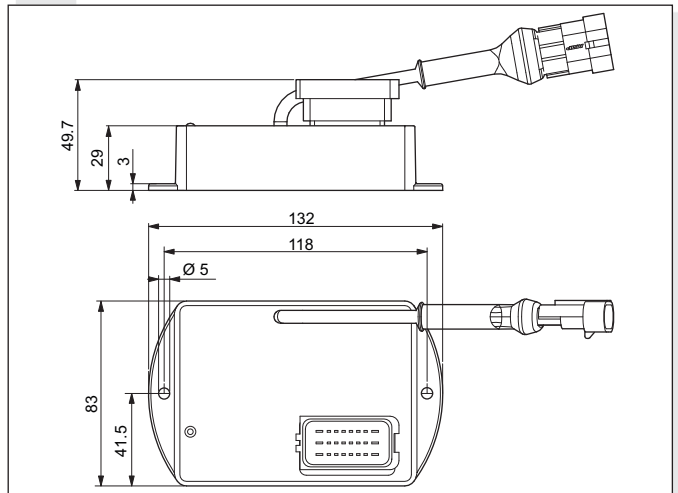

## ELECTRICAL CONNECTIONS

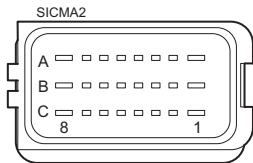

Contacts description: Mating Connector FCI - SICMA

PIN	8	7	6	5	4	3	2	1
A	O1A	Venting OUT	O2A	O3B	PWM re-turn	O5B	O5A	+ Supply
B	O2B	0V	+5V output	IN5	AN1	IN3	PWM out	O1B
C	O3A	IN8	IN7	O4A	O4B	IN6	IN4	- Supply

PIN	Description	Connects to:
B4	AN1	Y signal track of joystick
B5	IN5	Push button n°2 of the joystick
C3	IN6	Push button n°3 of the joystick
C6	IN7	Push button n°4 of the joystick
C7	IN8	Push button n°5 of the joystick
B3	IN3	Push button n°1 of the joystick
C2	IN4	Dead man switch joystick
B6	+5V output	Analogue supply track of the joystick

AN = analog input,  
IN = digital input,  
O1A = on/off output 1 coil A directional valve  
O1B = on/off output 1 coil B directional valve

Serial Link RS232 connector : AMP superseal 1.5

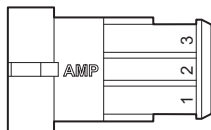

PIN 1	PIN 2	PIN 3
GND	RX	TX

## BPE-TERMINAL SOFTWARE

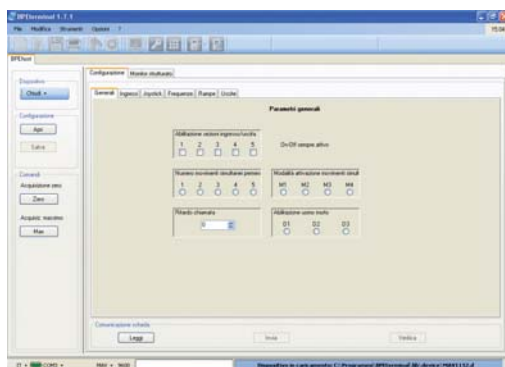

### Software - BPE-Termial

The BPE terminal software, allows to set the MAV. Furthermore with BPE terminal is possible to set all the work parameters, minimum current, maximum current, PWM frequency...

The BPE Terminal software is free downloadable from BPE website [www.bpe.it](http://www.bpe.it)

# MAV1152HY ELECTRONIC MODULE

## ELECTRICAL CONNECTIONS

### Y axis Analogue track connections JC5 and MAV

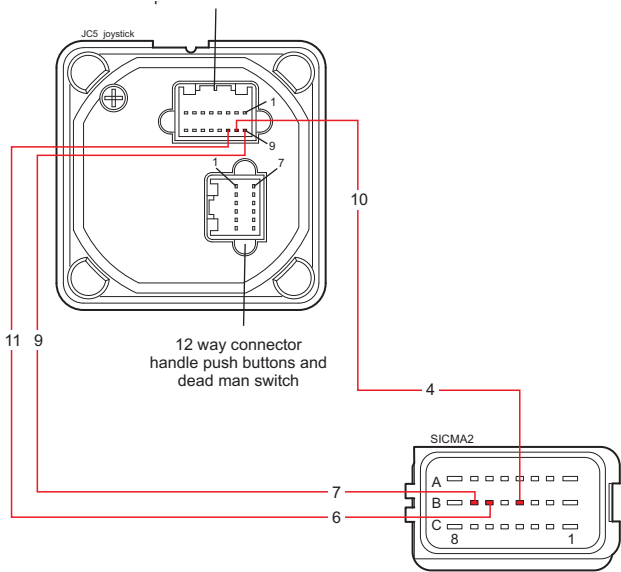

PIN Joy.	Connect to MAV
1	B7
9	B4
10	B6
11	B6

### Dead man switch and push buttons connections

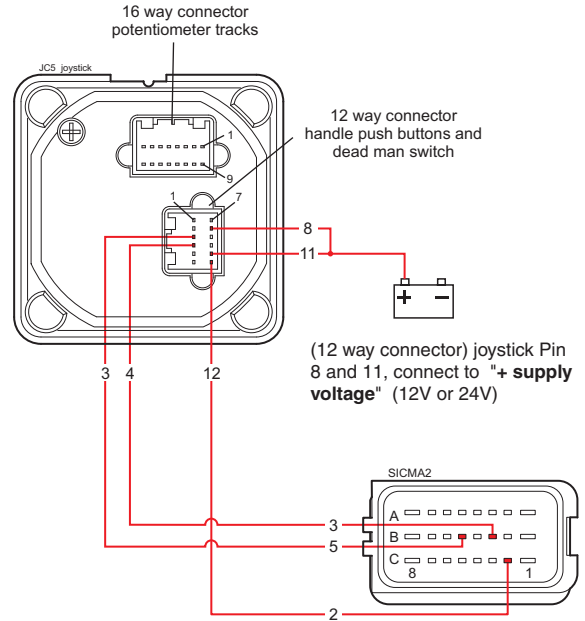

(12 way connector) joystick Pin 8 and 11, connect to "+ supply voltage" (12V or 24V)

PIN Joy.	Function	Connect to MAV
1	Button no. 4	C6
2	Button no. 3	C3
3	Button no. 2	B5
4	Button no. 1	B3
5	Button no. 5	C7
12	Dead man	C2

### Proportional single solenoid valve

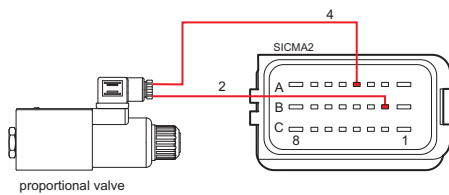

### Directional on/off valve

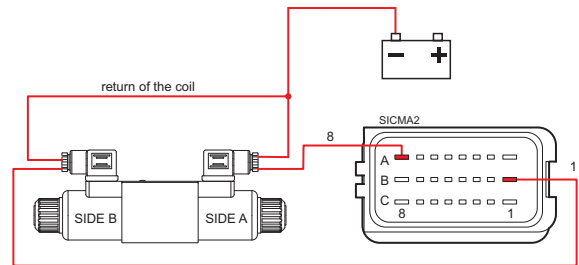

9

## MOUNTING EXAMPLE WITH DANA BREVINI PRODUCTS

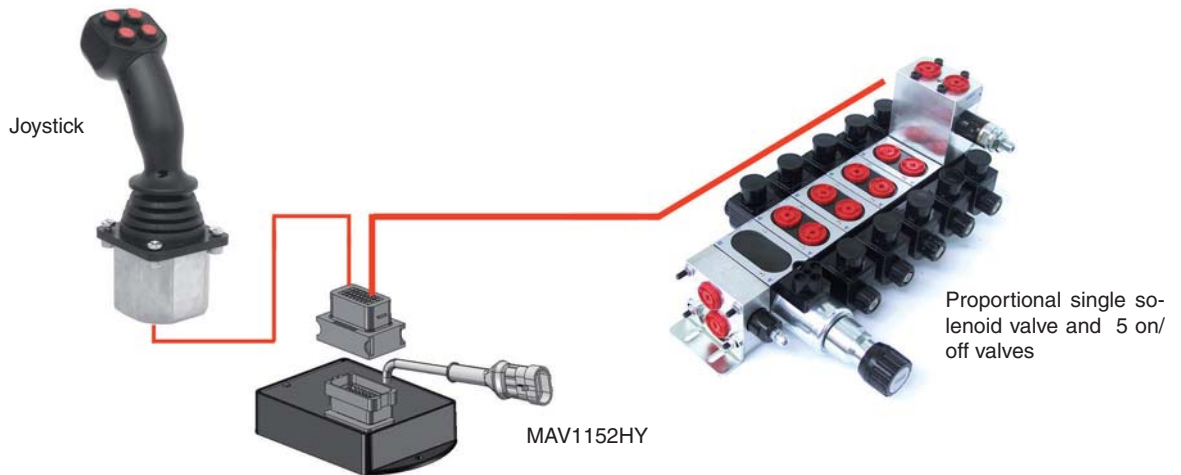

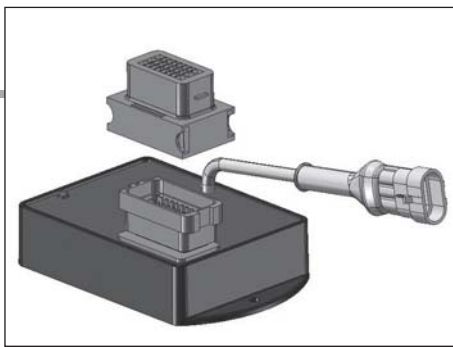

## MAV4211 ELECTRONIC MODULE FOR INTEGRATED CONTROL OF PROPORTIONAL VALVES

MAV4211: Electronic module for integrated control of proportional valves, bankable valves and proportional directional valves HPV.

The MAV4211 controller unit is used for the control of proportional solenoids and additional switching functions. The proportional solenoid outputs are pulse-width-modulated (PWM) and optimally adapted for electric proportional control. The switched outputs are designed for the direct switching of relays, lamps and switching solenoids. The MAV unit can managed up to 4 analog input signal and 8 PWM current output (4 PWM current output simultaneous, max load 9Amperes ).

The RS232 serial interface and BPE software tool enables the connection of PC for service functions, such as diagnostics, parameter setting or display of process variables.

European norms: EN 61000 - ElectroMagnetic Compatibility (EMC) - industrial environment

### MAV4211

LAYOUT	CAP. IX • 24
ELECTRICAL CONNECTINS	CAP. IX • 24
OVERALL DIMENSIONS	CAP. IX • 24
MOUNTING EXAMPLE	CAP. IX • 25

#### Optional (on request):

- on/off output for venting valve on CAT 3 safety

#### Adjustment parameters by RS232 link :

Frequency PWM  
 Offset current  
 Gain current  
 Ramp up time current  
 Ramp down time current  
 Analog input configuration (voltage 0.5 ÷ 4.5V, 1 ÷ 9V, current 4 ÷ 20mA).

### ORDERING CODE

Code	Description
7.365.1043	MAV4211 electronic module for integrated control of proportional valves
www.bpe.it	BPE Terminal software downloaded from www.bpe.it website

### SPECIFICATIONS:

Nominal voltage		12V and 24V
Operating supply voltage		9 ÷ 33Vdc
Current consumption	With load, max	9A
Protection Fuse	External	Rapid fuse 10A
Constant voltage source	For joystick supply	5V
Analog input selectable by serial link	Voltage	0.5 ÷ 4.5V
	Voltage	1 ÷ 9V
	Current	4 ÷ 20mA
Switch input	High or low active	Low < 1.5V; high > 6V
Proportional PWM output		0 ÷ 2A
PWM frequency range		70Hz ÷ 250Hz
On/off output (mosfet)		3A
Led indicator		Green/red/yellow
Interfaces		RS232 e CAN 2.0B
Number of analog input		4
Number of switch input		1
Number of PWM output		8
Number on/off output	For venting valve	1
Protezione da cortocircuito	Ingresso ed uscite	Yes
Protection against short circuit		Yes
Operating temperature		-40 ÷ 70°C
IP protection	With mounted mating connector	IP67
Mating connector	FCI - SICMA	24 pole

MAV product must be used with joysticks JCFD1GG1 output signal 10-90% or similar.



Plug-in connector 24 poles FCI - SICMA (to be ordered separately)

Code	Description
7.003.054	Connector
7.180.403	Connector with 1 mt. cable length

## LAYOUT

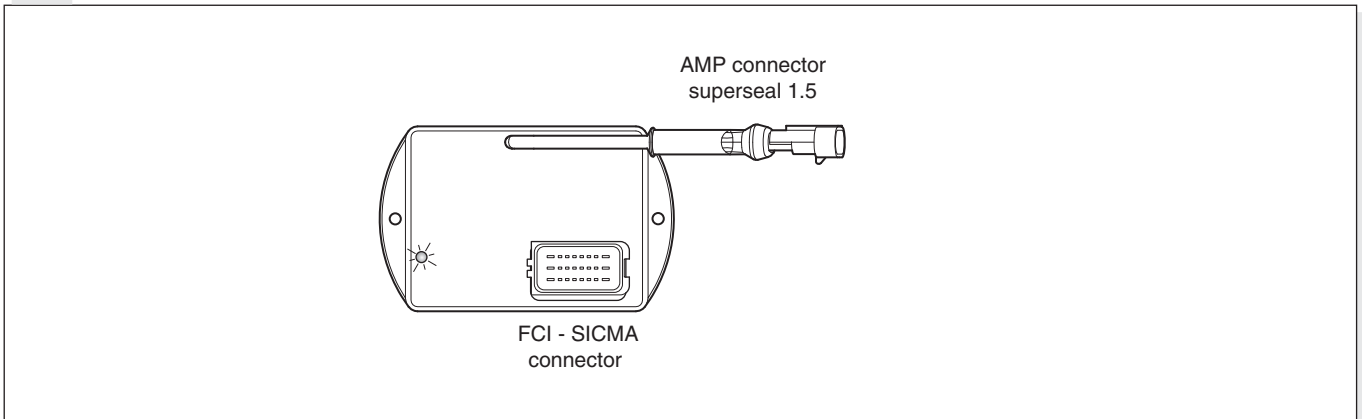

## ELECTRICAL CONNECTINS

Contacts description MAV4211: Mating Connector FCI - SICMA

PIN	8	7	6	5	4	3	2	1
<b>A</b>	On/off output	Return PWM 4 A AND B	Return PWM 1 A AND B	PWM out 2B B	CAN_H	PWM out 4B	PWM out 4A	+ Supply
<b>B</b>	PWM out 1B	Return PWM 3 A and B	Return PWM 2 A and B	Switch input 1	Analog input 1	Analog input 3	PWM out 3B	PWM out 3A
<b>C</b>	PWM out 2A	5V joystick supply	PWM out 1A	Not used	Analog input 2	Analog input 4	CAN_L	- Supply

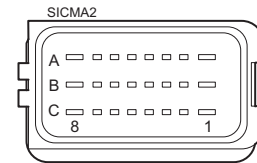

Serial Link RS232 connector : AMP superseal 1.5

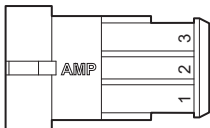

PIN 1	PIN 2	PIN 3
GND	RX	TX

Connection example:

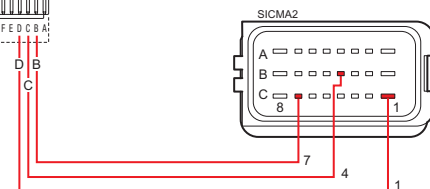
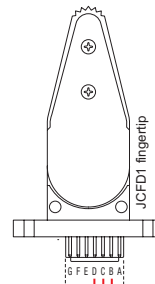
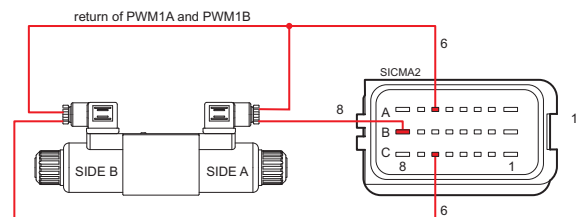

9

## OVERALL DIMENSIONS

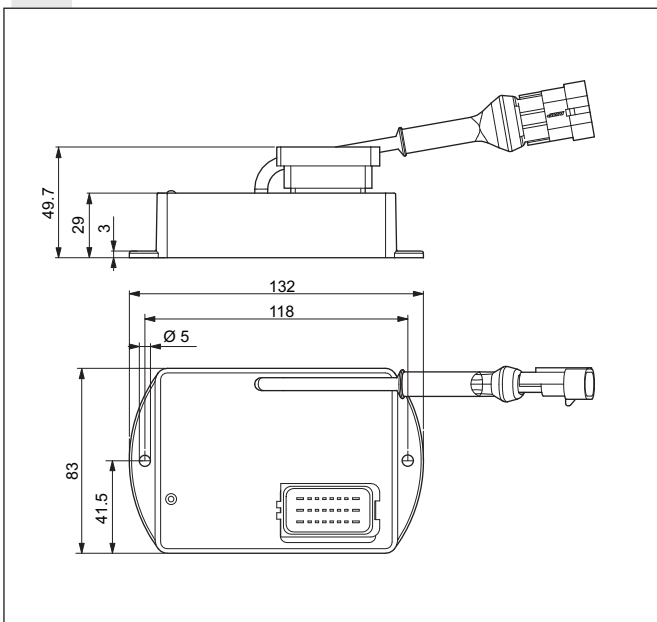

## MOUNTING EXAMPLE WITH DANA BREVINI PRODUCTS

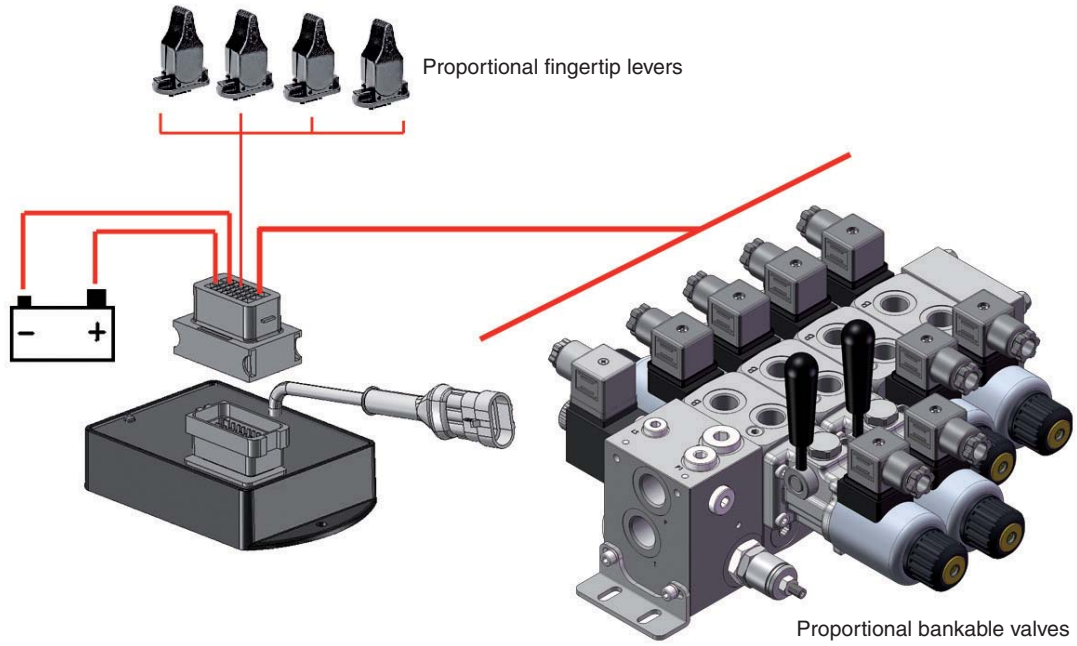

**NOTE: MAV product must be used with joysticks JCFD1GG1 output signal 10-90% or similar.**

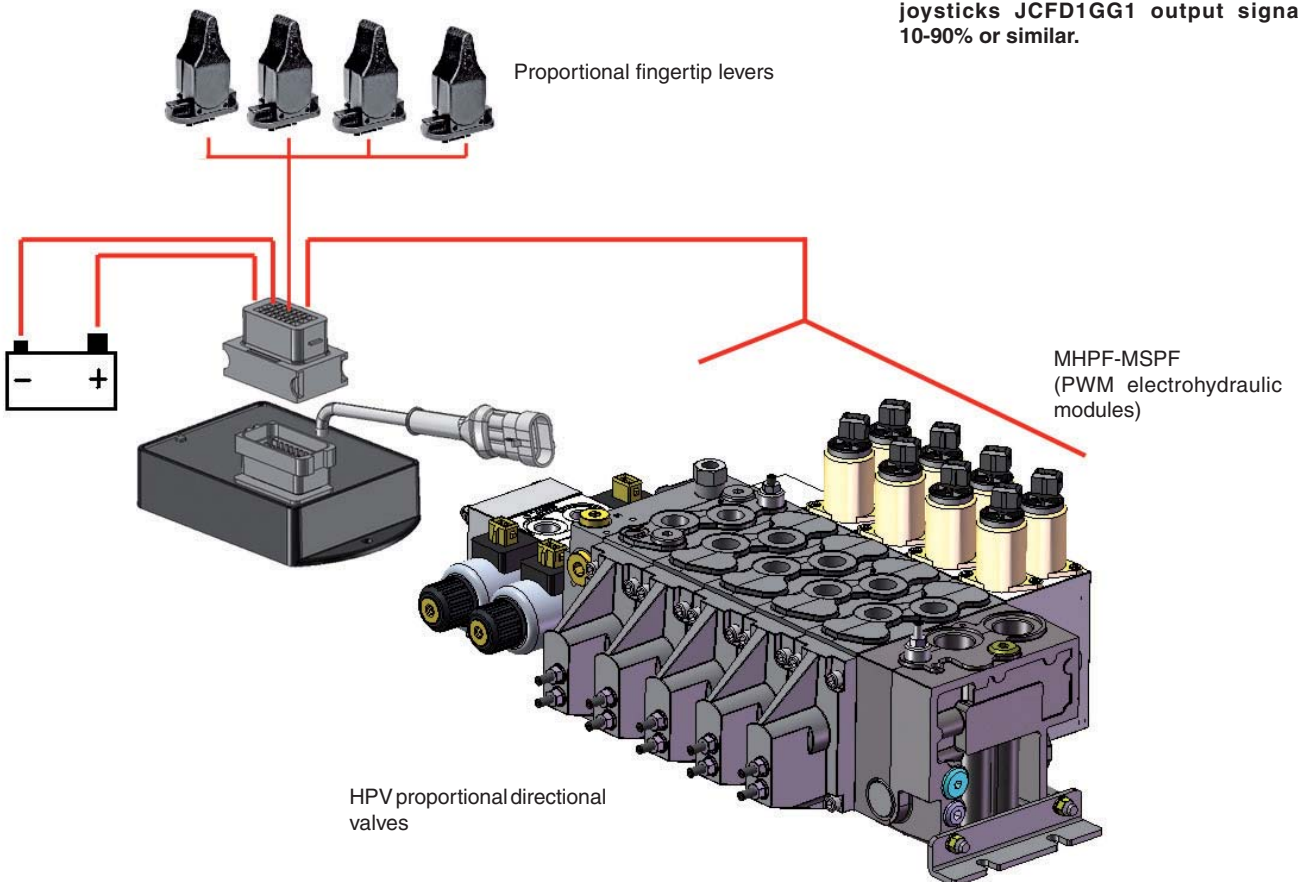

## JC3D... HEAVY DUTY SINGLE JOYSTICK BASE



JC3D...

This is a rugged joystick with single axis Y potentiometer and ergonomic handle. The joystick has a spring return lever for center position. The panel material for this joystick and thickness must be strong and rigid. The panel thickness should have a dimension of minimum 3.5mm and maximum 6mm. The joystick has two directional micro-switches per Y axis. The handle has 3 pushbuttons and it is possible to have the operator present switch too.

The IP protection of joystick is referred to above mounting panel and it can be max. IP65. N.B. below mounting panel the rating is IP40.

### APPLICATIONS

The joystick has been designed for aerial platform, agricultural and forestry machinery. The use of this product with the electronic control unit for non contemporary movements gives the maximum advantage for hydraulic solutions controlled with a proportional valve.

### Electrical features

Potentiometer resistance	1.4 ÷ 2.2 K $\Omega$
Max. supply voltage	VDD = 32V DC
Max. supply voltage Y pot	0 – 100% VDD
Max. output current	5 mA

### Directional switches

Maximum supply voltage	VCC = 32V DC
Max. output current	200 mA
	Resistive load

### Mechanical features

Mechanical angle	$\pm 20^\circ$
Maximum operating load	390 N
(Measured 130 mm above the mounting surface)	
Mechanical Life (Y axis)	7.500.000 cycles
Weight (handle include)	0,900 Kg

Ambient operating temperature	-40°C ÷ +80°C
Protection according to DIN	IP65
Shocks	Level 20G Type ½ sine 6ms
	Number of shocks 1350 per axis

### ORDERING CODE

<b>JC</b>	Heavy duty single Joystick
<b>3</b>	Handle (3 switches)
<b>D</b>	Directional switches
<b>1</b>	Functional operation single axis (Y)
<b>A</b>	With operator present trigger switch
<b>**</b>	<b>00</b> = No variants <b>GD</b> = With silicon rubber protection on the switches handle
<b>1</b>	Serial number

• **CE** Registered mark for industrial environment with reference to the compatibility. European norms:

- IEC 61000-4-3 "Electromagnetic immunity"
- EN6550022 "Electromagnetic emissions"

• Product in accordance with **RoHS** 2011/65/UE Europe Directive.

9

Connectors and electrical contacts included in the furniture.

### POTENTIOMETER OUTPUT AXIS Y

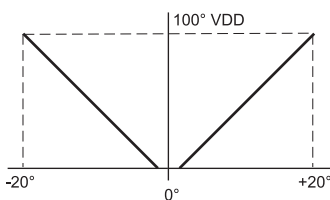

In order to obtain the Y axis output signal from the joystick as indicated in the diagram over it is necessary to connect the pin 9 and 11 of the AMP 16 way connector at +VDD, and to connect the pin 12 of the AMP 16 way connector at 0V.

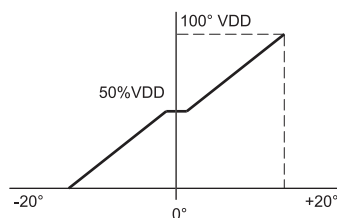

In order to obtain the Y axis output signal from the joystick as indicated in the diagram over it is necessary to connect the pin 9 of the AMP 16 way connector at 0V, and to connect the pin 11 of the AMP 16 way connector at +VDD.

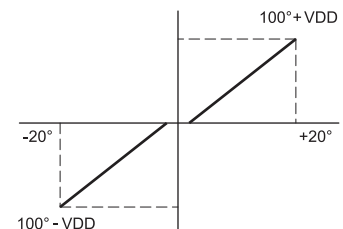

In order to obtain the Y axis output signal from the joystick as indicated in the diagram over it is necessary to connect the pin 9 of the AMP 16 way connector at -VDD, and to connect the pin 11 of the AMP 16 way connector at +VDD.



# JC3D... . HEAVY DUTY SINGLE JOYSTICK BASE

## CONNECTOR CONFIGURATION AND PIN ALLOCATION DETAIL

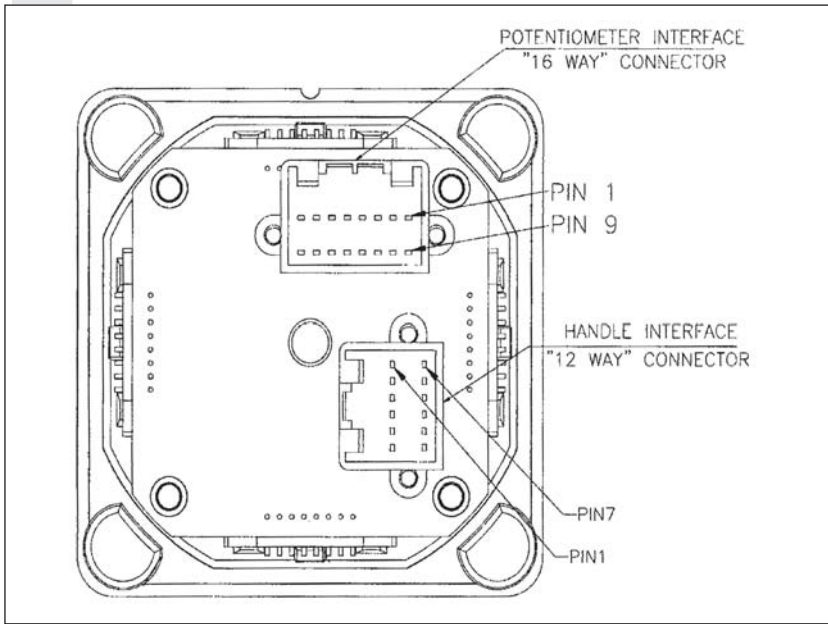

### FROM THE 16 WAY PRIMARY POTENTIOMETER CONNECTIONS SINGLE POTENTIOMETER PER Y AXIS

AMP	Pin allocation description
1	Y Switch track forward
9	Y Pot track back
10	Y Pot track signal
11	Y Pot track forward
12	Y Pot track centre tap
13	Y Switch track common
14	Y Switch track back
16	Y Switch track centre on

## 12 WAY HANDLE CONNECTIONS

AMP	Pin allocation description
2	Switch 3 - contact N/O
3	Switch 2 - contact N/O
4	Switch 1 - contact N/O
8	Operator present trigger switch
11	Switch track common
12	Operator present trigger switch

## OVERALL DIMENSIONS

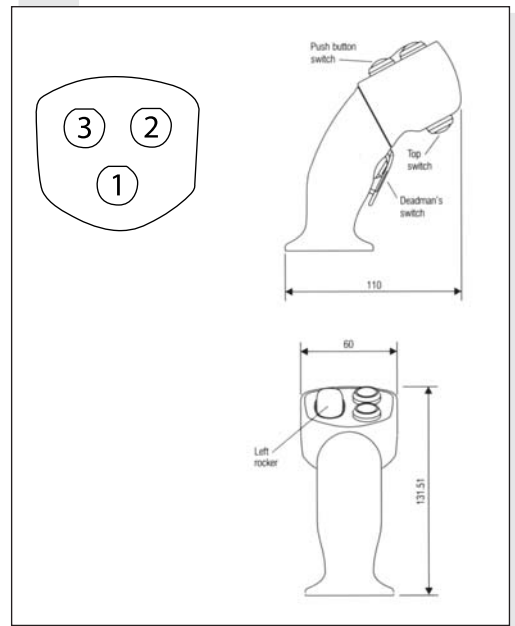

## SPARE PARTS AMP 040 SERIES MULTILOCK

Receptacle contacts  
**P.No. 175062-1\*** Loose piece

Plug housing 12 position  
**P.No. 174045-2\***

Plug housing 16 position double row  
**P.No. 174046-2\***

\* AMP code

**Spare parts kit, connectors and electrical contacts: V89900000**

## HANDLE ADAPTER PLATE

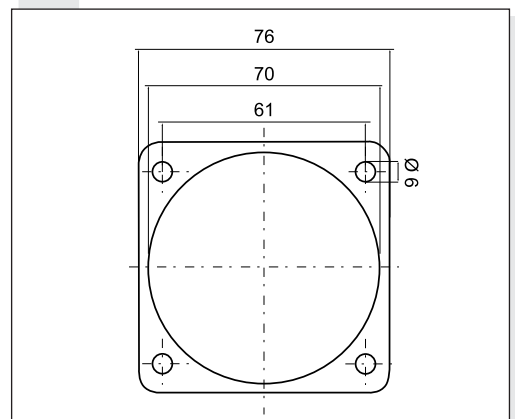

## ANALOGUE JOYSTICK CONTROLLERS

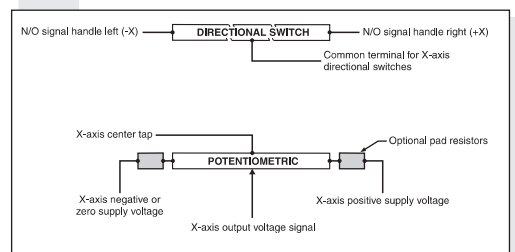

## JC5D... HEAVY DUTY SINGLE JOYSTICK BASE



JC5D...

This is a rugged joystick with potentiometer and ergonomic handle. The joystick has a spring return lever for center position. Single axis Y or dual axes XY are available. The panel material for this joystick and thickness must be strong and rigid. The panel thickness should have a dimension of minimum 3.5mm and maximum 6mm. The joystick has two directional micro-switches per axis. The handle has 5 pushbuttons and it is possible to have the operator present switch too.

The IP protection of joystick is referred to above mounting panel and it can be max. IP65. N.B. below mounting panel the rating is IP40.

### APPLICATIONS

The joystick has been designed for aerial platform, agricultural and forestry machinery. The use of this product with the electronic control unit for non contemporary movements gives the maximum advantage for hydraulic solutions controlled with a proportional valve.

### ORDERING CODE

<b>JC</b>	Heavy duty single Joystick
<b>5</b>	Handle (5 switches)
<b>D</b>	Directional switches
<b>*</b>	Functional operation <b>1</b> = single axis (Y) <b>2</b> = dual axis (XY)
<b>*</b>	<b>A</b> = With operator present trigger switch <b>B</b> = Without operator present trigger switch
<b>00</b>	No variants
<b>1</b>	Serial number

Electrical features	
Potentiometer resistance	1.4 ÷ 2.2 KΩ
Max. supply voltage	VDD = 32V DC
Max. supply voltage X and Y pot	0 – 100% VDD
Max. output current	5 mA

Directional switches	
Maximum supply voltage	VCC = 32V DC
Max. output current	200 mA
	Resistive load

Mechanical features	
Mechanical angle	± 20°
Maximum operating load	390 N
(Measured 130 mm above the mounting surface)	
Mechanical Life (X and Y axis)	7.500.000 cycles
Weight (handle include)	0,900 Kg

Ambient operating temperature	-40°C ÷ +80°C
Protection according to DIN	IP65
Shocks	Level 20G Type ½ sine 6ms
	Number of shocks 1350 each axis

• **CE** Registered mark for industrial environment with reference to the compatibility. European norms:

- IEC 61000-4-3 "Electromagnetic immunity"
- EN6550022 "Electromagnetic emissions"

• Product in accordance with **RoHS** 2011/65/UE Europe Directive.

Connectors and electrical contacts included in the furniture.

9

### POTENTIOMETER OUTPUT AXIS X,Y

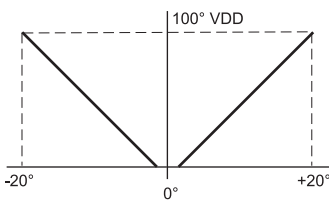

In order to obtain the output signal from the joystick as indicated in the diagram over it is necessary:

- for the X axis output signal, connect the pin 3 and 5 of the AMP 16 way connector at +VDD, and connect the pin 6 of the AMP 16 way connector at 0V.

- for the Y axis output signal, connect the pin 9 and 11 of the AMP 16 way connector at +VDD, and connect the pin 12 of the AMP 16 way connector at 0V.

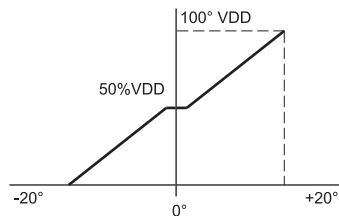

In order to obtain the output signal from the joystick as indicated in the diagram over it is necessary:

- for the X axis output signal, connect the pin 3 of the AMP 16 way connector at 0V, and connect the pin 5 of the AMP 16 way connector at +VDD.

- for the Y axis output signal, connect the pin 9 of the AMP 16 way connector at 0V, and connect the pin 11 of the AMP 16 way connector at +VDD.

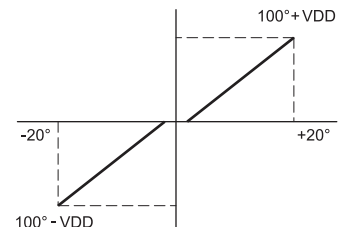

In order to obtain the output signal from the joystick as indicated in the diagram over it is necessary:

- for the X axis output signal, connect the pin 3 of the AMP 16 way connector at -VDD, and connect the pin 5 of the AMP 16 way connector at +VDD.

- for the Y axis output signal, connect the pin 9 of the AMP 16 way connector at -VDD, and connect the pin 11 of the AMP 16 way connector at +VDD.

# JC5D... . HEAVY DUTY SINGLE JOYSTICK BASE

## CONNECTOR CONFIGURATION AND PIN ALLOCATION DETAIL

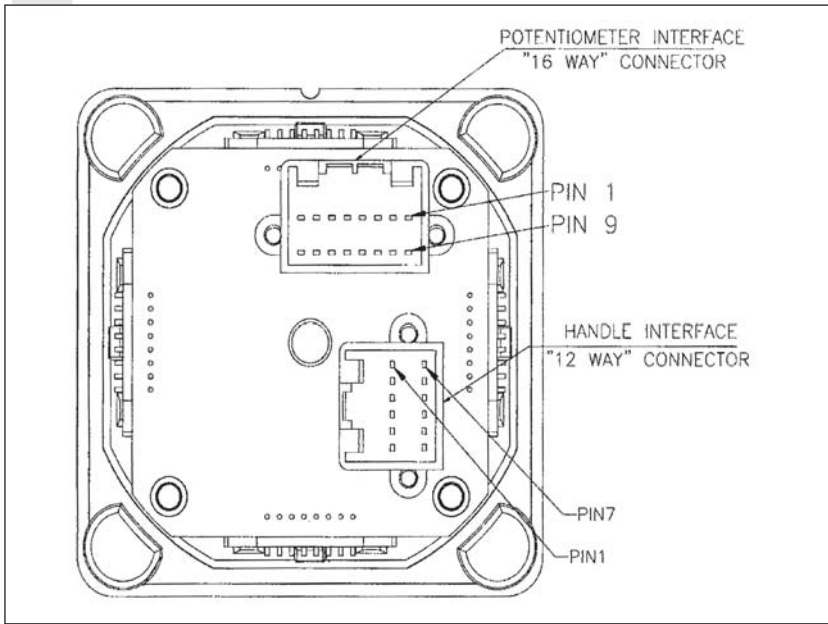

### 16 WAY PRIMARY POTENTIOMETER CONNECTIONS

AMP	Pin allocation description
	<b>Single potentiometer per axis</b>
1	Y Switch track forward
2	X Switch track centre on
3	X Pot track left
4	X Pot track signal
5	X Pot track right
6	X Pot track centre tap
7	X Switch track common
8	X Switch track left
9	Y Pot track back
10	Y Pot track signal
11	Y Pot track forward
12	Y Pot track centre tap
13	Y Switch track common
14	Y Switch track back
15	X Switch track right
16	Y Switch track centre on

### SPARE PARTS AMP 040 SERIES MULTILOCK

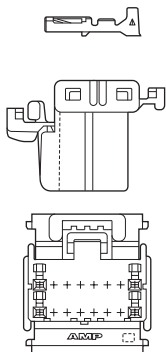

Receptacle contacts  
P.No. 175062-1\* Loose piece

Plug housing 12 position  
P.No. 174045-2\*

Plug housing 16 position double row  
P.No. 174046-2\*

\* AMP code

Spare parts kit, connectors and electrical contacts: V89900000

### 12 WAY HANDLE CONNECTIONS

AMP	Pin allocation description
1	Switch 4 - contact N/O
2	Switch 3 - contact N/O
3	Switch 2 - contact N/O
4	Switch 1 - contact N/O
5	Switch 5 - contact N/O
8	Operator present trigger switch
11	Switch track common
12	Operator present trigger switch

### OVERALL DIMENSIONS

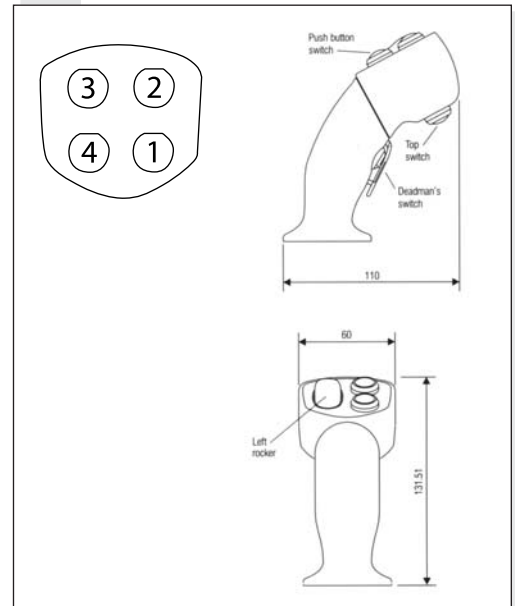

### HANDLE ADAPTER PLATE

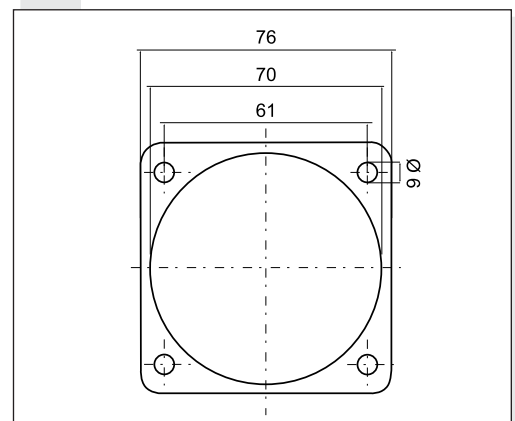

### ANALOGUE JOYSTICK CONTROLLERS

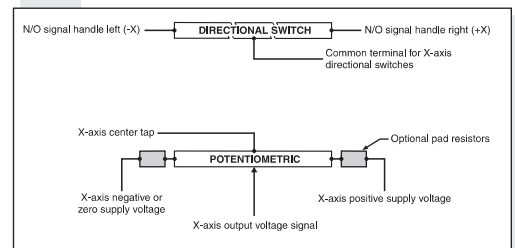

## JCFD... SINGLE-AXIS FINGERTIP JOYSTICK



JCFD...

Developed for applications where ergonomics and system integrity are paramount, the JCFD is a compact, low profile joystick that provides precise fingertip control. Designed for use with an electronic controller, the plastic track generates analogue and switched reference signals, proportional to the distance and direction over which the handle is moved. The analogue output is configured to provide signals for fault detection circuits within the controller. A center tap on the analogue track provides an accurate voltage reference for the center position or a zero point for a bipolar supply voltage.

### Electrical features

Potentiometer resistance	5 K $\Omega$
Max. supply voltage	VDD = 32V DC
Output signal Y pot	0 – 100% VDD
Output signal Y pot GG variant	10 - 90% VDD
Max. output current	2mA

### Directional switches

Maximum supply voltage	VCC = 32V DC
Max. output current	2mA
	Resistive load

### Mechanical features

Mechanical angle	$\pm 30^\circ$
Maximum operating load	50 N
(Measured 130 mm above the mounting surface)	
Mechanical Life	5.000.000 cycles
Weight	0,045 Kg

Ambient operating temperature	-25°C ÷ +70°C
Protection according to DIN	IP66

### ORDERING CODE

<b>JC</b>	Joystick
<b>F</b>	Fingertip
<b>D</b>	Directional switches
<b>1</b>	Singolo asse
<b>**</b>	<b>00</b> = No variants <b>GG</b> = 10-90% output signal
<b>1</b>	Serial number

- **CE** Registered mark for industrial environment with reference to the compatibility. European norms:
  - IEC 61000-4-3 "Electromagnetic immunity"
  - EN6550022 "Electromagnetic emissions"
- Product in accordance with **RoHS 2011/65/UE** Europe Directive.

9

Connectors and electrical contacts included in the furniture.

### OUTPUT VOLTAGE SIGNAL

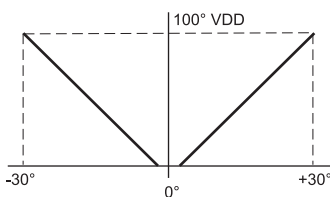

In order to obtain the output signal from the joystick as indicated in the diagram it is necessary: connect the Pin B and Pin D of the connector at +VDD, and connect the Pin A at 0V.

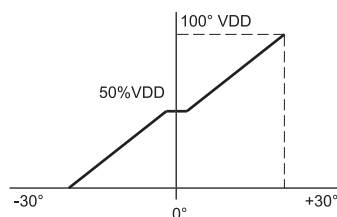

In order to obtain the output signal from the joystick as indicated in the diagram it is necessary: connect the Pin B of the connector at +VDD, and connect the Pin D at 0V.

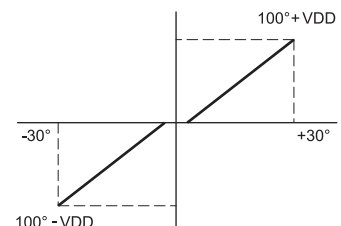

In order to obtain the output signal from the joystick as indicated in the diagram it is necessary: connect the Pin B of the connector at +VDD, and connect the Pin D at -VDD.

# JCFD... SINGLE-AXIS FINGERTIP JOYSTICK

## HANDLE ADAPTER PLATE

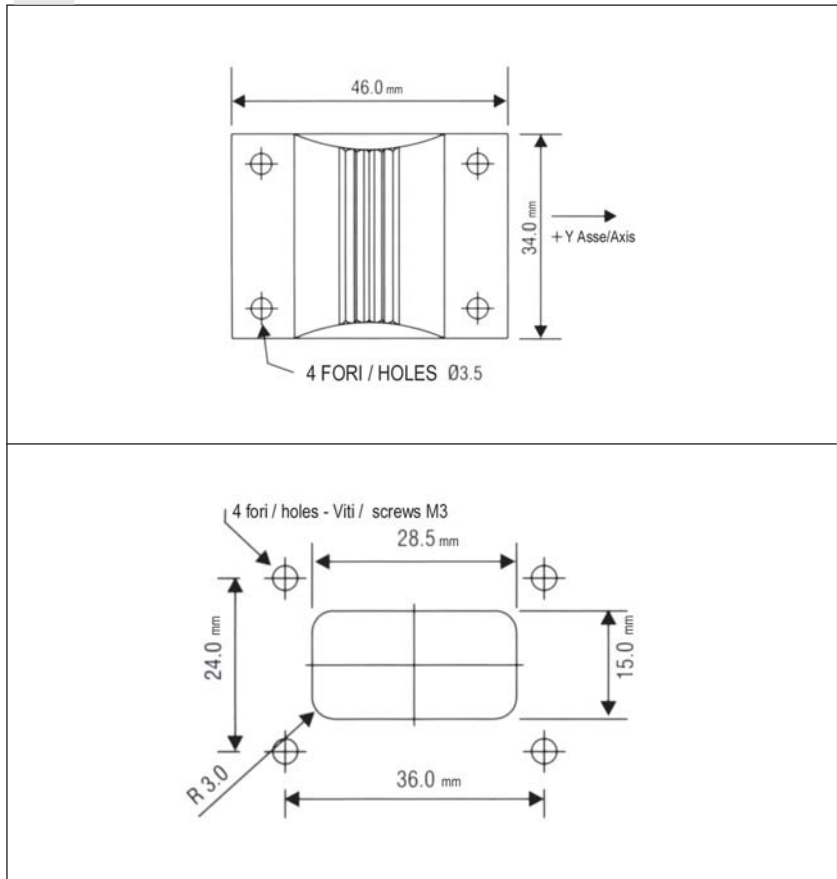

## OVERALL DIMENSIONS

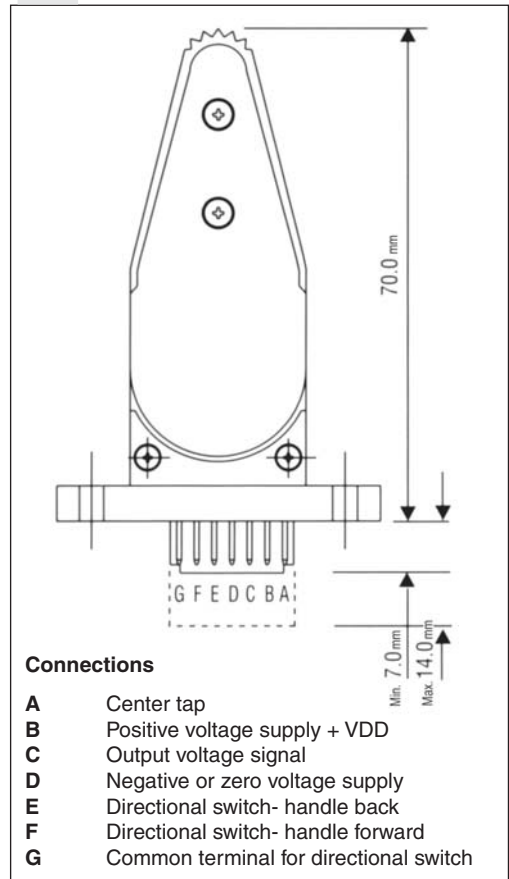

### Connections

- A** Center tap
- B** Positive voltage supply + VDD
- C** Output voltage signal
- D** Negative or zero voltage supply
- E** Directional switch- handle back
- F** Directional switch- handle forward
- G** Common terminal for directional switch

## SPARE PARTS

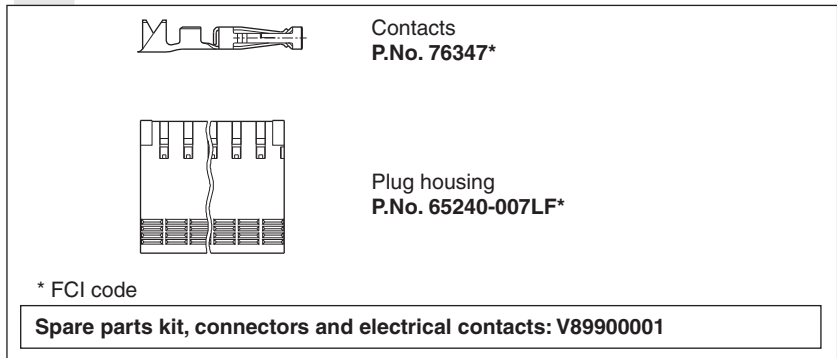

## ANALOGUE JOYSTICK CONTROLLERS

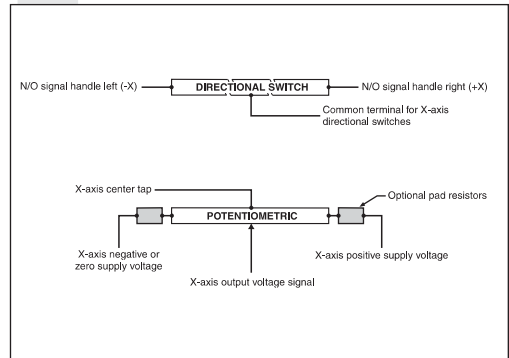



## ABBREVIATIONS

<b>AP</b>	HIGH PRESSURE CONNECTION
<b>AS</b>	PHASE LAG (DEGREES)
<b>BP</b>	LOW PRESSURE CONNECTION
<b>C</b>	STROKE (MM)
<b>CH</b>	ACROSS FLATS
<b>Ch</b>	INTERNAL ACROSS FLATS
<b>DA</b>	AMPLITUDE DECAY (dB)
<b>DP</b>	DIFFERENTIAL PRESSURE (BAR)
<b>F</b>	FORCE (N)
<b>I%</b>	INPUT CURRENT (A)
<b>M</b>	MANOMETER CONNECTION
<b>NG</b>	KNOB TURNS
<b>OR</b>	SEAL RING
<b>P</b>	LOAD PRESSURE (BAR)
<b>PARBAK</b>	PARBAK RING
<b>PL</b>	PARALLEL CONNECTION
<b>Pr</b>	REDUCED PRESSURE (BAR)
<b>Q</b>	FLOW (L/MIN)
<b>QP</b>	PUMP FLOW (L/MIN)
<b>SE</b>	ELASTIC PIN
<b>SF</b>	BALL
<b>SR</b>	SERIES CONNECTION
<b>X</b>	PILOTING
<b>Y</b>	DRAINAGE

## LOW / HIGH PRESSURE UNITS



BA60...	CAP. X • 2
BA130...	CAP. X • 5
BSC569...	CAP. X • 7

## SPECIAL SUBPLATE MOUNTINGS WITH AUTOMATIC EXCLUSION REGENERATING CIRCUIT



BS5RGA...	CAP. X • 8
BS5RGI...	CAP. X • 8
AD5IP2T1	CAP. I • 47

# BA60...

## LOW / HIGH PRESSURE UNITS



### BA60...

BA06/10...	CAP. X • 3
CMP10...	CAP. VII • 30
BC0630/32... / BC0640...	CAP. VII • 15
BC530/32...	CAP. VII • 26
BC540...	CAP. VII • 25
CETOP 3/NG06	CAP. I • 5
CETOP 5/NG10	CAP. I • 33

The low/high pressure groups are usually employed in hydraulic systems fed by dual pumps that form a single pressure circuit.

The main feature of this system consists in being able to set a pressure value in correspondence of which one of the two pumping sections is changed over to drain.

Max. flow	60 l/min
Max. operating pressure	320 bar
Fluid viscosity	10 ÷ 500 mm <sup>2</sup> /s
Fluid temperature	-25°C ÷ 75°C
Ambient temperature	-25°C ÷ 60°C
Max. contamination level	class 10 in accordance with NAS 1638 with filter $\beta_{25} \geq 75$
Weight	see "overall dimensions"

These groups are fitted with an adjustable maximum pressure valve to protect the hydraulic system.

3 pressure adjustment ranges are available for the exclusion valve, which is fitted with cast iron or steel seat, while the maximum pressure valve type CMP10 is available with 3 adjustment ranges.

**Minimum permissible setting pressure depending on the spring: see cartridge valve type CMP10.**

The series connection modular small block (BC0632/BC532) or the parallel connection type (BC0630/BC530) with blanking plate (BC0640/BC540) and the solenoid valve should be ordered separately.

For the subplate mounting ordering code see "Subplates" chapter; whilst for the valve ordering code see "Directional control valves" chapter.

The CETOP3/NG06 connector blocks have 2 rods, the CETOP5/NG10 have 3 rods.

BC1006 = reduction plate to be used only for assembly of modular blocks CETOP3/NG06.

### PRESSURE DROPS

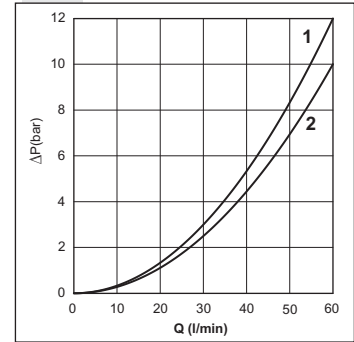

Curve	1 = BP → P 2 = BP → T
-------	--------------------------

### ORDERING CODE

<b>BA</b>	Low/high pressure base
<b>60</b>	Capacity l/min
<b>U*</b>	TDouble pump exclusion valve setting 2 = max. 30 bar 3 = max. 75 bar 4 = max. 100 bar
<b>C</b>	Type of adjustment: grub screw
<b>*</b>	Max. pressure valve setting 1 = max. 50 bar 2 = max. 150 bar 3 = max. 320 bar
<b>**</b>	<b>00</b> = No variant <b>V1</b> = Viton
<b>1</b>	Serial No.

### OVERALL DIMENSIONS AND HYDRAULIC SYMBOL

Fixing screws M6x100 UNI 5931  
Weight 6.6 Kg

**In series connection the last block at the top, must be connected in parallel (BC0630) only for mounting CETOP3/NG06 modular valves.**

### MODULE ORDERING CODE

<b>BA</b>	Subplate mounting
<b>**</b>	<b>06</b> = CETOP 3/NG06 <b>10</b> = CETOP 5/NG10
<b>**</b>	Type of module: <b>62</b> = side CETOP interface <b>66</b> = top CETOP interface <b>68</b> = with upper threaded connectors (only for CETOP 5)
<b>**</b>	<b>00</b> = No variant <b>V1</b> = Viton
<b>1</b>	Serial No.

10



# BA60... Low / HIGH PRESSURE UNITS

## OVERALL DIMENSIONS AND HYDRAULIC SYMBOLS

### SIDE MOUNTING FOR SINGLE SOLENOID VALVE CETOP3/NG06 (CONNECTOR BLOCK BA.06.62)

Fixing screws M10x55 UNI 5931 - Weight 2 Kg

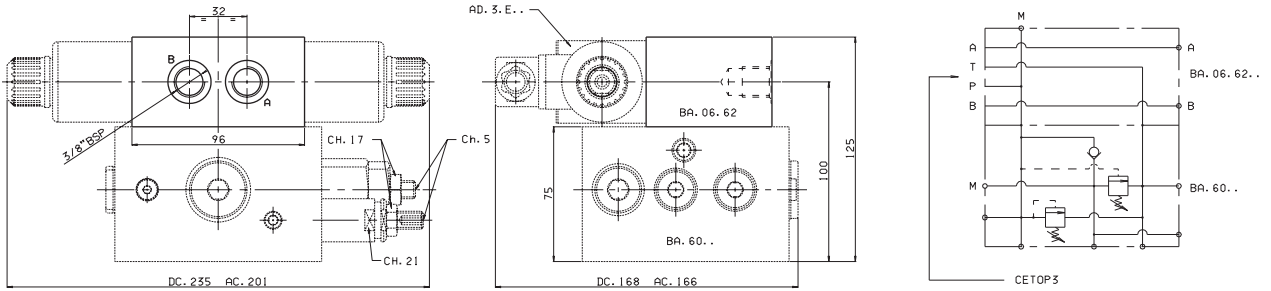

### SIDE MOUNTING FOR SINGLE SOLENOID VALVE CETOP5/NG10 (CONNECTOR BLOCK BA.10.62)

Fixing screws M10x80 UNI 5931 - Weight 3 Kg

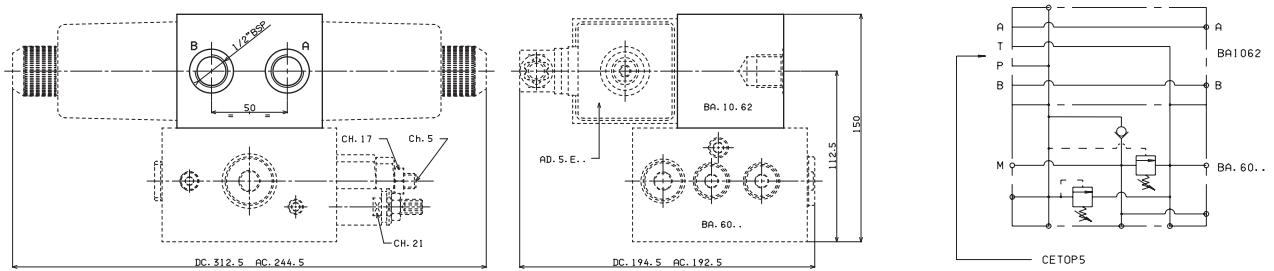

### TOP MOUNTING FOR SINGLE SOLENOID VALVE CETOP3/NG06 (CONNECTOR BLOCK BA.06.66)

Fixing screws M10x50 UNI 5931 - Weight 2.5 Kg

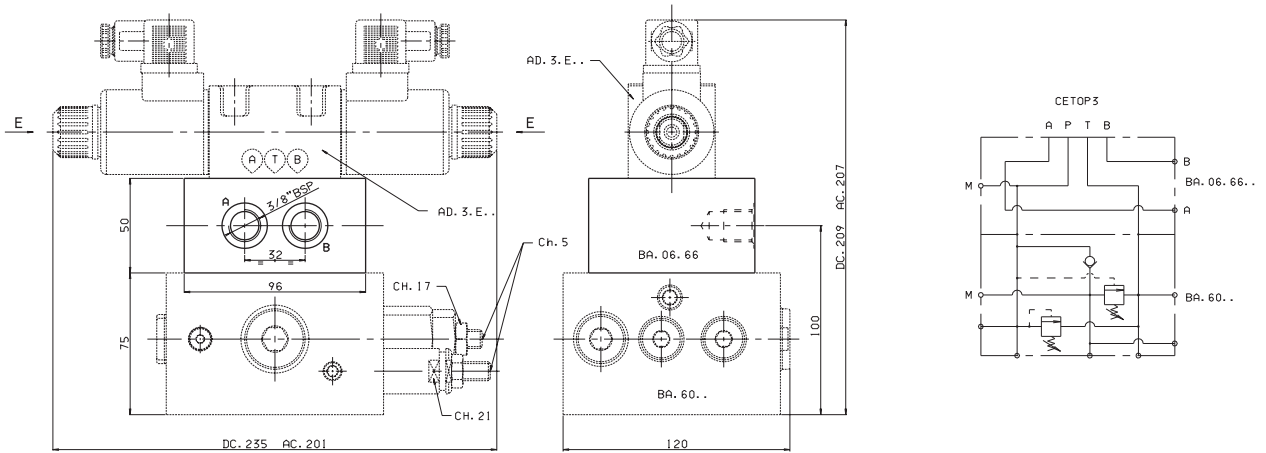

### TOP MOUNTING FOR SINGLE SOLENOID VALVE CETOP5/NG10 (CONNECTOR BLOCK BA.10.66)

Fixing screws M10x50 UNI 5931 - Weight 2.4 Kg

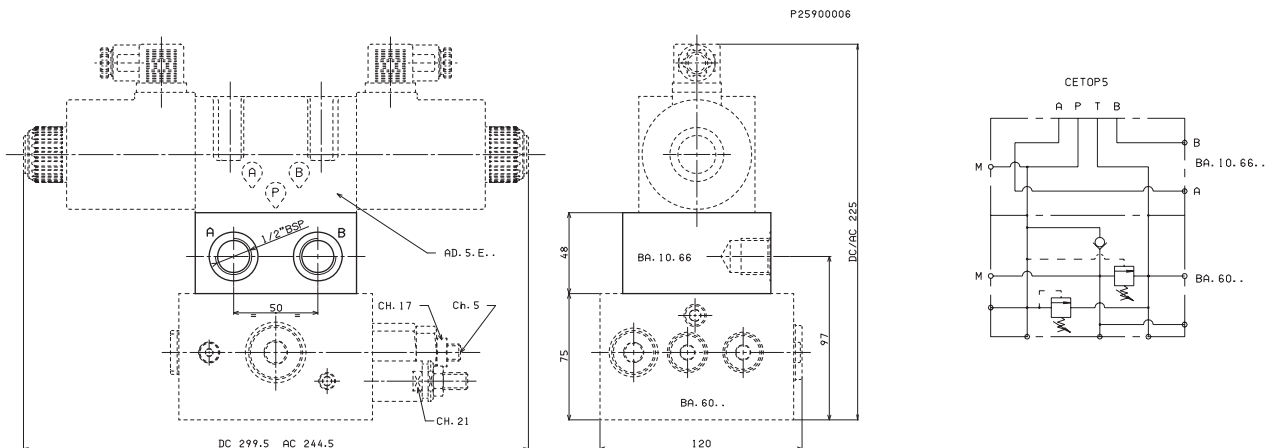

10

# BA60... Low / HIGH PRESSURE UNITS

## OVERALL DIMENSIONS AND HYDRAULIC SYMBOLS

### MOUNTING WITH THREADED CONNECTORS (CONNECTOR BLOCK BA1068)

Fixing screws M10x45 UNI 5931- Weight 1.6 Kg

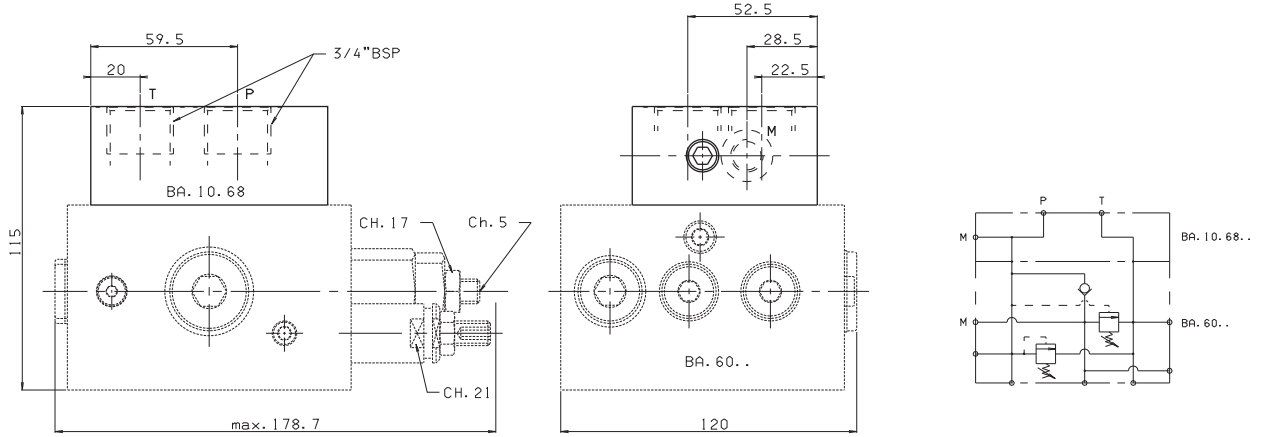

### MULTIPLE MOUNTING WITH MODULAR COMPONENT CONNECTOR BLOCKS CONNECTED IN SERIES OR PARALLEL CETOP3/NG06

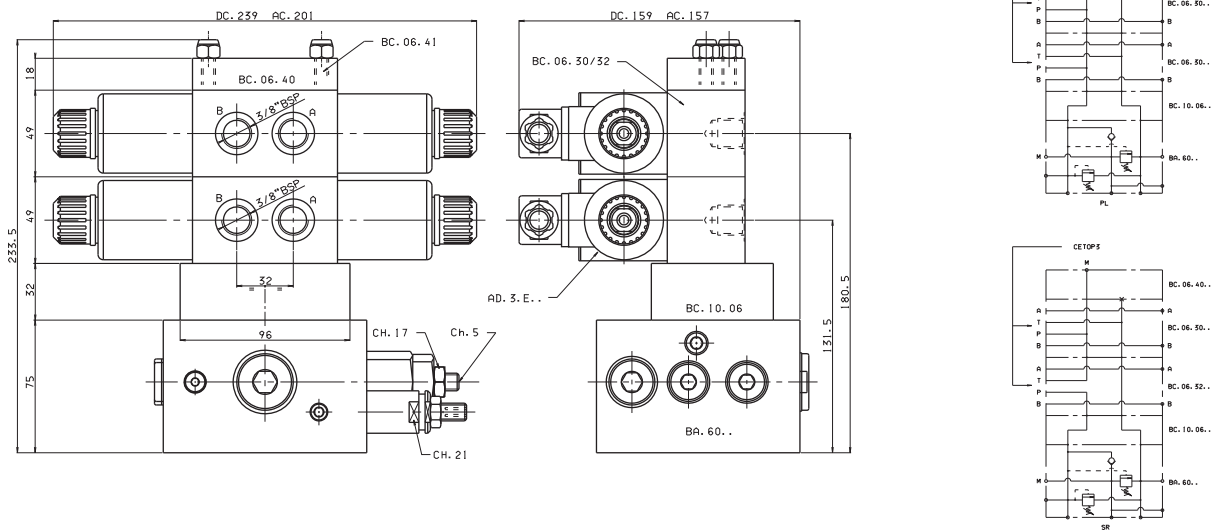

### MULTIPLE MOUNTING WITH MODULAR COMPONENT CONNECTOR BLOCKS CONNECTED IN SERIES OR PARALLEL CETOP5/NG10

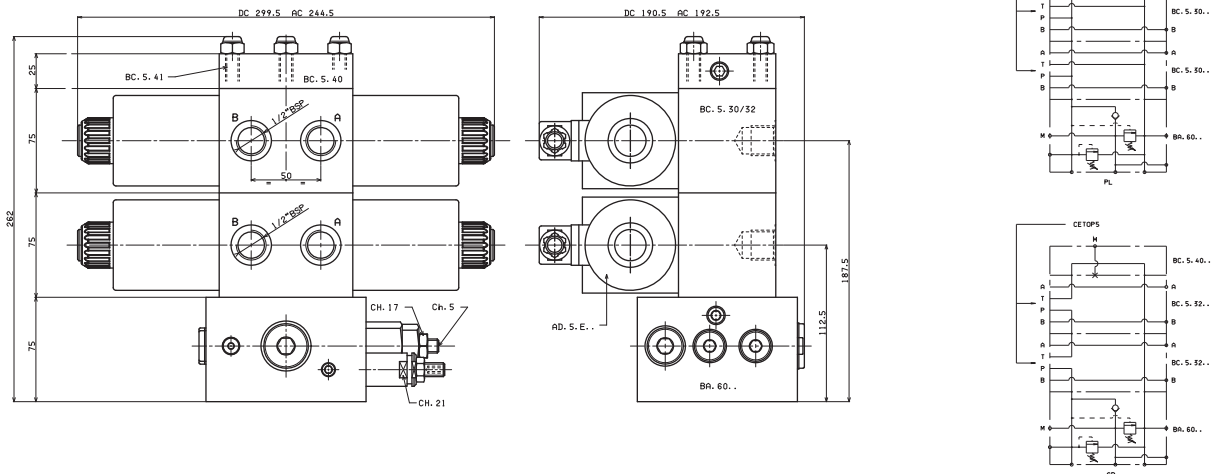

10

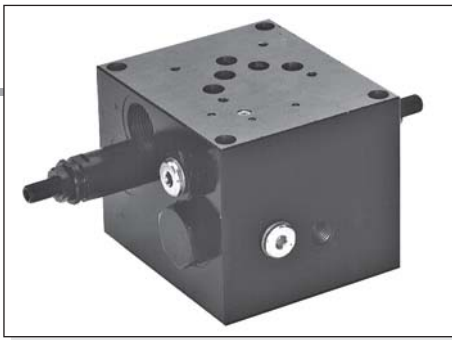

## BA130... Low / HIGH PRESSURE UNITS

The low/high pressure groups are usually employed in hydraulic systems fed by dual pumps that form a single pressure circuit. The main feature of this system consists in being able to set a pressure value in correspondence of which one of the two pumping sections is changed over to drain.

These groups are fitted with an adjustable maximum pressure valve to protect the hydraulic system.

2 pressure adjustment ranges are available for the exclusion valve, which is fitted with a steel seat, while the maximum pressure valve type CMP10 is available with 3 adjustment ranges.

**Minimum permissible setting pressure depending on the spring: see cartridge valve type CMP10.**

The series connection modular small block (BC532) or the parallel connection type (BC530) with blanking plate (BC540) and the solenoid valve should be ordered separately.

For the subplate mounting ordering code see "Subplates" chapter; whilst for the valve ordering code see "Directional control valves" chapter.

The CETOP5/NG10 connector blocks have 3 rods.

Max. flow	130 l/min
Max. operating pressure	320 bar
Fluid viscosity	10 ÷ 500 mm <sup>2</sup> /s
Fluid temperature	-25°C ÷ 75°C
Ambient temperature	-25°C ÷ 60°C
Max. contamination level	class 10 in accordance with NAS 1638 with filter $\beta_{25} \geq 75$
Weight	8 Kg

### PRESSURE DROPS

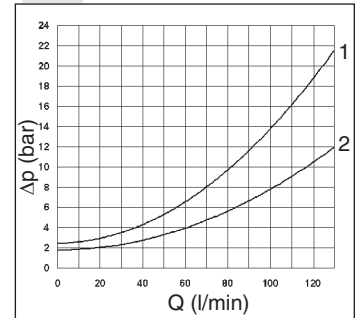

Curve	1 = P1 → T
	2 = P1 → P

### BA130...

BA10...	CAP. X • 3
CMP10...	CAP. VII • 30
BSC569...	CAP. X • 7
BC530/32...	CAP. VII • 26
BC540...	CAP. VII • 25
CETOP 5/NG10	CAP. I • 33
ADP5E...	CAP. I • 41

### ORDERING CODE

<b>BA</b>	Low/high pressure base
<b>130</b>	Capacity l/min
<b>U*</b>	Double pump exclusion valve setting 2 = 20 ÷ 90 bar 3 = 50 ÷ 190 bar
<b>C</b>	Type of adjustment: grub screw
<b>*</b>	Max. pressure valve setting 1 = max. 50 bar 2 = max. 150 bar 3 = max. 320 bar
<b>00</b>	No variant
<b>1</b>	Serial No.

### MODULE ORDERING CODE

<b>BA</b>	Subplate mounting
<b>10</b>	CETOP 5/NG10
<b>**</b>	Type of module: 62 = side CETOP interface 68 = with upper threaded connectors
<b>00</b>	No variant
<b>1</b>	Serial No.

### OVERALL DIMENSIONS AND HYDRAULIC SYMBOL

Fixing screws M6x100 UNI 5931

Pay attention please, max tightening torque for manometer (M2): 35 Nm / 3,5 Kgm

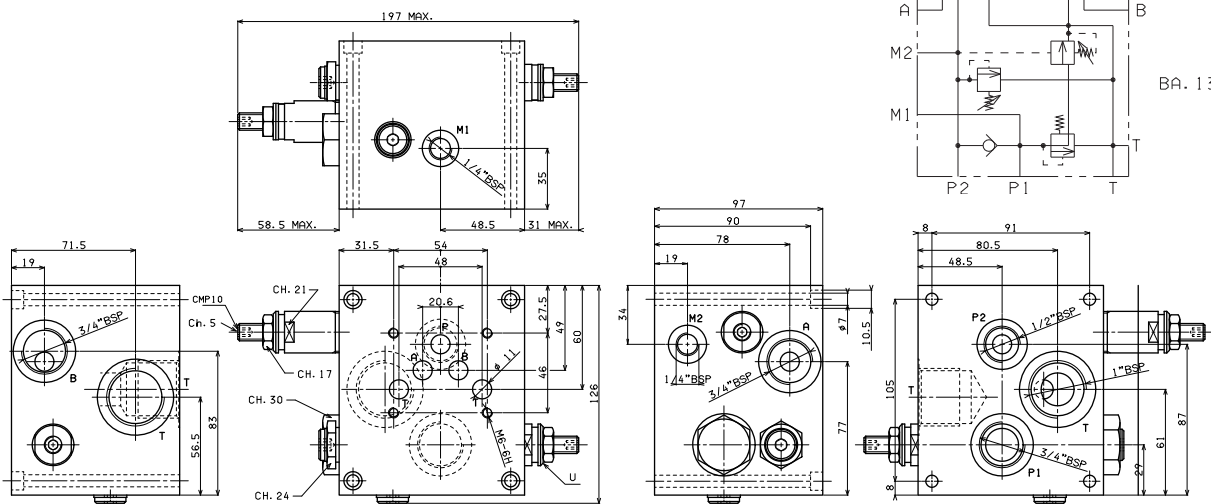

10

# BA130... Low / HIGH PRESSURE UNITS

## OVERALL DIMENSIONS AND HYDRAULIC SYMBOLS

### SIDE MOUNTING FOR SINGLE SOLENOID VALVE CETOP5/NG10 (CONNECTOR BLOCK BA1062)

Fixing screws M10x80 UNI 5931

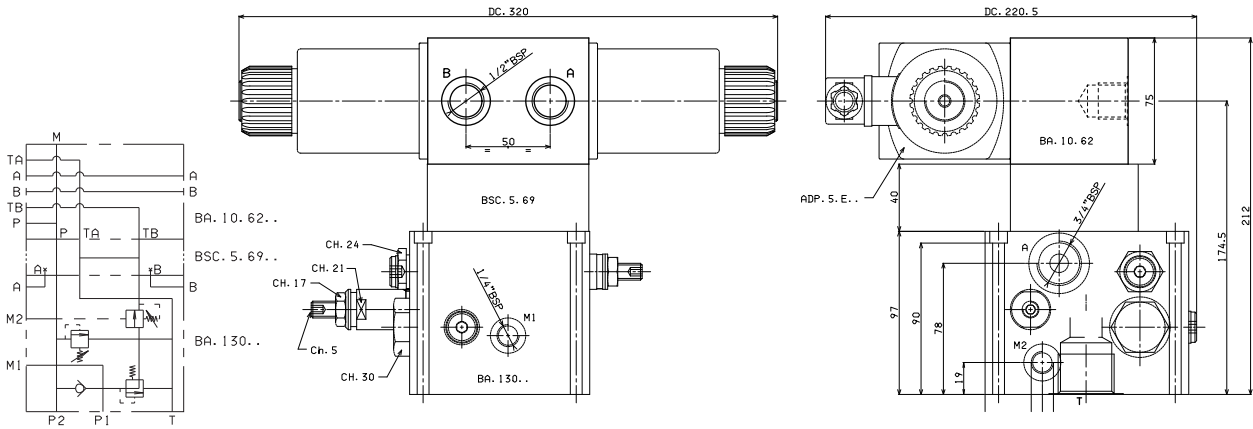

### UPPER MOUNTING FOR SINGLE SOLENOID VALVE CETOP5/NG10

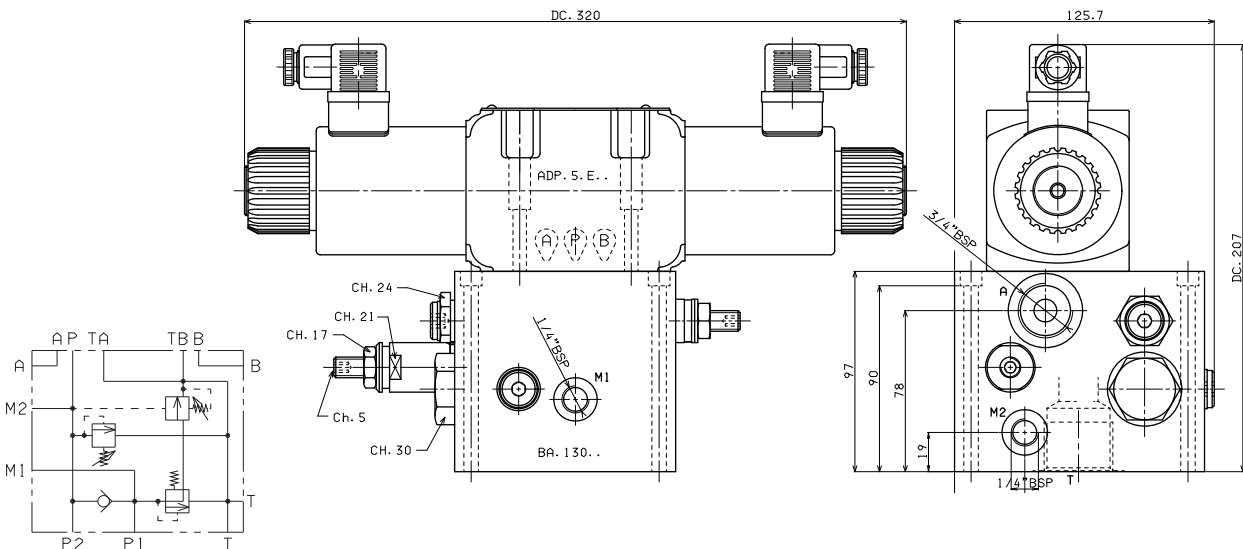

### MOUNTING WITH THREADED CONNECTORS (CONNECTOR BLOCK BA1068)

Fixing screws M10x45 UNI 5931

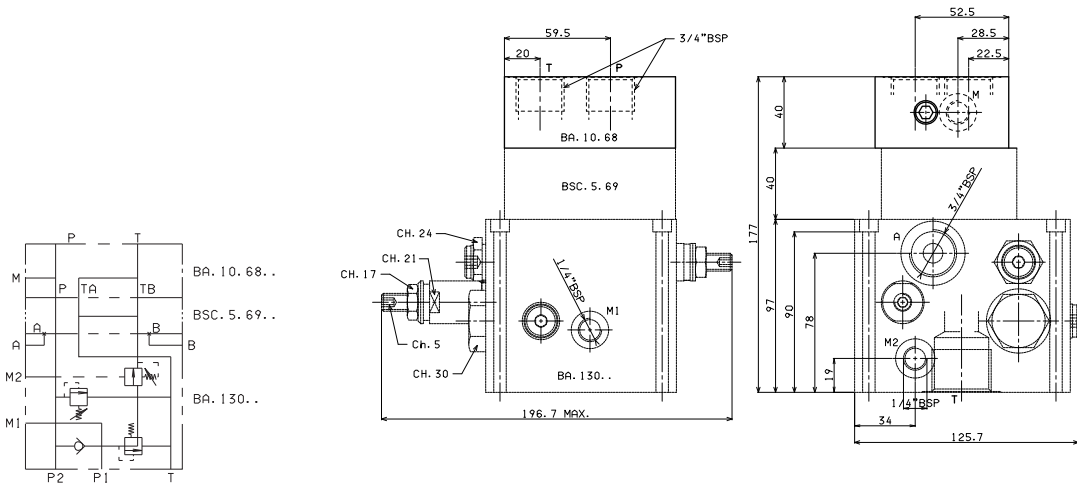

10

# BA130... Low / HIGH PRESSURE UNITS

## OVERALL DIMENSIONS AND HYDRAULIC SYMBOL

### MULTIPLE MOUNTING WITH MODULAR COMPONENT CONNECTOR BLOCKS CONNECTED IN SERIES OR PARALLEL CETOP5/NG10

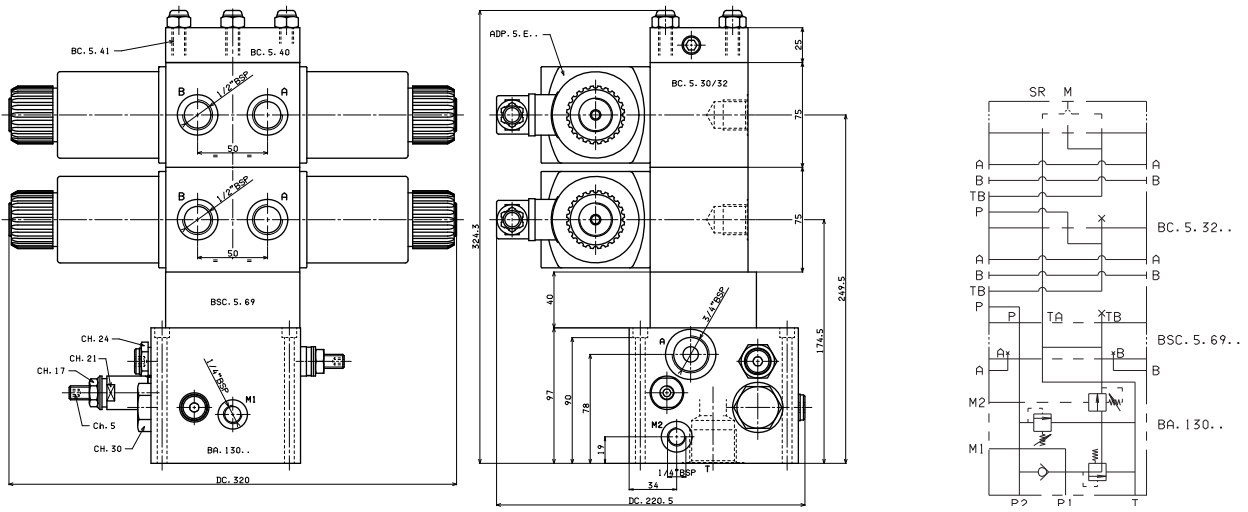

## BSC569... TRANSFORMATION MOUNTING CETOP 5 INTERFACE TO MODULAR COMPONENT BC5...

- BSC** Modular component subplate
- 5** CETOP 5/NG10
- 69** Type of module: to modular component BC5
- 00** No variant
- 1** Serial No.

Fixing screws M6x35 UNI 5931  
Weight 2,1 Kg

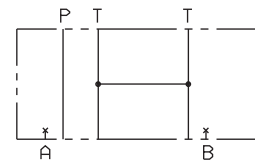

BSC. 5. 69..

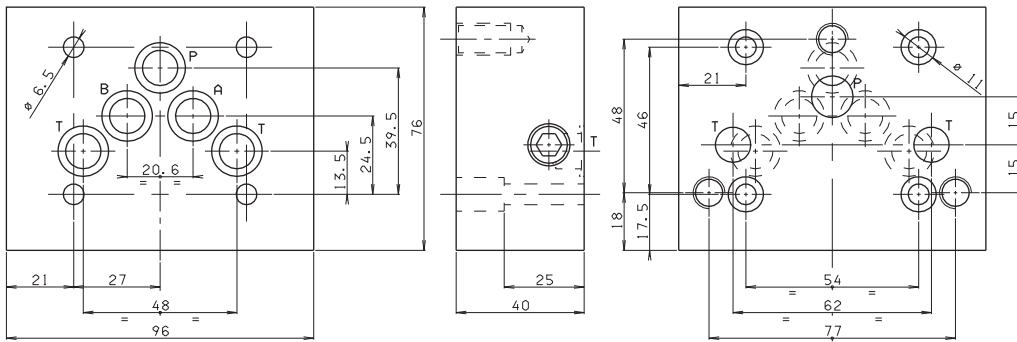

## BS5RGA... / BS5RIA... SPECIAL SUBPLATE MOUNTINGS WITH AUTOMATIC EXCLUSION REGENERATING CIRCUIT



**BS5RGA... / BS5RIA...**

AD5I... CAP. I • 47

These special subplates, with relief valve, have integrated a regenerative circuit which disengages automatically with increasing load.

This circuit allows a fast movement of the cylinder with low working pressure followed by an automatic disengagement of the regenerative function at the set pressure, consequent a higher hydraulic force is available.

Furthermore in the BS5RIA version the automatic reciprocating valve allows a continuous movement of the cylinder till the stop of the pump.

The reciprocating valve has a preferential position which allows the cylinder to begin always in the same position at the start of the working cycle (P → B).

This systems are particularly useful for garbage compactors or small presses.

Max. pump flow (suggested)	30 l/min
Max. flow with regenerative connected	100 l/min
Max. operating pressure (relief valve)	350 bar
Max. operating pressure (exclusion)	200 bar
Hydraulic fluids	Mineral oils DIN 51524
Fluid viscosity	10 ÷ 500 mm <sup>2</sup> /s
Fluid temperature	-25°C ÷ 75°C
Ambient temperature	-25°C ÷ 60°C
Max. contamination level	class 10 in accordance with NAS 1638 with filter $\beta_{25} \geq 75$
Weight BS5RGA... version	Kg 5,7
Weight BS5RIA... version	Kg 9,4

### TYPICAL INSTALLATION VALUES

- Cylinder area ratio ( $\alpha$ ) **1,6 : 1**
- Pump flow (QP) **30 l/min**
- Type of oil **46 cSt a 40°**
- Regenerative flow (QR)
  - 80 l/min** (for RGA standard subplate)
  - 75 l/min** (for RIA standard subplate)
- Min. exclusion pressure setting **70 bar**
- Max exclusion pressure setting **200 bar**
- Exclusion pressure drops **6 bar**

### ORDERING CODE

- BS** Single subplate mounting
- 5** CETOP 5/NG10
- \*\*\*** **RGA** = Automatic exclusion regenerating circuit with presetting for AD5E...
- RIA** = Automatic exclusion regenerating circuit with AD5IP2T.1 included
- U3** Exclusion range 20 ÷ 200 - see note (\*)
- \*** Adjustment (relief valve)
  - M** = Plastic knob
  - C** = Grub screw
- \*** Max relief setting ranges
  - 2** = max. 140 bar (**yellow spring**)
  - 3** = max. 350 bar (**green spring**)
- \*\*** **00** = No variant
- 2** Serial No

(\*) These values depend on the hydraulic circuit configuration: flow, dimensions and system's frictions.

### HYDRAULIC SYMBOLS

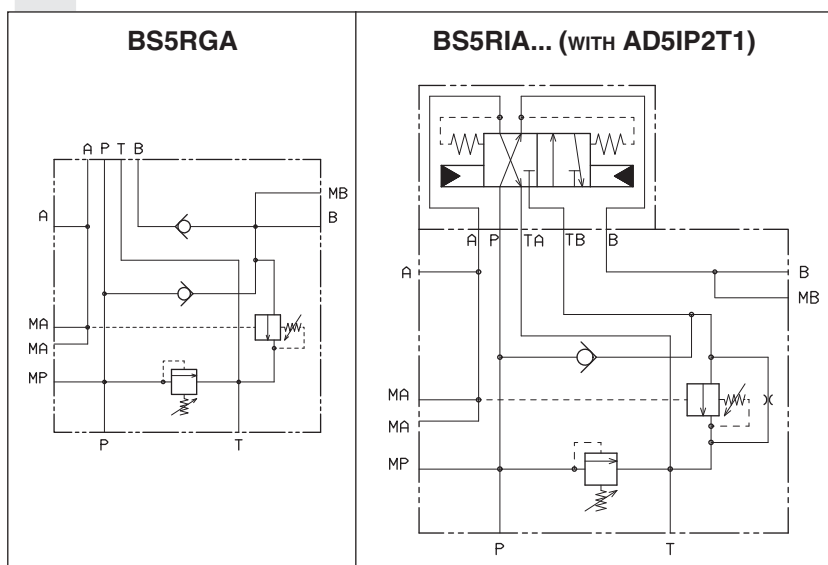

### TYPICAL INSTALLATION FOR BS5RGA

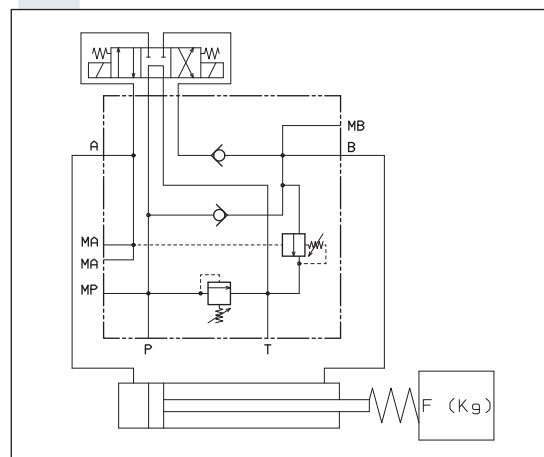

# BS5RGA... / BS5RIA... SPECIAL SUBPLATE MOUNTINGS WITH AUTOMATIC EXCLUSION REGENERATING CIRCUIT

## OVERALL DIMENSIONS

### BS5RGA...

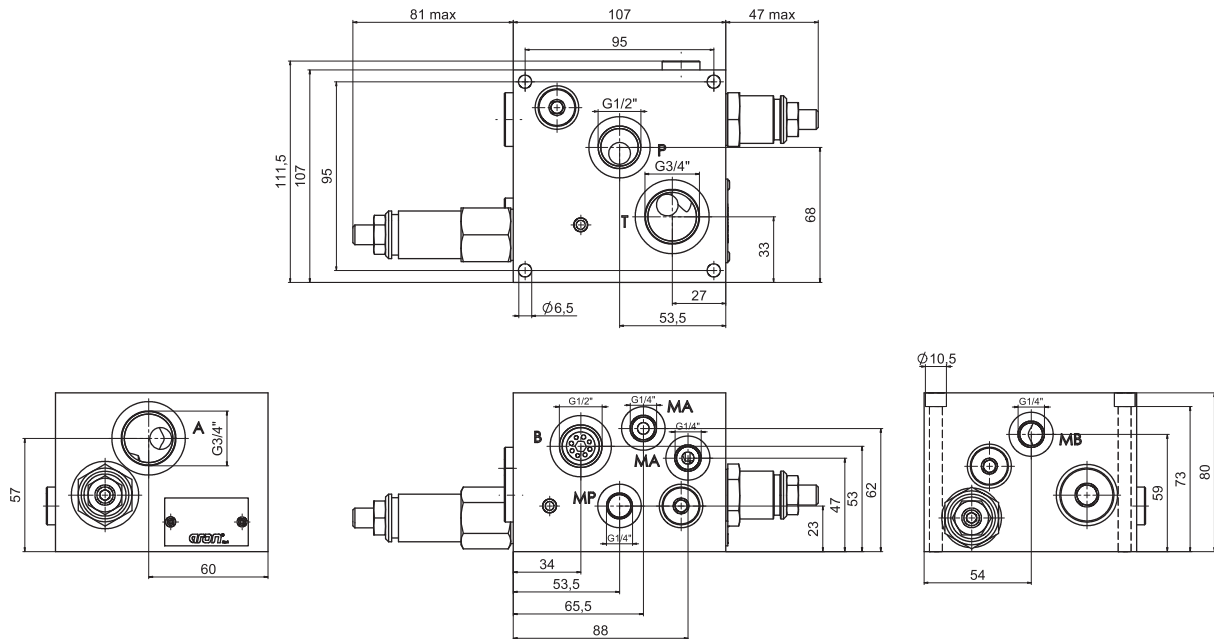

### BS5RIA... WITH AD5IP2T1

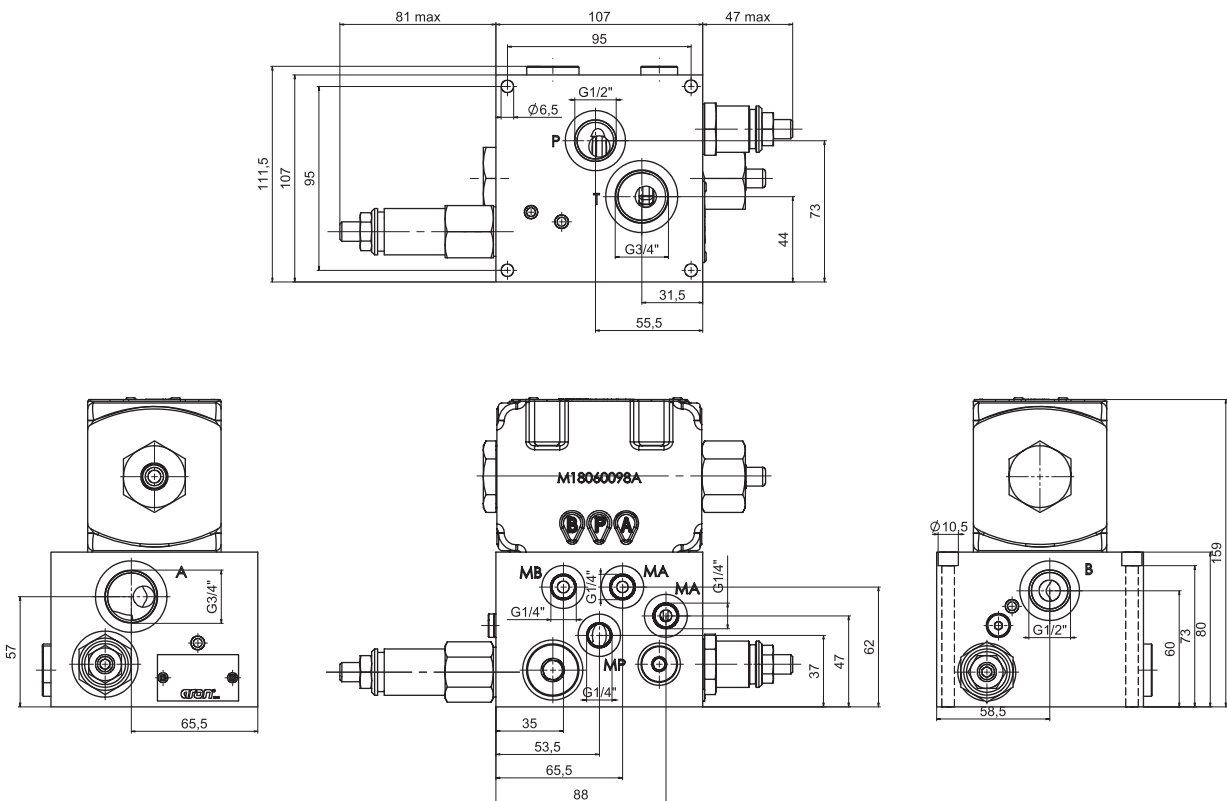





## ABBREVIATIONS

<b>AP</b>	HIGH PRESSURE CONNECTION
<b>AS</b>	PHASE LAG (DEGREES)
<b>BP</b>	LOW PRESSURE CONNECTION
<b>C</b>	STROKE (MM)
<b>CH</b>	ACROSS FLATS
<b>Ch</b>	INTERNAL ACROSS FLATS
<b>DA</b>	AMPLITUDE DECAY (DB)
<b>DP</b>	DIFFERENTIAL PRESSURE (BAR)
<b>F</b>	FORCE (N)
<b>I%</b>	INPUT CURRENT (A)
<b>M</b>	MANOMETER CONNECTION
<b>NG</b>	KNOB TURNS
<b>OR</b>	SEAL RING
<b>P</b>	LOAD PRESSURE (BAR)
<b>PARBAK</b>	PARBAK RING
<b>PL</b>	PARALLEL CONNECTION
<b>Pr</b>	REDUCED PRESSURE (BAR)
<b>Q</b>	FLOW (L/MIN)
<b>QP</b>	PUMP FLOW (L/MIN)
<b>SE</b>	ELASTIC PIN
<b>SF</b>	BALL
<b>SR</b>	SERIES CONNECTION
<b>X</b>	PILOTING
<b>Y</b>	DRAINAGE

## COMPENSATED BANKABLE VALVES

SEE CATALOGUE  
CODE **DOC00046**



## STANDARD COILS

### ABBREVIATIONS

<b>AP</b>	HIGH PRESSURE CONNECTION
<b>AS</b>	PHASE LAG (DEGREES)
<b>BP</b>	LOW PRESSURE CONNECTION
<b>C</b>	STROKE (MM)
<b>CH</b>	ACROSS FLATS
<b>Ch</b>	INTERNAL ACROSS FLATS
<b>DA</b>	AMPLITUDE DECAY (dB)
<b>DP</b>	DIFFERENTIAL PRESSURE (BAR)
<b>F</b>	FORCE (N)
<b>I%</b>	INPUT CURRENT (A)
<b>M</b>	MANOMETER CONNECTION
<b>NG</b>	KNOB TURNS
<b>OR</b>	SEAL RING
<b>P</b>	LOAD PRESSURE (BAR)
<b>PARBAK</b>	PARBAK RING
<b>PL</b>	PARALLEL CONNECTION
<b>Pr</b>	REDUCED PRESSURE (BAR)
<b>Q</b>	FLOW (L/MIN)
<b>Qp</b>	PUMP FLOW (L/MIN)
<b>SE</b>	ELASTIC PIN
<b>SF</b>	BALL
<b>SR</b>	SERIES CONNECTION
<b>X</b>	PILOTING
<b>Y</b>	DRAINAGE

### DC AND AC STANDARD COILS "UL RECOGNIZED" TYPE COILS



A09 DC COIL	CAP. XII • 2
20W DC COIL	CAP. XII • 3
D15 DC COIL	CAP. XII • 4
ECoAT D15 DC COIL	CAP. XII • 5
40W COIL	CAP. XII • 6
B14 AC SOLENOID	CAP. XII • 7
A16 DC COIL	CAP. XII • 8
D19 DC SOLENOID	CAP. XII • 9
K16 AC SOLENOID	CAP. XII • 10
22W DC COIL (FOR CARTRIDGE VALVE)	CAP. XII • 11
30W DC COIL (FOR CARTRIDGE VALVES)	CAP. XII • 12
UL RECOGNIZED COILS	CAP. XII • 13



## A09 DC COILS

Type of protection (in relation to connector used)	IP 65
Number of cycle	18.000/h
Supply tolerance	±10%
Ambient temperature	-30°C ÷ 60°C
Duty cycle	100% ED
Insulation class wire	H
Weight	0,215 Kg

### MOUNTING COMPATIBILITY

<b>AD2E</b>	CAP. I • 4
<b>ADC3...</b>	CAP. I • 7
<b>CDL04...</b>	CAP. I • 66

VOLTAGE (V)	MAX WINDING TEMPERATURE (AMBIENT TEMPERATURE 25°C)	RATED POWER (W)	RESISTANCE AT 20°C (OHM) ±7%
12V	123°C	27	5.3
24V	123°C	27	21.3
48V*	123°C	27	85.3
102V**(**)	123°C	27	392
110V**(**)	123°C	27	448
205V**(**)	123°C	27	1577

\* Special voltages

\*\* The european low voltage directive is applied to electrical equipments used at a nominal voltages between 50 and 1000 VAC or 75 and 1500 VDC. In conformity with the low directive each part of the manifold or the subplate on which the valve is mounted should be connected to a protective earth with a resistance less than 0.1 ohms.

### AMP JUNIOR (AJ)

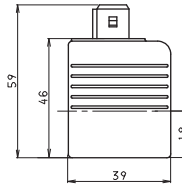

### DEUTSCH COIL + BIDIR. DIODE (CX) DT04 - 2P

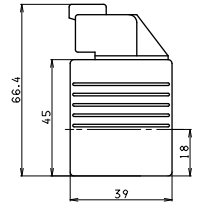

### ES MANUAL EMERGENCY

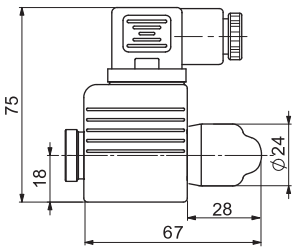

### P2(\*) ROTARY EMERGENCY

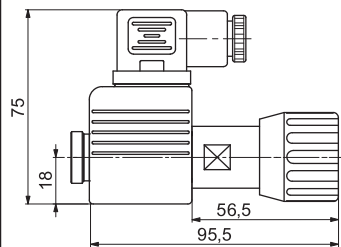

### R5(\*) ROTARY EMERGENCY 180°

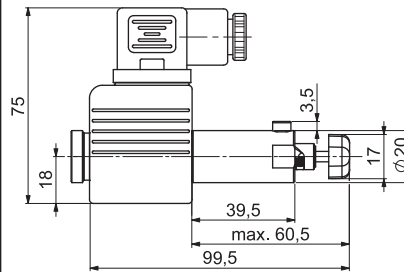

### FLYING LEADS (FL) LEADS + DIODE (LD)

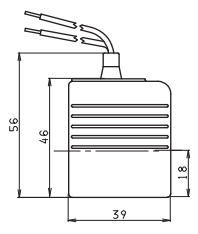

## SPARE PARTS

(\*) P2 and R5 Emergency tightening torque max. 6±9 Nm / 0.6 ÷ 0.9 Kgm with CH n. 22

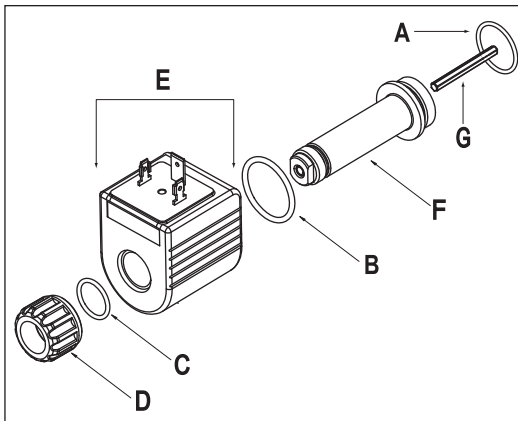

E = SEE A09 COIL TABLE  
A/B/C/D/F/G = SINGLE SPARE PARTS (SEE CODES TABLE)

VOLTAGE	HIRSCHMANN (STANDARD) (00)	CONNECTIONS			
		AMP JUNIOR (AJ)	FLYING LEADS + DIODE (LD) (130)	FLYING LEADS (250) (FL)	DEUTSCH + BIDIR. DIODE (CX)
12 V (L)	M14310001	M14320001	M14330001	M14070011	M14340001
24 V (M)	M14310002	M14320002	M14330002	M14070012	M14340002
48V* (N)	M14310003				
102V* (Z)	M14310008				
110V* (P)	M14310005				
205V* (X)	M14310009				

(\*)SPECIAL VOLTAGES

COMPLETE KIT	AD2E	CDL04	ADC3	CDC3
COMPLETE SOLENOID'S TUBE	V85990008		V85990007	
P2 ROTARY EMERGENCY	V89990016		V89990017	
R5 ROTARY EMERGENCY 180°	-		V15050098	
ES MANUAL EMERGENCY	M19050003			

CODE SPARE PARTS	A	B	C	D	E	F	G	MOUNTING AVAILABES	
AD2E	Q25831023	Q25830096	Q25860013	M37050036	SEE TABLE A09	M83060003	M74490001	C - E - F	
CDL04								M74490002	G - H - I - L
ADC3 / CDC3	Q25830024	Q25860023						M74490003	D - M
C3V03	Q25861025	Q25860024						M74490004	-
				M37050031		M83060004	M74460001	C - E - F	
						M83060002	M74460002	G - H	
							M74480001	-	



## "20W" DC COILS FOR OFF-HIGHWAY MACHINERY

Type of protection (in relation to connector used)	IP 65
Number of cycle	18.000/h
Supply tolerance	±10%
Ambient temperature	-30°C ÷ 60°C
Duty cycle	100% ED
Insulation class wire	H
Weight	0,212 Kg

MOUNTING COMPATIBILITY	
<b>CRD03...</b>	CARTRIDGE CATALOGUE
<b>C3V05...</b>	CARTRIDGE CATALOGUE

VOLTAGE (V)	MAX. WINDING TEMPERATURE (AMBIENT TEMPERATURE 25°C)	RATED POWER (W)	RESISTANCE AT 20°C (OHM) ±10%
12V	-	20	7.2

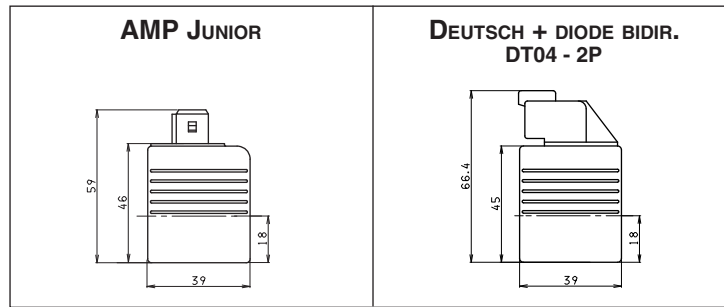

## SPARE PARTS

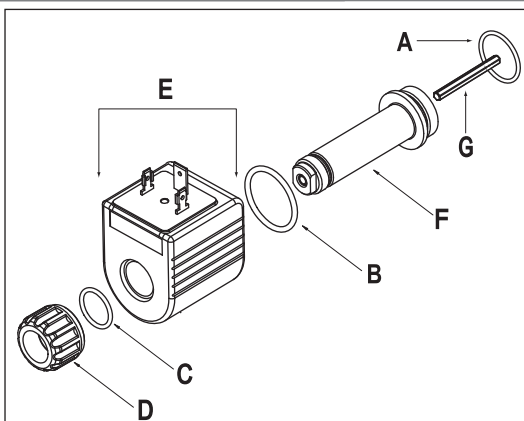

**E** = SEE 20W COIL TABLE  
**A/B/C/D/F/G** = SINGLE SPARE PARTS (SEE CODES TABLE)

20W DC COIL	CONNECTIONS	
	AMP JUNIOR (A)	DEUTSCH + BIDIR. DIODE (D)
TENSIONE		
12V (L)	<b>M14321001</b>	<b>M14341001</b>

CODE SPARE PARTS	A	B	C	D	E	F	G
	O RING			RING NUT	COIL	TUBE	HEX. PUSHROD
CRD03 C3V05	<b>Q25861010</b>	<b>Q25860023</b>	<b>Q25830022</b>	<b>M37050031</b> <b>M37050036</b>	<b>VEDI</b> <b>20W</b>	<b>M83060007</b> <b>M83060006</b>	<b>M74480003</b> <b>M74480002</b>



## "D15" DC COILS FOR CETOP 3

Type of protection (in relation to the connector used)	IP 66
Number of cycles	18.000/h
Supply tolerance	±10%
Ambient temperature	-25°C ÷ 60°C
Duty cycle	100% ED
Insulation class wire	H
Weight	0,354 Kg

### MOUNTING COMPATIBILITY

<b>CETOP 3</b>	CAP. I • 8
<b>AD3E...</b>	CAP. I • 11
<b>AD3V...</b>	CAP. I • 14
<b>ADL06...</b>	CAP. I • 69
<b>A66...</b>	CAP. IV • 19

VOLTAGE (V)	MAX WINDING TEMPERATURE (AMBIENT TEMPERATURE 25°C)	RATED POWER (W)	RESISTANCE AT 20°C (OHM) ±10%
12V	110°C	30	4.8
24V	110°C	30	18.8
28V*	110°C	30	25.6
48V*	110°C	30	75.2
102V*(**)	110°C	30	340
110V*(**)	110°C	30	387
205V*(**)	110°C	30	1375

\* Special voltages

\*\* The european low voltage directive is applied to electrical equipments used at a nominal voltages between 50 and 1000 VAC or 75 and 1500 VDC. In conformity with the low directive each part of the manifold or the subplate on which the valve is mounted should be connected to a protective earth with a resistance less than 0.1 ohms.

### eCOAT COIL (RS)

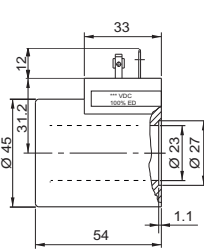

SEE THE FOLLOWING PAGE

### ES MANUAL EMERGENCY

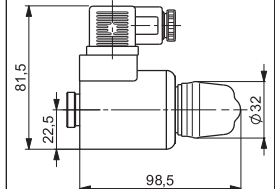

### FLYING LEADS (SL)

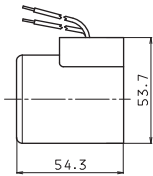

### AMP JUNIOR (AJ) AJ + DIODE (AD)

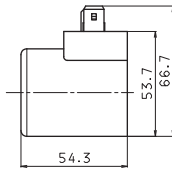

### DEUTSCH DT04 - 2P (CZ) CZ + eCOAT (R6)

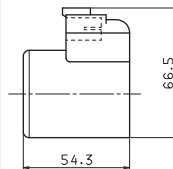

### P2 ROTARY EMERGENCY

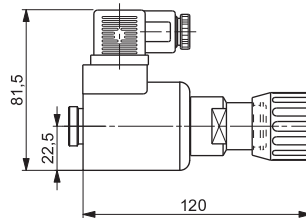

### R5 ROTARY EMERGENCY 180°

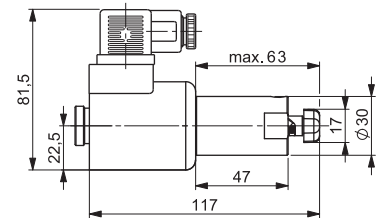

## SPARE PARTS

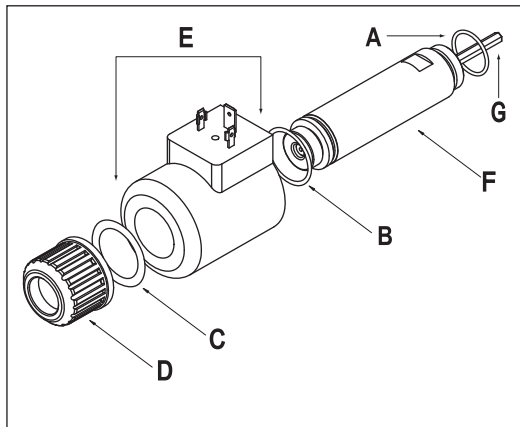

E = SEE D15 COIL TABLE  
A/B/C/D/F/G = SINGLE SPARE PARTS (SEE CODES TABLE)

VOLTAGE	D15 DC - 30W COIL CONNECTIONS				
	HIRSCHMANN (STANDARD) (00)	AMP JUNIOR (AJ)	AMP JUNIOR + DIODE (AD)	FLYING LEADS (175) (SL)	DEUTSCH (CZ)
12V (L)	M14450002	M14460002	M14470002	M14480002	M14490002
24V (M)	M14450004	M14460004	M14470004	M14480004	-
28V* (V)	M14450005				
48V* (N)	M14450006				
102V* (Z)	M14450018				
110V* (P)	M14450008				
205V* (X)	M14450019				

(\*SPECIAL VOLTAGES)

COMPLETE KIT	AD3E	CD3	ADL06	AD3V	A66
COMPLETE SOLENOID'S TUBE	V85990003				
P2 ROTARY EMERGENCY	V89990010				
R5 ROTARY EMERGENCY 180°	V15050097				
ES MANUAL EMERGENCY	M19050004				

CODE SPARE PARTS	A	B	C	D	E	F	G	MOUNTING AVAILABLES
AD3E CD3 AD3V ADL06	Q25830024	Q25860033	Q25830185	M37050030	SEE TABLE D15	M83130001	M74470001 M74470002 M74470003	C - E - F - M G - H - I - L D
A66							M74470004	-

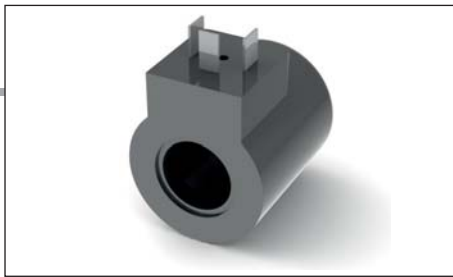

## HIRSCHMANN eCoat<sup>(1)</sup> COILS (D15 RS VARIANT)

Type of protection (in relation to the connector)	IP 66
Number of cycles	18.000/h
Supply tolerance	±10%
Ambient temperature	-25°C ÷ 60°C
Duty cycle	100% ED
Insulation class wire	H
Weight	0,354 Kg

### MOUNTING COMPATIBILITY

<b>CETOP 3</b>	CAP. I • 8
<b>AD3E...</b>	CAP. I • 11
<b>ADL06...</b>	CAP. I • 69

VOLTAGE (V)	MAX. WINDING TEMPERATURE (AMBIENT TEMPERATURE 25°C)	RATED POWER (W)	RESISTANCE AT 20°C (OHM) ±10%
12V	110°C	30	4.8
24V	110°C	30	18.8
28V*	110°C	30	25.6
110V>(*)(**)	110°C	30	387

\* Special voltages

(1) Sealed coil winding with steel out housing with eCoat protection. Has successfully overcome more than 700 hours of salt spray test before red rust (test according to UNI EN ISO 9227 and test evaluation according to UNI EN ISO 10289).

\*\* The european low voltage directive is applied to electrical equipments used at a nominal voltages between 50 and 1000 VAC or 75 and 1500 VDC. In conformity with the low directive each part of the manifold or the subplate on which the valve is mounted should be connected to a protective earth with a resistance less than 0.1 ohms.

## SPARE PARTS

D15 eCoat COIL (DC / 30W)	
VOLTAGE	HIRSCHMANN (STANDARD)
12V (L)	<b>M14820001</b>
24V (M)	<b>M14820002</b>
28V* (V)	<b>M14820005</b>
110V* (P)	<b>M14820008</b>

(\*)SPECIAL VOLTAGES

CODE SPARE PARTS B / C / D / E / F / G	FOR RS VARIANT
<b>B</b> OR (TUBE)	<b>Q25830024</b>
<b>C</b> RING NUT	<b>M37050062</b>
<b>D</b> O RING (RING NUT)	<b>Q25830185</b>
<b>E</b> O RING (COIL)	<b>Q25860033</b>
<b>F</b> TUBE	<b>M83130001</b>
<b>G</b> HEX. PUSHROD (MOUNTING C-E-F) (MOUNTING G-H-I) (MOUNTING D)	<b>M74470001</b> <b>M74470002</b> <b>M74470003</b>

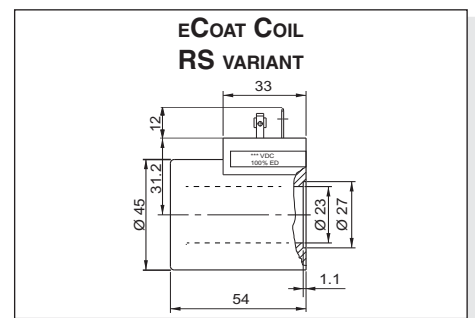

SEE "D15" COIL STANDARD FOR BOTH EMERGENCY MANUAL ES AND ROTARY P2.



## DEUTSCH eCoat<sup>(1)</sup> COILS (D15 R6 VARIANT)

Type of protection (in relation to the connector)	IP 69K
Number of cycles	18.000/h
Supply tolerance	±10%
Ambient temperature	-20°C ÷ 60°C
Duty cycle	100% ED
Insulation class wire	H
Weight	0,354 Kg

### MOUNTING COMPATIBILITY

<b>CETOP 3</b>	CAP. I • 8
<b>AD3E...</b>	CAP. I • 11
<b>ADL06...</b>	CAP. I • 69

VOLTAGE (V)	MAX. WINDING TEMPERATURE (AMBIENT TEMPERATURE 25°C)	RATED POWER (W)	RESISTANCE AT 20°C (OHM) ±10%
12V	110°C	30	4.8
24V	110°C	30	18.8

(1) Sealed coil winding with steel out housing with eCoat protection. Has successfully overcome more than 700 hours of salt spray test before red rust (test according to UNI EN ISO 9227 and test evaluation according to UNI EN ISO 10289).

## SPARE PARTS

D15 eCoat COIL (DC / 30W)	
TENSIONE	DEUTSCH
12V (L)	<b>M14830001</b>
24V (M)	<b>M14830002</b>

CODE SPARE PARTS B / C / D / E / F / G	FOR R6 VARIANT
<b>B</b> OR (TUBE)	<b>Q25830024</b>
<b>C</b> RING NUT	<b>M37050062</b>
<b>D</b> O RING (RING NUT)	<b>Q25830185</b>
<b>E</b> O RING (COIL)	<b>Q25860033</b>
<b>F</b> TUBE	<b>M83130001</b>
<b>G</b> HEX. PUSHROD (MOUNTING C-E-F) (MOUNTING G-H-I) (MOUNTING D)	<b>M74470001</b> <b>M74470002</b> <b>M74470003</b>

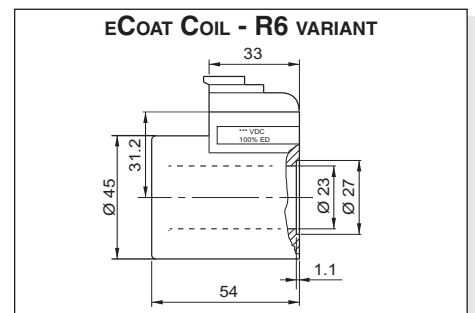

SEE "D15" COIL STANDARD FOR BOTH EMERGENCY MANUAL ES AND ROTARY P2.

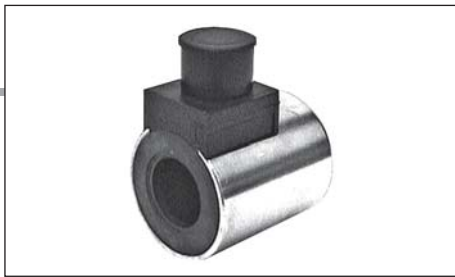

## "40W" DC COIL (FOR CDL.06...)

Type of protection (in relation to the connector)	IP 66
Number of cycles	18.000/h
Supply tolerance	±10%
Ambient temperature	-54°C ÷ 60°C
Duty cycle	100% ED
Insulation class wire	H
Weight	0,354 Kg

### MOUNTING COMPATIBILITY

CDL06...	CAP. I • 68
----------	-------------

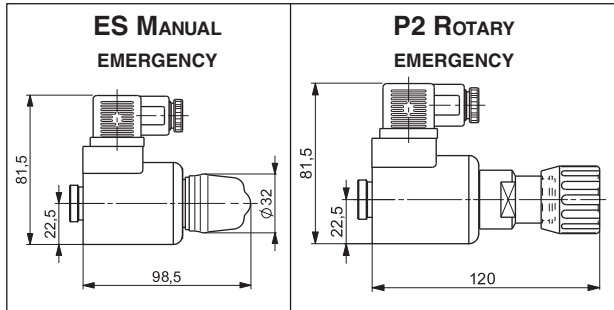

VOLTAGE (V)	MAX. WINDING TEMPERATURE (AMBIENT TEMPERATURE 25°C)	RATED POWER (W)	RESISTANCE AT 20°C (OHM) ±10%
12V	135°C	40	3.6
24V	135°C	40	14.4

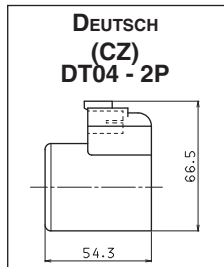

COMPLETE KIT	CDL06
P2 ROTARY EMERGENCY	V89990010
ES MANUAL EMERGENCY	M19050004

## SPARE PARTS

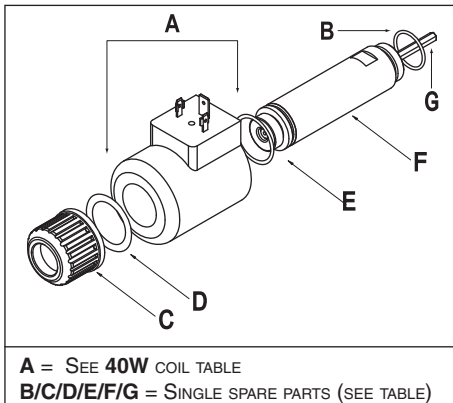

40W DC COIL	CONNECTIONS
VOLTAGE	HIRSCHMANN (STANDARD)
12V (L)	<b>M14600001</b>
24V (M)	<b>M14600002</b>
	DEUTSCH (CZ)
12V (L)	<b>M14610001</b>
24V (M)	<b>M14610002</b>

CODE SPARE PARTS B/C/D/E/F/G	FOR CDL06
<b>B</b> O RING (TUBE)	<b>Q25830024</b>
<b>C</b> RING NUT	<b>M37050030</b>
<b>D</b> O RING (RING NUT)	<b>Q25830185</b>
<b>E</b> O RING (COIL)	<b>Q25860033</b>
<b>F</b> TUBE	<b>M83130001</b>
<b>G</b> HEX. PUSHROD	<b>M74470003</b>





## "B14" AC SOLENOIDS FOR CETOP 3

Type of protection (in relation to the connector used)	IP 65
Number of cycles	18.000/h
Supply tolerance	+10% / -10%
Ambient temperature	-30°C ÷ 60°C
Duty cycle	100% ED
Insulation class wire	H
Weight	0,436 Kg

MOUNTING COMPATIBILITY	
<b>CETOP 3 *</b>	CAP. I • 8
<b>AD3.E... *</b>	CAP. I • 11

(\* ) serial No. 3 (AC voltage)

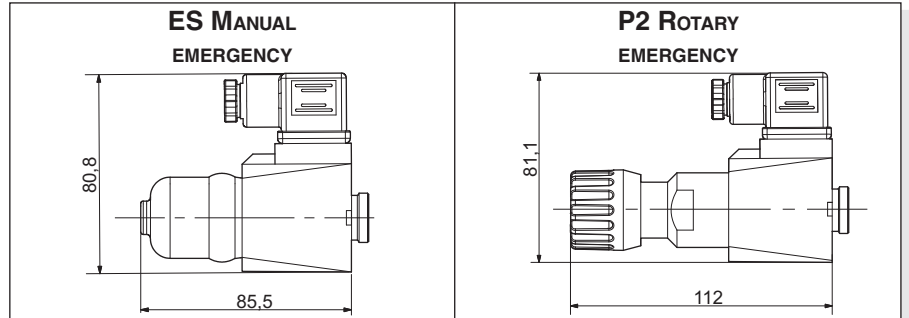

VOLTAGE (V)	MAX. WINDING TEMPERATURE (AMBIENT TEMPERATURE 25°C)	RESISTANCE AT 20°C (OHM) ±10%	RATED POWER (VA)	PICKUP CURRENT (A)
24V/50Hz - 24V/60Hz	100°C - 96°C	1.7	54 - 40	5.6 - 5
48V/50Hz - 48V/60Hz	112°C - 98°C	6.8	45 - 34	5.3 - 5
115V/50Hz - 120V/60Hz *	133°C - 101°C	32.5	61 - 51	3.2 - 3.2
230V/50Hz - 240V/60Hz *	120°C - 103°C	134	62 - 52	1.6 - 1.6

\* The european low voltage directive is applied to electrical equipments used at a nominal voltages between 50 and 1000 VAC or 75 and 1500 VDC. In conformity with the low directive each part of the manifold or the subplate on which the valve is mounted should be connected to a protective earth with a resistance less than 0.1 ohms.

## SPARE PARTS

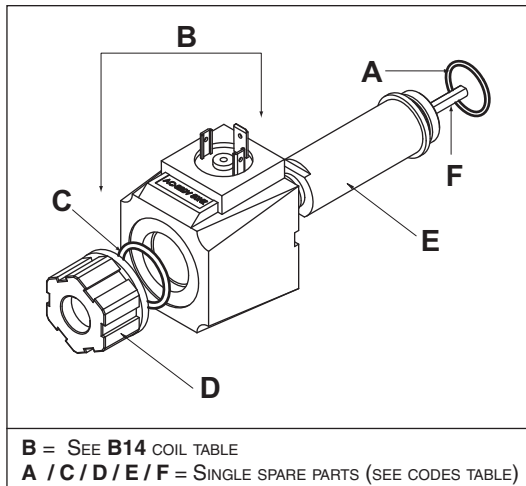

B14 AC COIL	CONNECTION
<b>VOLTAGE</b>	HIRSCHMANN (STANDARD)
24V/50-60Hz (A)	<b>M14640003</b>
48V/50-60Hz (B)	<b>M14640007</b>
115V/50Hz (J)	<b>M14640006</b>
120V/60Hz	
230V/50Hz (Y)	<b>M14640001</b>
240V/60Hz	
COMPLETE KIT	CODE
TUBE KIT	<b>V85990011</b>
ROTARY EMERGENCY <b>P2</b>	<b>V89990021</b>
MANUAL EMERGENCY <b>ES</b>	<b>M19050001</b>

CODE SPARE PARTS	A	B	C	D	E	F	MONTAGGI POSSIBILI
	O RING	COIL	O RING	RING NUT	TUBE	HEX. PUSHROD	
AD3E*	<b>Q25830024</b>	SEE TABLE <b>B14</b>	<b>Q25860036</b>	<b>M37050041</b>	<b>M831100001</b>	<b>M74520001</b> <b>M74520002</b> <b>M74520003</b>	C - E - F - M G - H - I - L D

(\* ) serial No. 3 (AC voltage)



## "A16" DC COILS FOR CETOP 5

Type of protection (in relation to the connector used)	IP 65
Number of cycles	18.000/h
Supply tolerance	±10%
Ambient temperature	-30°C ÷ 60°C
Duty cycle	100% ED
Insulation class wire	H
Weight	0,9 Kg

MOUNTING COMPATIBILITY	
<b>CETOP 5</b>	CAP. I • 33
<b>AD5E...</b>	CAP. I • 36
<b>CDL10...</b>	CAP. I • 71
<b>ADL106...</b>	CAP. I • 72
<b>A88...</b>	CAP. IV • 33

VOLTAGE (V)	MAX WINDING TEMPERATURE (AMBIENT TEMPERATURE 25°C)	RATED POWER (W)	RESISTANCE AT 20°C (OHM) ±7%
12V	106°C	45	3.2
24V	113°C	45	12.4
48V*	-	45	-
102V*(**)	-	45	-
110V*(**)	118°C	45	268
205V*(**)	-	45	-

\* Special voltages

\*\* The european low voltage directive is applied to electrical equipments used at a nominal voltages between 50 and 1000 VAC or 75 and 1500 VDC. In conformity with the low directive each part of the manifold or the subplate on which the valve is mounted should be connected to a protective earth with a resistance less than 0.1 ohms.

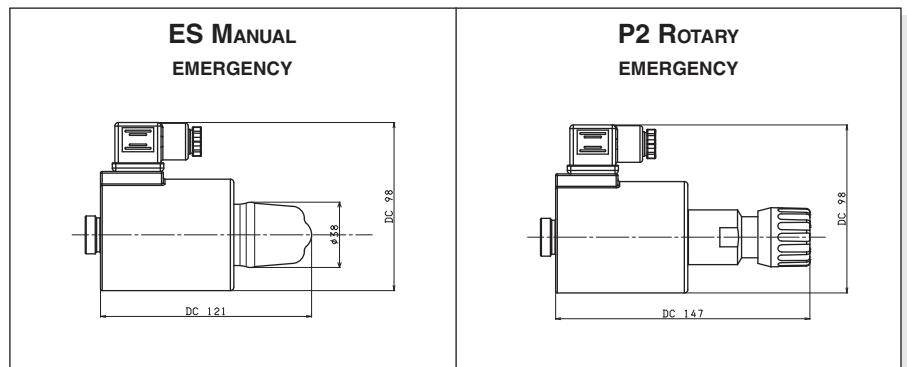

## SPARE PARTS

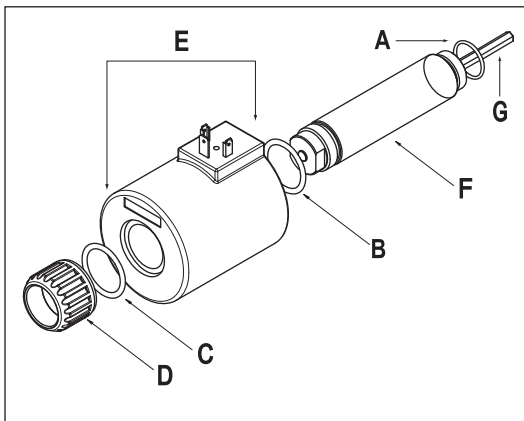

E = SEE A16 COIL TABLE  
A/B/C/D/F/G = SINGLE SPARE PARTS (SEE CODES TABLE)

A16 DC/45W COIL	CONNECTION
VOLTAGE	HIRSCHMANN (STANDARD)
12V (L)	<b>M14220002</b>
24V (M)	<b>M14220004</b>
48V* (N)	<b>M14220006</b>
102V* (Z)	<b>M14220013</b>
110V* (P)	<b>M14220008</b>
205V* (X)	<b>M14220014</b>
(*)SPECIAL VOLTAGES	

COMPLETE KIT	AD5E	CDL10	ADL10	A88
P2 ROTARY EMERGENCY	<b>V89990011</b>			-
ES MANUAL EMERGENCY	<b>M19050002</b>			-

12

CODE SPARE PARTS	A	B	C	D	E	F	G	MOUNTING POSSIBLE
	O RING			RING NUT	COIL	TUBE	HEX. PUSHROD	
AD5E ADL/CDL10	<b>Q25830026</b>	<b>Q25860040</b>	<b>Q25860040</b>	<b>M37050033</b>	SEE TABLE <b>A15</b>	<b>M83160001</b>	<b>M74440002</b>	C - E - F - M G - H - I - L D
							<b>M74440003</b>	
							<b>M74440004</b>	
A88							<b>M74440006</b>	-



## "D19" DC SOLENOIDS

Type of protection (in relation to the connector used)	IP 66
Number of cycle	18.000/h
Supply tolerance	±10%
Ambient temperature	-25°C ÷ 60°C
Duty cycle	100% ED
Max static pressure	210 bar
Insulation class wire	H
Weight	1,63 Kg

### MOUNTING COMPATIBILITY

<b>ADP5E...</b>	CAP. I • 41
<b>ADP5V...</b>	CAP. I • 44

VOLTAGE (V)	MAX WINDING TEMPERATURE (AMBIENT TEMPERATURE 25°C)	RATED POWER (W)	RESISTANCE AT 20°C (OHM) ±10%
12V	105°C	42	3.43
24V	105°C	42	13.71
48V*	105°C	42	55
102V*(**)	105°C	42	248
110V*(**)	105°C	42	288
205V*(**)	105°C	42	1000

\* Special voltage

\*\* The european low voltage directive is applied to electrical equipments used at a nominal voltages between 50 and 1000 VAC or 75 and 1500 VDC. In conformity with the low directive each part of the manifold or the subplate on which the valve is mounted should be connected to a protective earth with a resistance less than 0.1 ohms.

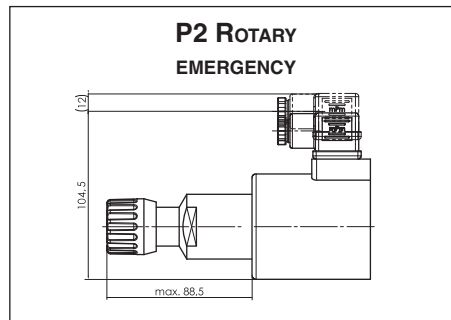

## SPARE PARTS

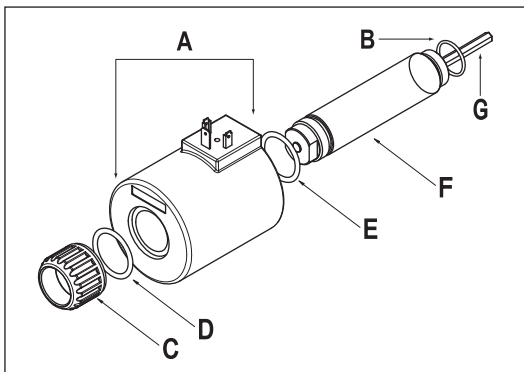

**A** = SEE **D19** COIL TABLE  
**B/C/D/E/F/G** = SINGLE SPARE PARTS (SEE CODES TABLE)

COMPLETE KIT	ADP5E	ADP5V
<b>P2 ROTARY EMERGENCY</b>	<b>V89990012</b>	

D19 DC/42W COIL	CONNECTION
<b>VOLTAGE</b>	HIRSCHMANN (STANDARD)
12V (L)	<b>M14270001</b>
24V (M)	<b>M14270002</b>
48V* (N)	<b>M14270003</b>
102V* (Z)	<b>M14270007</b>
110V* (P)	<b>M14270005</b>
205V* (X)	<b>M14270008</b>
(*)SPECIAL VOLTAGES	

CODE SPARE PARTS B / C / D / E / F / G	FOR ADP5E AND ADP5V
<b>B</b> O RING (TUBE)	<b>Q25830101</b>
<b>C</b> RING NUT	<b>M37050022</b>
<b>D</b> O RING (RING NUT)	<b>Q25830035</b>
<b>E</b> O RING (COIL)	<b>Q25860035</b>
<b>F</b> TUBE	<b>M83170002</b>
<b>G</b> HEX. PUSHROD	<b>M74380002</b>

12



## "K16" AC SOLENOIDS FOR CETOP 5

Type of protection (in relation to the connector used)	IP 66
Number of cycles	18.000/h
Supply tolerance	+10% / -10%
Ambient temperature	-54°C ÷ 60°C
Duty cycle	100% ED
Max. pressure static	210 bar
Insulation class wire	H
Weight	0,8 Kg

MOUNTING COMPATIBILITY	
<b>CETOP 5</b>	CAP. I • 33
<b>AD5.E...</b>	CAP. I • 36

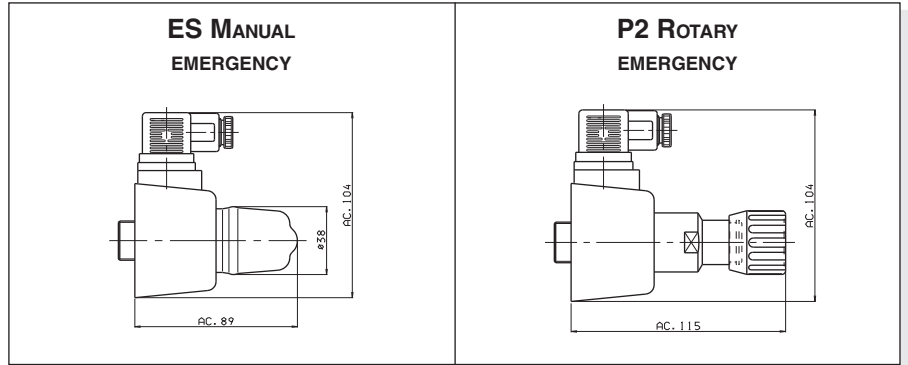

VOLTAGE (V)	MAX. WINDING TEMPERATURE (AMBIENT TEMPERATURE 25°C)	RATED POWER (VA)	IN RUSH CURRENT (VA)	RESISTANCE AT 20°C (OHM) ±10%
24V/50Hz	134°C	124	454	0.56
24V/60Hz*	115°C	103.5	440	0.55
48V/50Hz*	134°C	113	453	2.10
115V/50Hz-120V/60Hz*(**)	121°C - 138°C	121-101	471-487	10.8
230V/50Hz-240V/60Hz*(**)	121°C - 138°C	120-101	478-485	43.0
240V/50Hz*(**)	134°C	120	456	47.39

\*\* The european low voltage directive is applied to electrical equipments used at a nominal voltages between 50 and 1000 VAC or 75 and 1500 VDC. In conformity with the low directive each part of the manifold or the subplate on which the valve is mounted should be connected to a protective earth with a resistance less than 0.1 ohms.

## SPARE PARTS

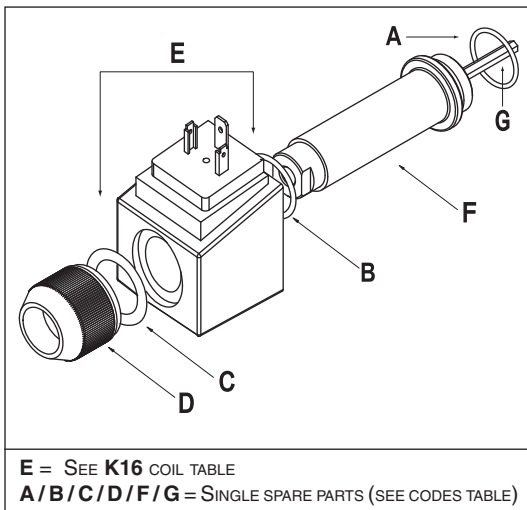

K16 AC COIL	CONNECTION
VOLTAGE	HIRSCHMANN (STANDARD)
24V/50Hz (A)	<b>M14300010</b>
24V/60Hz* (F)	<b>M14300012</b>
48V/50Hz* (B)	<b>M14300014</b>
115V/50Hz (J) 120V/60Hz	<b>M14300029</b>
230V/50Hz (Y) 240V/60Hz	<b>M14300027</b>
240V/50Hz* (E)	<b>M14300025</b>
(*)SPECIAL VOLTAGES	

<b>COMPLETE KIT</b>	AD5E
<b>P2 ROTARY EMERGENCY</b>	<b>V89990002</b>
<b>ES MANUAL EMERGENCY</b>	<b>M19050002</b>

12

CODE SPARE PARTS	A	B	C	D	E	F	G	MOUNTING AVAILABLES
	O RING			RING NUT	COIL	TUBE	HEX. PUSHROD	
AD5E	<b>Q25830026</b>	<b>Q25860026</b>	<b>Q25830187</b>	<b>M37050005</b>	SEE TABLE <b>K15</b>	<b>M83300000</b>	<b>M74210000</b> <b>M74160000</b> <b>M74700000</b>	C - E - F - M G - H - I - L D



## "22W" DC COILS

Type of protection (in relation to the connector)	IP 65
Number of cycles	18.000/h
Supply tolerance	+10% / -10%
Ambient temperature	-30°C ÷ 60°C
Duty cycle	100% ED
Insulation class wire	H
Weight	0,2 Kg

### MOUNTING COMPATIBILITY

<b>CRP/CRD</b>	CARTRIDGE CATALOGUE
<b>C2V02...</b>	CARTRIDGE CATALOGUE

VOLTAGE (V)	MAX. WINDING TEMPERATURE (AMBIENT TEMPERATURE 25°C)	RATED POWER (W)	RESISTANCE AT 20°C (OHM) ±10%
12V	116 °C	22	6.3
24V	115 °C	22	25.6
48V*	114 °C	22	102
102V*(**)	-	22	467.85
205V*(**)	-	22	1954

\* SPECIAL VOLTAGE

\*\* The european low voltage directive is applied to electrical equipments used at a nominal voltages between 50 and 1000 VAC or 75 and 1500 VDC. In conformity with the low directive each part of the manifold or the subplate on which the valve is mounted should be connected to a protective earth with a resistance less than 0.1 ohms.

### PS ROTARY EMERGENCY

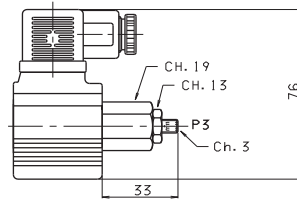

### AMP JUNIOR (AJ)

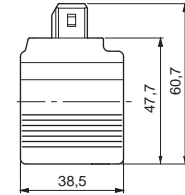

## SPARE PARTS

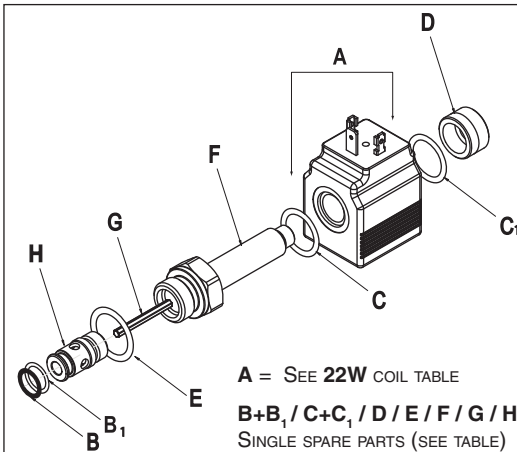

22W DC COIL	CONNECTIONS	
VOLTAGE	STANDARD	AMP JUNIOR (AJ)
12V (L)	<b>M14040001</b>	<b>M14730001</b>
24V (M)	<b>M14040002</b>	<b>M14730002</b>
48V* (N)	<b>M14040003</b>	—
102V* (Z)	<b>M14040006</b>	—
205V* (X)	<b>M14040007</b>	—
(*) SPECIAL VOLTAGES		

COMPLETE KIT	CRP02NA	CRD01/02	CRP02NC	C2V02	C3V02
PS ROTARY EMERGENCY	<b>V89990014</b>	<b>V89990005</b>		-	

CODE SPARE PARTS	B PARBAK	B <sub>1</sub> O RING	C + C <sub>1</sub> O RING (R. NUT/COIL)	C + C <sub>1</sub> RING NUT	E + F TUBE (+ O RING TUBE)	G HEX. PUSHROD	H VALVE SEAT
	VALVE SEAT						
CRP02NC...E			Q25860055	M37050026	<b>R83100B83</b>	<b>M86150006</b>	M70150003
CRP02NC...S	<b>Q25780026</b>	<b>Q25830015</b>			<b>R83100B82</b>	<b>M86150004</b>	
CRP02NA...E					<b>R83100B84</b>	<b>M86150004</b>	
CRD01...A	<b>Q25780026</b>	<b>Q25830015</b>			<b>R83100B85</b>	<b>M74440000</b>	M70150004
CRD01...B	<b>Q25780030</b>	<b>Q25830021</b>				<b>M74440000</b>	M70150005
CRD02...A	<b>Q25780026</b>	<b>Q25830015</b>				<b>M74440001</b>	M70150004
CRD02...B	<b>Q25780030</b>	<b>Q25830021</b>	<b>M74440001</b>	M70150005			

CODE SPARE PARTS	B PARBAK	B <sub>1</sub> O RING	C + C <sub>1</sub> O RING (R. NUT/COIL)	C + C <sub>1</sub> RING NUT	E O RING (TUBE)	F TUBE	G HEX. PUSHROD	H VALVE SEAT
	VALVE SEAT							
C2V02NC...			Q25860055	M37050026	Q25861010	M83040005	<b>M50070002</b>	M70400002
C2V02NA...	<b>Q25780026</b>	<b>Q25830015</b>					<b>M50070003</b>	
C3V02...	-	<b>Q25880036</b> <b>Q25880045</b>					<b>M50070001</b>	M70400001



## "30W" DC COILS

Type of protection (in relation to the connector used)	IP 65
Number of cycles	18.000/h
Supply tolerance	+10% / -10%
Ambient temperature	-54°C ÷ 60°C
Duty cycle	100% ED
Insulation class wire	H
Weight	0,2 Kg

### MOUNTING COMPATIBILITY

CRD04... CARTRIDGE CATALOGUE

VOLTAGE (V)	MAX. WINDING TEMPERATURE (AMBIENT TEMPERATURE 25°C)	RATED POWER (W)	RESISTANCE AT 20°C (OHM) ±10%
12V	108°C	30	4.7
24V	108°C	30	18.8

### ES MANUAL EMERGENCY

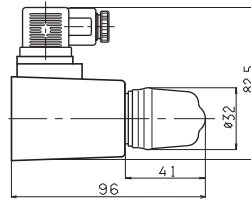

FLUSSO	FORZA AZIONAMENTO
2 → 1	10N
1 → 2	10+ (2,5 x P) N
P = PRESSIONE DI UTILIZZO (BAR)	

### P2 ROTARY EMERGENCY

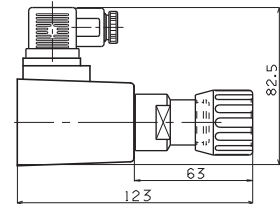

## SPARE PARTS

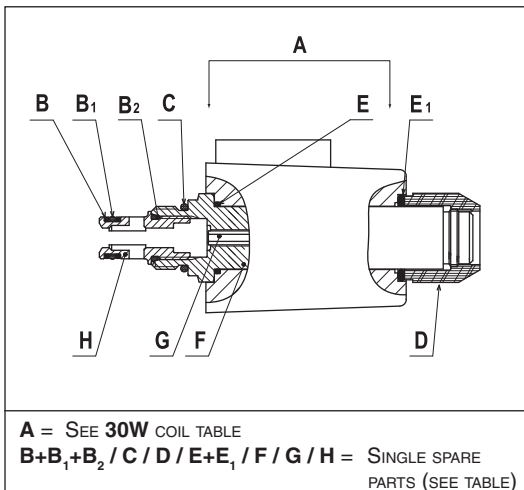

30W DC COIL	
12V	24V
M14100010 (L)	M14100011 (M)

COMPLETE KIT	CDL04
P2 ROTARY EMERGENCY	V89990007
ES MANUAL EMERGENCY	M19050001

	B	B <sub>1</sub>	B <sub>2</sub>	C	D	E	E <sub>1</sub>	F	G	H
	PARBAK	O RING	O RING							
VERS. A	Q25780026	Q25830015	Q25831017	Q25861010	M37050004	Q25830026	Q25830183	R83200997	M74360000	M70150004
VERS. B	Q25780030	Q25830021								M70150005

## UL RECOGNIZED COMPONENT MARK COILS



22 W COIL



27 W COIL

### UL RECOGNIZED COMPONENT MARK



The UL Recognized Component Mark may be used on component parts that are part of a larger product or system. The UL Mark is the most widely recognised and accepted evidence of product's compliance with Canadian and USA safety requirements.

### UL CATEGORY CODE (CCN)

- U.S.A.            **YSY12**  
- Canada           **YSY18**

UL category code number (CCN) is assigned in order to identify which product categories are covered by UL's Certification. Our category covers valve parts, such as solenoid operators, coil assemblies, coil enclosures, valve assemblies and similar items intended to be used as parts of electrically operated valves as indicated in the individual Recognitions.

### UL FILE NUMBER

**MH45162**

Visiting the UL web site ([www.ul.com](http://www.ul.com)), linking *certifications* and writing the correct UL File Number you can find our Certification.

The UL File Number is an alphanumeric designation assigned to any Company upon successful completion of a product evaluation or company certification.

"22 W" DC COILS	
IDENTIFICATION MARK	
1	Recognized Component Mark
2	<b>Type</b> Coil code, voltage and connector type <b>M14040021</b> 12 VDC (Hirschmann) <b>M14040022</b> 24 VDC (Hirschmann) <b>M14040031</b> 12 VDC (With flying leads) <b>M14040032</b> 24 VDC (With flying leads)
3	<b>21W@+ 50°C</b> Power at +50°C (ambient temperature) for 12 and 24V coils  <b>27W@- 25°C</b> Power at -25°C (ambient temperature) for 12 and 24V coils
4	<b>ED 100%</b> Duty cycle
5	<b>Tamb -25°C ÷ +50°C</b> Ambient operating temperature
6	<b>Class H</b> Insulation class wire

"27W" DC COILS	
IDENTIFICATION MARK	
1	Recognized Component Mark
2	<b>Type</b> Coil code, voltage and connector type <b>M14310011</b> 12 VDC (Hirschmann) <b>M14310012</b> 24 VDC (Hirschmann) <b>M14070021</b> 12 VDC (With flying leads) <b>M14070022</b> 24 VDC (With flying leads)
3	<b>22W@+ 50°C</b> Power at +50°C (ambient temperature) for 12V coils  <b>27W@+ 50°C</b> Power at +50°C (ambient temperature) for 24V coils  <b>32W@- 25°C</b> Power at -25°C (ambient temperature) for 12 and 24V coils
4	<b>ED 100%</b> Duty cycle
5	<b>Tamb -25°C ÷ +50°C</b> Ambient operating temperature
6	<b>Class H</b> Insulation class wire

The Underwriters Laboratories Inc.® is the accredited Unit to release the UL Mark, the most valued product safety symbol.

is the accredited Unit to release the UL Mark, the most valued



## "22W" DC COILS - UL RECOGNIZED

Type of protection (in relation to connector used)	IP 65
Number of cycle	18.000/h
Supply tolerance	-15% / +10%
Ambient temperature	-25°C ÷ 50°C
Power at +50°C (ambient temperature) for 12 and 24V coils	21W
Power at -25°C (ambient temperature) for 12 and 24V coils	27W
Duty cycle	100% ED
Insulation class wire	H
Weight	0,215 Kg

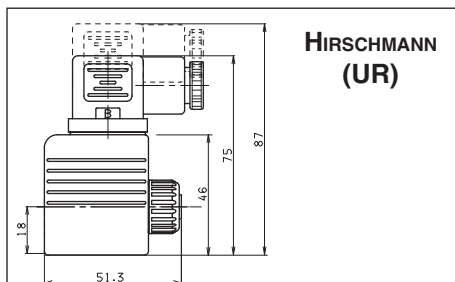

**HIRSCHMANN (UR)**

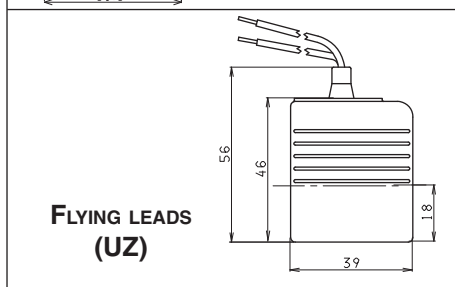

**FLYING LEADS (UZ)**

VOLTAGE (V)	MAX WINDING TEMPERATURE (AMBIENT TEMPERATURE 25°C)	RATED POWER (W)	RESISTANCE AT 20°C (OHM) ±10%
12V	116°C	22	6.30
24V	116°C	22	25.60

### VARIANT AND VOLTAGE CODES (WICH HAVE TO PUT IN THE ORDERING CODE VALVE)

<b>"22W" MOUNTING COMPATIBILITY</b>	CRP, CRD, C2V02 and C3V02 see Ch. V "Cartridge valves"
<b>VARIANT CODE</b>	<b>UR</b> = Hirschmann connection <b>UZ</b> = Solenoid with flying leads (500 mm) Other variants relate to a special design
<b>VOLTAGE CODE</b>	<b>L</b> = 12 VDC <b>M</b> = 24 VDC Voltage code is always stamped over on the coil



## "27W" DC COILS - UL RECOGNIZED

Type of protection (in relation to connector used)	IP 65
Number of cycle	18.000/h
Supply tolerance	-15% / +10%
Ambient temperature	-25°C ÷ 50°C
Power at +50°C (ambient temperature) for 12V coil	22W
Power at +50°C (ambient temperature) for 24V coil	27W
Power at -25°C (ambient temperature) for 12 and 24V coils	32W
Duty cycle	100% ED
Insulation class wire	H
Weight	0,215 Kg

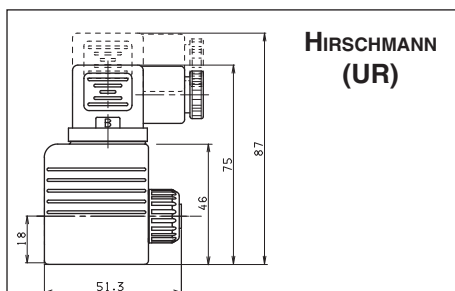

**HIRSCHMANN (UR)**

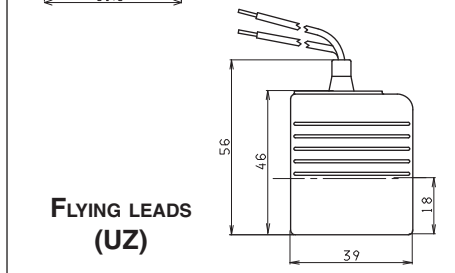

**FLYING LEADS (UZ)**

VOLTAGE (V)	MAX WINDING TEMPERATURE (AMBIENT TEMPERATURE 25°C)	RATED POWER (W)	RESISTANCE AT 20°C (OHM) ±7%
12V	123°C	27	5.30
24V	123°C	27	21.30

### VARIANT AND VOLTAGE CODES (WICH HAVE TO PUT IN THE ORDERING CODE VALVE)

<b>"27W" MOUNTING COMPATIBILITY</b>	AD2E... ADC3E... and CDL04... see Ch. I "Directional control" C3V03... see Ch. V "Cartridge valves" CDC3... see Ch. XI "Stackable valves"
<b>VARIANT CODE</b>	<b>UR</b> = Hirschmann connection <b>UZ</b> = Solenoid with flying leads (250 mm) Other variants relate to a special design
<b>VOLTAGE CODE</b>	<b>L</b> = 12 VDC <b>M</b> = 24 VDC Voltage code is always stamped over on the coil

12







**BREVINI<sup>®</sup>**

*Motion Systems*

Code DOC00078 - Rev. 05

**Dana Brevini S.p.A.**

Via Luciano Brevini 1/a

42124 Reggio Emilia

Tel. +39 0522 270711

Fax +39 0522 270660

[www.dana.com/brevini](http://www.dana.com/brevini)

[info@brevinifluidpower.com](mailto:info@brevinifluidpower.com)

