

PRESSURE REDUCING VALVES WITH RELIEVING - PILOT OPERATED

2

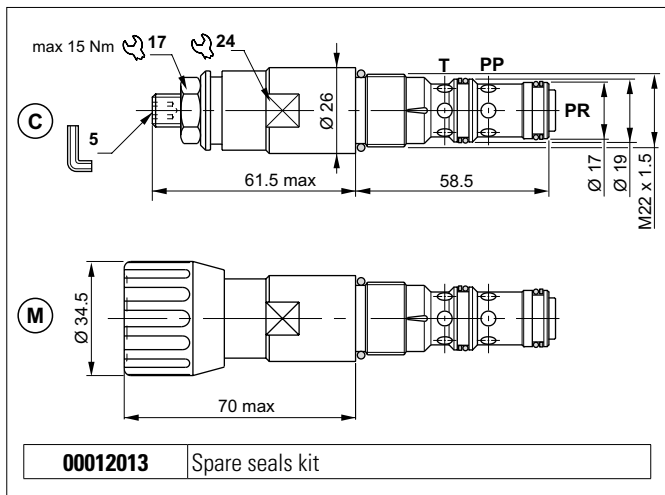

The pilot-operated pressure reducing valve feeds a secondary branch of a circuit at a lower pressure, guaranteeing minimum variation of the set pressure with flow alterations of up to 90 l/min.

Slight leakage is tolerated for this type of valve.

It raises the safety level with the RELIEVING system that enables fluid to pass through the valve from PR to T, preventing pressure increases in the controlled branch and protecting the load, and by making it impossible for plant operators to set a higher pressure rating than that specified in the catalogue. It has a pack spring with mechanical stop. It has a galvanised steel body. The plunger is in tempered and ground steel.

HYDRAULIC FEATURES

Max. pressure	350 bar
Setting range:	
Spring 1 (white)	max 60 bar
Spring 2 (yellow)	max 120 bar
Spring 3 (green)	max 250 bar
Maximum allowed Δp pressure between the inlet an outlet pressure	150 bar
Max. Flow	90 l/min
Max. draining on port T	0.5 ÷ 0.7 l/min
Hydraulic fluid	DIN 51524 Mineral oils
Fluid viscosity	10 ÷ 500 mm ² /s
Fluid temperature	-25°C ÷ 75°C
Ambient temperature	-25°C ÷ 60°C
Max. contamin. level class with filter	ISO 4406:1999 - class 19/17/14
Weight	0.25 kg
Tightening torque	30 ÷ 40 Nm
Cavity (M22 x 1.5)	CN047002 (See section 17)

HYDRAULIC SYMBOL

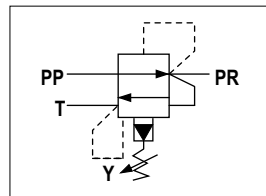

PRESSURE-FLOW OF RELIEVING

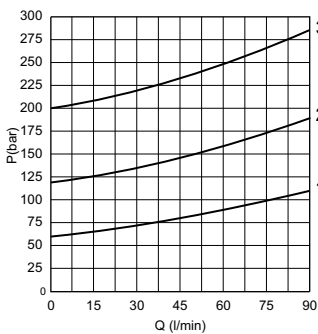

MIN. SETTING PRESSURE

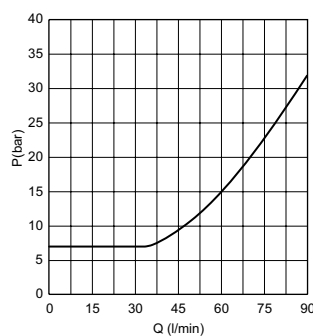

PRESSURE-FLOW RATE

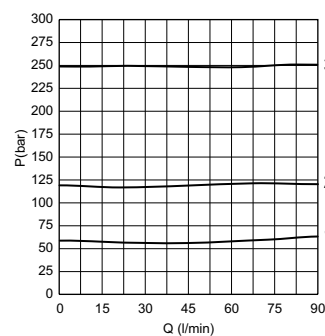

1 = CVR20.1..
2 = CVR20.2..
3 = CVR20.3..
Fluid used: mineral based oil with viscosity 46 mm²/s at 40°C.

The minimum permissible setting pressure depending on the spring: see curves.

ORDERING CODE

