

# AM.5.UD... MODULAR DIRECT CHECK VALVES CETOP 5

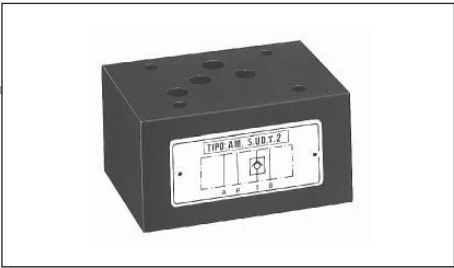

AM.5.UD...

SCREWS AND STUDS

CH. IV PAGE 36

AM5UD type modular check valves allow free flow in one direction, while a conical seated poppet prevents flow in the opposite direction.

They are available on single A, B, P and T lines, and on double A and B, P and T lines (see hydraulic symbols).

1 bar springs are standard, while 5 bar rated springs are available on request.

Max. operating pressure	350 bar
Minimum opening pressure spring 1	1 bar
Minimum opening pressure spring 5	5 bar
Max. flow	80 l/min
Hydraulic fluids	Mineral oils DIN 51524
Fluid viscosity	10 ÷ 500 mm <sup>2</sup> /s
Fluid temperature	-25°C ÷ 75°C
Ambient temperature	-25°C ÷ 60°C
Max. contamination level	class 10 in accordance with NAS 1638 with filter $\beta_{25} \geq 75$
Weight	2,1 Kg

4

### ORDERING CODE

- AM** Modular valve
- 5** CETOP 5/NG10
- UD** Direct check valve
- \*\*** Control on lines **A / B / P / T / AB / PT**
- \*** Minimum opening pressure  
1 = 1 bar  
5 = 5 bar
- \*\*** 00 = No variant  
V1 = Viton
- 2** Serial No.

### PRESSURE DROPS

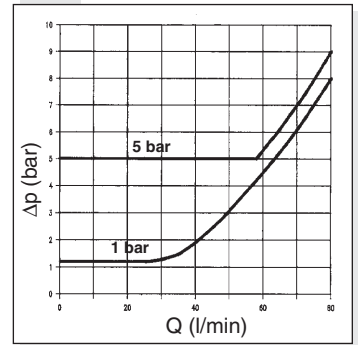

### OVERALL DIMENSIONS

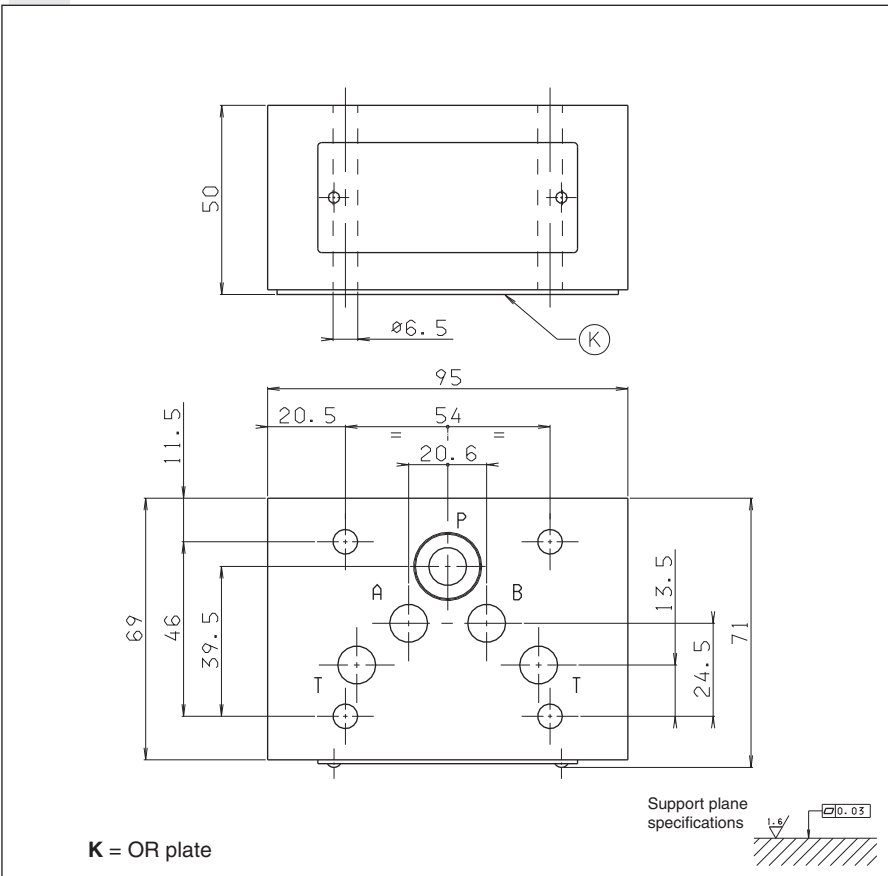

### HYDRAULIC SYMBOLS

