

SINGLE-PHASE MOTOR START VALVE - IN-LINE MOUNTING

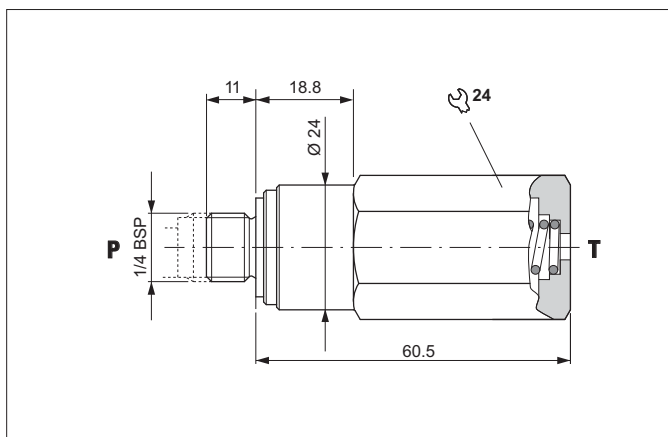

Valve used on power units to delay system pressurisation to allow a single-phase motor to reach the required speed.
 Fitted directly on the auxiliary pressure delivery line of unit 1 pumps or on the delivery branch between pump and unidirectional valve.
 The body is in steel and the tapered poppet in tempered and ground steel.

HYDRAULIC SYMBOL

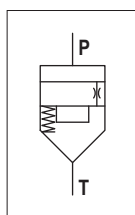

HYDRAULIC FEATURES

Max. working pressure	300 bar
Max. Flow	20 l/min
Min. working pressure	15 bar
Max operating frequency (with manual operated)	1 Hz
Working Temperature	-25°C ÷ 60°C
Hydraulic fluid	DIN 51524 Mineral oils
Fluid viscosity	10 ÷ 500 mm ² /s
Fluid temperature	-25°C ÷ 75°C
Max. contamin. level class with filter	ISO 4406:1999 - class 19/17/14
Weight	0.14 kg
Tightening torque	25 ÷ 30 Nm

ORDERING CODE

