

PRESSURE REDUCING VALVES WITH RELIEVING - DIRECT OPERATED

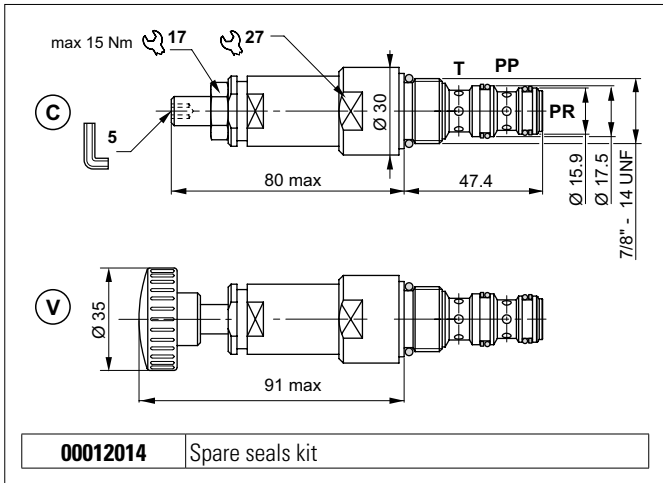

The direct acting pressure reducing valve feeds a secondary branch of a circuit at a lower pressure than the main branch, guaranteeing minimum variation of the set pressure with flow alterations of up to 20 l/min.

Slight leakage is tolerated for this type of valve.

It raises the safety level with the RELIEVING system that enables fluid to pass through the valve from PR to T, preventing pressure increases in the controlled branch and protecting the load, and by making it impossible for plant operators to set a higher pressure rating than that specified in the catalogue. It has a pack spring with mechanical stop.

It has a galvanised steel body. The plunger is in tempered and ground steel.

HYDRAULIC FEATURES

Max. pressure	320 bar
Setting range:	
Spring 1 (white)	max 2 ÷ 30 bar
Spring 2 (yellow)	max 6 ÷ 70 bar
Spring 3 (green)	max 35 ÷ 130 bar
Spring 4 (blue)	max 65 ÷ 230 bar
Max. Flow	20 l/min
Max. draining on port T	0.2 l/min
Hydraulic fluid	DIN 51524 Mineral oils
Fluid viscosity	10 ÷ 500 mm ² /s
Fluid temperature	-25°C ÷ 75°C
Ambient temperature	-25°C ÷ 60°C
Max. contamin. level class with filter	ISO 4406:1999 - class 19/17/14
Weight	0.3 kg
Tightening torque	35 ÷ 40 Nm
Cavity (7/8 - 14 UNF)	CD019006 (See section 17)

HYDRAULIC SYMBOL

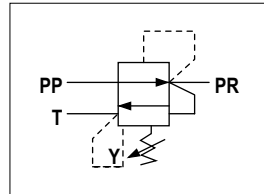

PRESSURE-FLOW OF RELIEVING

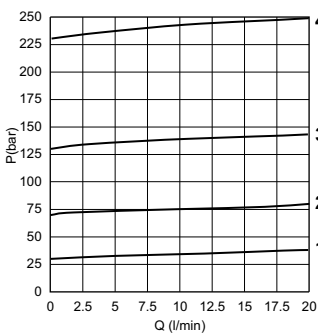

MIN.SETTING PRESSURE

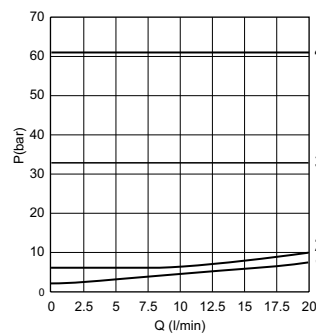

PRESSURE-FLOW RATE

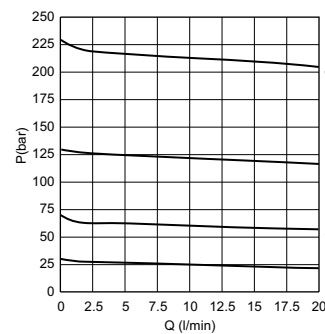

- 1 = CVR06.1..
- 2 = CVR06.2..
- 3 = CVR06.3..
- 4 = CVR06.4..

Fluid used: mineral based oil with viscosity 46 mm²/s at 40°C.

ORDERING CODE

